

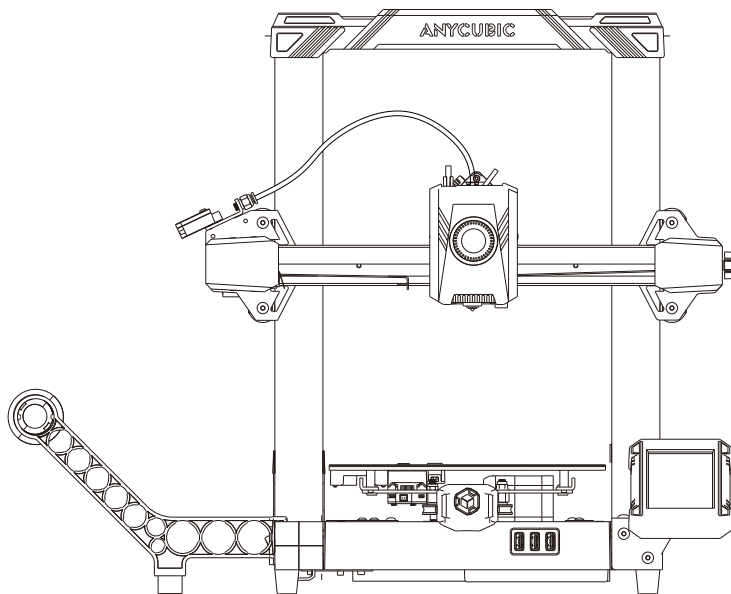

Anycubic Kobra 2 Pro

User Manual



The product picture is for reference only. Please refer to the actual product.

Dear customer,

Thank you for choosing **ANYCUBIC** products.

Maybe you are familiar with 3D printing technology or have purchased **ANYCUBIC** printers before, but we still highly recommend that you read this manual carefully. The installation techniques and precautions in this manual can help you avoid any unnecessary damage or frustration.

Please visit <https://support.anycubic.com/> to contact us if you have any question. You can also gain more information such as software, videos, models from the website.



ANYCUBIC APP



Help center



ANYCUBIC Support Center

Team **ANYCUBIC**

Copyrighted by "Shenzhen Anycubic Technology Co., Ltd ", all rights reserved.

Product Overview

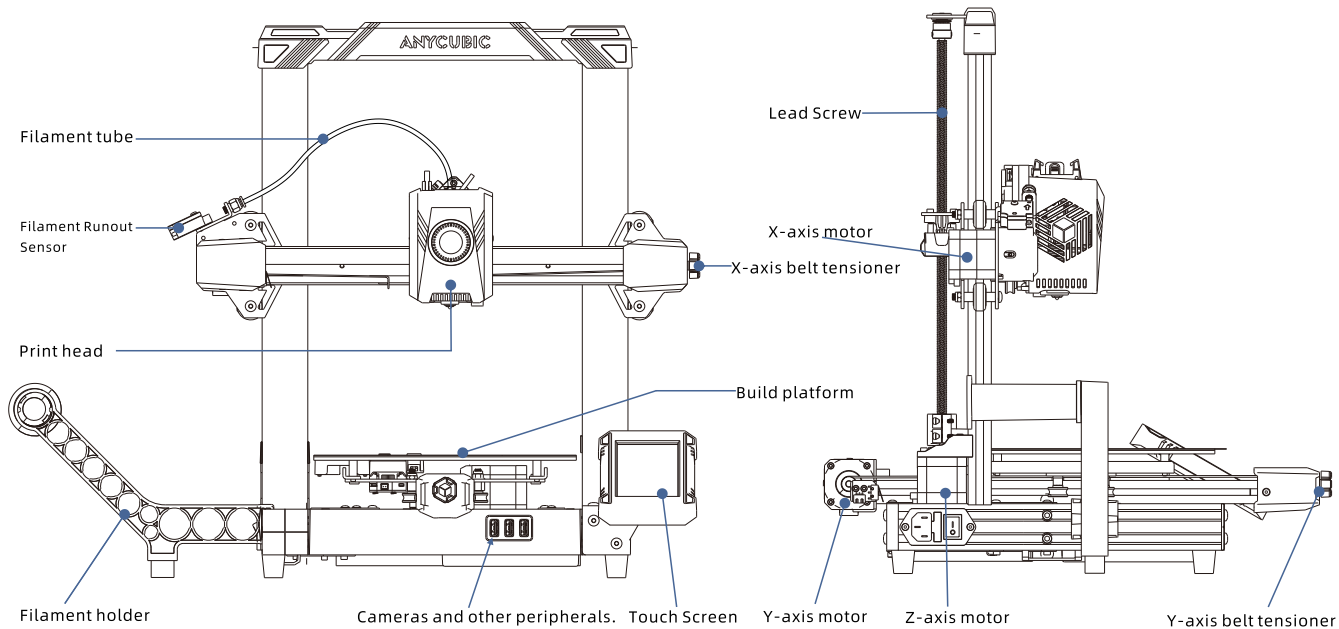

Packing List

The following pictures are for reference only. Please refer to the actual object.

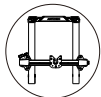

1



2



3



4



5

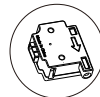

6

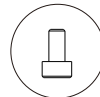

M3*6
(4pcs)



M5*6
(2pcs)



M5*14
(1pcs)

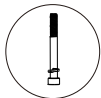

M5*45
(4pcs)



U-DISK
(1pcs)



Spare nozzle
(1pcs)



Power cord
(1pcs)



Cable fixing clip
(3pcs)



Wrench
(1 set)



4.0/3.0/2.5/2.0/1.5



Nozzle Cleaner



Filament



Grease

Technical Specification

Printing

Technology:FDM (Fused Deposition Modeling)

Build Size:220 mm (L) × 220 mm (W) × 250mm (H)

Layer Thickness:0.05 - 0.3 mm

Positioning Accuracy:X / Y / Z 0.0125 / 0.0125 / 0.0025 mm

Extruder Quantity:Single

Nozzle Diameter:0.4 mm

Supported Materials:PLA/TPU/PETG/ABS etc

Temperature

Ambient Operating Temperature:8 °C - 40 °C

Operational Extruder Temperature:Max 260 °C

Operational Print Bed Temperature :Max 110 °C

Software

Slicing Software:AnycubicSlicer/PrusaSlicer/Cura

Software Input Formats: .STL/.OBJ

Software Output Formats:GCode

Connectivity:U-DISK,AC Cloud

Electrical

Power Input:110 V / 220 V AC, 50 / 60 Hz

Rated Power:400 W

Physical Dimensions

Printer Dimensions:463mm (L) × 435 mm (W) × 486 mm (H)

Net Weight:~8.4 kg

Machine Installation

01 Install frame

Pull the belt above to raise the X-axis.

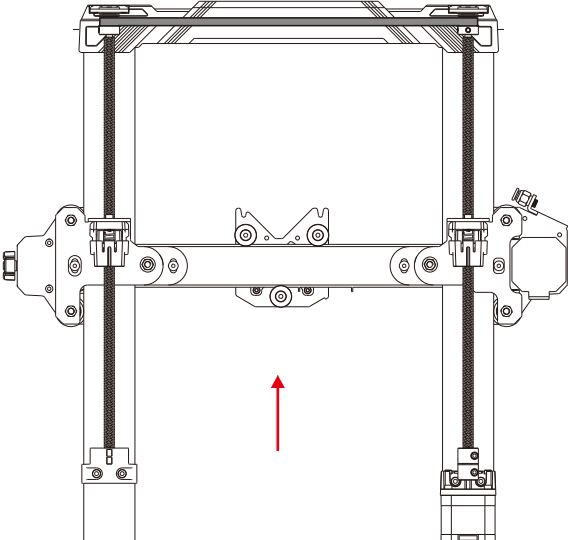
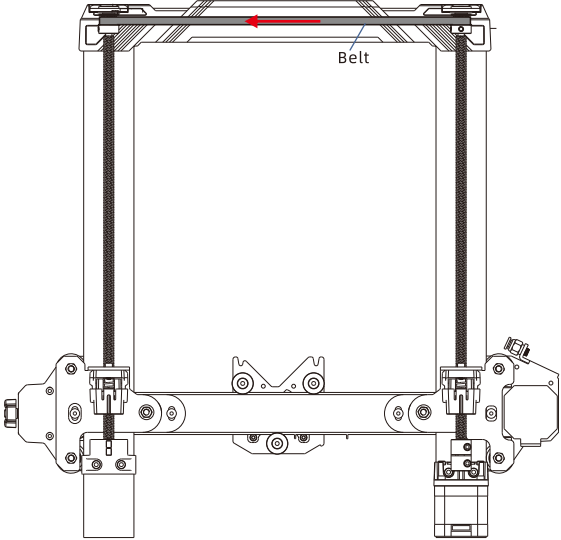

01 Install frame

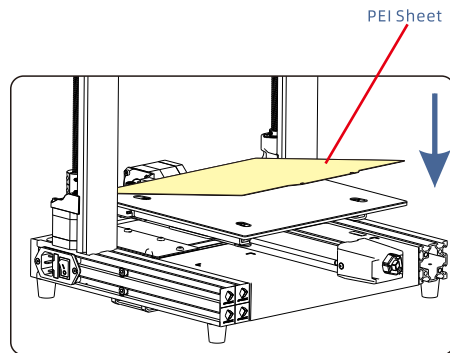
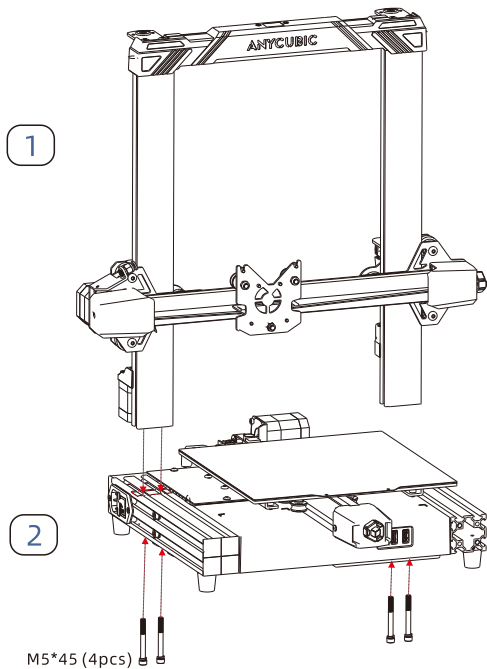
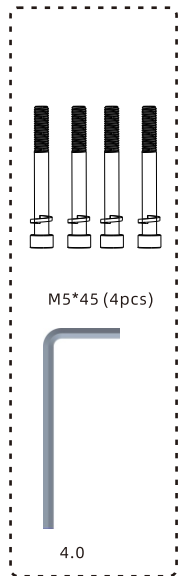

Note: Please install PEI sheet.

02 Install print head

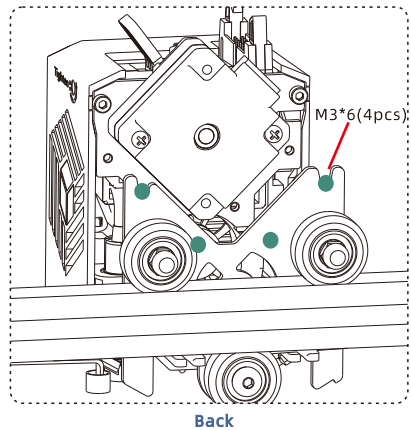
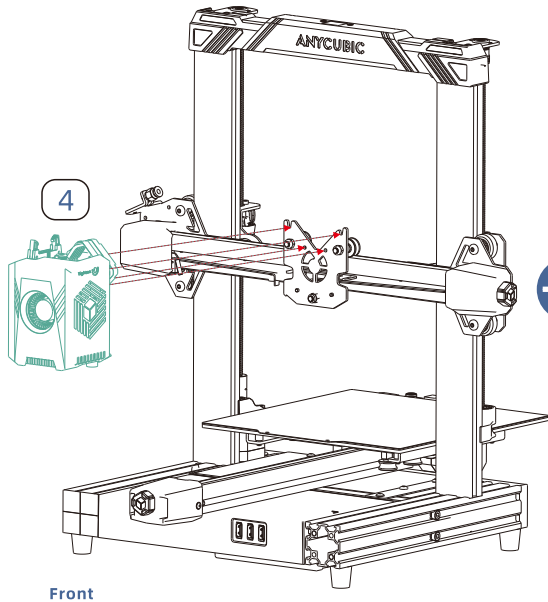
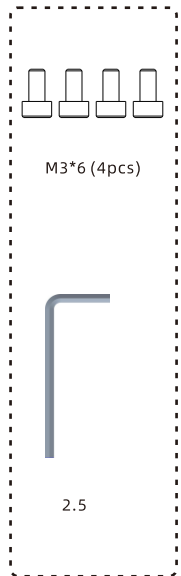

03 Install screen



M5*6 (2pcs)



M5*14 (1pcs)



3.0

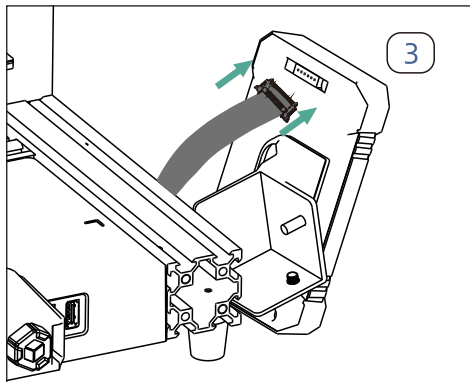

Insert the FPC into the port by pressing the terminal as pictured.

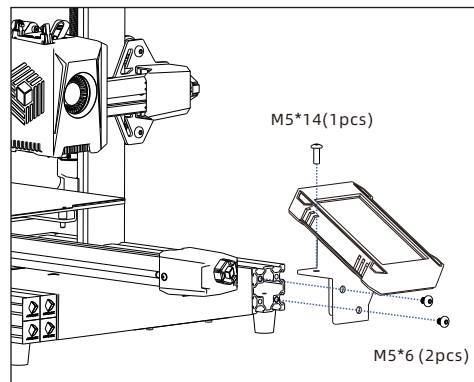

Secure the screen using screws.

04 Install filament runout sensor

Step 1: Use screws to secure the filament runout detection in the position indicated in the diagram.

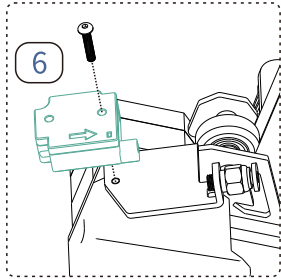

2.0

Filament Tube

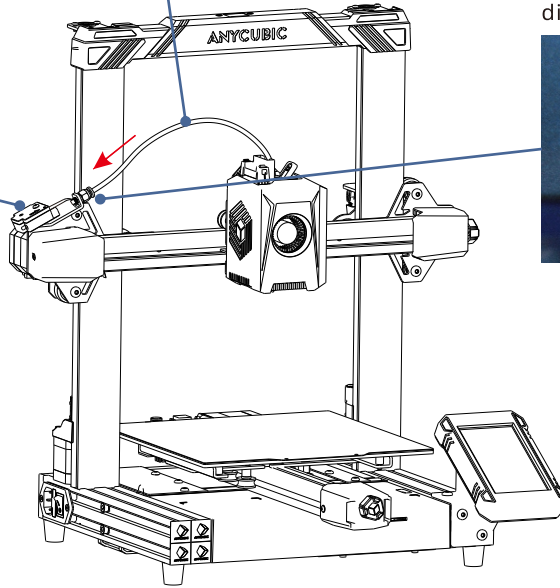

Step 2: Insert the filament tube in the direction indicated in the diagram.

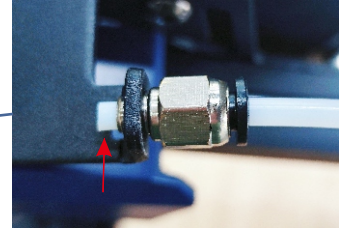

05 Install filament holder

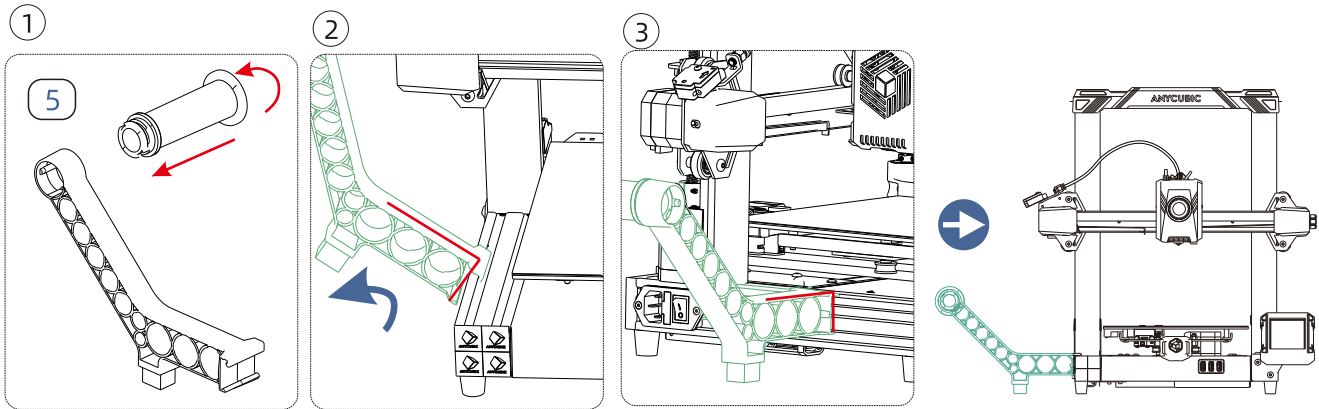

06 Wiring

① Filament runout sensor

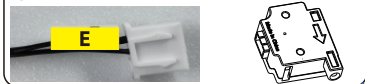

② X-axis motor



③ X-axis limit switch



④

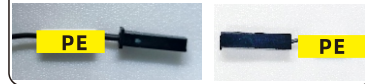

⑤ Z-axis motor



⑥ E-axis motor



⑦ Print head

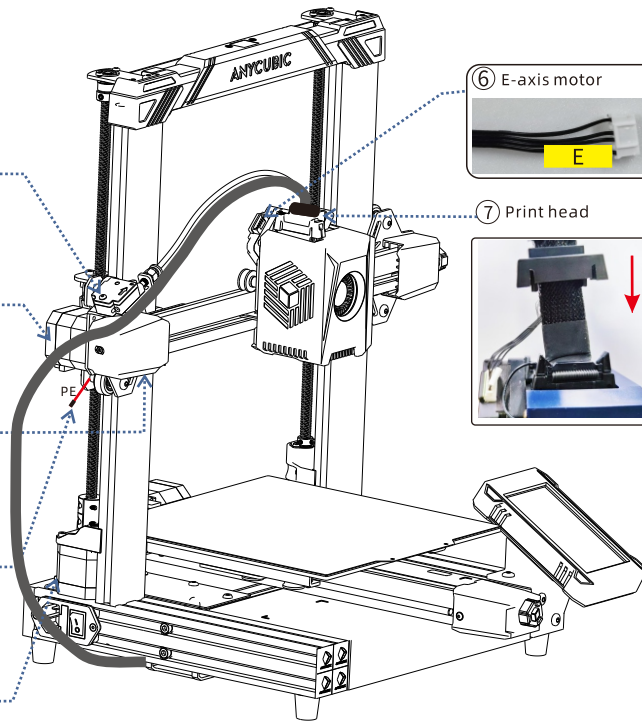
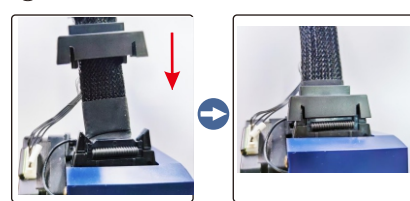

06 Wiring

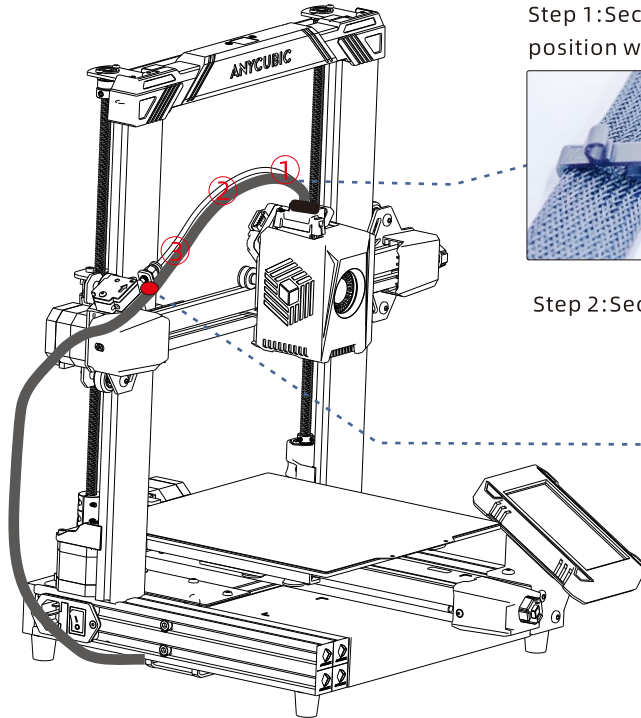

Step 1: Secure the cables and filament tube at the indicated position with a retaining clamp.

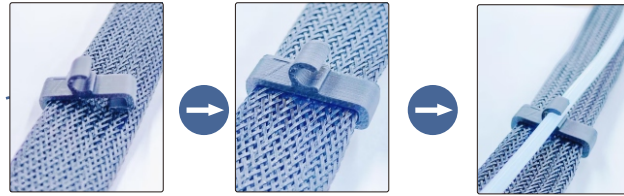

Step 2: Secure the cables at the indicated position using zip ties.

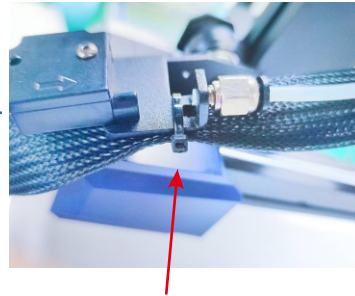

Check Before Use

1. Pulley elastic adjustment

Check if the print head is shaking. If it is, adjust the hexagonal isolation column located underneath the print head until it slides smoothly and without shaking.

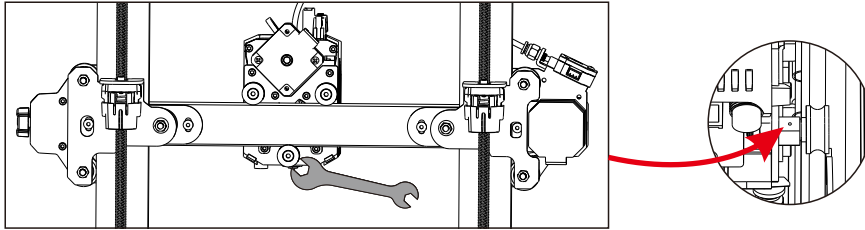

Print head

Check if the print bed is shaking. If it is, adjust the hexagonal isolation column located underneath the print bed until it slides smoothly and without shaking.

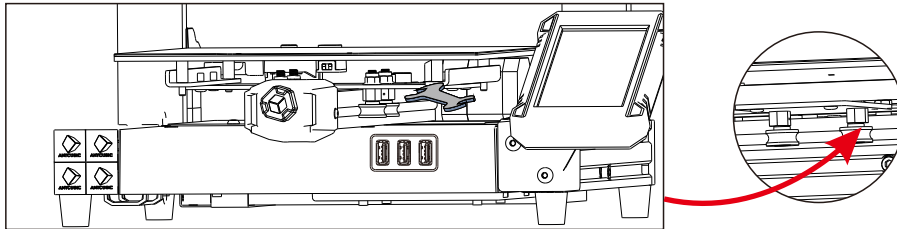

Platform

Similarly, the pulleys on both sides of the gantry frame can also be adjusted.



2. Belts

Please manually move the print head and print platform. If there is any difficulty or abnormal noise during the movement, adjust the tensioner to ensure smooth sliding of the print head or platform.

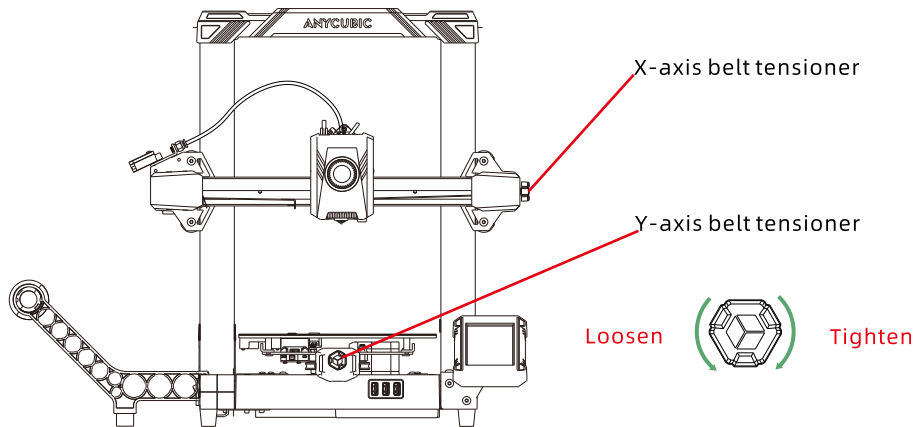

3. Connecting to Power

Connect the printer to a power outlet with the power cable, then power on the printer.

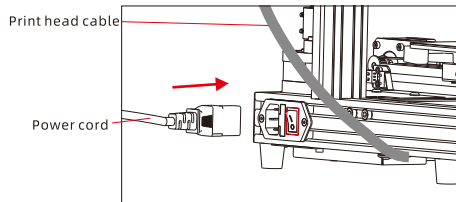

Note: When inserting the power cord, please avoid crossing it with the print head cable to prevent interference.



Power-on guide

① Language



② Area

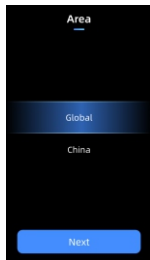

③ Network

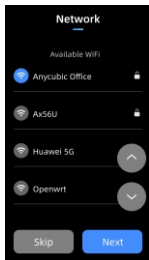

④ Cloud

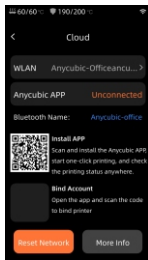

⑤ Complete setup

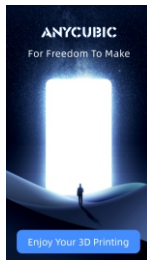

⑥ Start Operation Guide



⑦ Insert U-Disk



⑧ Self Test

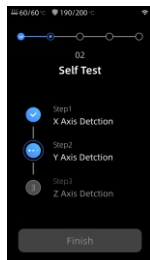

⑨ Auto-Level

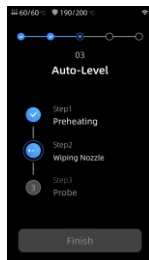

⑩ Load Filament



⑪ Vibration compensation ⑫ Print The Model

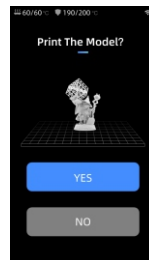

Note: The current interface is for reference only. Due to ongoing feature upgrades, please refer to the UI of the latest firmware release for accurate information.



Leveling

Press "Tools" - "Control" - "Auto Level". Wait for the machine to complete the leveling process.

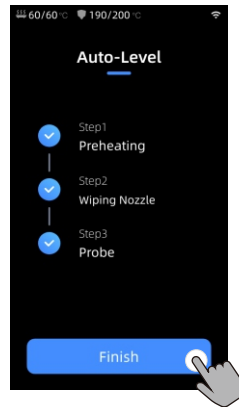
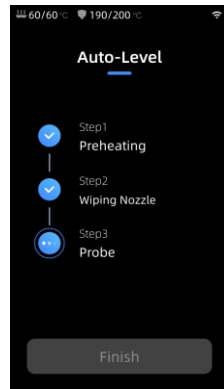
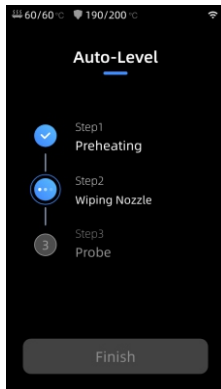
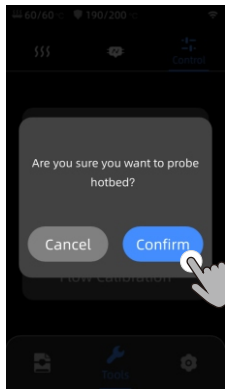
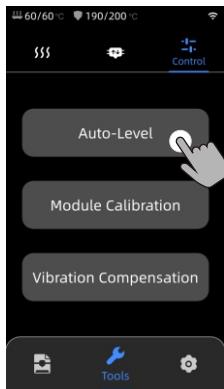

Note:

- 1) Please check whether the PEI board is installed before leveling.
- 2) The leveling sensor is only used for platforms with metal surfaces. If you replace the printing platform by yourself, please choose a platform with a metal surface to ensure the normal use of the automatic leveling function.



Loading Filament

1. Put the filament onto the spool holder.
2. Insert the filament into the extruder until you feel some resistance. While doing so, press and hold the button on top of the extruder.
3. Press "Tools" - "Filament" - "PLA/ABS". Wait for the nozzle to heat up to the preset temperature. Press "Extrude" and wait for the filament material to be extruded from the nozzle. After stopping the filament feed, please clean the nozzle.

Note: Before inserting the filament into the extruder, make sure to straighten the end of the filament.

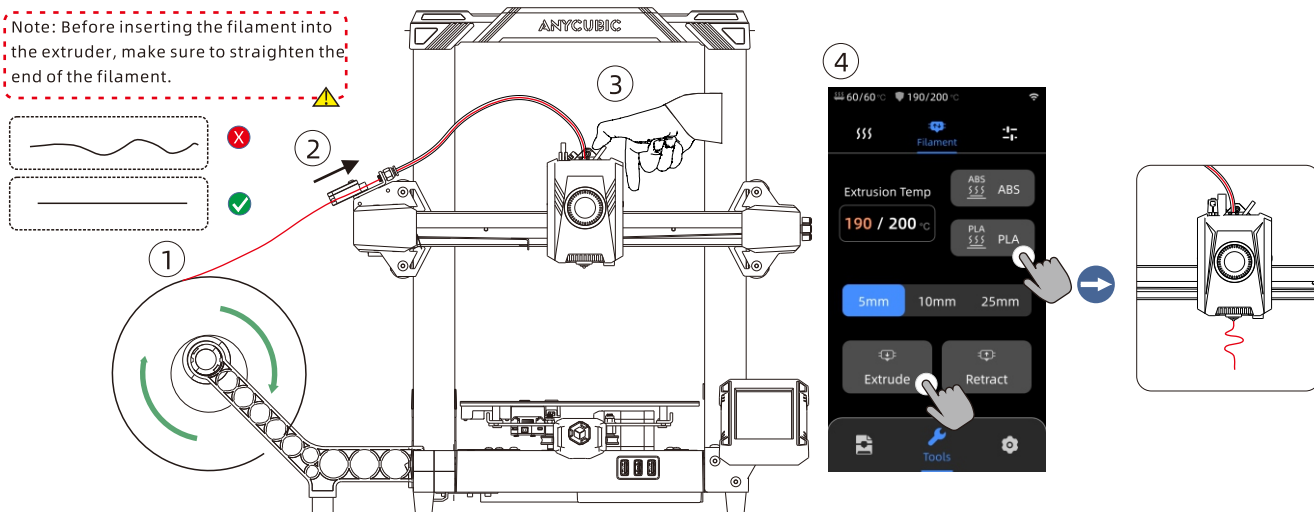

First print

1) Select a model from the local or U-DISK and start printing.

*We recommend using one of the pre-loaded files as a first test print.

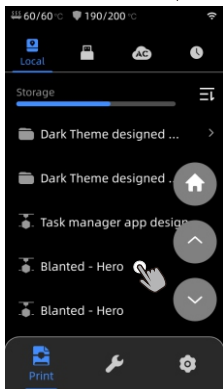
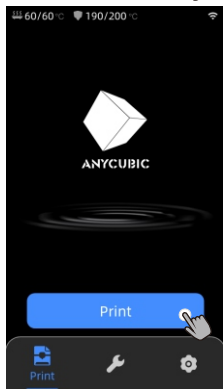

Select the model from local storage or U-DISK.

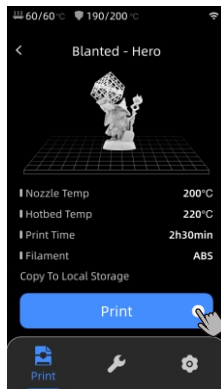

Press "Print".

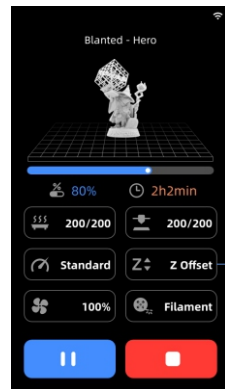

Printing in progress.

Note: After starting the printing process, please observe the situation of the first layer. If situations ① and ③ occur on the first layer, it indicates that the Z-Offset value is not matching. You can adjust the Z-Offset value during the printing process to adjust the distance between the print head and the print platform. ⚠

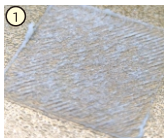

(too low)

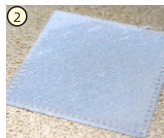

(perfect)



(too high)

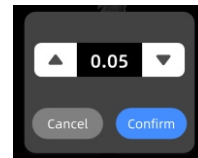
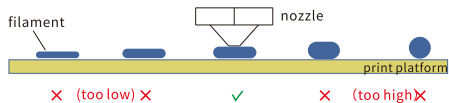

Other Function Descriptions

Vibration Compensation: To achieve better printing results, it is recommended to perform a vibration compensation check after printing for more than 300 hours or when the machine has been moved. This feature helps reduce the occurrence of banding during high-speed printing. Regular vibration compensation checks help maintain the stability and accuracy of the printer, thereby improving print quality.

Press "Tools" - "Control" - "Vibration compensation" and wait for the machine to complete the calibration. Please do not touch the machine during the calibration process.

Filament Runout Detection: This function is designed to prevent printing failures when the filament runs out during the middle of a print. It alerts the user to replace the filament before continuing the print, effectively preventing wasted prints due to filament shortage.

Note:After filament runout, you will need to remove the remaining filament from the filament tube and then insert a new filament.

Retraction Instructions: Press "Tools" - "Filament" - "PLA/ABS". Wait for the nozzle to heat up to the preset temperature. Press "Retract" and wait for the filament material to retract, or manually pull out the filament directly by pressing the button above the extruder.

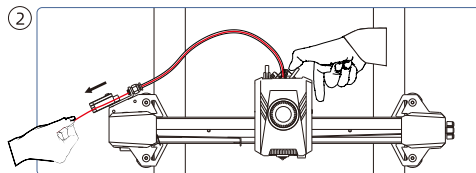
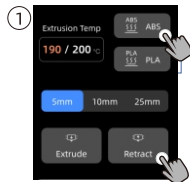

Maintenance Recommendation

Z-axis Lead Screws

*The Z-axis lead screw needs regular lubrication, as proper lubrication ensures smooth movement. It is recommended to perform maintenance every three months.

Before applying lubricating grease to the Z-axis lead screws, it is important to clean them thoroughly, removing any dust or plastic particles. Then, using the axis movement controls, move the print head to a higher position. Apply a thin coat of lubricating grease on the Z-axis lead screws, and then home the printer again. You can repeat this movement process a few times to ensure the grease is evenly distributed over the Z-axis lead screws. Once completed, clean off any excess lubricating grease that may have accumulated near the leadscrew nuts.

X/Y-axis double metal spindles

*The X/Y-axis double metal spindles require regular lubrication, as proper lubrication ensures smooth movement. It is recommended to perform maintenance once a month.

Before applying lubricating grease to the X/Y-axis double metal spindles, it is important to clean them thoroughly, removing any dust or plastic particles. Then, apply a thin coat of lubricating grease on the X/Y-axis double metal spindles and home the printer. You can repeat the movement process a few times to ensure the grease is evenly spread over the X/Y-axis double metal spindles.

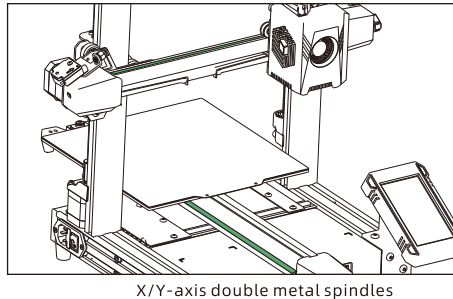
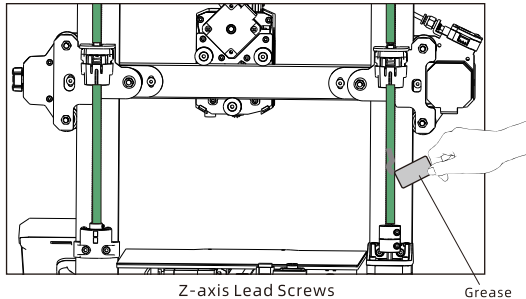

*Please scan the QR code for more maintenance information.

Troubleshooting Guide

If there is a leveling anomaly, please follow the steps below to check:

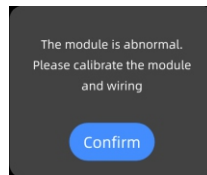

1) After powering off, check the wiring of the leveling calibration module to ensure it is connected properly. Then, restart the machine.

2) Press [Tools]-[Control]-[Module Calibration]-[Position Calibration]. Use the [X Move] and [Y Move] options on the screen to move the nozzle to the center point of the calibration module. Once done, click on [Save]. Afterward, perform the leveling operation again.

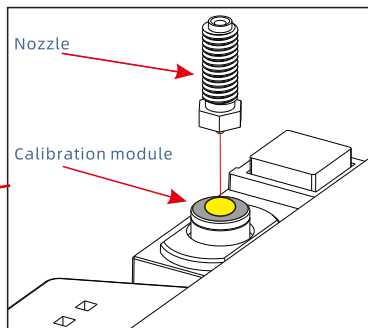
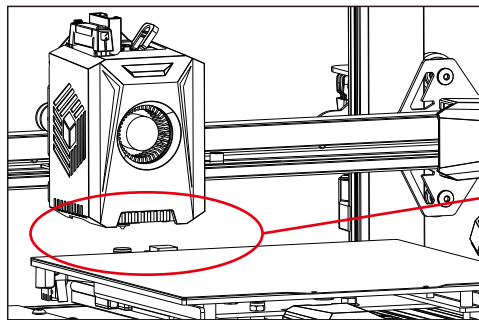

The shown nozzle is on the print head and some parts are left out for better display.

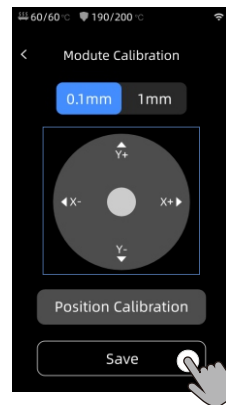

Troubleshooting Guide

X/Y/Z axis motor not moving or making abnormal noise:

- ① Check if the motor wires are loose and recheck the connections.
- ② The corresponding limit switch may not be triggering properly. Check if there is any interference with the axis movement and ensure that the limit switch wires are secure.

Extruder abnormal extrusion:

- ① Check if the extruder motor wire is loose.
- ② Ensure that the extruder gear is securely tightened to the motor shaft.
- ③ The print head may not be getting sufficient cooling. Make sure that the print head cooling fan is functioning properly.
- ④ There may be a clog at the nozzle. Try briefly heating the nozzle to 230°C and manually extruding the filament with force to clear the clog. Alternatively, use a fine needle to clear the nozzle while it is preheated.

Model not sticking to the platform or warping:

- ① The key to model adhesion to the platform is whether the filament attaches to the platform during the first layer. If the distance between the nozzle and the platform exceeds 0.2mm during the first layer, adhesion to the platform will be significantly reduced, requiring releveling.
- ② When slicing the model, set the print platform adhesion to "Brim," which helps enhance adhesion and prevent warping issues.

Model misalignment:

- ① The movement speed or print speed may be too fast. Try reducing the speed.
- ② The X/Y axis belts may be too loose, or the timing pulleys may not be securely fixed.

Excessive stringing:

- ① Insufficient retraction distance. Increase the retraction distance in the slicing software.
- ② Slow retraction speed. Increase the retraction speed in the slicing software.
- ③ Enable Z-lift during retraction in the slicing software, with a lift height of approximately 0.25mm.
- ④ The printing temperature may be too high, causing the filament to be excessively viscous. Lower the printing temperature slightly.



*The questions that are not covered above, please scan the QR code to obtain the information.

Attention

1. Anycubic 3D printer generates high temperature. DO NOT reach inside of the printer during operation. Contact with extruded materials may cause burns.
2. Use high temperature resistant gloves when operating the product.
3. This equipment is not suitable for use in locations where children are likely to be present.
4. The fuse rating for the printer is 250V 10A. Never replace the fuse with one of a higher amperage, otherwise it may cause fire.
5. The socket-outlet shall be easily accessible.

If the above problems cannot be solved, please initiate consultation in our after-sales service system, and our engineers will reply you in the form of email within one working day.

(<https://support.anycubic.com/>)



Warm tips:

1. Fill in the information based on the SN of the corresponding model. The items with red dots are mandatory.
2. If the order is successful, you will soon receive a reply from the after-sales service system in your mailbox.
3. If you successfully place an order but do not receive an email, please watch out for spam.
4. If the order creation fails, please pay attention to the pop-up reminder on the web page.



Name: Apex CE Specialists GmbH
Add: Habichtweg 1 41468 Neuss Germany
Contact: Wells Yan
Tel: +353212066339
E-Mail:Info@apex-ce.com



Name: APEX CE SPECIALISTS LIMITED
Add: 89 Princess Street,Manchester, M1 4HT,UK
Contact: Wells
Tel: + 441616371080
E-Mail:info@apex-ce.com



M02030357