

BIXOLON®

User's Manual
XD5-40t Series

THERMAL TRANSFER LABEL PRINTER
Ver. 1.00



<http://www.bixolon.com>

Introduction

XD5-40t series printers have been designed to be connected to various types of electronic devices such as computer peripheral devices.

※ The main features of the printer are as follows

1. XD5-40t : Maximum 152mm/s(Max 6ips) printing speed
XD5-43t : Maximum 102mm/s(Max 4ips) printing speed
2. 4inch THERMAL TRANSFER LABEL PRINTER
3. 211 x 285 x 188 (W x D x H)
4. Support for multiple interfaces
 - Standard(Wire): USB & USB HOST
 - Option(Wire): USB & USB HOST & Serial & Ethernet
 - Option(Wireless): Bluetooth, WLAN
5. Easy media loading
6. Can print a range of barcodes
7. Option : Peeler, Auto Cutter
8. Option : LCD

It is advisable to read the contents of this manual carefully before using the printer for the first time.

※ Use only authorized supplies that can be trusted!

- We are not responsible for quality and service for damage caused by the use of unauthorized products (or recycled ones).

Safety Information

 **Warning:** Warnings must be heeded carefully in order to prevent serious physical harm.

 **Caution:** Cautions must be heeded in order to prevent minor injuries, equipment damage, or data loss.

Symbol Information

	DC (Direct current)
	Warning, Caution
	USB
	Ethernet

Table of Contents

1. Content Confirmation	9
2. Product Part Names	10
3. Installation & Usage	12
3-1 Printer Installation Placings	12
3-2 Power Connection	13
3-3 Interface	15
3-3-1 Standard Interface (USB & USB HOST)	16
3-3-2 Optional Interface (USB & USB HOST & Serial & Ethernet)	17
3-4 Media Installation	18
3-5 Ribbon Installation	20
3-5-1 Type of Ribbon	20
3-5-2 Inserting a 1 Inch Core Ribbon	21
3-5-3 Inserting a 0.5 Inch Core Ribbon	21
3-5-4 Knob Adjust Method According to Ribbon Type	22
3-5-5 Narrow Ribbon Installation	23
3-5-6 Ribbon Removal	23
3-5-7 Ribbon Sensor Activation	23
3-6 How to Use the Ribbon Guide	24
3-7 Button & LED (Standard Model)	25
3-7-1 Button Operations	25
3-7-2 LED Indicator For Various Printer Statuses	26
3-8 Button & LCD (LCD Model)	27
3-8-1 Button Operation	27
3-8-2 Interface Status Icon	28
3-8-3 Menu Composition	29
3-8-4 Setting Menu Explanation	32
3-8-5 Interface Menu Explanation	36
3-8-6 Sensor Menu Explanation	41
3-8-7 Tools Menu Explanation	41
3-8-8 Information Menu Explanation	47
4. Self-test	48
5. Detailed Features	49
5-1 Stand-alone Configuration Mode	49
5-1-1 Start Stand-alone Configuration Mode and execute each function	49
5-1-2 Function List Of Stand-alone Configuration Mode	49
5-2 Pause/Cancel	50
5-2-1 Pause/Resume Function	50
5-2-2 Print Cancellation	51
5-3 Smart Media Detection	52
5-4 Gap Sensor Auto Calibration Mode	52
5-5 B/M Sensor Auto Calibration Mode	53
5-6 Media Sensor Manual-Calibration	54
5-7 Data Dump Mode	55
5-8 Factory Reset	55
5-9 Print Standby Mode	56
5-9-1 About Print Standby Mode	56

XD5-40t Series

5-9-2 How to switch the printer from Standby Mode to Print Ready Mode	56
5-10 Media Installation Method of Peeler (Option) Model	57
5-11 Using Fan-Fold or External Media	59
5-11-1 When using Fan-Fold media	60
5-11-2 When using Large media roll (Optional)	61
5-12 Auto Cutter (Optional).....	62
6. Printer Maintenance	63
6-1 Cleaning Printer Head	63
6-2 Cleaning Sensors, Roller or/and media Path	64
6-3 Replacing Roller	65
7. Appendix	66
7-1 Specifications	66
7-2 Label Types	66

Manual Information

This user's guide contains basic information for product usage as well as for emergency measures that may be required.

※ The following separate manuals provide more detailed content on various technological issues and areas.

1. Windows Driver Manual

This manual provides information on the installation instructions and main functions of the windows driver.

2. Unified Label Utility-II Manual

This manual provides information on the usage of software for function selection of this product, operating condition modification, etc.

3. Programming(SLCS) Manual

This manual provides information on label printer commands.

4. True Font Downloader Manual

This manual provides information on the usage of the font downloader that can download true type fonts and facilitate their usage as device fonts.

5. Network Connection Manual

This manual provides information on the configuration and usage of network interface.

6. Bluetooth Connection Manual

This manual provides information on connection instructions the Bluetooth interface.

7. Label Design Program Manual

This manual provides information on the usage of the Windows PC program that can make labels by adding text, graphics, or barcodes at desired positions.

Safety Precautions

In using the present appliance, please keep the following safety regulations in order to prevent any hazard or material damage.



WARNING

Warnings must be heeded carefully in order to prevent serious physical harm.

Do not plug several products in one multi-outlet.

- This can provoke over-heating and a fire.
- If the plug is wet or dirty, dry or wipe it before usage.
- If the plug does not fit perfectly with the outlet, do not plug in.
- Be sure to use only standardized multi-outlets.

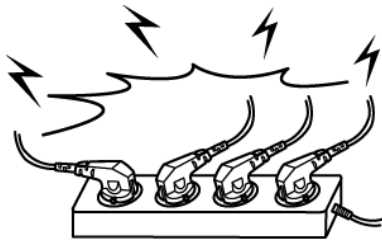

You must use only the supplied adapter.

- It is dangerous to use other adapters.



Do not pull the cable to unplug.

- This can damage the cable, which is the origin of a fire or a breakdown of the printer.

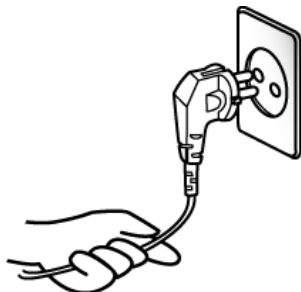

Keep the plastic bag out of children's reach.

- If not, a child may put the bag on his head.



Do not plug in or unplug with your hands wet.

- You can be electrocuted.



Do not bend the cable by force or leave it under any heavy object.

- A damaged cable can cause a fire.

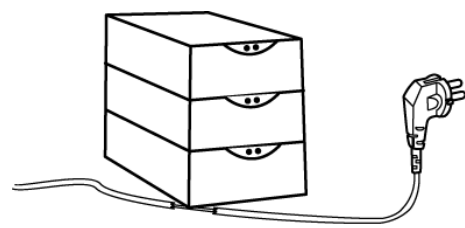



CAUTION

Cautions must be heeded in order to prevent minor injuries, equipment damage, or data loss.

If you observe a strange smoke, odor or noise from the printer, unplug it before taking following measures.

- Switch off the printer and unplug the set from the mains.
- After the disappearance of the smoke, call your dealer to repair it.

TO UNPLUG



Keep the desiccant out of children's reach.

- If not, they may eat it.

PROHIBIT



Install the printer on the stable surface.

- If the printer falls down, it can be broken and you can hurt yourself.

PROHIBIT

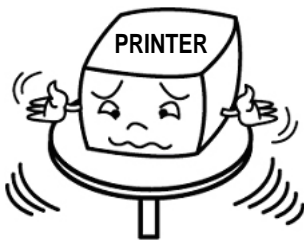

Use only approved accessories and do not try to disassemble, repair or remodel it for yourself.

- Call your dealer when you need these services.
- Do not touch the blade of auto cutter.

DISASSEMBLING PROHIBITED

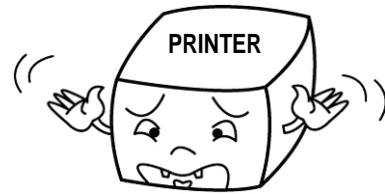

Do not let water or other foreign objects in the printer.

- If this happened, switch off and unplug the printer before calling your dealer.

PROHIBIT



Do not use the printer when it is out of order. This can cause a fire or an electrocution.

- Switch off and unplug the printer before calling your dealer.

TO UNPLUG



1. Content Confirmation

The following items should all be contained in the printer package.
Contact the dealer from which the purchase was made if any item is damaged or missing.

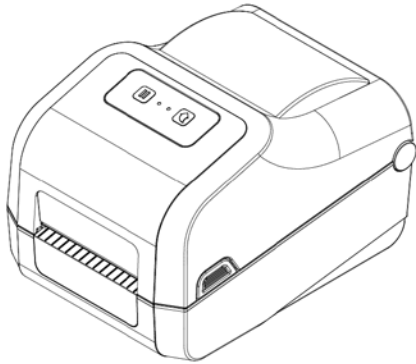

XD5-40t/43t



XD5-40t/43t LCD Model(Optional)

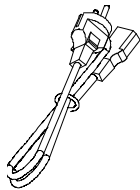

Power Cord

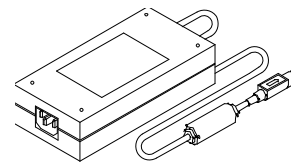

AC/DC Adapter

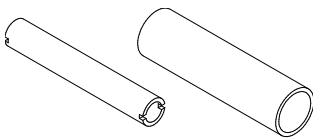

Core(0.5 inch, 1 inch)

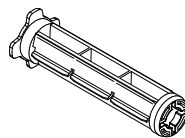

Holder Ribbon(2ea)



Quick Manual



USB Cable

※ **Optional**



Serial(RS-232C) Cable

2. Product Part Names

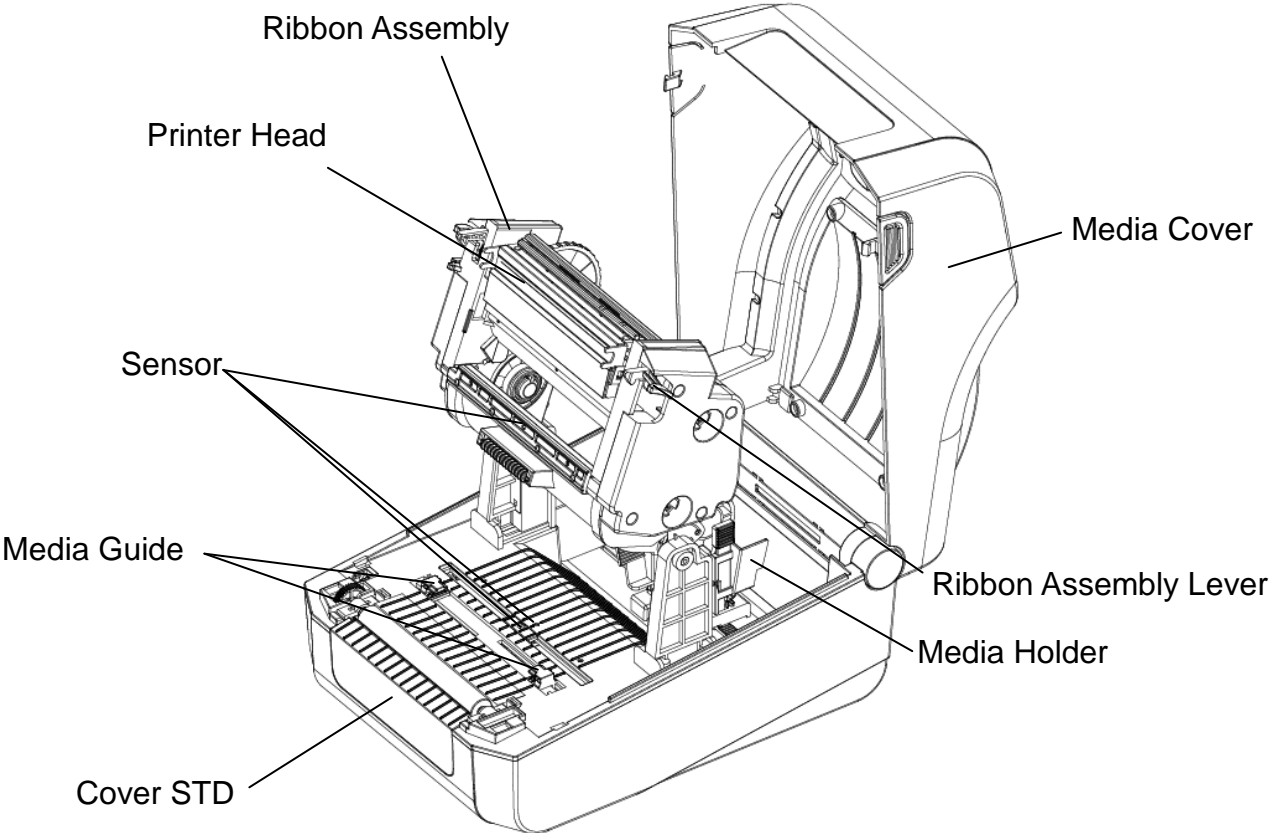
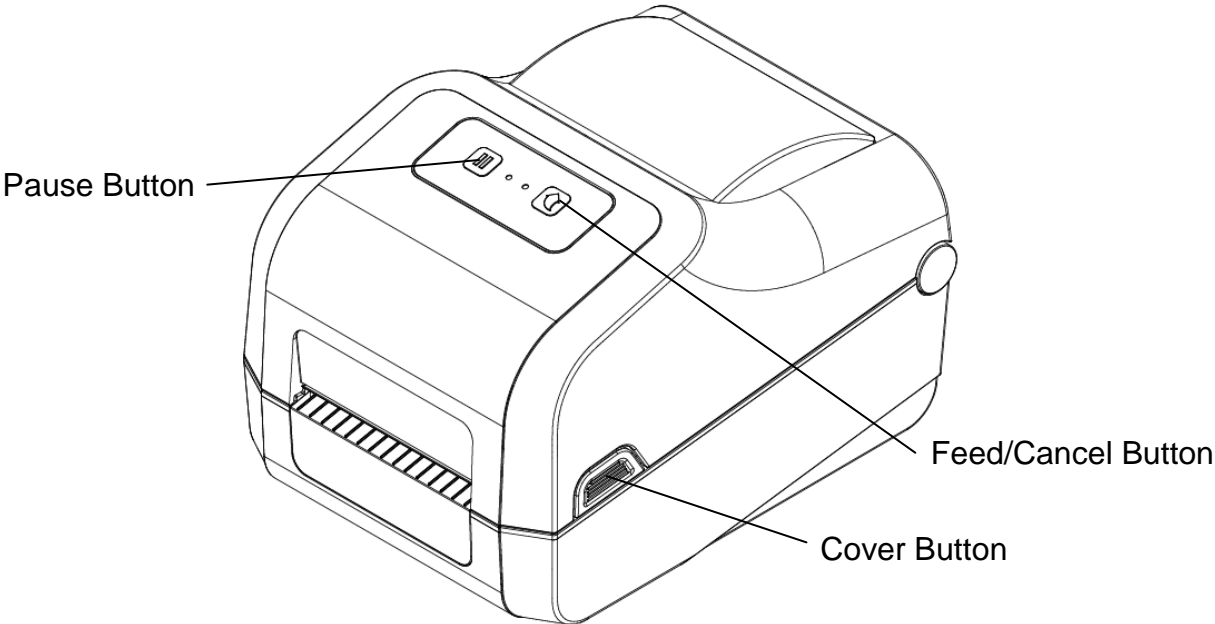

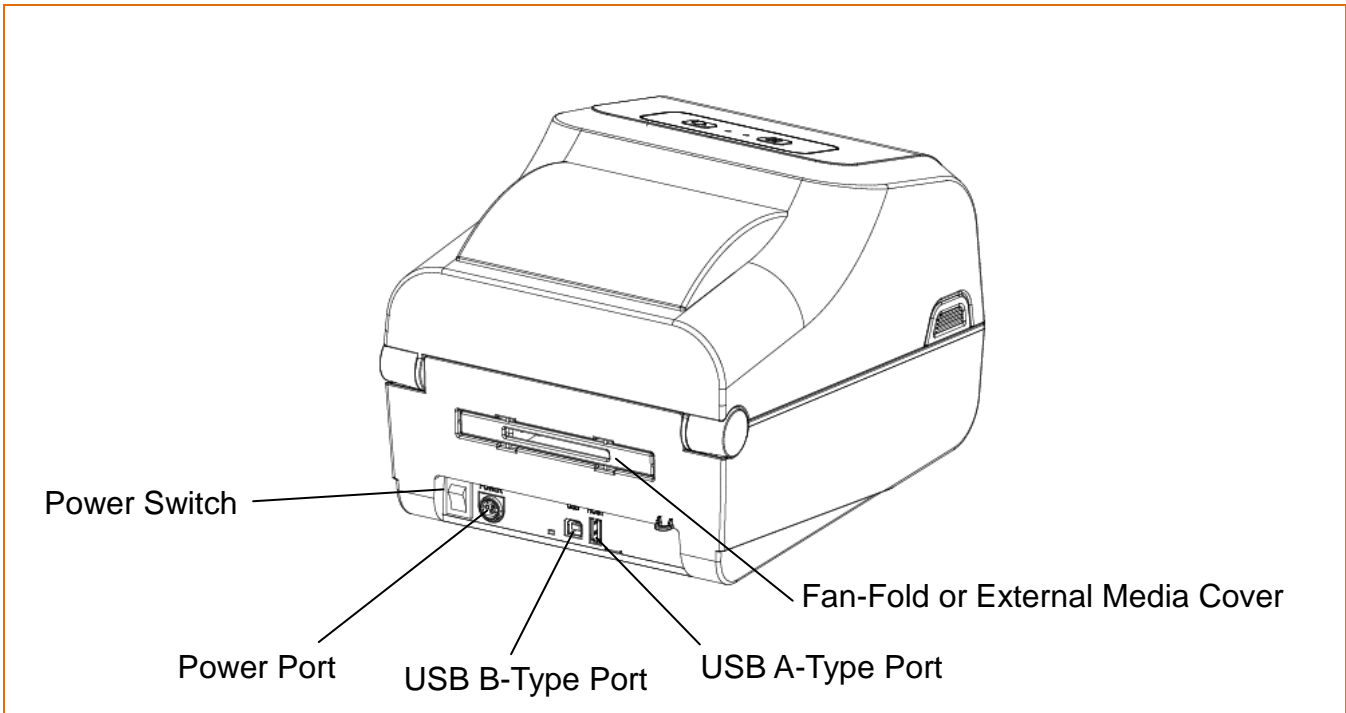

3. Installation & Usage

3-1 Printer Installation Placings

- Install the printer in a location that meets the following conditions.
 - Allow sufficient space around the printer for proper ventilation.
 - Install the printer on a flat and level surface.
 - Avoid humid environment.

3-2 Power Connection

- Connect power to the printer as shown below.

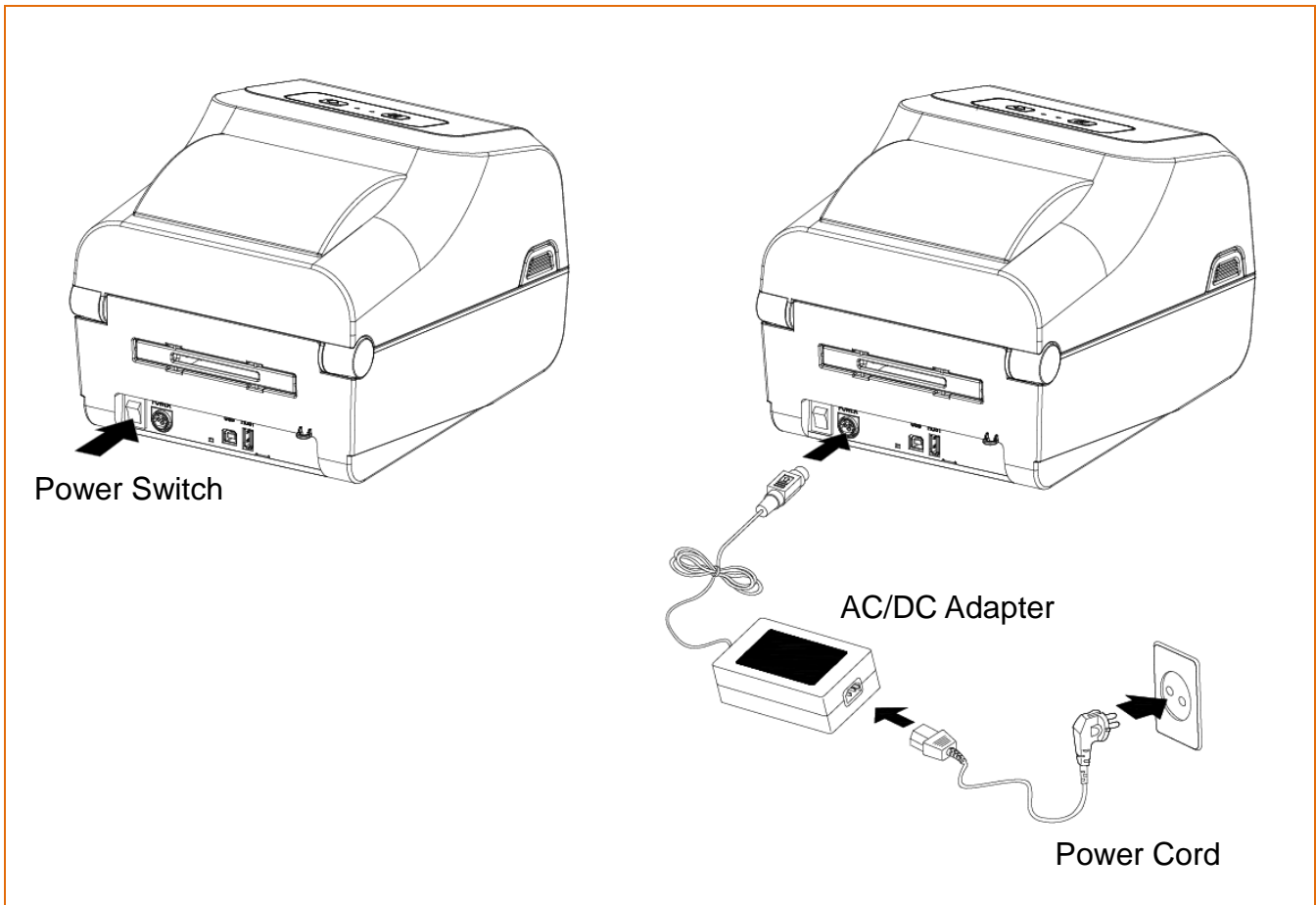

- 1) Turn off the printer power switch.
- 2) Check to see that the AC/DC adapter voltage matches that of the power source.
- 3) Connect the AC/DC adapter jack to the printer power port.
- 4) Connect the power cord to the AC/DC adapter.
- 5) Connect the power cord to a power source/outlet.

- Only use a power supply provided by BIXOLON. BIXOLON shall bear no responsibility for damage caused by using a third-party power supply.
- Check the power supply's label to check its electronic specs.
- For the safety of people and equipment, please use the appropriate power cord for your country or region.
- When removing the power supply, make sure you have a firm grasp of power connector and the printer, then pull horizontally.
- Pay attention to the direction in which you insert the power cable.

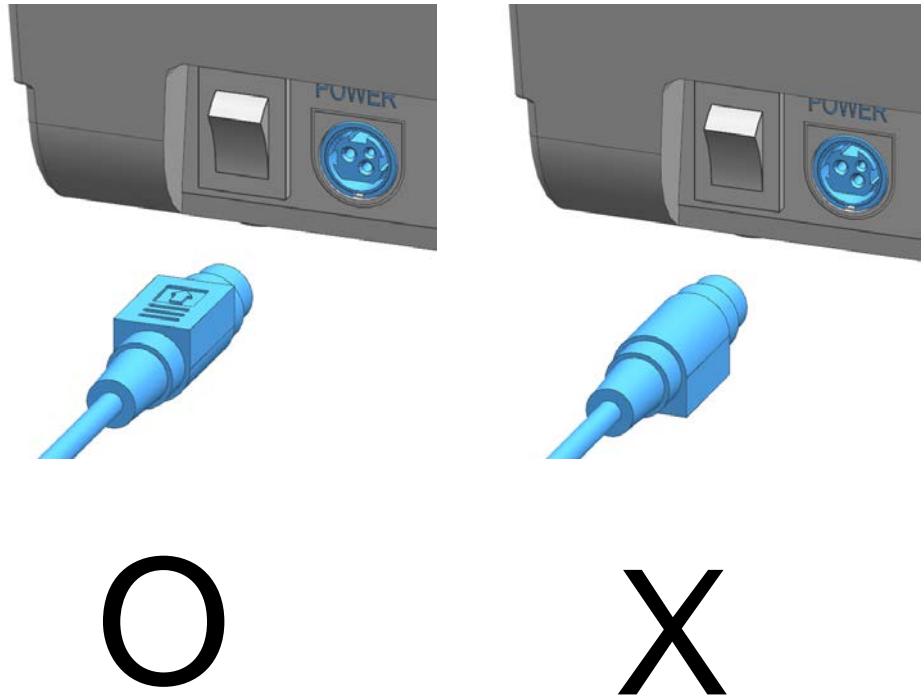

 **Caution**



 **Warning**

- **Be sure to turn off the printer before connecting the power connector to the printer. This can cause serious electrical damage and bodily injury.**
- **Do not operate the printer and power supply in a humid environment. This can cause serious electrical damage and bodily injury.**
- **Do not connect an input voltage beyond the specifications of the power supply. This may result in product damage and fire.**

3-3 Interface

 Note	<p>Shielded cables must be used to prevent radiation and reception of electrical noise. Use the shortest possible communication cable to minimize the detection of electrical noise in the cable.</p> <ul style="list-style-type: none">- Serial(RS-232C) Cable (1.8m or less recommended)- USB B-Type Cable (1.8m or less recommended)- LAN(Ethernet) Cable (3m or less, CAT-5 or higher UTP Cable)
 Caution	<ul style="list-style-type: none">- Connecting unshielded communication cables is in violation of EMC standards. Use the cable approved by us.- Do not bundle the communication cable with objects that may cause electrical noise and interference. The printer may be damaged.- Be aware that the product's electronic components may be damaged due to discharging of electrostatic energy that accumulates on the surface of the body or other objects.
 Warning	<p>After turning off the power switch of printer, connect and disconnect the communication cable. This can cause serious electrical damage and bodily injury.</p>

3-3-1 Standard Interface (USB & USB HOST)

Connect the interface cable as shown below.

This printer(standard) supports the following interfaces.

- USB B-Type Cable
- USB A-Type (storage)

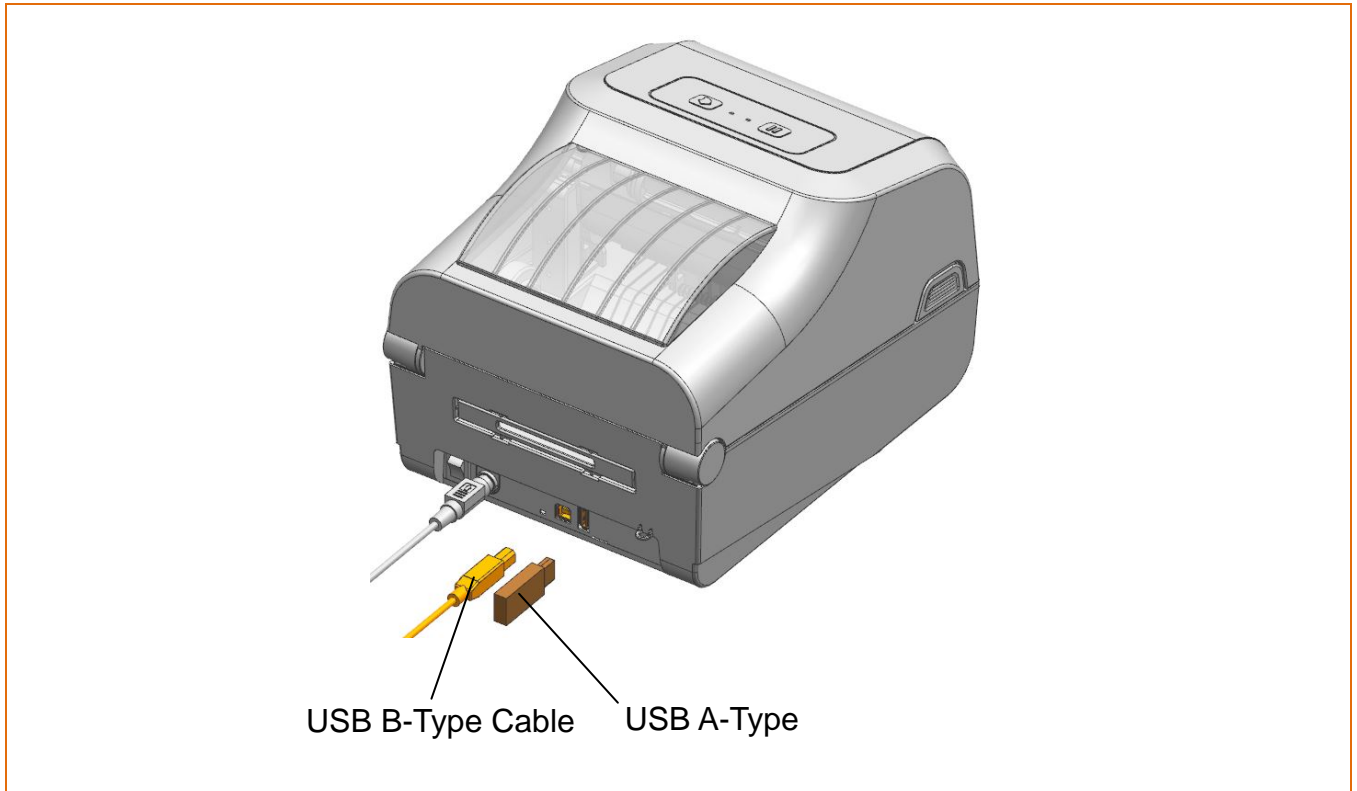

- 1) Turn off the power switch.
- 2) Connect the communication cable to the printer communication port to be used.
 - Connect USB B-Type cable to the USB port.



Be aware that the product's electronic components may be damaged due to discharging of electrostatic energy that accumulates on the surface of the body or other objects.

3-3-2 Optional Interface (USB & USB HOST & Serial & Ethernet)

Connect the interface cable as shown below.

This printer(optional) supports the following interfaces.

- Serial(RS-232C) Cable
- LAN(Ethernet) Cable
- USB B-Type Cable
- USB A-Type (storage)

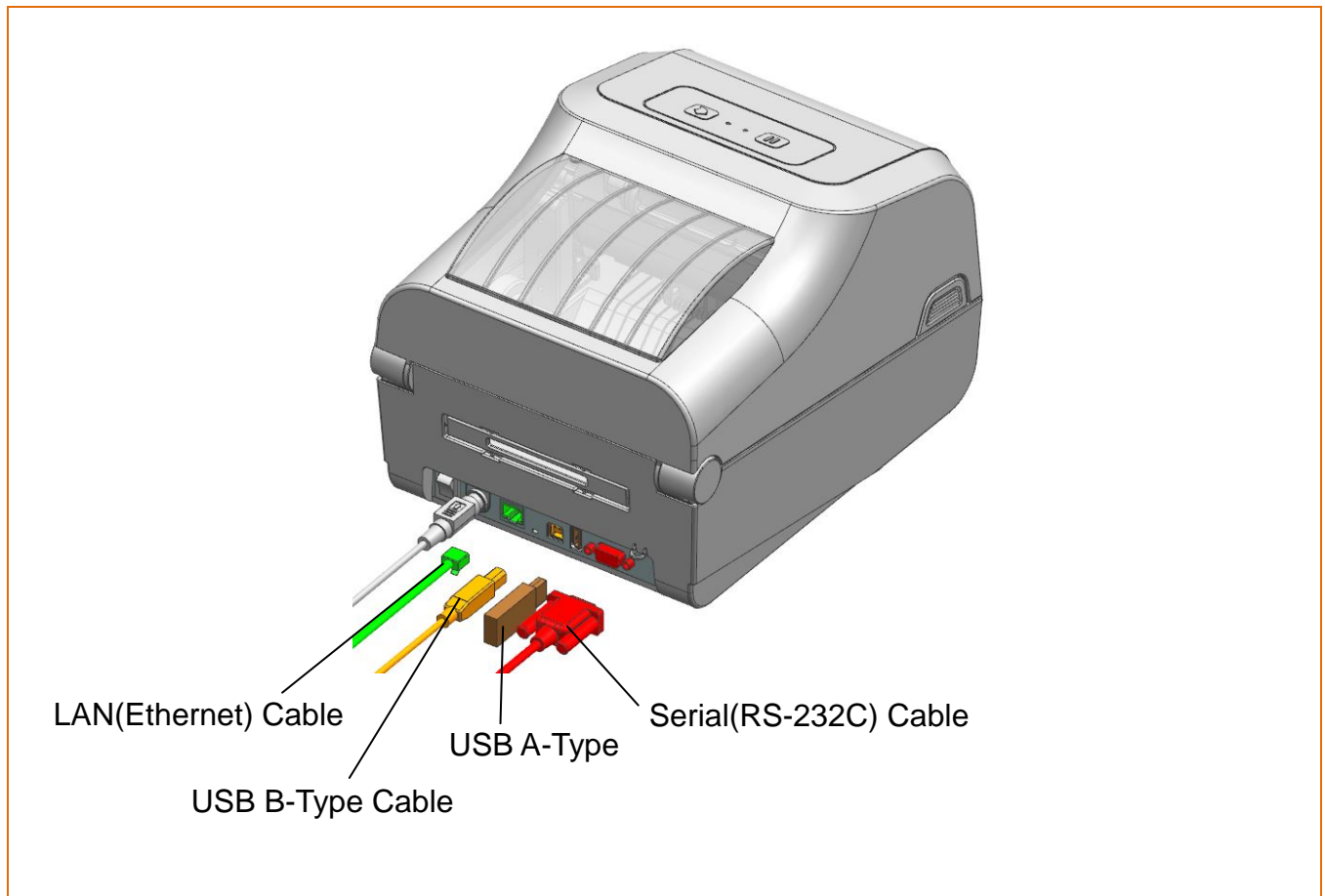

- 1) Turn off the power switch.
- 2) Connect the communication cable to the printer communication port to be used.
 - Connect the serial(RS-232C) cable to the serial port and tighten the screw on both sides.
 - Connect the LAN(Ethernet) cable to the Ethernet port.
 - Connect USB B-Type cable to the USB port.



Caution

Be aware that the product's electronic components may be damaged due to discharging of electrostatic energy that accumulates on the surface of the body or other objects.

3-4 Media Installation

1) Open the media cover as push the cover button on both sides of the media cover.

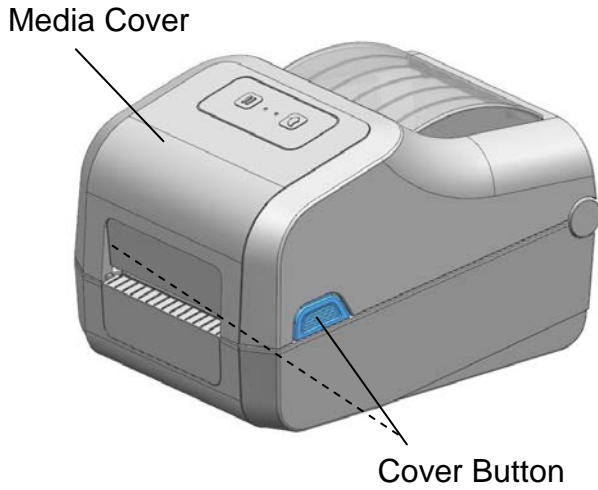

2) Spread the media holder and insert media as shown.

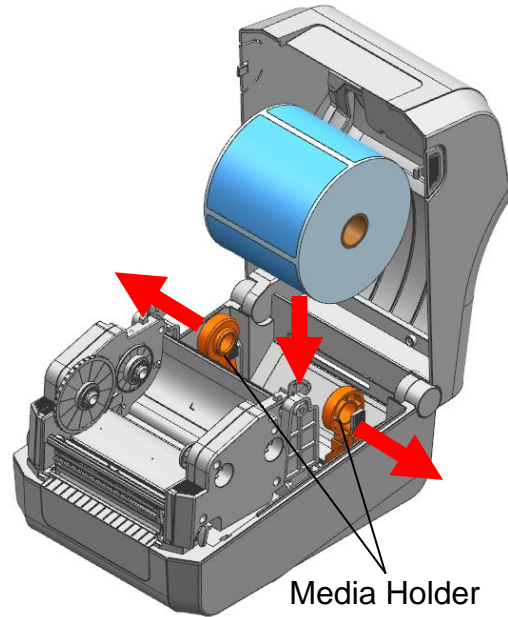

3) Pull the ribbon assembly lever on both sides of the ribbon assembly and open the ribbon assembly.

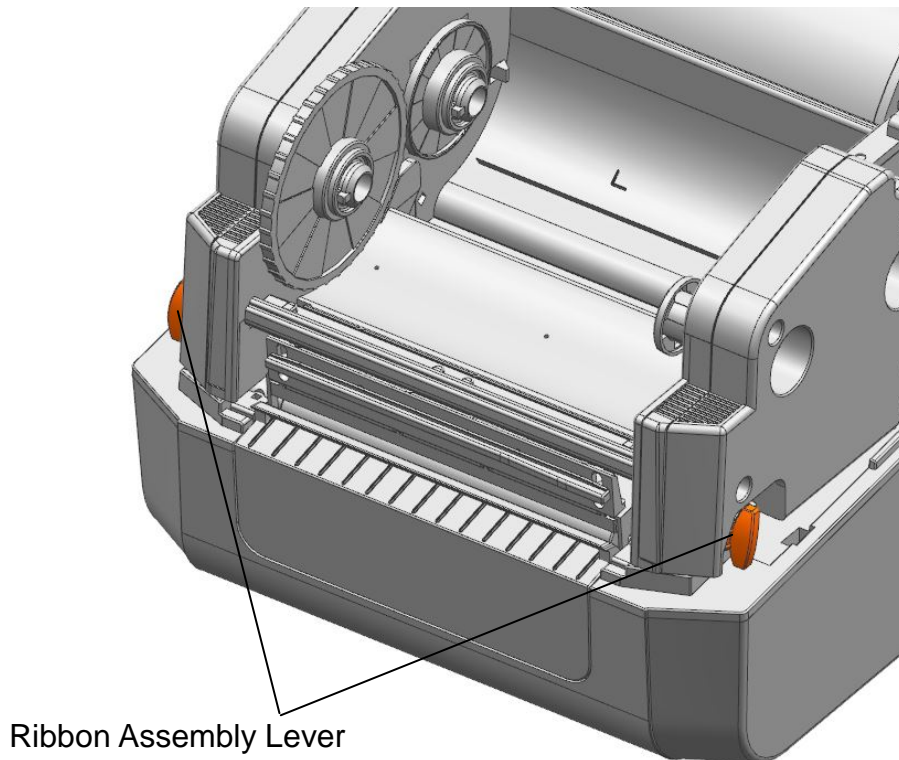

4) Pull the media out to the front of printer.

Adjust the media guides to the width of the media.

* Whether the media is rolled outside or inside, the printing side must face up.

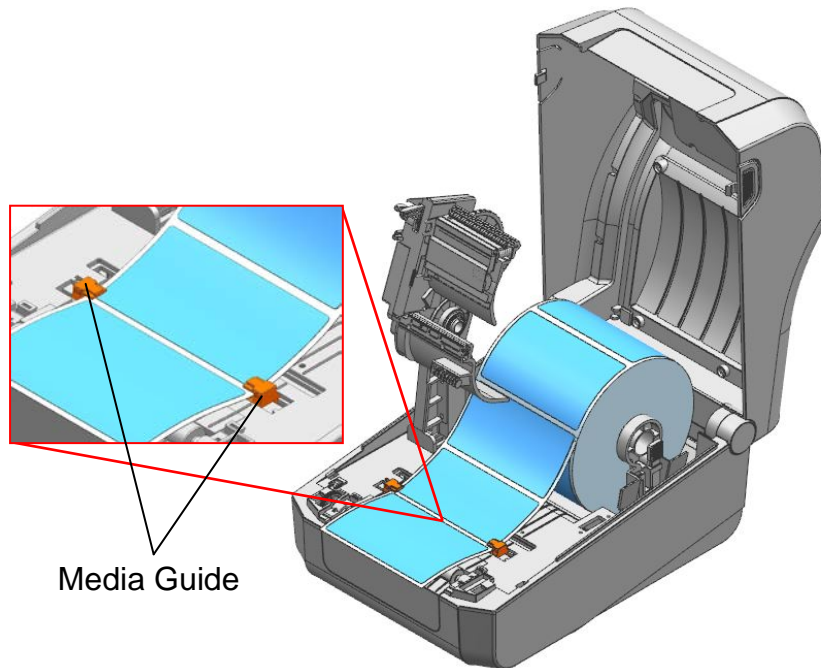

5) If you use black mark or notch media roll, please lift up the media and match the sensor position to the black mark or notch.

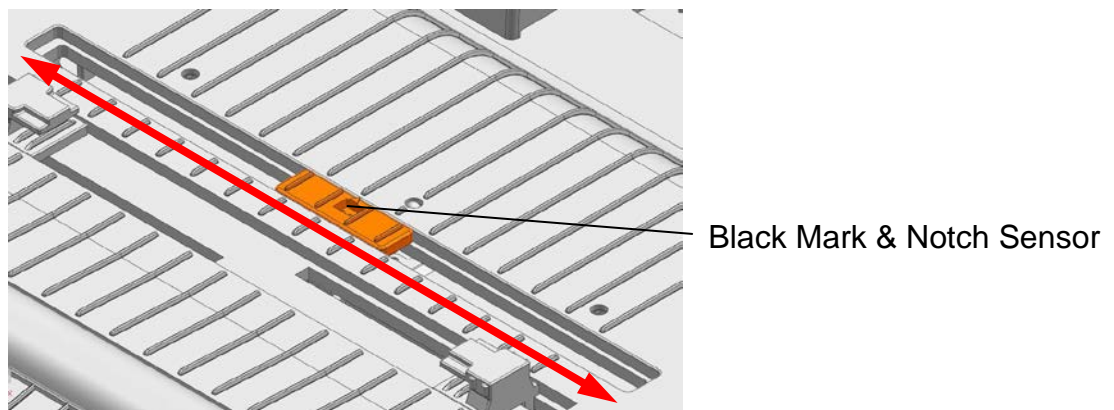

⚠ Caution

- When opening or closing the cover, be careful not to pinch your fingers.
- Do not open the print head levers while the printer is printing.
The printer may be damaged.
- Change the media when the printer is not receiving data, or data may be lost.

⚠ Warning

The print head gets extremely hot while printing or after the printing, this can cause serious burns. Do not touch the print head.

3-5 Ribbon Installation

3-5-1 Type of Ribbon

1) Type by Film Coating Location

- This printer supports ribbons facing outward only.

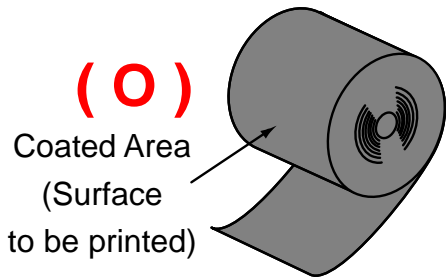

Outside Ribbon

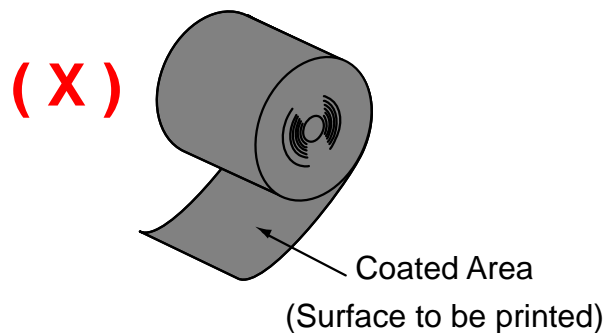

Inside Ribbon



Note

Follow the procedure described below to determine the coating surface of the ribbon.

- Ribbon test using adhesive material
 - Perform contact test in order to determine which side is coated if there are useable labels.
- Complete the following steps to carry out the contact test
 - Remove the liner from the label
 - Put a piece of adhesive surface of the label on the outer/inner surface of the ribbon, and apply pressure.
 - Remove the label from the ribbon
 - Check whether adhesive surface of the label is stained by black ink ribbon.

2) Type by Roll Core

- This printer can be used to 1 inch or 0.5 inch core ribbon.
- For a 1 inch core, a roll core must be used.
- The holder ribbon and roll core of the fully used ribbon must be reused.
Do not discard.

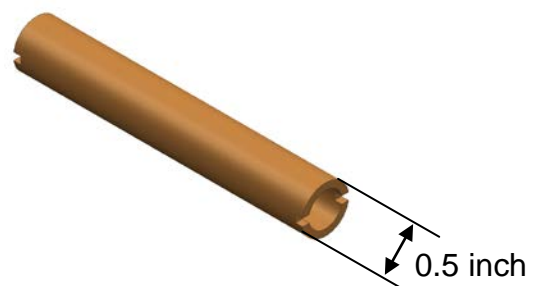
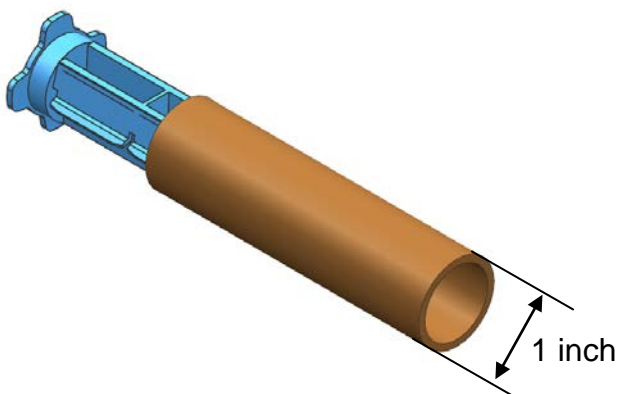

3-5-2 Inserting a 1 Inch Core Ribbon

1) Insert the Holder Ribbon into the core and ribbon. (keep note of ribbon printing direction)

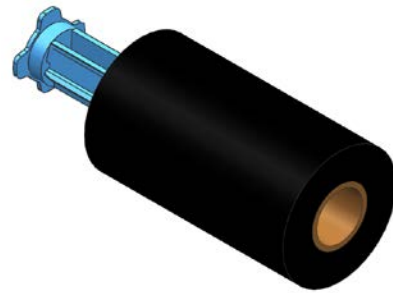
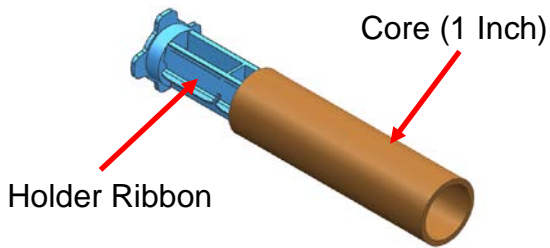

2) Open the ribbon assembly and insert the ribbon and core by pushing to the right.

3) Apply tape to the core of the ribbon.

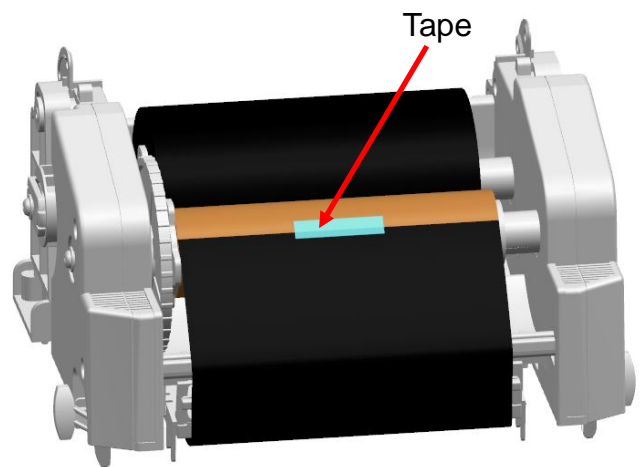
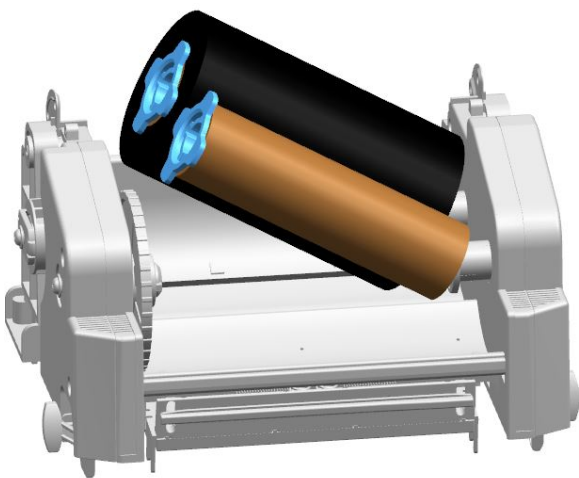

4) Close the ribbon assembly.

3-5-3 Inserting a 0.5 Inch Core Ribbon

1) Open the ribbon assembly and insert the ribbon and core by pushing to the right. (keep attention of ribbon printing direction)

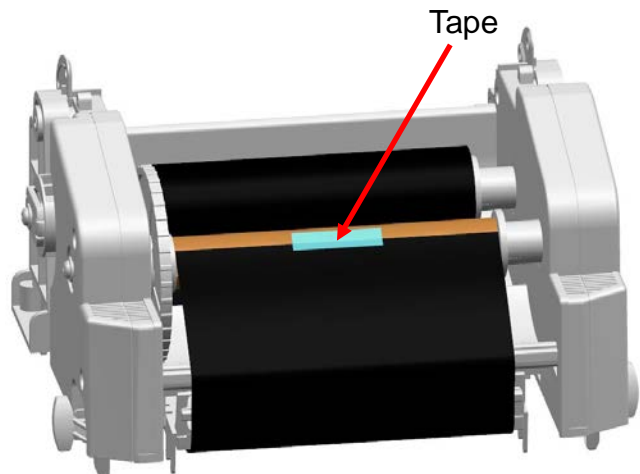
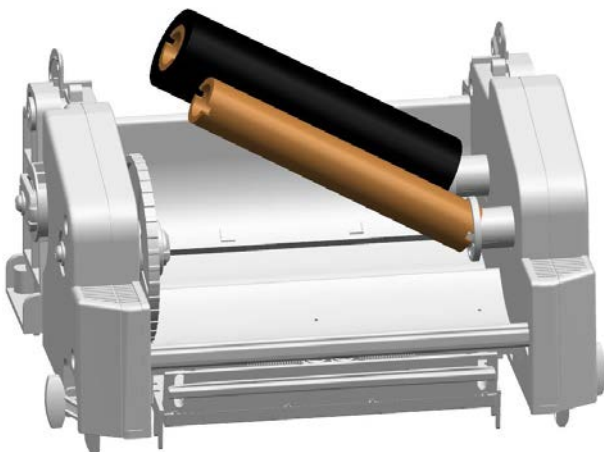

2) Apply tape to the core of the ribbon.

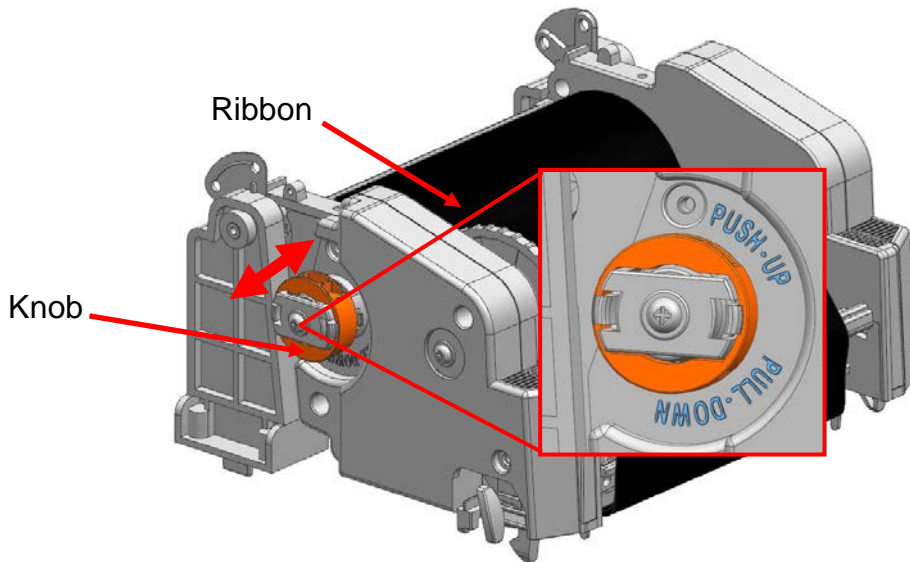

3-5-4 Knob Adjust Method According to Ribbon Type

Use printer after adjusting knob correctly, according to ribbon length and width.
 PUSH-UP state of knob to which being inward is the factory default specification and you can push or pull the knob.
 Please note that push or pull operation affects print quality and operation.

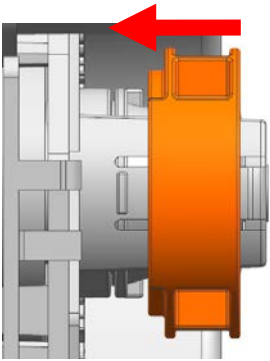
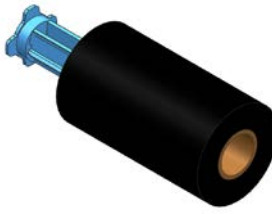
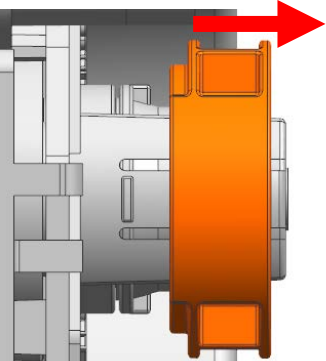
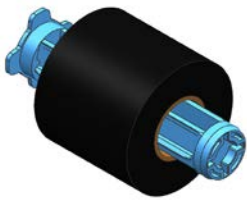

Knob Status	Ribbon Type	
 <p>PUSH-UP</p>	 <p>≈ 300m (1 inch core) Ribbon</p>	
 <p>PULL-DOWN</p>	 <p>≈ Under 2 Inches Width (1 inch Core) Ribbon</p>	 <p>≈ 74m (0.5 inch Core) Ribbon</p>

3-5-5 Narrow Ribbon Installation

When using ribbons of widths of 110mm or lower, install in a centered position on the holder ribbon.

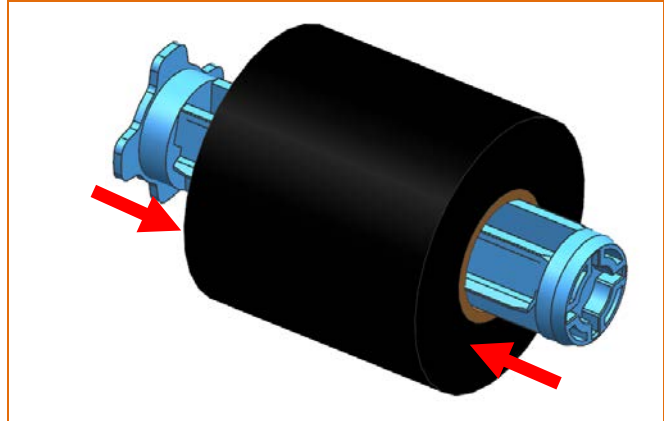

3-5-6 Ribbon Removal

- 1) Cut the ribbon.
- 2) Open the ribbon assembly and remove the ribbon and core by pushing to the right.
- 3) Remove the holder ribbon from the ribbon and core.

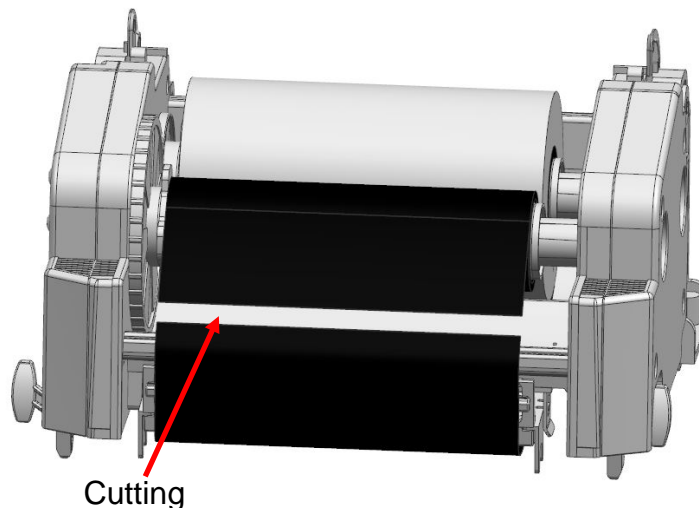

3-5-7 Ribbon Sensor Activation

Check the settings related to ribbon detection sensor if printing does not stop when the printer is out of ribbon or ribbon is broken.

* Ribbon detection sensor can be enabled by command control. And default setting can be changed by Unified Label Utility-II.





- When replacing a ribbon, keep affixed the core of the fully used ribbon to the ribbon coiling portion on the other side and do not discard as its use is required.
- As the ribbon holder is required for continuous use, make sure not to misplace it.

3-6 How to Use the Ribbon Guide

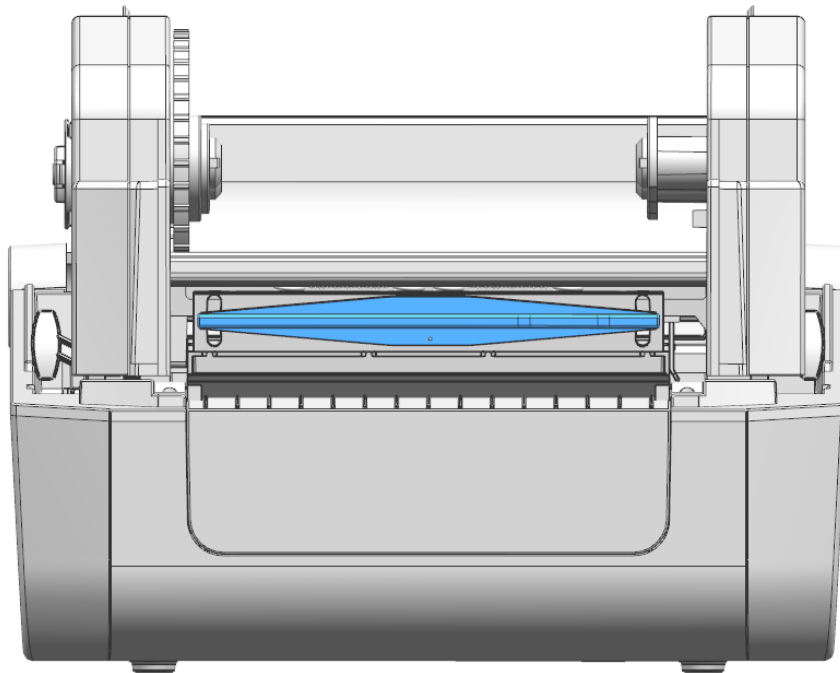
Wrinkles can be improved by adjusting on the ribbon guides.

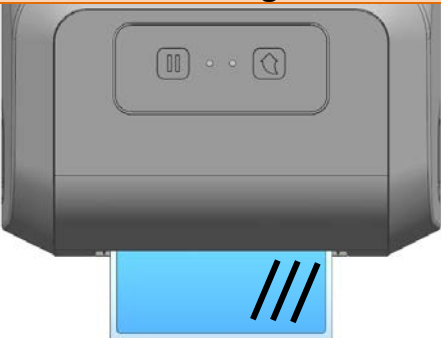
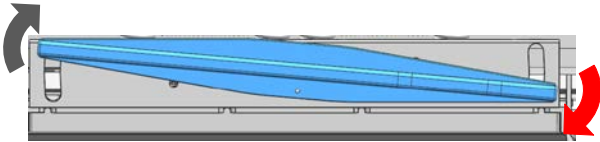
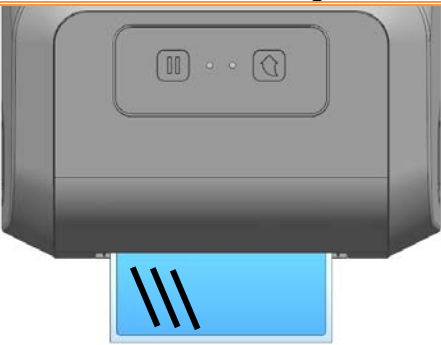
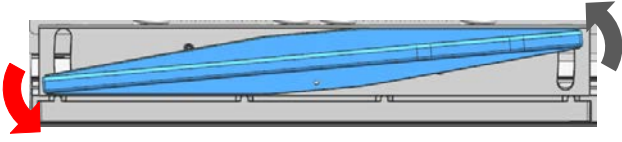

Media Printing Status	Adjustment Method
 <p data-bbox="284 1420 544 1451">Wrinkles on the Right</p>	 <p data-bbox="852 1330 1326 1361">Lower the right side of the guide.</p>
 <p data-bbox="293 1807 537 1839">Wrinkles on the Left</p>	 <p data-bbox="863 1727 1315 1758">Lower the left side of the guide.</p>

 **Caution** Do not adjust ribbon guide while the printer is printing. The printer may be damaged.

3-7 Button & LED (Standard Model)

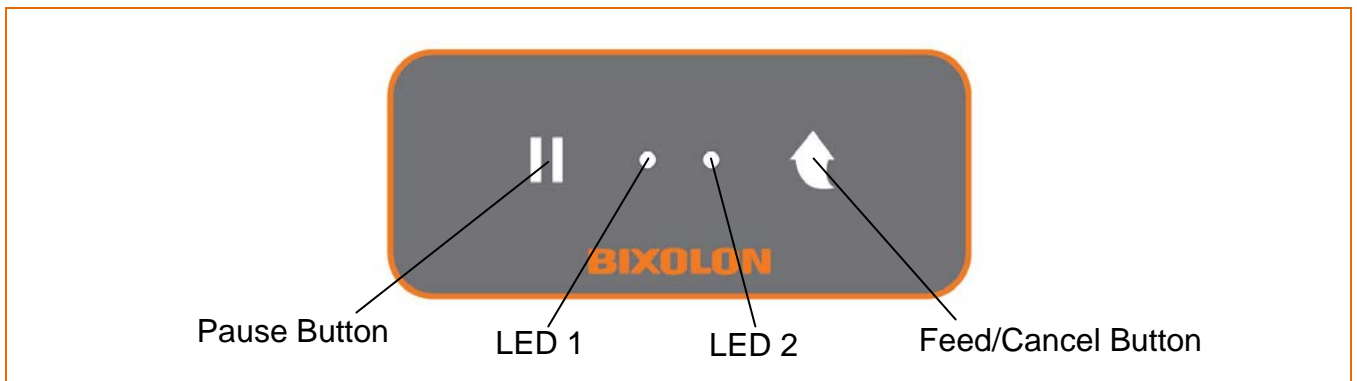

3-7-1 Button Operations

Printer state before operation	Button		Operation procedure	Printer operation mode
	Feed/Cancel	Pause		
Power OFF	Press	-	Apply power while pressing the button (Hold the button until the printer starts self-test printing)	Self-test Printing Mode.
Print Standby	Press	-	Press the button	Feed Mode
Print Standby	-	Press	Press the button for two seconds	Stand-alone Configuration Mode
During Printing	-	Press	Press the button for two Seconds	Print Pause Mode
During Printing	Press	-	Press the button for two Seconds	Print Cancel Mode
Print Pause Mode	Press	-	Press the button	Print Cancel Mode





3-7-2 LED Indicator For Various Printer Statuses

LED 1		LED 2		Printer Operation Status	
Color	Status	Color	Color		
Green	On	Green	On	Print Ready Mode	Ready Mode
Green	On	Red	Blink	Print Cancel Mode	Wait For Button Input
Green	Blink	Red	On	Print Is Paused Temporarily	Wait For Button Input
Green	Blink	Green	Blink	Print Standby Mode	Wait For Button Input
Orange	On	Orange	On	Mode Switching	Mode Switching Notification
Red	On	Orange	On	Error Mode	Media Jam (gap/black mark is not recognized)
Red	On	Green	Blink	Error Mode	Printer Head Overheating
Red	On	Orange	Blink	Error Mode	No Media
Red	On	Red	Blink	Error Mode	Media Cover Open
Red	On	-	Off	Error Mode	Media Calibration Failure
Red	Blink	Red	Blink	Error Mode	Auto-Cutter Error

3-8 Button & LCD (LCD Model)



3-8-1 Button Operation

Printer state before operation	Button	Explanation
Print Ready	 Menu Move	Move to the next menu (The menu moves from the top left to the bottom right)
Print Ready	 Menu Select	Select menu or change value
In Menu or Print Ready	 Function Button 1	Pause , Print, Save, Main screen display
In Menu or Print Ready	 Function Button 2	Feed, Cancel, Previous screen display

3-8-2 Interface Status Icon

User can check the status and setting information through the LCD.



Icon	Explanation
	Bluetooth is not connected to the host
	Bluetooth is connected to the host
	Authentication is failed
	Not connected to AP
	Connected to AP, Strength: 4
	Connected to AP, Strength: 3
	Connected to AP, Strength: 2
	Connected to AP, Strength: 1
	Ethernet is connected
	USB storage is connected
	Receiving data, Printing

3-8-3 Menu Composition

Setting	Sub menu
	Width (Print Width)
	Length (Print Length)
	Direct (Print Direction)
	Speed (Print Speed)
	Density (Print Density)
	Method (Print Method)
	Type (Media Type)
	Tear off (Tear Off)
	Offset (Print Offset)
	Mode (Print Mode)
	Pwr act (Power Up Action)
	Head cls (Print Head Close)

Interface	Sub menu			
	Serial	Baud Rate		
		Data Bit		
		Parity		
		Stop Bit		
		Handshk (Host Handshake)		
	Ethernet	IP Protocol		
		IP Address		
		Subnet Mask		
		Gateway		
		MAC Address		
	WLAN	Channel		
		Network		
		ESSID (AP ID)		
		Auth (Authentication)		
		Encrypt (Encryption)		
		WEP Password		
		PSK Password		
		IP Protocol		
		IP address		
		Subnet Mask		
		Gateway		
		Smart Connect Act (Smart Connect Active)		
		Bluetooth	Device Name	
	Pairing		Pincode	
			SSP (Secure Simple Pairing)	
	MAC Address			
	Mode		BLE (Bluetooth Low Energy)	
			STD (Standard Mode)	Connect Mode Auth&Enc (Authentication & Encryption)

Sensor	Sub menu
	Gap Cal (Gap Calibration)
	Black Mark Cal (Black Mark Calibration)

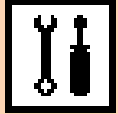
Tools	Sub menu		
	Self prt (Self-Test)		
	Reset (Factory Reset)		
	Dump (Data Dump Mode)		
	Head Chk (Printer Head Check)		
	USB Num (USB Serial Number)		
	Demo prt (Demo Print)		
	Files	Saved (Saved File)	Template
			Image
			Fonts (Download Fonts)
			E Drive (Flash Memory)
			A Drive (USB Storage)
			PRT Set (Printer Setting)
	Files	Twin (Twin Function)	Template
			Image
Fonts (Download Fonts)			
Files	F/W Update		

Information	Sub menu
	Info (Printer Info)
	Support

3-8-4 Setting Menu Explanation

Menu	Explanation
Width (Print Width)	Explanation Setting media width[dots] Function to adjust image buffer size according to print width Default Value - 203dpi : 864 dots (108mm) - 300dpi : 1,248 dots (105.7mm) Maximum Value - 203dpi : 864 dots (108mm) - 300dpi : 1,248 dots (105.7mm)
Length (Print Length)	Explanation Setting media length[dots] Function to adjust image buffer size according to print length Default Value 203dpi : 1,225 dots (153mm) 300dpi : 1,811 dots (153mm) Maximum Value - 203dpi : 8,000 dots (1,000mm) - 300dpi : 11,820 dots (1,000mm)

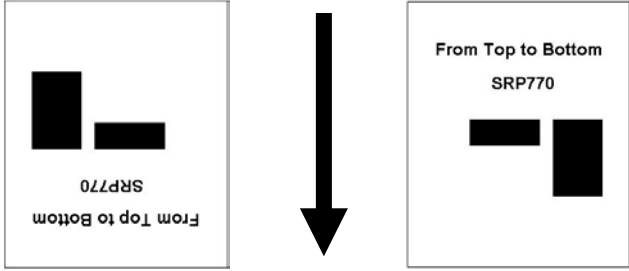
<p style="text-align: center;">Direct (Print Direction)</p>	<p>Explanation Setting print direction Top to bottom: Printing from top to bottom Bottom to Top: Printing from bottom to top</p> <p>Default Value Bottom to Top</p> <p>Variable Value Bottom to Top, Top to Bottom</p> <p style="text-align: center;">Printing Direction</p> <div style="text-align: center;">  <p style="display: flex; justify-content: space-around; width: 100%;"> Top to bottom Bottom to top </p> </div>
<p style="text-align: center;">Speed (Print Speed)</p>	<p>Explanation Setting print speed[ips]</p> <p>Default Value 203dpi : 5ips 300dpi : 3ips</p> <p>Variable Value - 203dpi : 3~6ips - 300dpi : 2~4ips</p>

Density (Print Density)	Explanation Setting print density Default Value 203dpi : 20 300dpi : 20 Variable Value 0~30
Method (Print Method)	Explanation Setting print method Default Value Trans(Thermal Transfer) Variable Value Direct (Direct Thermal), Trans(Thermal Transfer)
Type (Media Type)	Explanation Setting media type Default Value Gap Variable Value - Gap - Black Mark - Continuous
Tear off	Explanation Setting media position[dots] for tear off after printing or feed Default Value 0 Variable Value -100 ~ 100

Offset (Print Offset)	Explanation Setting top print position[dots] Default Value 0 Variable Value -100 ~ 100
Mode (Print Mode)	Explanation Setting print mode suitable to the printer option Default Value Tear off Variable Value Tear off, Cutter
Pwr act (Power Up Action)	Explanation Setting the action for the printer after the power-up sequence. Default Value NO FEED Variable Value NO FEED, FEED, CAL LENGTH (Media Calibration), LABEL LENGTH (Setting Media Length)
Head cls (Print Head Close)	Explanation Setting the action for the printer when you close the printer cover. Default Value STANDBY Variable Value STANDBY, NO FEED, FEED, CAL LENGTH (Media Calibration), LABEL LENGTH (Setting Media Length)

3-8-5 Interface Menu Explanation**3-7-5-1 Serial**

List	Explanation
Baud Rate	Explanation Setting the baud rate Default Value 115200 Variable Value 9600, 19200, 38400, 57600, 115200
Data Bit	Explanation Setting the data bit Default Value 8 Variable Value 7, 8
Parity	Explanation Setting the parity Default Value None Variable Value Even, Odd, None
Stop Bit	Explanation Setting the stop bit Default Value 1BIT Variable Value 1BIT, 2BIT
Handshk (Handshake)	Explanation Setting the handshake Default Value RTS_CTS Variable Value RTS_CTS, DTR_DSR, XON_XOFF

3-8-5-2 Ethernet

List	Explanation
IP Protocol	Explanation Setting IP assignment method Default Value DHCP Variable Value DHCP, Static IP
IP Address	Explanation Setting IP Address method Default Value Static IP: 192.168.192.123 DHCP: 0.0.0.0 Variable Value 0 ~ 255
Subnet Mask	Explanation Setting subnet mask Default Value Static IP: 255.255.255.0 DHCP: 0.0.0.0 Variable Value 0 ~ 255
Gateway	Explanation Setting gateway Default Value Static IP: 192.168.192.254 DHCP: 0.0.0.0 Variable Value 0 ~ 255
MAC Address	Explanation Indicating MAC address

3-8-5-3 WLAN

List	Explanation
Channel	<p>Explanation Setting channel when creating Adhoc network</p> <p>Default Value 6</p> <p>Variable Value 1 ~ 14</p>
Network	<p>Explanation Setting WLAN operation mode</p> <p>Default Value SoftAP</p> <p>Variable Value SoftAP, Infra(Infra structure), Adhoc, P2P</p>
ESSID (AP ID)	<p>Explanation Setting the ID of AP to be accessed</p>
Auth (Authentication)	<p>Explanation Setting WLAN authentication method</p> <p>Default Value Open</p> <p>Variable Value Open, Shared Key, WPA1PSK, WPA2PSK, WPA1EAP, WPA2EAP</p>
Encrypt (Encryption)	<p>Explanation Setting WLAN encryption method</p> <p>Default Value None</p> <p>Variable Value None, WEP64/128, TKIP, AES, AES+TKIP</p>
WEP Password	<p>Explanation Setting WEP password</p>
PSK Password	<p>Explanation Setting PSK password</p>

IP Protocol	Explanation Setting IP assignment method Default Value DHCP Variable Value DHCP, Static IP
IP address	Explanation Setting IP address Default Value Static IP: 192.168.1.1 DHCP: 0.0.0.0 Variable Value 0 ~ 255
Subnet Mask	Explanation Setting subnet mask Default Value Static IP: 255.255.255.0 DHCP: 0.0.0.0 Variable Value 0 ~ 255
Gateway	Explanation Setting gateway Default Value Static IP: 192.168.1.254 DHCP: 0.0.0.0 Variable Value 0 ~ 255
Smart Connect Act (Smart Connect Activate)	Explanation After searching a Smart Connection Act Enabled printer with the smart phone app, enable or disable the function synchronizing Wi-Fi login information connected to the smart phone. Default Value Disable Variable Value Disable, Enable

3-8-5-4 Bluetooth

List		Explanation	
Device Name		Explanation Name of Device	
Pairing	Pincode	Explanation Changes required pin code to connect	
	SSP (Secure simple pairing)	Explanation Secure simple pairing Default Value Disable Variable Value Disable, Just Works, Numeric Comparison, Passkey Entry	
MAC Address		Explanation Bluetooth device MAC address	
Mode	BLE (Bluetooth Low Energy)	Explanation Bluetooth Low Energy Default Value Disable Variable Value Disable, Enable	
	STD (Standard Mode)	Connect Mode	Explanation Setting Bluetooth connection mode Default Value Mode2 Variable Value Mode1, Mode2, Mode3
		Auth&Enc (Authentication &Encryption)	Explanation Setting Bluetooth authentication and encryption function Default Value Enable Variable Value Enable, Disable

3-8-6 Sensor Menu Explanation

List	Explanation
Gap Cal (Gap Calibration)	Explanation Detect media gap automatically.
Black Mark Cal (Black Mark Calibration)	Explanation Detect media black mark automatically.

3-8-7 Tools Menu Explanation

List	Explanation		
Self prt (Print Self-Test)	Explanation Prints for self-test		
Reset (Factory Reset)	Explanation Initializes the printer settings to factory default		
Dump (Data Dump Mode)	Explanation The received data check when the printer does not work properly. Default Value Disable Variable Value Disable, Enable		
Head Chk (Print Head Check)	Explanation Dot-out check of head through printing		
USB Num (USB Serial Number)	Explanation Checks USB serial number		
Demo prt (Demo Print)	Explanation Demo format printing function		
Files	Saved (Saved File)	Template	Refer 3-6-7-1 Saved File
		Image	
		Fonts (Download Fonts)	
		E Drive (Flash Memory)	
	Twin (Twin Function)	A Drive (USB Storage)	Refer 3-6-7-2 Twin Function
		PRT Set (Printer Setting)	
		Template	
	F/W Update	Image	Refer 3-6-7-3 F/W Update
		Fonts (Download Fonts)	





3-8-7-1 Saved File

Displays the list of object files stored in the printer.

List	Explanation
Template	Template list stored in the printer
Image	Image list stored in the printer (*.pcx)
Fonts (Download Fonts)	Download font list stored in the printer
E Drive (Flash memory)	Saved object files in E drive
A Drive (USB memory)	Saved object files in A drive

3-8-7-2 Twin Function

Saves the current printer settings, save files (templates, images, download fonts) to another printer using USB, or loads the settings of another printer.

List	Explanation
<p>PRT Set (Printer Setting)</p>	<p>Explanation Save printer settings to a USB storage device, or load the print settings from USB storage.</p> <p>File path F:\configuration</p> <p>• Save Function Explanation</p> <ul style="list-style-type: none"> - Connect a USB storage to the printer. - Select Save on the menu using the move button() and select button(). - The printer_config file is created in the configuration folder of USB storage device. (The configuration folder is automatically created) <p>• Load Function Explanation</p> <ul style="list-style-type: none"> - Check whether the printer_config file exists in the configuration folder of the USB storage device. - Connect the USB storage to the printer. - Select Load on the menu using the move button() and select button(). - Loading message>Loading...) is displayed while loading, and when loading is completed, USB loading completion(>Load Ok) message is displayed. - Check the changes of the printer's settings.



Template**Explanation**

Save template files to a USB storage device, or load the templates from USB storage.

File path

F:\ USER_AREA_TEMPLATES

• Save Function Explanation

- Connect a USB storage to the printer.
- Select Save on the menu using the move button() and select button() .
- Template files are stored in the USER_AREA_TEMPLATES folder of USB storage device.
(USER_AREA_TEMPLATES folder is automatically created)

• Load Function Explanation











- Check whether a template files exist in the USER_AREA_TEMPLATES folder of the USB storage device.
- Connect the USB storage to the printer.
- Select Load on the menu using the move button() and select button() .
- Loading message(Loading...) is displayed while loading, and when loading is completed, USB loading completion (Load Ok) message is displayed.
- Go to Save File menu then, check the template files are saved to the printer.

Image	<p>Explanation Save image files to a USB storage device, or load the images from USB storage (*.pcx)</p> <p>File path F:\ USER_AREA_PCXImages</p> <p>• Save Function Explanation</p> <ul style="list-style-type: none">- Connect a USB storage to the printer.- Select Save on the menu using the move button() and select button().- Image files are stored in the USER_AREA_PCXImages folder of USB storage device. (USER_AREA_PCXImages folder is automatically created) <p>• Load Function Explanation</p> <ul style="list-style-type: none">- Check whether the image files exist in the USER_AREA_PCXImages folder of the USB storage device.- Connect the USB storage to the printer.- Select Load on the menu using the move button() and select button().- Loading message>Loading...) is displayed while loading, and when loading is completed, USB loading completion(>Load Ok) message is displayed.- Go to Save File menu then, check the image files are saved to the printer.
--------------	--

Fonts (Download Fonts)	<p>Explanation Save download font files to a USB storage device, or load the download font from USB storage.</p> <p>File path F:\ USER_AREA_FONTS</p> <p>• Save Function Explanation</p> <ul style="list-style-type: none">- Connect a USB storage to the printer.- Select Save on the menu using the move button() and select button().- Download Font files are stored in the USER_AREA_FONTS folder of USB storage device. (USER_AREA_FONTS folder is automatically created) <p>• Load Function Explanation</p> <ul style="list-style-type: none">- Check if the downloaded font files exist in the USER_AREA_FONTS folder of the USB storage device.- Connect the USB storage to the printer.- Select Load on the menu using the move button() and select button().- Loading message>Loading...) is displayed while loading, and when loading is completed, USB loading completion (Load Ok) message is displayed.- Go to Save File menu then, check the download font files are saved to the printer.
---------------------------------------	--

3-8-7-3 F/W Update

Firmware can be updated through USB storage.

F/W Update	<p>Explanation Printer firmware update available using the USB storage directly without any communication.</p> <p>File path F:\ FW_DOWNLOAD</p> <p>File name “XD5-4xt_Vxx.xx_STD_mmddyy.flis” in F:\ FW_DOWNLOAD folder.</p> <p>• Download process explanation</p> <ul style="list-style-type: none">- Check firmware file(*.flis) is in FW_DOWNLOAD folder of USB storage.- Connect USB storage to the printer.- Select “F/W Update” from the “Files” menu.- Select “Start” from the “F/W Update” menu using the function button 1 (). <ul style="list-style-type: none">- If message “F/W Update” is displayed, the firmware download has started normally.- After firmware update complete successfully, printer will be rebooted automatically.
-------------------	--

3-8-8 Information Menu Explanation

List	Explanation
Info	Explanation Checking the printer usage information
Support	Explanation Site linking(QR code) for technical support.

4. Self-test

- This function is supported on standard model(without LCD) only.

The self-test checks whether the printer has any problems.

The self-test checks the following;

- 1) Make sure that the media has been installed properly.
- 2) Turn on the power while holding down the Feed/Cancel button(). The self-test begins.
(It takes about 10 seconds before starting self-test)
- 3) The self-test prints the current printer configuration information.
- 4) After the self-test results are printed, a printer enters into print ready mode.





If the printer does not function properly, contact an authorized dealer.

5. Detailed Features

5-1 Stand-alone Configuration Mode

- This function is supported on standard model(without LCD) only.

5-1-1 Start Stand-alone Configuration Mode and execute each function

- 1) The Pause button() is pressed for two seconds while in Print Ready Mode.
- 2) Both LEDs will change to orange color, then release the Pause button()
The printer will be set to Stand-alone configuration mode.
- 3) When the printer enters into this mode, the status of LED 1 and LED 2 are changed sequentially.
- 4) When the Feed/Cancel button() is pressed at specific LED color combination, the corresponding printer operation will be executed.

5-1-2 Function List Of Stand-alone Configuration Mode

Sequence Number	LED 1		LED 2		Printer Operation
	Color	Status	Color	Status	
1	Green	On	Green	Blink4 times	Self Test
2			Orange	Blink4 times	Print File List
3			Red	Blink4 times	Factory Reset
4	Orange	On	Green	Blink4 times	Gap Calibration
5			Orange	Blink4 times	Black Mark Calibration
6			Red	Blink4 times	Data Dump Mode
7	Red	On	Green	Blink4 times	Demo Mode
8			Orange	Blink4 times	Reserved
9			Red	Blink4 times	Delete Downloaded Items

* This information can be printed out by printer self-test.



Caution

Contact the customer center if the printer does not enter stand-alone configuration mode.

5-2 Pause/Cancel

- During multiple-page print jobs, the Pause (⏸), Feed/Cancel button (↶), Function button 1 (⋮) and Function button 2 (⋮) can be used to pause printing and cancel the print job altogether, respectively.

5-2-1 Pause/Resume Function

1) Standard Model

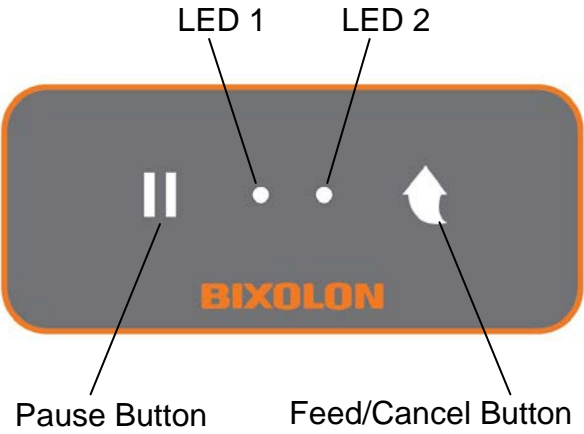
	<ol style="list-style-type: none">1) When printing, press the Pause button (⏸)2) The printer will pause after finishing the current media printing and the status of LED will be as follows.<ul style="list-style-type: none">- LED 1: Green Blink- LED 2: Red On3) While the print job is paused, press the Pause button (⏸) again to resume printing.
---	--

2) LCD Model

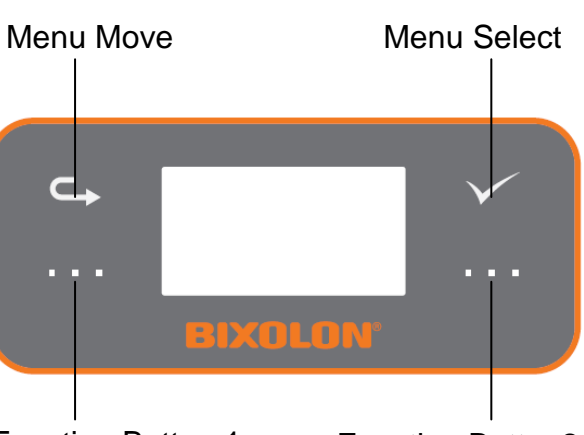

	<ol style="list-style-type: none">1) When printing, press the Function button 1 (⋮).2) The printer will pause after finishing the current media printing and the status of LCD will be as follows.<ul style="list-style-type: none">- LCD Display: PAUSE3) While the print job is paused, press the Function button 1 (⋮) again to resume printing.
---	---

5-2-2 Print Cancellation

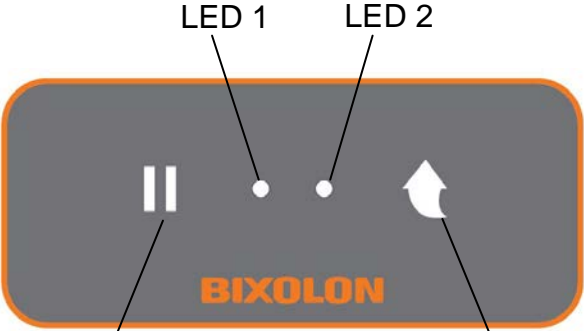

The following processes occur in the print cancellation mode.

- All label printing cancelled
- All data received in the printer communications buffer deleted.
- All received data deleted.

1) Standard Model

	<ol style="list-style-type: none">1) During printing and/or pause mode, press the Feed/Cancel button () enters the print cancellation mode.2) The LED Status in the print cancellation mode can be as follows.<ul style="list-style-type: none">- LED 1: Green On- LED 2: Red Blink3) While in the print cancellation mode, press the Feed/Cancel button () again to return to print ready mode.
---	---

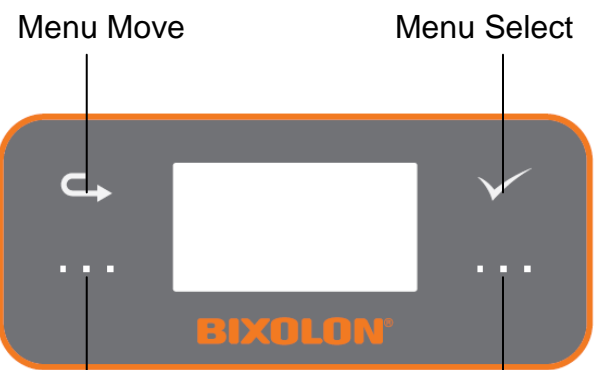
2) LCD Model



	<ol style="list-style-type: none">1) During printing and/or pause mode, press the Function button 2 () enters the print cancellation mode.2) The LCD Status in the print cancellation mode can be as follows.<ul style="list-style-type: none">- LCD Display: Press Cancel3) While in the print cancellation mode, press the Function button 2 () again to return to print ready mode.
---	--



Caution

Contact the authorized dealer if the printer does not execute pause/resume function.

5-3 Smart Media Detection

- Media with gap and black mark can be identified without additional settings.
- 3~5 pages of media will be used depending on the types of media.
- Smart Media Detection function is executed in the followings cases
 - When the printer is installed first time, it is executed by pressing the Feed/Cancel button() for LED model, pressing Function button 2() for LCD model.
 - If the printer is installed first time, printer command will execute Smart Media Detection.
 - When change of media length or type is detected during feeding or printing.
 - When the different media type command is entered from the configured media type.
 - After factory reset.



Caution

If smart media detection fails, please proceed gap or B/M sensor auto-calibration accordingly

5-4 Gap Sensor Auto Calibration Mode

- Gap sensor auto calibration mode is used when the printer does not detect a gap on the media correctly.

Generally a printer is set to detect most types of gap but sometimes it fails to detect and keep feeding the media without a stop when special media used. In such case, use gap sensor auto calibration mode function for a proper detection.

1) Make sure that media roll has been installed properly.

2) Standard Model

Using stand-alone configuration mode, press the Feed/Cancel button() at sequence number 4 gap sensor auto calibration mode (refer to 5-1).

3) LCD Model

In print ready mode the setting menu and move to Sensor -> Gap Cal(Gap Calibration)

and press Function button 1() to process gap sensor auto calibration

* Please refer Tools Menu Explanation (3-6) for more information.



Caution

Contact the customer center if the printer does not execute gap sensor auto calibration mode function.

5-5 B/M Sensor Auto Calibration Mode

- Black mark sensor auto calibration mode is used when the printer does not detect a black mark on the media correctly.

Generally a printer is set to detect most types of black mark but sometimes it fails to detect and keep feeding the media without a stop when special media used. In such case, use black mark sensor auto calibration mode function for a proper detection.

1) Make sure that media roll has been installed properly.

2) Standard Model

Using stand-alone configuration mode, press the Feed/Cancel button () at sequence number 5 black mark sensor auto calibration (refer to 5-1).

3) LCD Model

In print ready mode the setting menu and move to Sensor-> Black Mark Cal(Black Mark Calibration) and press Function button 1() to process black mark sensor auto calibration

* Please refer Tools Menu Explanation (3-6) for more information.



Caution

Contact the customer center if the printer does not execute black mark sensor auto calibration mode function.

5-6 Media Sensor Manual-Calibration

- Manual-calibration of media detection can be used when the printer cannot detect a media gap (or black mark) even after auto-calibration has been executed.

Users can calibrate sensor parameters in detail by using the Unified Label Utility-II program provided by the manufacturer.

The Unified Label Utility-II can be downloaded from the Internet via the BIXOLON website. (www.bixolon.com)

Please make sure the printer is connected and execute the Unified Label Utility-II program. Please the Calibration Setting Manager Button after setting the interface type.

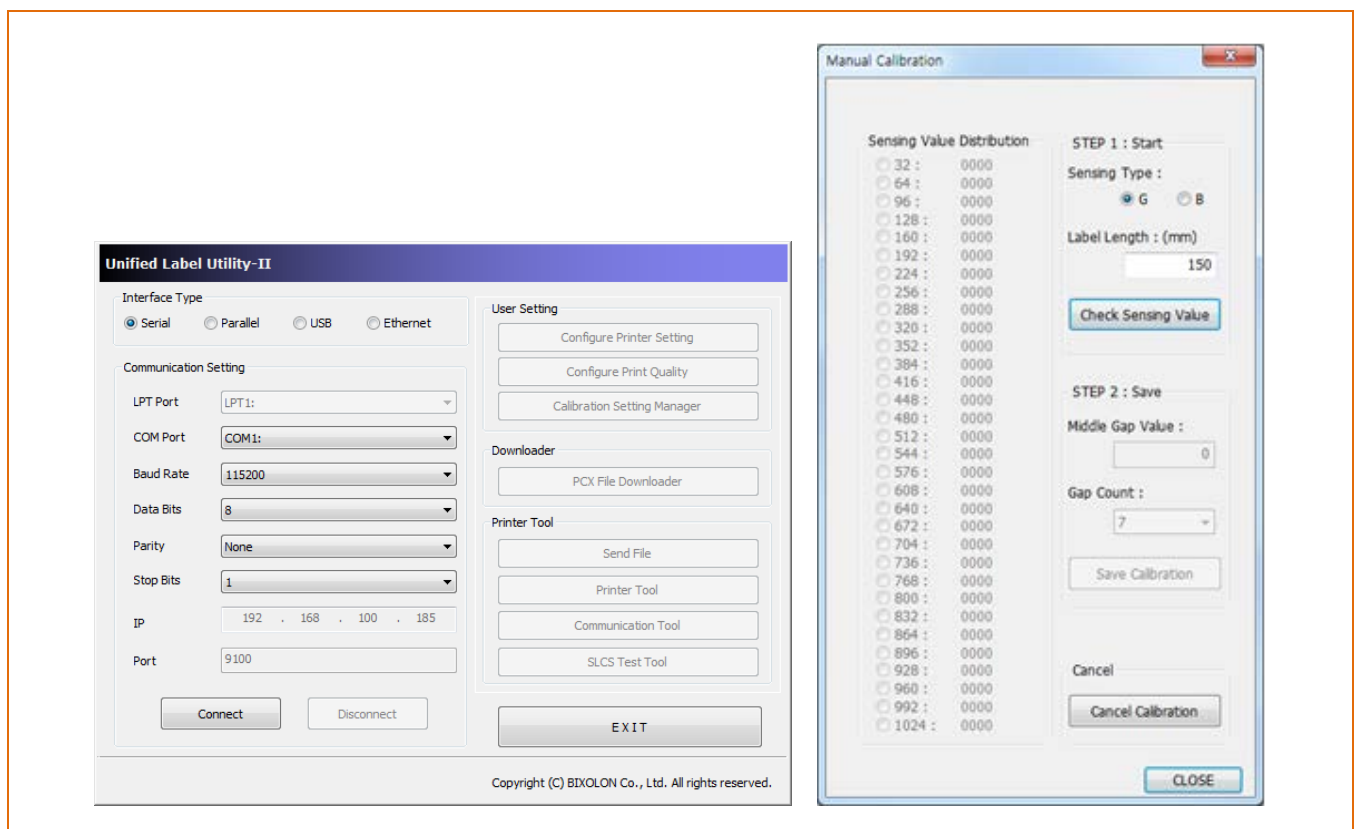

- 1) Select the sensing type and input the label length by millimeter and click "Check Sensing Value" button. Then printer starts calibration.
- 2) Printer will print the scanned values after calibration and the values will appear on the Screen.
- 3) Optimal sensing values will appear in black bold letters on the left of the utility screen and select one of the values and click on "Save Calibration"
- 4) If chosen value does not work properly, please try the other values among the black bold letters.
- 5) To go back to the initial value, please click on "Cancel Calibration"



Caution

Contact the customer center if the printer does not enter media sensor manual-calibration mode.

5-7 Data Dump Mode

- This function can be used to diagnose the communication issues when the printer does not work properly.

In this mode, the received data are not analyzed and printed, instead they are dumped in hex format without processing.

Turn the printer off and on to recover to the print ready mode.

1) Standard Model

Using stand-alone configuration mode, press the Feed/Cancel button () at sequence number 6 data dump mode (refer to 5-1).

2) LCD Model

In print ready mode the setting menu and move to Tools -> Dump -> Dump Enable and press Function button 1 () to run dump mode

* Please refer Tools Menu Explanation (3-6) for more information.



Caution

Contact the customer center if the printer does not enter data dump mode.

5-8 Factory Reset

- This function is used to factory reset the printer settings.

1) Make sure that media roll has been installed properly.

(1) Standard Model

Use Auto Calibration Mode(depends on the media type) for Factory Reset.

* Please refer Tools Menu Explanation (5-1) for more information.

* The printer will be rebooted automatically.

(2) LCD Model

In print ready mode the setting menu and move to Tools -> Reset and press

Function button 1 () to reset the printer to Factory default.

* Please refer Tools Menu Explanation (3-6) for more information.

* The printer will be rebooted automatically.



Caution

Contact the customer center if the printer does not enter factory reset function.

5-9 Print Standby Mode

5-9-1 About Print Standby Mode

The printed area may become out of range of media if the media is not in the accurate printing position when the cover is opened and closed.

The printer is put into print standby mode instead of print ready mode when the cover is closed in order to prevent this problem, and it waits for additional user input.

1) Standard Model

The LED status in the print standby mode can be as follows.

- LED 1: Green Blink
- LED 2: Green Blink

2) LCD Model



The LCD status in the print standby mode can be as follows.

- LCD Display: STANDBY



The data received during print standby mode will be printed after the printer recovers to print ready mode.

5-9-2 How to switch the printer from Standby Mode to Print Ready Mode

1) Standard Model

- Press the Pause button () to switch to print ready mode without feeding any media.
- Press the Feed/Cancel button () to feed one page to align the media position and switch to the print ready mode.

2) LCD Model

- Press "Function button 1 ()" to switch to print ready mode without feeding any media.
- Press "Function button 2 ()" to feed one page to align the media position and switch to the print ready mode.



Caution

Contact the customer center if the printer does not execute print standby mode function.

5-10 Media Installation Method of Peeler (Option) Model

- Use a peeler to separate the printed media from the liner automatically.
To use peeler, install media in the following ways:

- 1) Open the media cover.
- 2) Open the peeler cover.

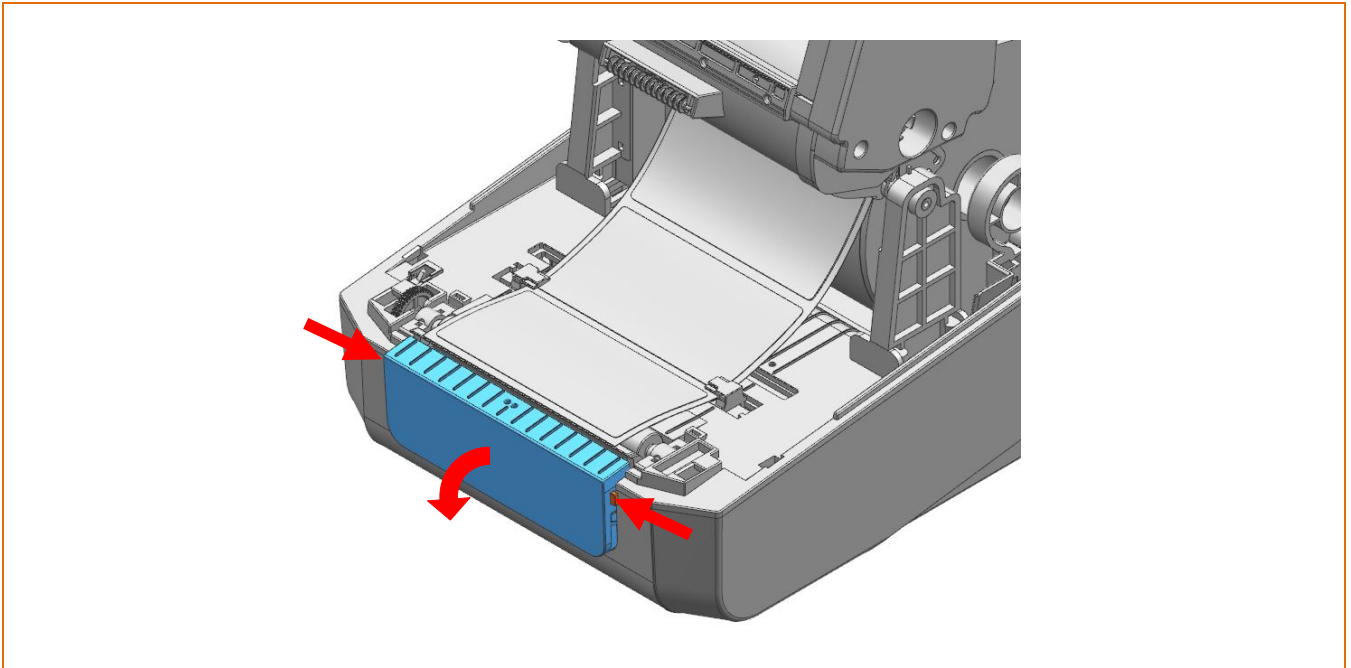

- 3) Set the peeler switch 'ON' position and check to LED has turned on.

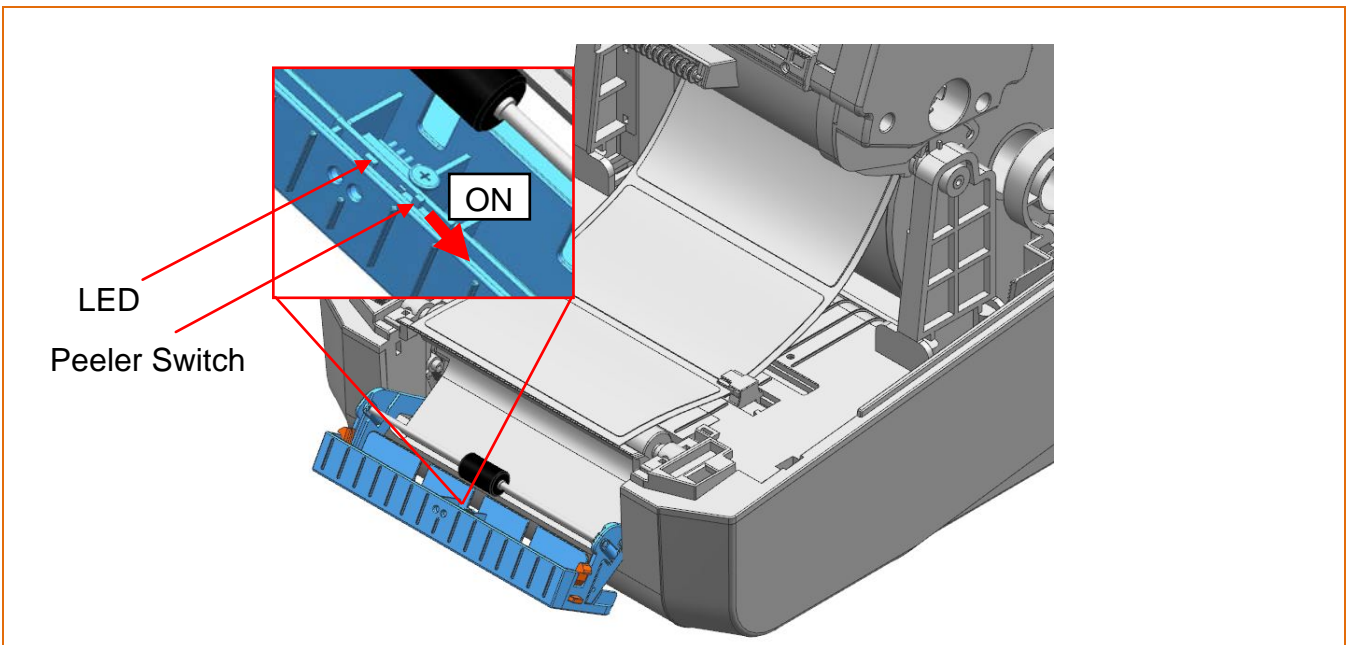

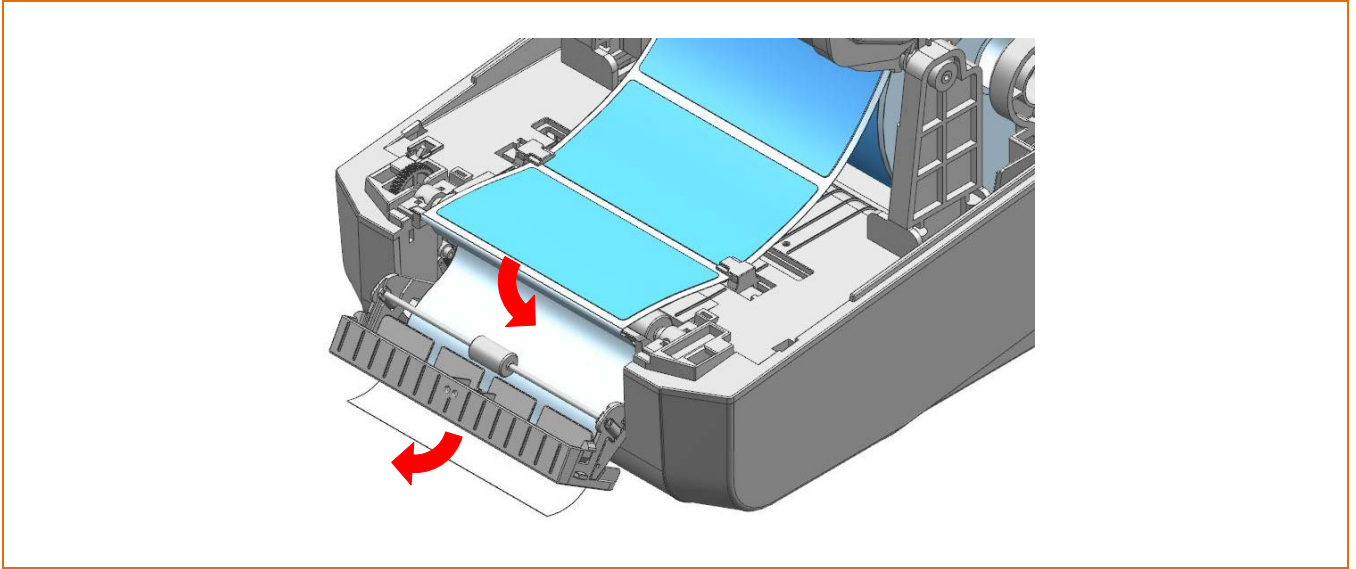

4) Remove the media and insert the media through the slot.

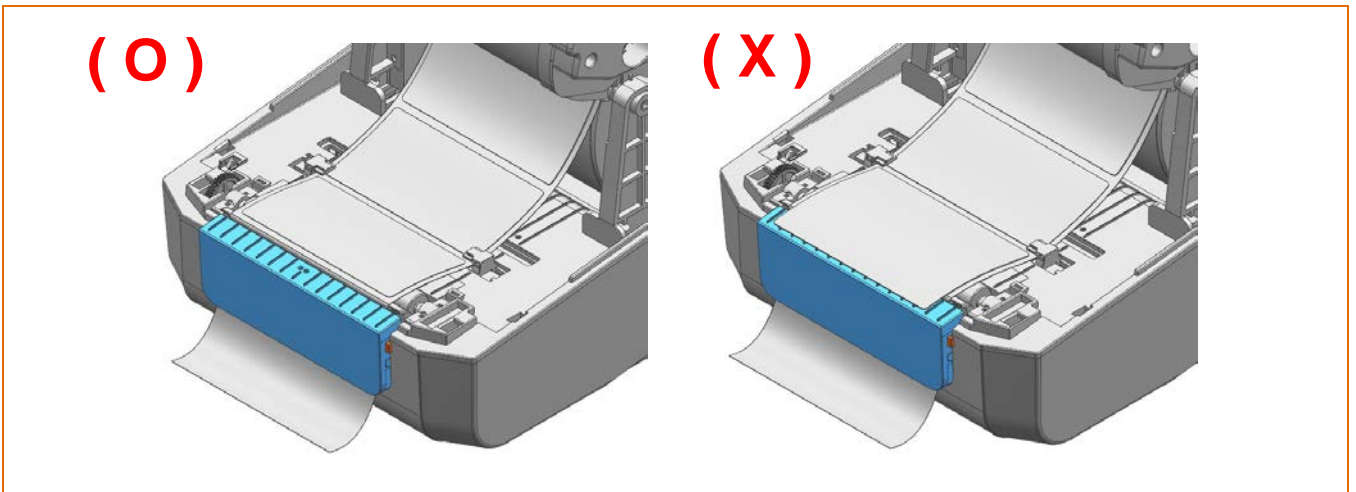

5) Close the peeler cover until a click sound is heard.



6) Close the ribbon assembly and media cover until a click sound is heard.

 Caution	<ul style="list-style-type: none">- When opening or closing the cover, be careful not to pinch your fingers.- The peeler function is only available for Gap media.- When the peeler is switched on, the next label will not be printed unless the printed label is removed from the peeler.- When the peeler is switched off, the peeler does not work.
 Warning	<p>The print head gets extremely hot while printing or after the printing, this can cause serious burns. Do not touch the print head.</p>

5-11 Using Fan-Fold or External Media

- Supplying media to the printer externally is done as follows.
- Remove the rear media supply cover on the back side of the printer with a cutting instrument.

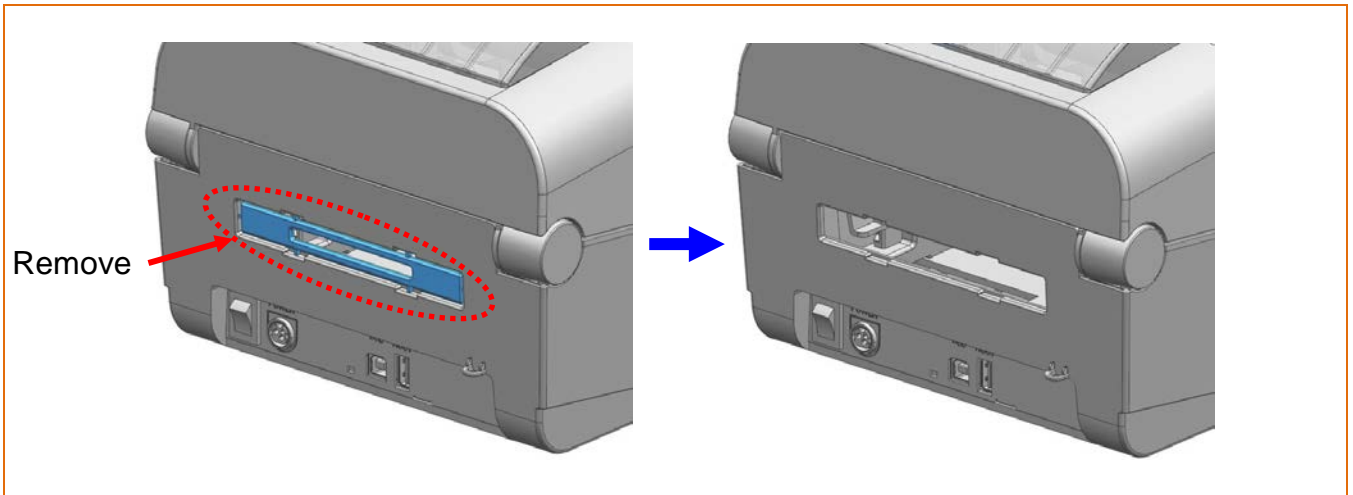

Caution

Take care not to injure the hands and/or any other part of the body when performing this step

5-11-1 When using Fan-Fold media

Supplying fan-fold media to the printer externally is done as follows.

1) Insert the media to at the rear of the printer as shown below.

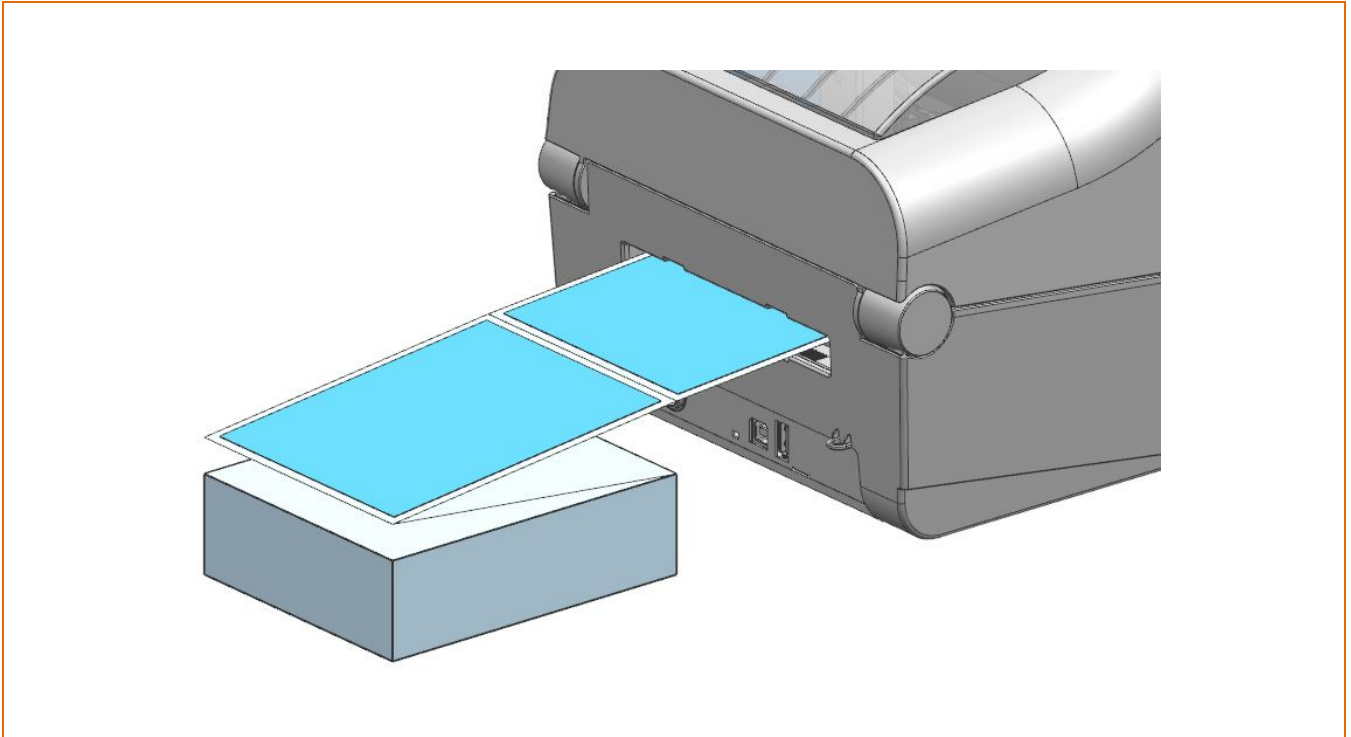

2) Adjust media holders to the media width by using the fix tool.

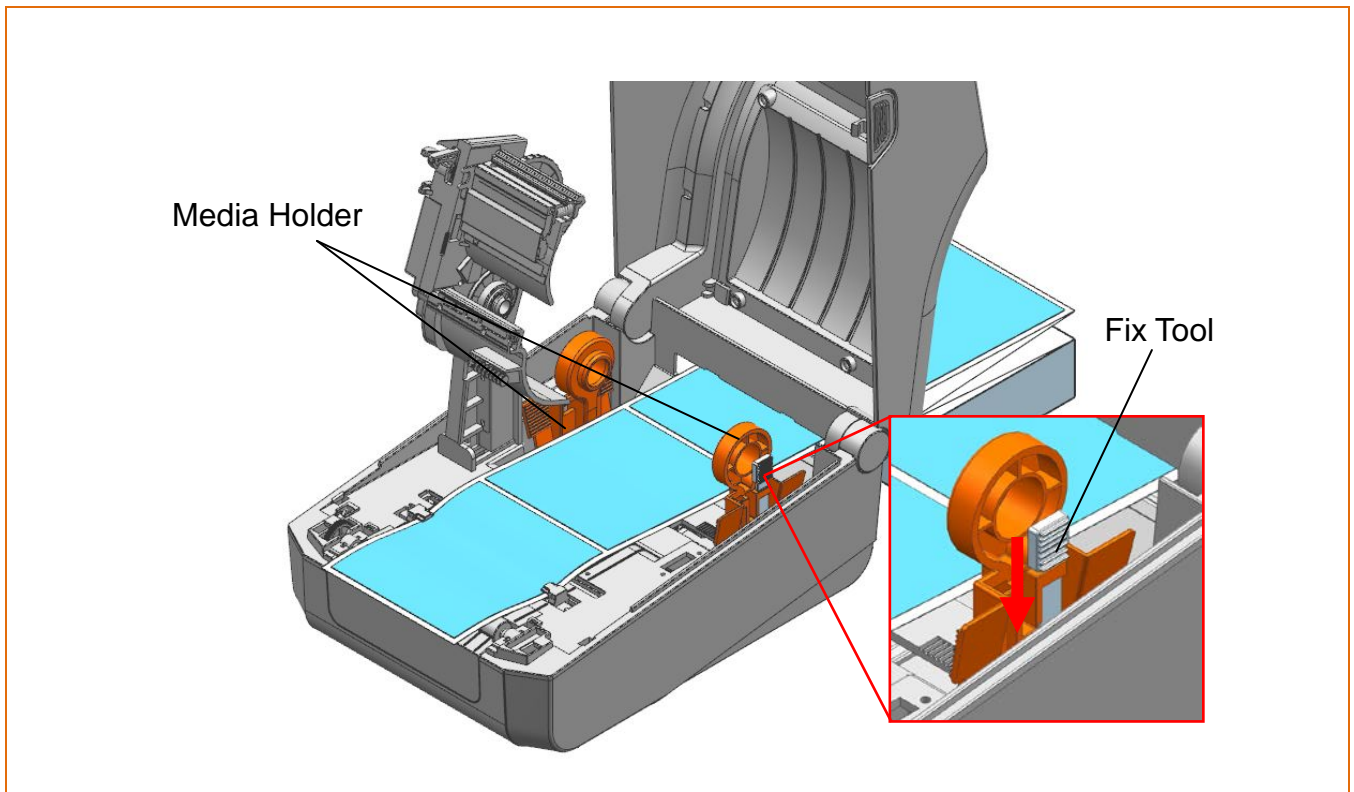

5-11-2 When using Large media roll (Optional)

Install the external media supplier(LES-400G) as shown below and adjust media holders to the media with Fix Tool.

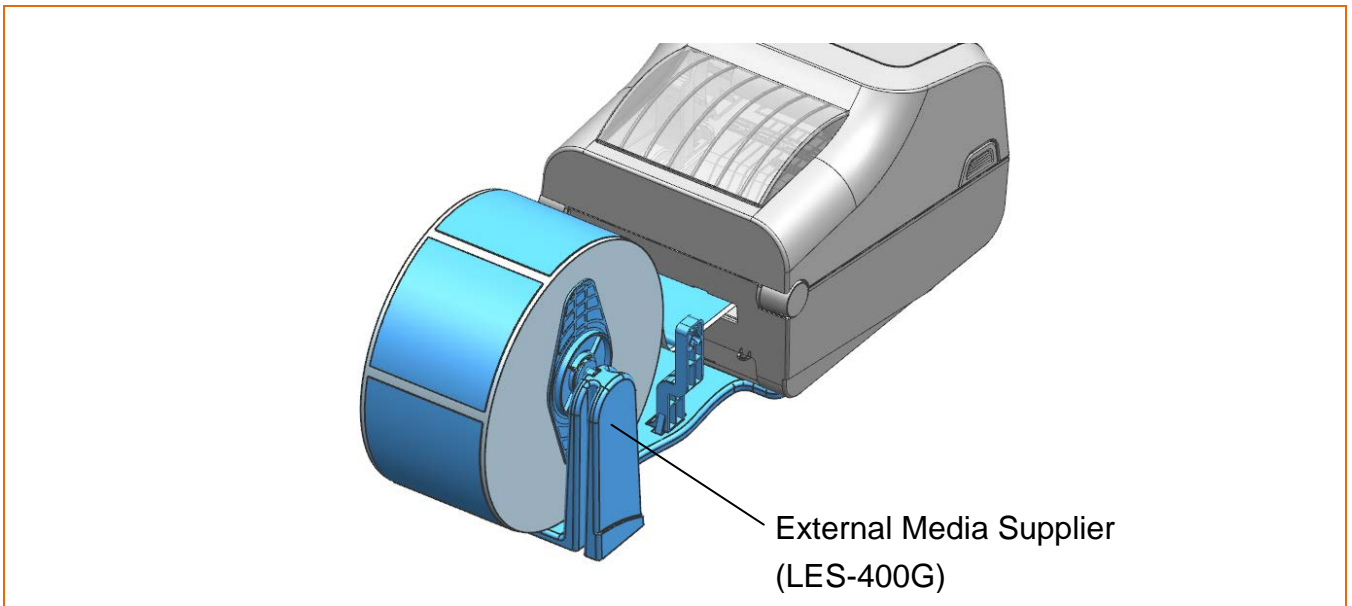

 **Caution**



- Do not open the print cover while the printer is operating, otherwise the printer may be damaged.
- To prevent data loss, replace media only when the printer is not receiving any data.
- Be aware of physical damage caused by external media when operating the printer

5-12 Auto Cutter (Optional)

- For auto media cutting, products equipped with auto cutter are available.

Auto-Cutter can be controlled by command or Unified Label Utility-II.



 Note	Please refer CUT(Auto-cutter Enable/Disable) of Programming (SLCS) Manual or Unified Label Utility-II Manual for more information.
 Caution	<ul style="list-style-type: none">- When opening or closing the cover, be careful not to pinch your fingers.- Do not open the media cover while the printer is operating. The printer may be damaged.- Change the media when the printer is not receiving data, or data may be lost.
 Warning	<ul style="list-style-type: none">- Never insert objects or fingers while performing the cutting function. This can cause serious bodily injury.- Be careful not to touch the cutter blade with your hand. There may be a risk of personal injury.- The print head gets extremely hot while printing or after the printing, this can cause serious burns. Do not touch the print head.

6. Printer Maintenance



Printing quality might be degraded by dust, foreign substance, adhesive substance, or other pollution materials stuck in the printer head or inside the printer.

When dirty, clean the print head as follows

6-1 Cleaning Printer Head

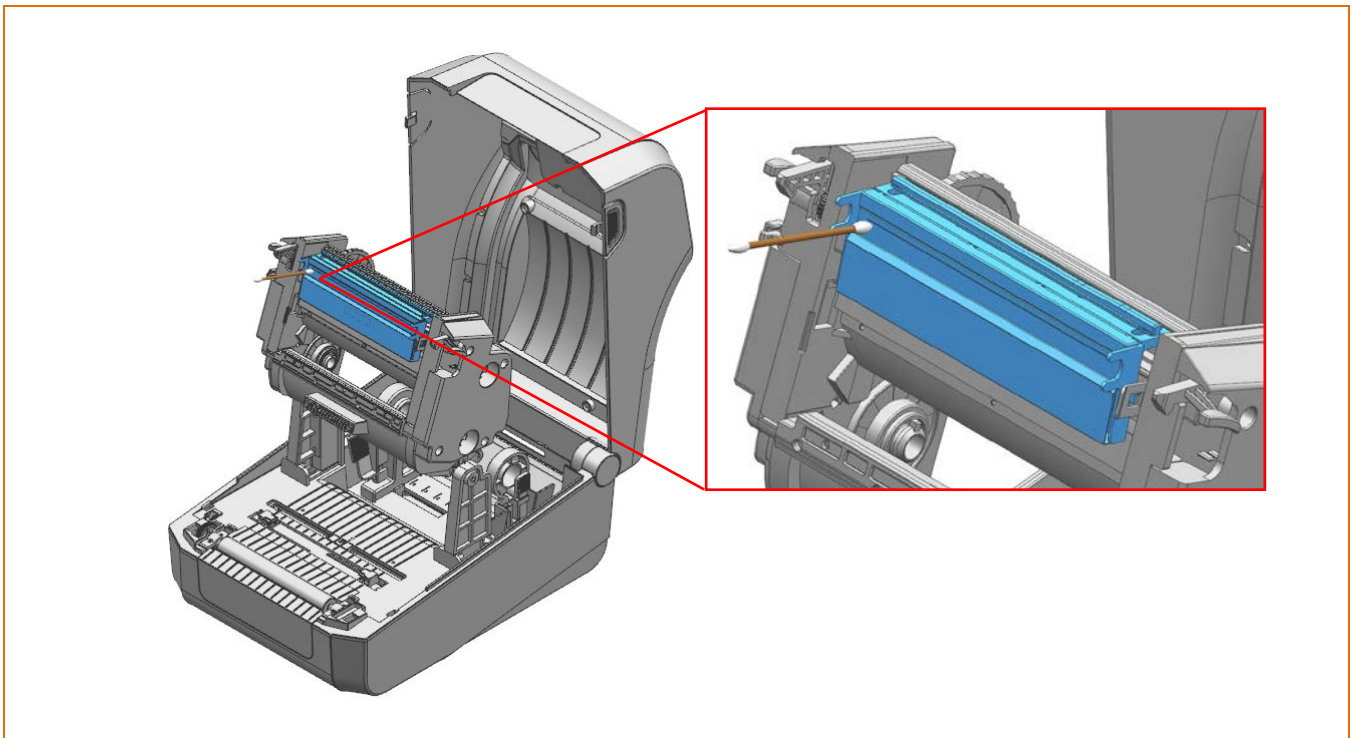
- Be sure to turn the printer off.
- 1) Open the media cover and then remove adhesive foreign substances or other pollution materials with the cloth or cotton swab soaked in alcohol for medical.
 - 2) After cleaning the head, do not use the printer until the alcohol used for cleaning evaporates completely. (1~2 min)



 Note	Perform the cleaning process each time the media roll is replaced to prevent print quality deterioration.
 Caution	<ul style="list-style-type: none"> - Be sure to clean after turning the printer off. - Be careful not to leave scratches in the print head. - The printer may be damaged. - The print head gets extremely hot while printing or after the printing, this can cause serious burns. Do not touch the print head.
 Warning	<p>Do not touch heated area of print-head when cleaning. Personal injury may result from static electricity, etc.</p>

6-2 Cleaning Sensors, Roller or/and media Path

- Be sure to turn the printer off.

- 1) Open the media cover and remove the media.
- 2) Remove any dust or foreign substance using dry cloth or cotton swab.
- 3) Soak the cloth or cotton swab in alcohol for medical use and use it to remove adhesive foreign substances or other pollution materials.

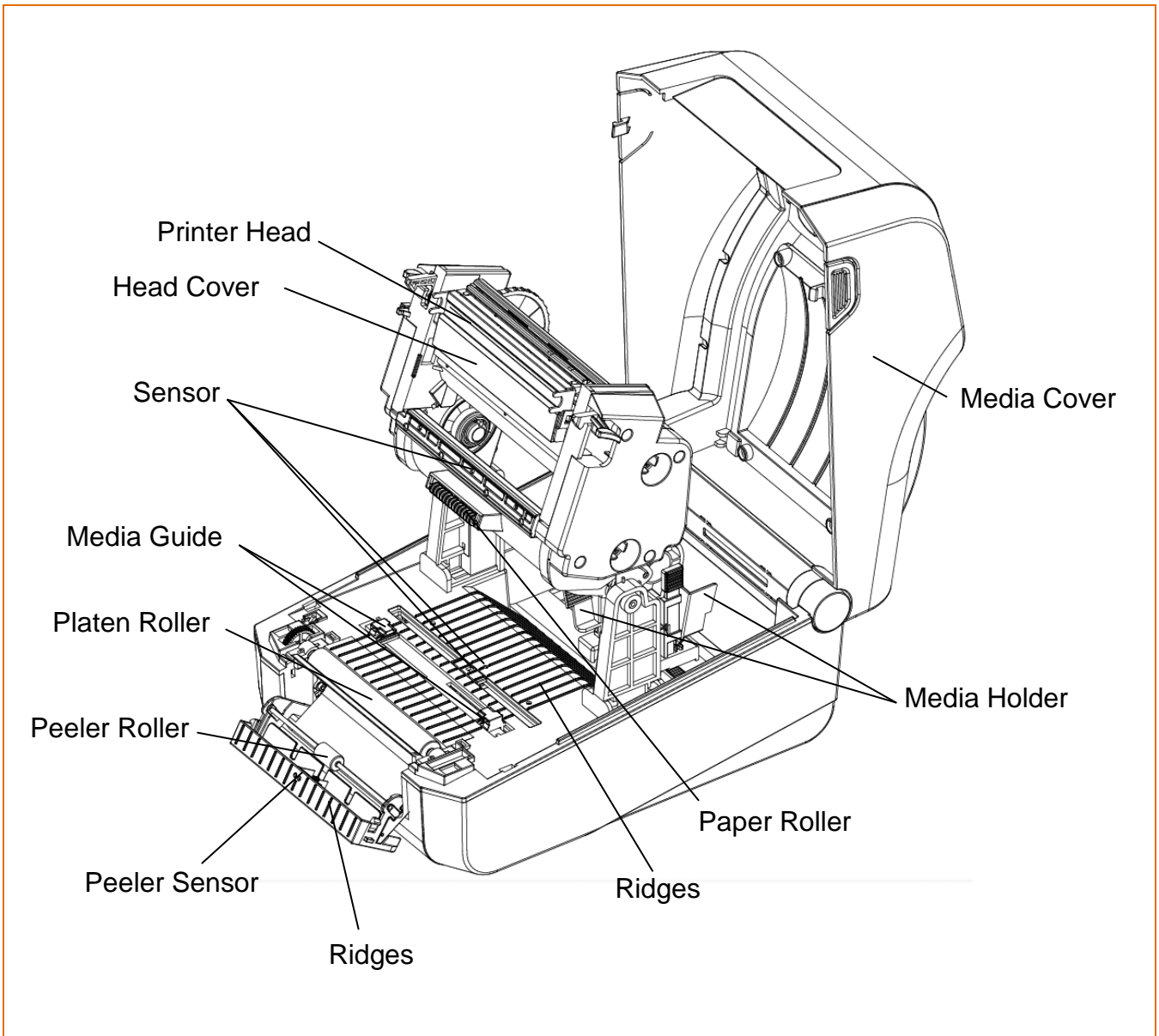

Caution

- Clean the parts when there is a degradation of performance in printing quality or media detection.
- After cleaning the parts, do not use the printer until the alcohol evaporates completely (1~2 min) and the printer has completely dried.
- Be sure to use medical alcohol only. If not, it may cause printer damage.

6-3 Replacing Roller

- Be sure to turn the printer off.

- 1) Open the media cover and remove the media.
- 2) Pull the roller holders and separate the roller assembly.

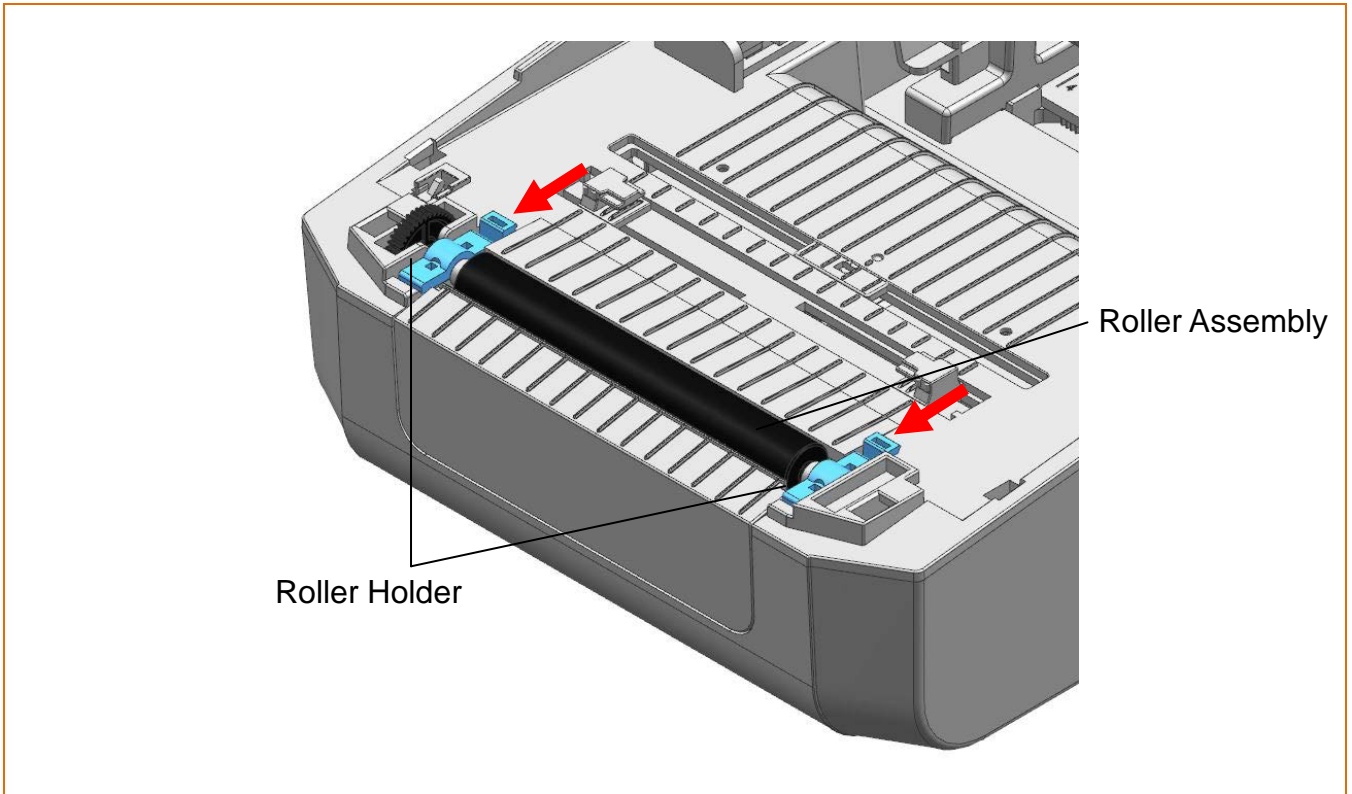

- 3) Assemble new roller assembly in reverse order.



Make sure to turn the printer power off prior to cleaning.



The print head gets extremely hot while printing or after the printing, this can cause serious burns. Do not touch the print head.

7. Appendix

7-1 Specifications

Item	Description	
Printer	Printing Method	Thermal Transfer Printing
	Dot Density	XD5-40t: 203 dpi (8 dot/mm) XD5-43t: 300 dpi (11.8 dot/mm)
	Printing Width	XD5-40t: Max. 108 mm (Max. 4.25") XD5-43t: Max. 105.7 mm (Max. 4.16")
	Printing Speed	XD5-40t: Max. 152 mm/sec (Max. 6ips) XD5-43t: Max. 102 mm/sec (Max. 4ips)
	Printing Length	Up to 1,000mm
Media	Roll Width	15 ~ 118 mm (0.59 ~ 4.64")
	Roll	Max. 127 mm (Max. 5")
	Core	25.4 ~ 38.1 mm (1" ~ 1.5")
	Thickness	0.06 ~ 0.20mm
Ribbon	Length / Width	Max 300m / 33 ~ 110mm(1.3~4.3")
	Type(Outside)	Wax, Wax/Resin, Resin
	Core	0.5" / 1"
AC Adapter	SMPS Input Voltage	AC 100 - 240V
	Frequency	50/60 Hz
	SMPS Output Voltage	DC 24V ±5%
	SMPS Output Current	2.5A
Usage Conditions	Temperature	0 ~ 40 °C (Operating) -20 ~ 60 °C (Storage)
	Humidity (except for media)	10 ~ 80 % RH (Operating) 10 ~ 90 % RH (Storage)



Note

Print speed may vary depending on the data transfer speed and the combination of command.



Caution

- In case of danger, turn off the power to cut the connection.
- The power cord must be grounded to ensure safety and reduce electromagnetic interference

7-2 Label Types

- The label types used with this printer are as follows.
 - Control Labels: PET
 - Other Labels: PET

Copyright

© BIXOLON Co., Ltd. All rights reserved.

This user manual and all property of the product are protected under copyright law. It is strictly prohibited to copy, store, and transmit the whole or any part of the manual and any property of the product without the prior written approval of BIXOLON Co., Ltd. The information contained herein is designed only for use with this BIXOLON product. BIXOLON is not responsible for any direct or indirect damages, arising from or related to use of this information.

- The BIXOLON logo is the registered trademark of BIXOLON Co., Ltd.
- All other brand or product names are trademarks of their respective companies or organizations.

BIXOLON Co., Ltd. maintains ongoing efforts to enhance and upgrade the functions and quality of all our products.

In the following, product specifications and/or user manual content may be changed without prior notice.

Caution

Some semiconductor devices are easily damaged by static electricity. You should turn the printer "OFF", before you connect or remove the cables on the rear side, in order to guard the printer against the static electricity. If the printer is damaged by the static electricity, you should turn the printer "OFF".

Compliance information

This device complies with Part 15 of the FCC Rules. Operation is subject to the following two conditions: (1) This device may not cause harmful interference, and (2) This device must accept any interference received, including interference that may cause undesired operation.

This equipment has been tested and found to comply with the limits for a Class A digital device pursuant to Part 15 of the FCC Rules. These limits are designed to provide reasonable protection against harmful interference when the equipment is operated in a commercial environment. This equipment generates uses, and can radiate radio frequency energy and, if not installed and used in accordance with the instruction manual, may cause harmful interference to radio communications. Operation of this equipment in a residential area is likely to cause harmful interference in which case the user will be required to correct the interference at his own expense.

Caution: Exposure to Radio Frequency Radiation.

To comply with FCC RF exposure compliance requirements, a separation distance of at least 20 cm must be maintained between the antenna of this device and all persons.

Caution: Any Changes or modifications not expressly approved by the manufacturer could void the user's authority to operate the equipment.

Class A Digital Device : Wired Device

This Apparatus complies with class "A" limits for radio interference as specified in the Canadian department of communications radio interference regulations.

This Class A digital apparatus complies with Canadian ICES-003.

Appareil numérique de classe A: appareil filaire

Get appareil est conforme aux normes class "A" d'interference radio tel que specifier par ministre canadien des communications dans les reglements d'interference radio.

Cet appareil numérique de la classe A est conform à la norme NMB-003 du Canada.

Waste Electrical and Electric Equipment (WEEE)



This marking shown on the product or its literature, indicates that is should not be disposed with other household wastes at the end of its working life, To prevent possible harm to the environment or human health from uncontrolled waste disposal, please separate this from other types of wastes and recycle it responsibly to promote the sustainable reuse of material resources. Household users should contact either the retailer where they purchased this product, or their local government office, for details of where and how they can take this item for environmentally safe recycling. Business users should contact their supplier and check the terms and conditions of the purchase contract. This product should not be mixed with other commercial wastes for disposal.

