



EX2300-C and EX2300 Switches Hardware Guide



Modified: 2017-11-09

Juniper Networks, Inc.
1133 Innovation Way
Sunnyvale, California 94089
USA
408-745-2000
www.juniper.net

Juniper Networks, the Juniper Networks logo, Juniper, and Junos are registered trademarks of Juniper Networks, Inc. and/or its affiliates in the United States and other countries. All other trademarks may be property of their respective owners.

Juniper Networks assumes no responsibility for any inaccuracies in this document. Juniper Networks reserves the right to change, modify, transfer, or otherwise revise this publication without notice.

EX2300-C and EX2300 Switches Hardware Guide
Copyright © 2017 Juniper Networks, Inc. All rights reserved.

The information in this document is current as of the date on the title page.

YEAR 2000 NOTICE

Juniper Networks hardware and software products are Year 2000 compliant. Junos OS has no known time-related limitations through the year 2038. However, the NTP application is known to have some difficulty in the year 2036.

END USER LICENSE AGREEMENT

The Juniper Networks product that is the subject of this technical documentation consists of (or is intended for use with) Juniper Networks software. Use of such software is subject to the terms and conditions of the End User License Agreement ("EULA") posted at <http://www.juniper.net/support/eula/>. By downloading, installing or using such software, you agree to the terms and conditions of that EULA.

Table of Contents

	About the Documentation	xvii
	Documentation and Release Notes	xvii
	Supported Platforms	xvii
	Documentation Conventions	xvii
	Documentation Feedback	xix
	Requesting Technical Support	xx
	Self-Help Online Tools and Resources	xx
	Opening a Case with JTAC	xx
Part 1	Overview	
Chapter 1	System Overview	3
	EX2300 Switches Hardware Overview	3
	EX2300 Switches First View	3
	Uplink Ports	4
	Console Ports	4
	Cable Guard	4
	Security Slot	5
	Power over Ethernet (PoE) Ports	5
	Front Panel of an EX2300 Switch	5
	Rear Panel of an EX2300 Switch	8
	EX2300 Switch Models	11
	EX2300 Switch Hardware and CLI Terminology Mapping	13
Chapter 2	Chassis Components and Descriptions	15
	Chassis Physical Specifications for EX2300 Switches	15
	Chassis Status LEDs in EX2300 Switches	16
	Management Port LEDs in EX2300 Switches	20
	RJ-45 Network Port LEDs and Uplink Port LEDs in EX2300 Switches	21
Chapter 3	Cooling System and Airflow	25
	Cooling System and Airflow in an EX2300 Switch	25
	Airflow Direction in EX2300 Switches with 24 Ports with PoE Capability	25
	Airflow Direction in EX2300 Switches with 48 Ports with PoE Capability	26
	Airflow Direction in EX2300 Switches without PoE Capability	27
Chapter 4	Power Supplies	29
	Power Supply in EX2300 Switches	29

Chapter 5	Viewing System Information	31
	Dashboard for EX Series Switches	31
	Graphical Chassis Viewer	32
	System Information Panel	33
	Health Status Panel	35
	Capacity Utilization Panel	37
	Alarms Panel	37
	File System Usage	38
	Chassis Viewer	38
Part 2	Site Planning, Preparation, and Specifications	
Chapter 6	Preparation Overview	53
	Site Preparation Checklist for EX2300 Switches	53
	Environmental Requirements and Specifications for EX Series Switches	55
	General Site Guidelines	59
	Site Electrical Wiring Guidelines	59
	Chassis Physical Specifications for EX2300 Switches	60
	Rack Requirements	61
	Requirements for Mounting an EX2300 Switch On or Under a Desk or Other Level Surface or On a Wall	62
	Cabinet Requirements	63
	Clearance Requirements for Airflow and Hardware Maintenance for EX2300 Switches	64
Chapter 7	Power Specifications and Requirements	69
	Power Specifications for EX2300 Switches	69
	AC Power Cord Specifications for EX2300 Switches	70
	Calculating the EX Series Switch Fiber-Optic Cable Power Budget	72
	Calculating the EX Series Switch Fiber-Optic Cable Power Margin	72
Chapter 8	Transceiver and Cable Specifications	75
	Pluggable Transceivers Supported on EX2300 Switches	75
	Pluggable Transceivers Supported on EX Series Switches	76
	SFP+ Direct Attach Copper Cables for EX Series Switches	80
	Cable Specifications	81
	List of DAC Cables Supported on EX Series Switches	81
	Standards Supported by These Cables	82
	Management Cable Specifications	82
	Understanding EX Series Switches Fiber-Optic Cable Signal Loss, Attenuation, and Dispersion	83
	Signal Loss in Multimode and Single-Mode Fiber-Optic Cable	83
	Attenuation and Dispersion in Fiber-Optic Cable	83
Chapter 9	Pinout Specifications	85
	Console Port Connector Pinout Information	85
	USB Port Specifications for an EX Series Switch	86
	Mini-USB Port Pinout Specifications	87
	RJ-45 Management Port Connector Pinout Information	88

	RJ-45 Port, QSFP+ Port, SFP+ Port, and SFP Port Connector Pinout Information	88
	SFP+ Uplink Port Connector Pinout Information for an EX2300 Switch	93
	RJ-45 to DB-9 Serial Port Adapter Pinout Information	94
Chapter 10	Planning the Virtual Chassis	95
	Planning EX2300 Virtual Chassis	95
	Understanding EX2300 Virtual Chassis Hardware Configuration	96
Part 3	Initial Installation and Configuration	
Chapter 11	Unpacking the Switch	99
	Unpacking an EX2300 Switch	99
	Parts Inventory (Packing List) for an EX2300 Switch	100
	Registering Products—Mandatory for Validating SLAs	101
Chapter 12	Installing the Switch	103
	Installing and Connecting an EX2300 Switch	103
	Mounting an EX2300 Switch	104
	Mounting an EX2300 Switch on a Desk or Other Level Surface	105
	Mounting an EX2300-C Switch Under a Desk or Other Level Surface by Using Screws	107
	Mounting an EX2300 Switch on Two Posts of a Rack or Cabinet	112
	Mounting an EX2300 Switch on Four Posts of a Rack or Cabinet	114
	Mounting an EX2300 Switch on a Wall	118
	Mounting an EX2300-C Switch on a Wall	118
	Mounting an EX2300 Switch Except the EX2300-24MP and EX2300-48MP Models and the EX2300-C Switch on a Wall	122
	Mounting an EX2300-C Switch on or Under a Surface Made of Ferrous Material	126
	Mounting an EX2300 Switch in a Recessed Position in a Rack or Cabinet	131
Chapter 13	Connecting the Switch to Power	133
	Connecting Earth Ground to an EX Series Switch	133
	Parts and Tools Required for Connecting an EX Series Switch to Earth Ground	133
	Special Instructions to Follow Before Connecting Earth Ground to a Switch	137
	Connecting Earth Ground to an EX Series Switch	139
	Connecting AC Power to an EX2300 Switch	140
	Connecting DC Power to an EX2300 Switch	143
Chapter 14	Connecting the Switch to the Network	147
	Connecting a Device to a Network for Out-of-Band Management	147
	Connecting a Device to a Management Console by Using an RJ-45 Connector	148
	Connecting an EX Series Switch to a Management Console by Using the Mini-USB Type-B Console Port	149
	Connecting a Fiber-Optic Cable	151

Chapter 15	Performing Initial Configuration	153
	EX2300 Switch Default Configuration	153
	Connecting and Configuring an EX Series Switch (CLI Procedure)	159
	Connecting and Configuring an EX Series Switch (J-Web Procedure)	162
	Reverting to the Default Factory Configuration for the EX Series Switch	167
	Reverting to the Factory-Default Configuration by Using the LCD Panel	168
	Reverting to the Factory-Default Configuration by Using the request system zeroize Command	168
	Reverting to the Factory-Default Configuration by Using the load factory-default Command	169
	Reverting to the Factory-Default Configuration by Using the Factory Reset/Mode button on EX2300 and EX3400 Switches	170
Part 4	Installing, Maintaining, and Replacing Components	
Chapter 16	Replacing Transceiver	175
	Installing a Transceiver	175
	Removing a Transceiver	177
Chapter 17	Maintaining and Replacing Fiber-Optic Cable	181
	Connecting a Fiber-Optic Cable	181
	Disconnecting a Fiber-Optic Cable from a Device	182
	Maintaining Fiber-Optic Cables	183
Chapter 18	Contacting Customer Support and Returning the Chassis or Components	185
	Returning an EX2300 Switch or Component for Repair or Replacement	185
	Locating the Serial Number on an EX2300 Switch or Component	186
	Listing the Switch and Components Details with the CLI	186
	Locating the Chassis Serial Number ID Label on an EX2300 Switch	187
	Contacting Customer Support to Obtain Return Material Authorization	187
	Packing an EX2300 Switch or Component for Shipping	188
	Packing a Switch for Shipping	189
	Packing Switch Components for Shipping	190
Part 5	Troubleshooting	
Chapter 19	Alarms and System Log Messages	193
	Understanding Alarm Types and Severity Levels on EX Series Switches	193
	Chassis Component Alarm Conditions on EX2300 Switches	194
	Checking Active Alarms with the J-Web Interface	196
	Monitoring System Log Messages	197
Chapter 20	Troubleshooting Switch Components	203
	Troubleshooting PoE Voltage Injection Failure in EX2300, EX3400, or EX4300 Switch Models with PoE Capability	203
	Troubleshooting Storage Issues While Upgrading Junos OS in EX2300 and EX3400 Switches	203
	Troubleshooting Temperature Alarms in EX Series Switches	205

Part 6	Safety and Compliance Information	
Chapter 21	General Safety Guidelines and Warnings	213
	General Safety Guidelines and Warnings	213
	Definitions of Safety Warning Levels	214
	Qualified Personnel Warning	216
	Warning Statement for Norway and Sweden	217
Chapter 22	Fire Safety Requirements	219
	Fire Safety Requirements	219
	Fire Suppression	219
	Fire Suppression Equipment	219
Chapter 23	Installation Safety Guidelines and Warnings	221
	Installation Instructions Warning	221
	Chassis Lifting Guidelines	222
	Restricted Access Warning	222
	Ramp Warning	224
	Rack-Mounting and Cabinet-Mounting Warnings	224
	Wall-Mounting Warnings for EX2300 Switches	228
	Grounded Equipment Warning	228
Chapter 24	Radiation and Laser Safety Guidelines and Warnings	231
	Laser and LED Safety Guidelines and Warnings	231
	General Laser Safety Guidelines	231
	Class 1 Laser Product Warning	232
	Class 1 LED Product Warning	232
	Laser Beam Warning	232
	Radiation from Open Port Apertures Warning	233
Chapter 25	Maintenance and Operational Safety Warnings	235
	Maintenance and Operational Safety Guidelines and Warnings	235
	Battery Handling Warning	235
	Jewelry Removal Warning	236
	Lightning Activity Warning	237
	Operating Temperature Warning	238
	Product Disposal Warning	239
Chapter 26	Electrical Safety Guidelines and Warnings	241
	General Electrical Safety Guidelines and Warnings	241
	Action to Take After an Electrical Accident	242
	Prevention of Electrostatic Discharge Damage	243
	AC Power Electrical Safety Guidelines	244
	AC Power Disconnection Warning	245
	DC Power Electrical Safety Guidelines for Switches	246
	DC Power Disconnection Warning	249
	DC Power Grounding Requirements and Warning	250
	DC Power Wiring Sequence Warning	251
	DC Power Wiring Terminations Warning	253
	Multiple Power Supplies Disconnection Warning	254
	TN Power Warning	254

Chapter 27	Agency Approvals and Compliance Statements	257
	Agency Approvals for EX Series Switches	257
	Compliance Statements for EMC Requirements for EX Series Switches	258
	Canada	258
	European Community	259
	Israel	259
	Japan	259
	Korea	260
	United States	260
	FCC Part 15 Statement	260
	Nonregulatory Environmental Standards	261
	Compliance Statements for Acoustic Noise for EX Series Switches	262

List of Figures

Part 1	Overview	
Chapter 1	System Overview	3
	Figure 1: Front Panel of an EX2300-C Switch with 12 Gigabit Ethernet Ports with PoE Capability	6
	Figure 2: Front Panel of an EX2300-C Switch with 12 Gigabit Ethernet Ports without PoE Capability	6
	Figure 3: Front Panel of an EX2300 Switch with 24 Gigabit Ethernet Ports with PoE Capability	7
	Figure 4: Front Panel of an EX2300 Switch with 48 Gigabit Ethernet Ports with PoE Capability	8
	Figure 5: Rear Panel of an EX2300-C Switch with 12 Gigabit Ethernet Ports with PoE Capability	8
	Figure 6: Rear Panel of an EX2300-C Switch with 12 Gigabit Ethernet Ports without PoE Capability	9
	Figure 7: Rear Panel of an AC-Powered EX2300 Switch with 24 Gigabit Ethernet Ports with PoE Capability	10
	Figure 8: Rear Panel of an AC-Powered EX2300 Switch with 24 Gigabit Ethernet Ports without PoE Capability	10
	Figure 9: Rear Panel of a DC-Powered EX2300 Switch with 24 Gigabit Ethernet Ports	10
	Figure 10: Rear Panel of an AC-Powered EX2300 Switch with 48 Gigabit Ethernet Ports with PoE Capability	11
	Figure 11: Rear Panel of an AC-Powered EX2300 Switch with 48 Gigabit Ethernet Ports without PoE Capability	11
Chapter 2	Chassis Components and Descriptions	15
	Figure 12: Chassis Status LEDs in EX2300-C Switches	16
	Figure 13: Chassis Status LEDs in EX2300 Switches Except the EX2300-C, EX2300-24MP and EX2300-48MP Models	17
	Figure 14: Chassis Status LEDs in EX2300-24MP and EX2300-48MP Models	18
	Figure 15: LEDs on the Management Port on EX2300-C Switches	20
	Figure 16: LEDs on the Management Port on EX2300 Switches Except EX2300-24MP and EX2300-48MP Models	20
	Figure 17: LEDs on RJ-45 Network Ports	21
	Figure 18: LEDs on the Uplink Ports in EX2300-C Switches	21
	Figure 19: LEDs on the Uplink Ports in an EX2300 Switches Except the EX2300-C Switches	22
	Figure 20: Port Mode LEDs on EX2300 Switches	22
Chapter 3	Cooling System and Airflow	25

	Figure 21: Airflow Direction in EX2300 Switches with 24 Ports with PoE Capability	26
	Figure 22: Airflow Direction in EX2300 Switches with 48 Ports with PoE Capability	27
	Figure 23: Airflow Direction in EX2300 Switches with 24 Ports without PoE Capability	28
Part 2	Site Planning, Preparation, and Specifications	
Chapter 6	Preparation Overview	53
	Figure 24: Clearance Requirements for Airflow and Hardware Maintenance for EX2300-C Switches	64
	Figure 25: Clearance Requirements for Airflow and Hardware Maintenance for EX2300 Switches Except EX2200-C Switches	65
	Figure 26: Airflow Direction in EX2300 Switches with 24 Ports with PoE Capability	66
	Figure 27: Airflow Direction in EX2300 Switches with 48 Ports with PoE Capability	66
	Figure 28: Airflow Direction in EX2300 Switches without PoE Capability	67
Chapter 7	Power Specifications and Requirements	69
	Figure 29: AC Plug Types	71
Chapter 8	Transceiver and Cable Specifications	75
	Figure 30: SFP+ Direct Attach Copper Cables for EX Series Switches	81
Part 3	Initial Installation and Configuration	
Chapter 12	Installing the Switch	103
	Figure 31: Attaching a Cable Guard to an EX2300-C Switch	106
	Figure 32: Securing the EX2300-C Switch by Using the Security Slot	107
	Figure 33: Attaching a Cable Guard to an EX2300-C Switch	109
	Figure 34: Measurements for Installing Mounting Screws for Mounting EX2300-C Switches Under a Desk or Other Level Surface by Using Screws	110
	Figure 35: Mounting the EX2300-C Switch Under a Desk or Other Level Surface by Using Screws	111
	Figure 36: Securing the EX2300-C Switch by Using the Security Slot	111
	Figure 37: Attaching the Mounting Bracket Along the Front of the Switch	113
	Figure 38: Mounting the Switch on Two Posts of a Rack	114
	Figure 39: Attaching the Front-Mounting Bracket to the Side Mounting-Rail	116
	Figure 40: Attaching the Side Mounting-Rail to the Switch Chassis	116
	Figure 41: Mounting the Switch to the Front Posts of a Rack	117
	Figure 42: Sliding the Rear Mounting-Blades into the Side Mounting-Rail	117
	Figure 43: Attaching a Cable Guard to an EX2300-C Switch	119
	Figure 44: Measurements for Installing Mounting Screws for Mounting an EX2300-C Switch on a Wall	120
	Figure 45: Mounting an EX2300-C Switch on a Wall	121
	Figure 46: Securing the EX2300-C Switch by Using the Security Slot	121
	Figure 47: Attaching Wall-Mount Brackets to an EX2300 Switch Except the EX2300-24MP and EX2300-48MP Models and the EX2300-C Switch	123

	Figure 48: Measurements for Installing Mounting Screws to Mount an EX2300 Switch Except the EX2300-24MP and EX2300-48MP Models and the EX2300-C Switch on a Wall	125
	Figure 49: Mounting an EX2300 Switch Except the EX2300-24MP and EX2300-48MP Models and the EX2300-C Switch on a Wall	126
	Figure 50: Attaching a Cable Guard to an EX2300-C Switch	128
	Figure 51: Attaching Rubber Pads to an EX2300-C Switch	128
	Figure 52: Attaching the Magnet Mount Sheet to an EX2300-C Switch	129
	Figure 53: Mounting an EX2300-C Switch on or Under a Surface Made of Ferrous Material	130
	Figure 54: Securing the EX2300-C Switch by Using the Security Slot	130
Chapter 13	Connecting the Switch to Power	133
	Figure 55: Connecting the Grounding Lug to a Switch Mounted on Four Posts of a Rack	138
	Figure 56: Connecting a Grounding Cable to an EX Series Switch	139
	Figure 57: Connecting an AC Power Cord Retainer Clip to the AC Power Cord Inlet on EX2300-C Switches	142
	Figure 58: Connecting an AC Power Cord Retainer Clip to the AC Power Cord Inlet on EX2300 Switches Except the EX2300-C, EX2300-24MP, and EX2300-48MP Models	142
	Figure 59: Connecting an AC Power Cord to the AC Power Cord Inlet on EX2300-C Switches	142
	Figure 60: Connecting an AC Power Cord to the AC Power Cord Inlet on EX2300 Switches Except EX2300-C Switches	142
	Figure 61: Securing the Ring Lugs On the Power Cables to the Terminals on the DC Power Supply	144
Chapter 14	Connecting the Switch to the Network	147
	Figure 62: RJ-45 Connector on an Ethernet Cable	147
	Figure 63: Connecting a Device to a Network for Out-of-Band Management	148
	Figure 64: RJ-45 Connector on an Ethernet Cable	148
	Figure 65: Connecting a Device to a Management Console Through a Console Server	149
	Figure 66: Connecting a Device Directly to a Management Console	149
	Figure 67: Connecting a Fiber-Optic Cable to an Optical Transceiver Installed in a Device	151
Chapter 15	Performing Initial Configuration	153
	Figure 68: LCD Panel in an EX3200, EX4200, EX4500, EX4550, or EX8200 Switch	164
	Figure 69: LCD Panel in an EX4300 Switch	164
	Figure 70: EX Series Switch LCD Panel	168
Part 4	Installing, Maintaining, and Replacing Components	
Chapter 16	Replacing Transceiver	175
	Figure 71: Installing a Transceiver	177
	Figure 72: Removing an SFP, SFP+, XFP, or a QSFP+ Transceiver	179
Chapter 17	Maintaining and Replacing Fiber-Optic Cable	181

	Figure 73: Connecting a Fiber-Optic Cable to an Optical Transceiver Installed in a Device	182
Chapter 18	Contacting Customer Support and Returning the Chassis or Components	185
	Figure 74: Location of the Serial Number ID Label on EX2300-C Switches	187
	Figure 75: Location of the Serial Number ID Label on EX2300 Switches Except EX2300-C Switches	187
Part 6	Safety and Compliance Information	
Chapter 26	Electrical Safety Guidelines and Warnings	241
	Figure 76: Placing a Component into an Antistatic Bag	244

List of Tables

	About the Documentation	xvii
	Table 1: Notice Icons	xviii
	Table 2: Text and Syntax Conventions	xviii
Part 1	Overview	
Chapter 1	System Overview	3
	Table 3: EX2300 Switch Models	12
	Table 4: CLI Equivalents of Terms Used in Documentation for EX2300 Switches	13
Chapter 2	Chassis Components and Descriptions	15
	Table 5: Physical Specifications of the EX2300 Switch Chassis	15
	Table 6: Chassis Status LEDs in EX2300 Switches Except the EX2300-24MP and EX2300-48 MP Models	17
	Table 7: Chassis Status LEDs in EX2300-24MP and EX2300-48 MP Models	19
	Table 8: Link/Activity LED on the Management Port on EX2300 Switches	21
	Table 9: Status LED on the Management Port on EX2300 Switches	21
	Table 10: Link/Activity LED on the RJ-45 Network Ports and the Uplink Ports in EX2300 Switches	22
	Table 11: Status LED on the RJ-45 Network Ports in EX2300 Switches	23
	Table 12: Status LED on the Uplink Ports in EX2300 Switches	23
Chapter 4	Power Supplies	29
	Table 13: Power Consumed by EX2300 Switches	29
Chapter 5	Viewing System Information	31
	Table 14: Details of a Virtual Chassis Member Switch	32
	Table 15: Status of a Member Switch in a Virtual Chassis	33
	Table 16: System Information	33
	Table 17: Health Status	35
	Table 18: Capacity Utilization	37
	Table 19: Chassis Viewer for EX2200 Switches	38
	Table 20: Chassis Viewer for EX2200-C Switches	39
	Table 21: Chassis Viewer for EX3200, EX3300, and EX4200 Switches	39
	Table 22: Chassis Viewer for EX4300 Switches	41
	Table 23: Chassis Viewer for EX4500 Switches	42
	Table 24: Chassis Viewer for EX4550 Switches	43
	Table 25: Chassis Viewer for EX4600 Switches	45
	Table 26: Chassis Viewer for EX6210 Switches	45
	Table 27: Chassis Viewer for EX8208 Switches	46
	Table 28: Chassis Viewer for EX8216 Switches	48

	Table 29: Chassis Viewer for XRE200 External Routing Engines	48
Part 2	Site Planning, Preparation, and Specifications	
Chapter 6	Preparation Overview	53
	Table 30: Site Preparation Checklist	53
	Table 31: EX Series Switch Environmental Tolerances	55
	Table 32: Site Electrical Wiring Guidelines	60
	Table 33: Physical Specifications of the EX2300 Switch Chassis	60
	Table 34: Rack Requirements and Specifications	62
	Table 35: Cabinet Requirements and Specifications	63
Chapter 7	Power Specifications and Requirements	69
	Table 36: AC Power Supply Electrical Specifications for EX2300 Switches	69
	Table 37: DC Power Supply Electrical Specifications for EX2300 Switches (Except EX2300-C, EX2300-24MP, and EX2300-48MP Switches)	70
	Table 38: AC Power Cord Specifications	71
	Table 39: Estimated Values for Factors Causing Link Loss	73
Chapter 8	Transceiver and Cable Specifications	75
	Table 40: Specifications of Cables to Connect to Management Devices	82
Chapter 9	Pinout Specifications	85
	Table 41: Console Port Connector Pinout Information	85
	Table 42: Mini-USB Type-B Console Port Pinout Information	87
	Table 43: RJ-45 Management Port Connector Pinout Information	88
	Table 44: 10/100/1000BASE-T Ethernet Network Port Connector Pinout Information	88
	Table 45: SFP Network Port Connector Pinout Information	89
	Table 46: SFP+ Network Port Connector Pinout Information	90
	Table 47: QSFP+ Network Port Connector Pinout Information	91
	Table 48: Connector Pinout Information for the 10-Gigabit Ethernet Uplink Port	93
	Table 49: RJ-45 to DB-9 Serial Port Adapter Pinout Information	94
Part 3	Initial Installation and Configuration	
Chapter 11	Unpacking the Switch	99
	Table 50: Parts List for EX2300 Switches	100
Chapter 12	Installing the Switch	103
	Table 51: EX2300 Switch Mounting Methods	104
Chapter 13	Connecting the Switch to Power	133
	Table 52: Parts and Tools Required for Connecting an EX Series Switch to Earth Ground	134
	Table 53: Special Instructions to Follow Before Connecting Earth Ground to a Switch	137
Part 5	Troubleshooting	
Chapter 19	Alarms and System Log Messages	193

	Table 54: Alarm Terms	193
	Table 55: Alarm Conditions on EX2300 Switches	195
	Table 56: Summary of Key Alarm Output Fields	197
	Table 57: Filtering System Log Messages	198
	Table 58: Viewing System Log Messages	200
Chapter 20	Troubleshooting Switch Components	203
	Table 59: show chassis environment Output Fields	206
	Table 60: show chassis temperature-thresholds Output Fields	207
	Table 61: Causes and Remedies for Temperature Alarms	208

About the Documentation

- Documentation and Release Notes on page xvii
- Supported Platforms on page xvii
- Documentation Conventions on page xvii
- Documentation Feedback on page xix
- Requesting Technical Support on page xx

Documentation and Release Notes

To obtain the most current version of all Juniper Networks® technical documentation, see the product documentation page on the Juniper Networks website at <http://www.juniper.net/techpubs/>.

If the information in the latest release notes differs from the information in the documentation, follow the product Release Notes.

Juniper Networks Books publishes books by Juniper Networks engineers and subject matter experts. These books go beyond the technical documentation to explore the nuances of network architecture, deployment, and administration. The current list can be viewed at <http://www.juniper.net/books>.

Supported Platforms

For the features described in this document, the following platforms are supported:

- EX2300

Documentation Conventions

Table 1 on page xviii defines notice icons used in this guide.

Table 1: Notice Icons







Icon	Meaning	Description
	Informational note	Indicates important features or instructions.
	Caution	Indicates a situation that might result in loss of data or hardware damage.
	Warning	Alerts you to the risk of personal injury or death.
	Laser warning	Alerts you to the risk of personal injury from a laser.
	Tip	Indicates helpful information.
	Best practice	Alerts you to a recommended use or implementation.

Table 2 on page xviii defines the text and syntax conventions used in this guide.

Table 2: Text and Syntax Conventions

Convention	Description	Examples
Bold text like this	Represents text that you type.	To enter configuration mode, type the configure command: user@host> configure
Fixed-width text like this	Represents output that appears on the terminal screen.	user@host> show chassis alarms No alarms currently active
<i>Italic text like this</i>	<ul style="list-style-type: none"> Introduces or emphasizes important new terms. Identifies guide names. Identifies RFC and Internet draft titles. 	<ul style="list-style-type: none"> A policy <i>term</i> is a named structure that defines match conditions and actions. <i>Junos OS CLI User Guide</i> RFC 1997, <i>BGP Communities Attribute</i>
<i>Italic text like this</i>	Represents variables (options for which you substitute a value) in commands or configuration statements.	Configure the machine's domain name: [edit] root@# set system domain-name <i>domain-name</i>

Table 2: Text and Syntax Conventions (*continued*)

Convention	Description	Examples
Text like this	Represents names of configuration statements, commands, files, and directories; configuration hierarchy levels; or labels on routing platform components.	<ul style="list-style-type: none"> To configure a stub area, include the stub statement at the [edit protocols ospf area area-id] hierarchy level. The console port is labeled CONSOLE.
< > (angle brackets)	Encloses optional keywords or variables.	stub <default-metric metric>;
(pipe symbol)	Indicates a choice between the mutually exclusive keywords or variables on either side of the symbol. The set of choices is often enclosed in parentheses for clarity.	broadcast multicast (string1 string2 string3)
# (pound sign)	Indicates a comment specified on the same line as the configuration statement to which it applies.	rsvp { # Required for dynamic MPLS only
[] (square brackets)	Encloses a variable for which you can substitute one or more values.	community name members [community-ids]
Indentation and braces ({ })	Identifies a level in the configuration hierarchy.	[edit] routing-options { static { route default { nexthop address; retain; } } }
;(semicolon)	Identifies a leaf statement at a configuration hierarchy level.	
GUI Conventions		
Bold text like this	Represents graphical user interface (GUI) items you click or select.	<ul style="list-style-type: none"> In the Logical Interfaces box, select All Interfaces. To cancel the configuration, click Cancel.
> (bold right angle bracket)	Separates levels in a hierarchy of menu selections.	In the configuration editor hierarchy, select Protocols>Ospf .

Documentation Feedback

We encourage you to provide feedback, comments, and suggestions so that we can improve the documentation. You can provide feedback by using either of the following methods:

- Online feedback rating system—On any page of the Juniper Networks TechLibrary site at <http://www.juniper.net/techpubs/index.html>, simply click the stars to rate the content, and use the pop-up form to provide us with information about your experience. Alternately, you can use the online feedback form at <http://www.juniper.net/techpubs/feedback/>.

- E-mail—Send your comments to techpubs-comments@juniper.net. Include the document or topic name, URL or page number, and software version (if applicable).

Requesting Technical Support

Technical product support is available through the Juniper Networks Technical Assistance Center (JTAC). If you are a customer with an active J-Care or Partner Support Service support contract, or are covered under warranty, and need post-sales technical support, you can access our tools and resources online or open a case with JTAC.

- JTAC policies—For a complete understanding of our JTAC procedures and policies, review the *JTAC User Guide* located at <http://www.juniper.net/us/en/local/pdf/resource-guides/7100059-en.pdf>.
- Product warranties—For product warranty information, visit <http://www.juniper.net/support/warranty/>.
- JTAC hours of operation—The JTAC centers have resources available 24 hours a day, 7 days a week, 365 days a year.

Self-Help Online Tools and Resources

For quick and easy problem resolution, Juniper Networks has designed an online self-service portal called the Customer Support Center (CSC) that provides you with the following features:

- Find CSC offerings: <http://www.juniper.net/customers/support/>
- Search for known bugs: <https://prsearch.juniper.net/>
- Find product documentation: <http://www.juniper.net/documentation/>
- Find solutions and answer questions using our Knowledge Base: <http://kb.juniper.net/>
- Download the latest versions of software and review release notes: <http://www.juniper.net/customers/csc/software/>
- Search technical bulletins for relevant hardware and software notifications: <http://kb.juniper.net/InfoCenter/>
- Join and participate in the Juniper Networks Community Forum: <http://www.juniper.net/company/communities/>
- Open a case online in the CSC Case Management tool: <http://www.juniper.net/cm/>

To verify service entitlement by product serial number, use our Serial Number Entitlement (SNE) Tool: <https://entitlementsearch.juniper.net/entitlementsearch/>

Opening a Case with JTAC

You can open a case with JTAC on the Web or by telephone.

- Use the Case Management tool in the CSC at <http://www.juniper.net/cm/>.
- Call 1-888-314-JTAC (1-888-314-5822 toll-free in the USA, Canada, and Mexico).

For international or direct-dial options in countries without toll-free numbers, see <http://www.juniper.net/support/requesting-support.html>.

PART 1

Overview

- [System Overview on page 3](#)
- [Chassis Components and Descriptions on page 15](#)
- [Cooling System and Airflow on page 25](#)
- [Power Supplies on page 29](#)
- [Viewing System Information on page 31](#)

CHAPTER 1

System Overview

- [EX2300 Switches Hardware Overview on page 3](#)
- [EX2300 Switch Models on page 11](#)
- [EX2300 Switch Hardware and CLI Terminology Mapping on page 13](#)

EX2300 Switches Hardware Overview

Juniper Networks EX Series Ethernet Switches provide scalable connectivity for the enterprise market, including branch offices, campus locations, and data centers. The Juniper Networks EX2300 Ethernet Switches run the Juniper Networks Junos operating system (Junos OS), which provides Layer 2 and Layer 3 switching, routing, and security services.

EX2300 switches provide connectivity for low-density environments.

This topic describes:

- [EX2300 Switches First View on page 3](#)
- [Uplink Ports on page 4](#)
- [Console Ports on page 4](#)
- [Cable Guard on page 4](#)
- [Security Slot on page 5](#)
- [Power over Ethernet \(PoE\) Ports on page 5](#)
- [Front Panel of an EX2300 Switch on page 5](#)
- [Rear Panel of an EX2300 Switch on page 8](#)

EX2300 Switches First View

EX2300 switches are available in models with 12 or 24, or 48 built-in network ports that support RJ-45 cable connectors. The compact, fanless EX2300-C switches have 12 RJ-45 network ports.

EX2300 switches provide:

- Up to four 10-Gigabit Ethernet uplink ports that support small form-factor pluggable plus (SFP+) transceivers and small form-factor pluggable (SFP) transceivers.
- 12 (in EX2300-C switches), 24, or 48 built-in Gigabit Ethernet RJ-45 network ports with 10/100/1000 BASE-T connectors.
- Virtual Chassis capability—You can connect up to four EX2300 switches (including EX2300-C switches) to form one unit that you manage as a single chassis, called a *Virtual Chassis*.
- Power over Ethernet (PoE) or Power over Ethernet Plus (PoE+) on all RJ-45 network ports (in PoE-capable models).

Uplink Ports

EX2300-C switches have two 10-Gigabit Ethernet uplink ports that support SFP and SFP+ transceivers. EX2300 switches except the EX2300-C switch model and the have four 10-Gigabit Ethernet uplink ports that support SFP and SFP+ transceivers. You can use these uplink ports as network ports or configure these ports as Virtual Chassis ports (VCPs) and use them to connect up to four switches by using SFP+ transceivers to form a Virtual Chassis.



NOTE: You cannot form a Virtual Chassis by using SFP transceivers.

For forming a Virtual Chassis, you must explicitly configure an uplink port on each of the switches to be connected as a VCP. See *Setting an Uplink Port on an EX Series Switch as a Virtual Chassis Port (CLI Procedure)*.

For information about the supported optical and copper interfaces, see [“Pluggable Transceivers Supported on EX2300 Switches” on page 75](#).

Console Ports

EX2300 switches have two console ports—an RJ-45 console port and a Mini-USB Type-B console port. The RJ-45 port accepts a cable that has an RJ-45 connector and the Mini-USB Type-B port accepts a Mini-B plug (5-pin) connector to connect the switch to a console management device.

Cable Guard

On an EX2300-C switch, you can install a cable guard to secure the cables connected to the switch. The cable guard has slots in the front of it through which you can pass all the cables to prevent them from being accidentally unplugged or removed after they are connected. See [“Mounting an EX2300 Switch on a Desk or Other Level Surface” on page 105](#), [“Mounting an EX2300-C Switch Under a Desk or Other Level Surface by Using Screws” on page 107](#), and [“Mounting an EX2300-C Switch on or Under a Surface Made of Ferrous Material” on page 126](#).

Security Slot

An EX2300-C switch has a security slot on the right panel of the chassis. You can use the security slot to lock and secure the chassis in the installation site with a standard cable lock. See “Mounting an EX2300 Switch on a Desk or Other Level Surface” on page 105, “Mounting an EX2300-C Switch Under a Desk or Other Level Surface by Using Screws” on page 107, and “Mounting an EX2300-C Switch on or Under a Surface Made of Ferrous Material” on page 126.

Power over Ethernet (PoE) Ports

EX2300 switches are available with or without PoE/PoE+ capability. Models that support PoE/PoE+ provide that support on all RJ-45 network ports. PoE ports provide electrical current to devices—such as IP phones, wireless access points, and security cameras—through network cables, thus eliminating the need for separate power cords for those devices. Uplink ports do not support PoE.



NOTE: IEEE 802.3at class 4 powered devices require category 5 or higher Ethernet cables.

The remainder of this topic uses the term PoE to refer to both PoE and PoE+ unless there is a need to distinguish between the two.

Front Panel of an EX2300 Switch

The front panel of an EX2300-C switch consists of the following components:

- RJ-45 network ports—depending on the switch model, either of:
 - 12 10/100/1000 BASE-T Gigabit Ethernet ports with PoE/PoE+ capability in EX2300-C-12P
 - 12 10/100/1000 BASE-T Gigabit Ethernet ports without PoE capability in EX2300-C-12T
- One USB port
- One management Ethernet port
- Three chassis status LEDs
- Four port status mode LEDs in models with PoE capability and three port status mode LEDs in models without PoE capability
- One Factory Reset/Mode button
- One mini-USB console port
- One RJ-45 console port

- Two built-in 10-Gigabit Ethernet uplink ports. You can use the uplink ports to forward network traffic or configure them as VCPs to interconnect EX2300 switches into a Virtual Chassis.
- One electrostatic discharge (ESD) point

Figure 1 on page 6 shows the front panel of an EX2300-C switch with 12 Gigabit Ethernet ports with PoE capability and Figure 2 on page 6 shows the front panel of an EX2300-C switch with 12 Gigabit Ethernet ports without PoE capability.

Figure 1: Front Panel of an EX2300-C Switch with 12 Gigabit Ethernet Ports with PoE Capability

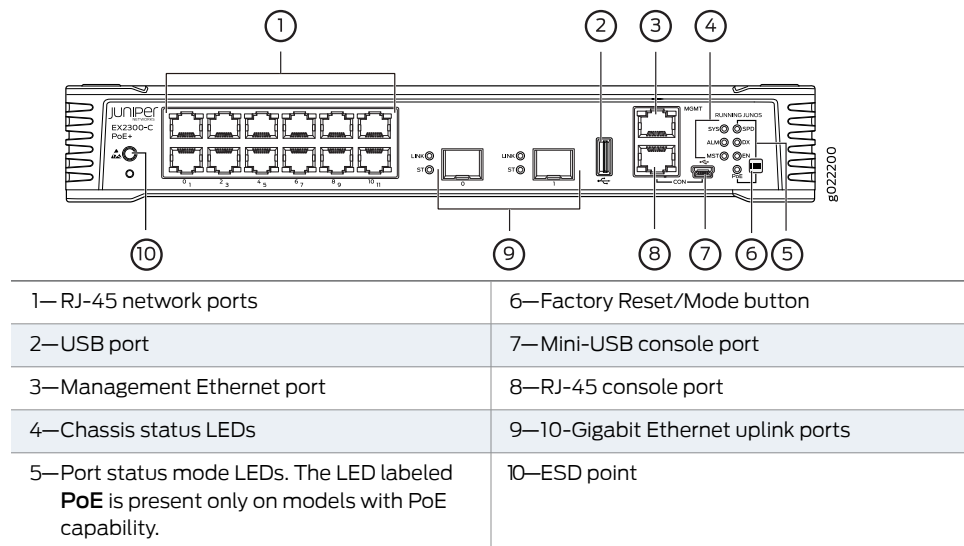
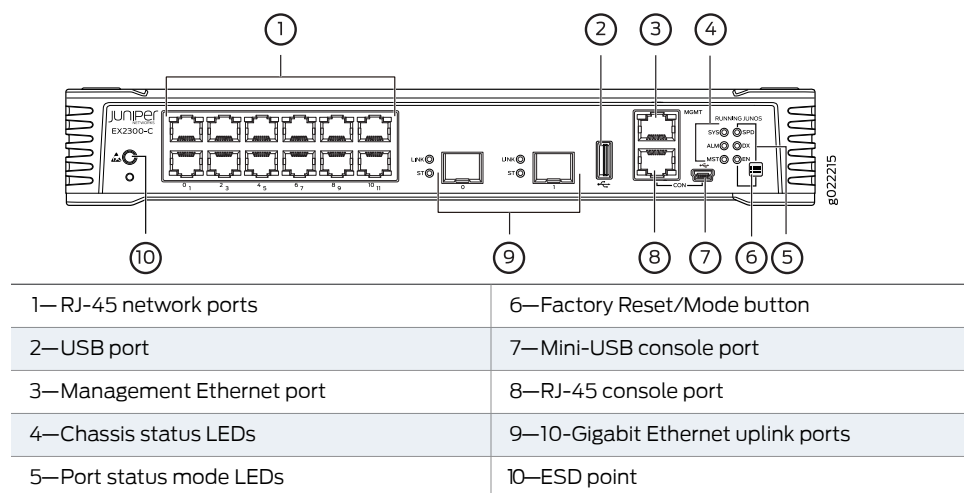

Figure 2: Front Panel of an EX2300-C Switch with 12 Gigabit Ethernet Ports without PoE Capability



The front panel of EX2300 switches except the EX2300-C switch models consists of the following components:

- RJ-45 network ports—depending on the switch model, either of:
 - 24 or 48 10/100/1000 BASE-T Gigabit Ethernet ports without PoE capability in the EX2300-24T, EX2300-24T-DC and EX2300-48T models
 - 24 or 48 10/100/1000 BASE-T Gigabit Ethernet ports with PoE/PoE+ capability in the EX2300-24P and EX2300-48P model
- Three chassis status LEDs
- Four port status mode LEDs in models with PoE capability and three port status mode LEDs in models without PoE capability
- One Factory Reset/Mode button
- One mini-USB console port
- Four built-in 10-Gigabit Ethernet uplink ports . You can use these ports to forward network traffic or configure them into VCPs to interconnect EX2300 switches into a Virtual Chassis.

Figure 3 on page 7 shows the front panel of an EX2300 switch with 24 Gigabit Ethernet ports with PoE capability and Figure 4 on page 8 shows the front panel of an EX2300 switch with 48 Gigabit Ethernet ports.

Figure 3: Front Panel of an EX2300 Switch with 24 Gigabit Ethernet Ports with PoE Capability

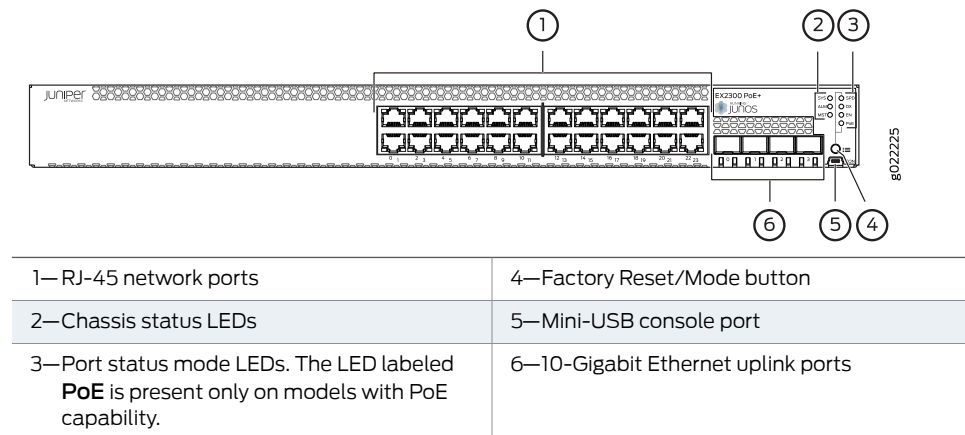
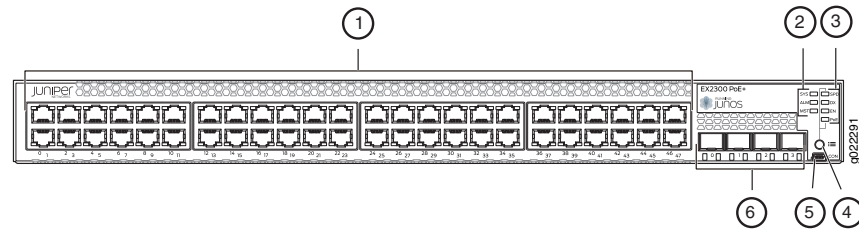

Figure 4: Front Panel of an EX2300 Switch with 48 Gigabit Ethernet Ports with PoE Capability



1—RJ-45 network ports	4—Factory Reset/Mode button
2—Chassis status LEDs	5—Mini-USB console port
3—Port status mode LEDs. The LED labeled PoE is present only on models with PoE capability.	6—10-Gigabit Ethernet uplink ports

Rear Panel of an EX2300 Switch

The rear panel of an EX2300-C switch consists of the following components:

- Serial number ID label
- CLEI code label
- One protective earthing terminal
- Heatsink
- One AC power cord inlet

Figure 5 on page 8 shows the rear panel of an EX2300-C switch with 12 Gigabit Ethernet ports with PoE capability and Figure 6 on page 9 shows the rear panel of an EX2300-C switch with 12 Gigabit Ethernet ports without PoE capability.

EX2300-C switches being fanless models have no exhaust openings. EX2300 switches have vents on the top of the chassis. The PoE models have a heatsink installed in the rear panel to dissipate heat, while non-PoE models have no heatsink.

Figure 5: Rear Panel of an EX2300-C Switch with 12 Gigabit Ethernet Ports with PoE Capability

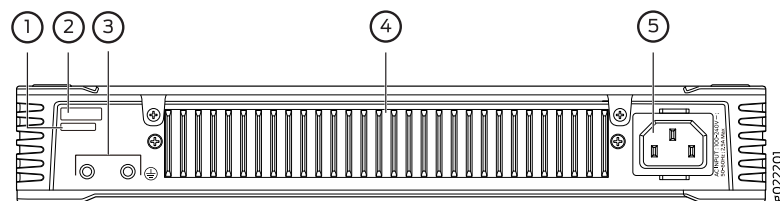

1—CLEI code label	4—Heatsink—only in PoE models
2—Serial number ID label	5—AC power cord inlet
3—Protective earthing terminal	

Figure 6: Rear Panel of an EX2300-C Switch with 12 Gigabit Ethernet Ports without PoE Capability

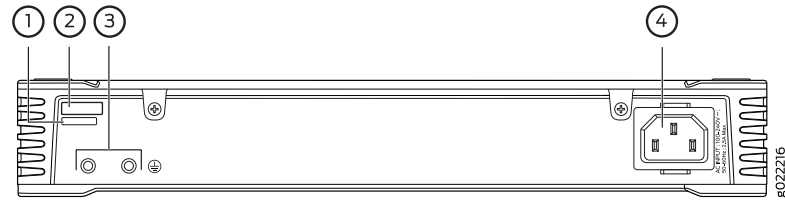

1—CLEI code label	3—Protective earthing terminal
2—Serial number ID label	4—AC power cord inlet

The rear panel of the EX2300 switch except the EX2300-C switch consists of the following components:

- One management Ethernet port that supports an RJ-45 connector
- One console port that supports an RJ-45 connector
- One protective earthing terminal
- One ESD point
- Air exhaust openings
- Serial number ID label
- CLEI code label
- One AC power cord inlet or DC power terminals
- One USB port

[Figure 7 on page 10](#) shows the rear panel of an AC-powered EX2300 switch with 24 Gigabit Ethernet ports with PoE capability except the and [Figure 10 on page 11](#) shows the rear panel of an EX2300 switch with 48 Gigabit Ethernet ports with PoE capability. [Figure 8 on page 10](#) shows the rear panel of an AC-powered EX2300 switch with 24 Gigabit Ethernet ports without PoE capability and [Figure 11 on page 11](#) shows the rear panel of an EX2300 switch with 48 Gigabit Ethernet ports without PoE capability. [Figure 9 on page 10](#) shows the rear panel of a DC-powered EX2300 switch with 24 Gigabit Ethernet ports.



NOTE: DC-powered EX2300 switches do not provide PoE.

The AC power cord retainer clips extend out of the chassis by 3 in (7.62 cm).

Figure 7: Rear Panel of an AC-Powered EX2300 Switch with 24 Gigabit Ethernet Ports with PoE Capability

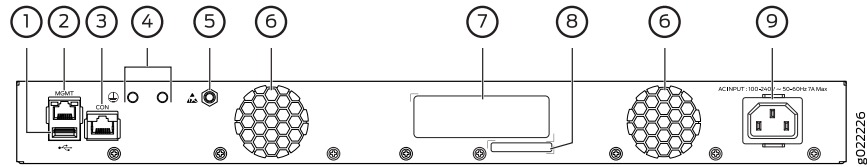

1—USB port	6—Air exhaust openings
2—Management Ethernet port	7—Serial number ID label
3—RJ-45 console port	8—CLEI code label
4—Protective earthing terminal	9—AC power cord inlet
5—ESD point	

Figure 8: Rear Panel of an AC-Powered EX2300 Switch with 24 Gigabit Ethernet Ports without PoE Capability

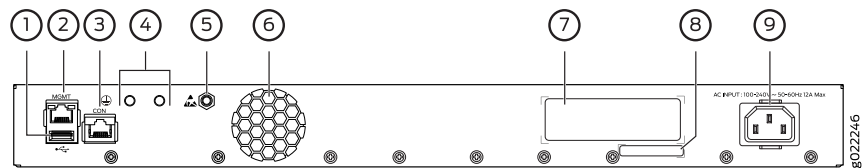

1—USB port	6—Air exhaust opening
2—Management Ethernet port	7—Serial number ID label
3—RJ-45 console port	8—CLEI code label
4—Protective earthing terminal	9—AC power cord inlet
5—ESD point	

Figure 9: Rear Panel of a DC-Powered EX2300 Switch with 24 Gigabit Ethernet Ports

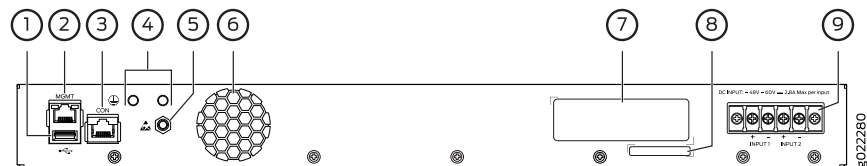

1—USB port	6—Air exhaust opening
2—Management Ethernet port	7—Serial number ID label
3—RJ-45 console port	8—CLEI code label
4—Protective earthing terminal	9—DC power terminals
5—ESD point	

Figure 10: Rear Panel of an AC-Powered EX2300 Switch with 48 Gigabit Ethernet Ports with PoE Capability

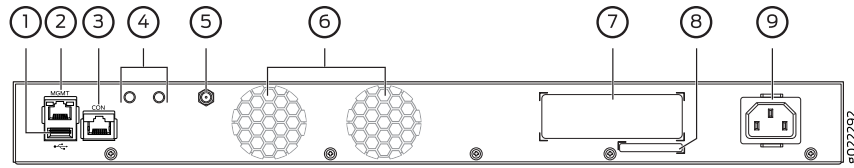

1—USB port	6—Air exhaust openings
2—Management Ethernet port	7—Serial number ID label
3—RJ-45 console port	8—CLEI code label
4—Protective earthing terminal	9—AC power cord inlet
5—ESD point	

Figure 11: Rear Panel of an AC-Powered EX2300 Switch with 48 Gigabit Ethernet Ports without PoE Capability



1—USB port	6—Air exhaust opening
2—Management Ethernet port	7—Serial number ID label
3—RJ-45 console port	8—CLEI code label
4—Protective earthing terminal	9—AC power cord inlet
5—ESD point	

- Related Documentation**
- [EX2300 Switch Models on page 11](#)
 - [Site Preparation Checklist for EX2300 Switches on page 53](#)

EX2300 Switch Models

The EX2300 switch is available with 12 or 24, or 48 built-in RJ-45 network ports with full Power over Ethernet (PoE) or Power over Ethernet plus (PoE+) capability on all built-in RJ-45 network ports (access ports), or no PoE capability. [Table 3 on page 12](#) lists the EX2300 switch models.

EX2300-C switches have two uplink ports. EX2300 switches except the EX2300-C switch model and the EX2300-48MP switch model have four uplink ports. The EX2300-48MP switch model has six 10-Gigabit Ethernet uplink ports. These uplink ports support SFP and SFP+ transceivers. You can use these uplink ports as network ports or configure these ports as Virtual Chassis ports (VCPs) and use them to connect up to four switches by using SFP+ transceivers to form a Virtual Chassis. You cannot form a Virtual Chassis by using SFP transceivers. Uplink ports do not support PoE.

Table 3: EX2300 Switch Models

Model	Access Ports	Virtual Chassis License	Ports in Which PoE Is Available	Maximum System Power Available for PoE/PoE+	First Junos OS Release
EX2300-C-12T	12 Gigabit Ethernet	Not available	–	–	15.1X53-D50
EX2300-C-12T-VC	12 Gigabit Ethernet	Available	–	–	15.1X53-D50
EX2300-C-12T-TAA	12 Gigabit Ethernet	Not available	–	–	15.1X53-D50
EX2300-C-12P	12 Gigabit Ethernet	Not available	All 12 ports	124 W	15.1X53-D50
EX2300-C-12P-VC	12 Gigabit Ethernet	Available	All 12 ports	124 W	15.1X53-D50
EX2300-C-12P-TAA	12 Gigabit Ethernet	Not available	All 12 ports	124 W	15.1X53-D50
EX2300-24T	24 Gigabit Ethernet	Not available	–	–	15.1X53-D50
EX2300-24T-VC	24 Gigabit Ethernet	Available	–	–	15.1X53-D50
EX2300-24T-TAA	24 Gigabit Ethernet	Not available	–	–	15.1X53-D50
EX2300-24T-DC	24 Gigabit Ethernet	Not available	–	–	15.1X53-D51
EX2300-24P	24 Gigabit Ethernet	Not available	All 24 ports	370 W	15.1X53-D50
EX2300-24P-VC	24 Gigabit Ethernet	Available	All 24 ports	370 W	15.1X53-D50
EX2300-24P-TAA	24 Gigabit Ethernet	Not available	All 24 ports	370 W	15.1X53-D50
EX2300-24MP	24 Gigabit Ethernet	Not available	All 24 ports	380 W	18.1
EX2300-48T	48 Gigabit Ethernet	Not available	–	–	15.1X53-D55
EX2300-48T-VC	48 Gigabit Ethernet	Available	–	–	15.1X53-D55
EX2300-48T-TAA	48 Gigabit Ethernet	Not available	–	–	15.1X53-D55
EX2300-48P	48 Gigabit Ethernet	Not available	All 48 ports	405 W	15.1X53-D55
EX2300-48P-VC	48 Gigabit Ethernet	Available	All 48 ports	405 W	15.1X53-D55
EX2300-48P-TAA	48 Gigabit Ethernet	Not available	All 48 ports	405 W	15.1X53-D55
EX2300-48MP	48 Gigabit Ethernet	Not available	All 48 ports	740 W	18.1

Related Documentation • [EX2300 Switches Hardware Overview on page 3](#)

EX2300 Switch Hardware and CLI Terminology Mapping

This topic describes the hardware terms used in EX2300 switch documentation and the corresponding terms used in the Junos OS CLI. See [Table 4 on page 13](#).

Table 4: CLI Equivalents of Terms Used in Documentation for EX2300 Switches

Hardware Item (as Displayed in the CLI)	Description (as Displayed in the CLI)	Value (as Displayed in the CLI)	Item in Documentation	Additional Information
Chassis	One of the following: <ul style="list-style-type: none"> • EX2300-C-12T • EX2300-C-12P • EX2300-24T • EX2300-24P • EX2300-24MP • EX2300-24T-DC • EX2300-48T • EX2300-48P • EX2300-48MP 	–	Switch chassis	“Chassis Physical Specifications for EX2300 Switches” on page 15
FPC (<i>n</i>)	Abbreviated name of the Flexible PIC Concentrator (FPC) One of the following: <ul style="list-style-type: none"> • EX2300-C-12T • EX2300-C-12P • EX2300-24T • EX2300-24P • EX2300-24MP • EX2300-24T-DC • EX2300-48T • EX2300-48P • EX2300-48MP 	Value of <i>n</i> is always 0.	The switch does not have actual FPCs. In this case, FPC refers to the switch itself.	<i>Understanding Interface Naming Conventions on EX Series Switches</i>
	On EX2300 Virtual Chassis: <ul style="list-style-type: none"> • Member ID of the switch within the Virtual Chassis 	<i>n</i> is a value in the range of 0 through 3.	In this case, the FPC number refers to the member ID assigned to the switch.	<i>Understanding EX Series Virtual Chassis Components</i>

Table 4: CLI Equivalents of Terms Used in Documentation for EX2300 Switches (*continued*)

Hardware Item (as Displayed in the CLI)	Description (as Displayed in the CLI)	Value (as Displayed in the CLI)	Item in Documentation	Additional Information
PIC (<i>n</i>)	Abbreviated name of the Physical Interface Card (PIC)	<i>n</i> is a value in the range 0 through 1.	The switch does not have actual PIC devices; see entries for PIC 0 through PIC 1 for the equivalent item on the switch	<i>Understanding Interface Naming Conventions on EX Series Switches</i>
	One of the following: <ul style="list-style-type: none"> 12x 10/100/1000 BASE-T 8x 100/1000/2500 BASE-T 16x 10/100/1000 BASE-T 24x 10/100/1000 BASE-T 48x 10/100/1000 BASE-T 16x 100/1000/2500 BASE-T 32x 10/100/1000 BASE-T 	PIC 0	Built-in RJ-45 network ports on the front panel of the switch	“EX2300 Switches Hardware Overview” on page 3
	One of the following: <ul style="list-style-type: none"> 2x10G SFP/SFP+ or 4x10G SFP/SFP+ 6x10G SFP/SFP+ 	PIC 1	Built-in uplink ports on the front panel of the switch	“EX2300 Switches Hardware Overview” on page 3
Xcvr (<i>n</i>)	Abbreviated name of the transceiver	<i>n</i> is a value equivalent to the number of the port in which the transceiver is installed.	Optical transceivers	“Pluggable Transceivers Supported on EX2300 Switches” on page 75
Power Supply (<i>n</i>)	Built-in power supply	Value of <i>n</i> is always 0.	AC power supply or DC power supply	“Power Supply in EX2300 Switches” on page 29
Fan Tray	Fan <i>NOTE:</i> EX2300-C switches are fanless models.	–	Fan	“Cooling System and Airflow in an EX2300 Switch” on page 25

Related Documentation • [EX2300 Switches Hardware Overview on page 3](#)

CHAPTER 2

Chassis Components and Descriptions

- [Chassis Physical Specifications for EX2300 Switches on page 15](#)
- [Chassis Status LEDs in EX2300 Switches on page 16](#)
- [Management Port LEDs in EX2300 Switches on page 20](#)
- [RJ-45 Network Port LEDs and Uplink Port LEDs in EX2300 Switches on page 21](#)

Chassis Physical Specifications for EX2300 Switches

The EX2300 switch chassis is a rigid sheet-metal structure that houses the hardware components. [Table 5 on page 15](#) summarizes the physical specifications of the EX2300 switch chassis.

Table 5: Physical Specifications of the EX2300 Switch Chassis

Description	EX2300-C Value	EX2300 Value
Chassis height	1.72 in. (4.36 cm)	<ul style="list-style-type: none">• All models except EX2300-24MP and EX2300-48MP—1.75 in. (4.45 cm)• EX2300-24MP and EX2300-48MP models—1.7 in. (4.33 cm)
Chassis width	<ul style="list-style-type: none">• 10.98 in. (27.9 cm)• 18.86 in. (47.9 cm) with mounting brackets attached	<ul style="list-style-type: none">• All models except EX2300-24MP and EX2300-48MP<ul style="list-style-type: none">• 17.4 in. (44.19 cm)• 19 in. (48.26 cm) with mounting brackets attached• EX2300-24MP and EX2300-48MP models<ul style="list-style-type: none">• 17.36 in. (44.09 cm)• 18.95 in. (48.13 cm) with mounting brackets attached

Table 5: Physical Specifications of the EX2300 Switch Chassis (*continued*)

Description	EX2300-C Value	EX2300 Value
Chassis depth	9.45 in. (23.8 cm)	<ul style="list-style-type: none"> All models except EX2300-24MP and EX2300-48MP Models without PoE capability: 10.2 in. (25.9 cm) Models with PoE capability: 12.2 in. (30.98 cm) EX2300-24MP—10 in. (25.4 cm) EX2300-48MP—14.45 in. (36.71 cm)
Weight	<ul style="list-style-type: none"> EX2300-C-12T: 5.45 lb (2.48 kg) EX2300-C-12P: 6.99 lb (3.17 kg) 	<ul style="list-style-type: none"> EX2300-24T: 7.25 lb (3.29 kg) EX2300-24P: 9.89 lb (4.49 kg) EX2300-24MP: 8.8 lb (4 kg) EX2300-24T-DC: 7.83 lb (3.55 kg) EX2300-48T: 8.28 lb (3.76 kg) EX2300-48P: 11.06 lb (5.02 kg) EX2300-48MP: 14.33 lb (6.5 kg)

- Related Documentation**
- [Rack Requirements on page 61](#)
 - [Cabinet Requirements on page 63](#)
 - [Mounting an EX2300 Switch on page 104](#)
 - [Installing and Connecting an EX2300 Switch on page 103](#)

Chassis Status LEDs in EX2300 Switches

The front panel of EX2300 switches except the EX2300-24MP and EX2300-48 MP models has three chassis status LEDs labeled **SYS**, **ALM**, and **MST**. See [Figure 12 on page 16](#) and [Figure 13 on page 17](#).

Figure 12: Chassis Status LEDs in EX2300-C Switches

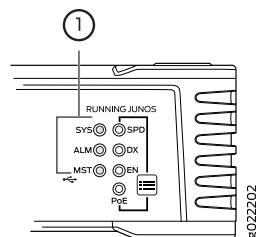

1— Chassis Status LEDs

Figure 13: Chassis Status LEDs in EX2300 Switches Except the EX2300-C, EX2300-24MP and EX2300-48MP Models

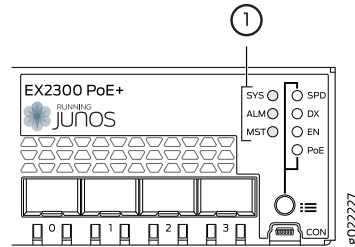

1— Chassis Status LEDs

Table 6 on page 17 describes the chassis status LEDs in EX2300 switches except the EX2300-24MP and EX2300-48 MP models, their colors and states, and the status they indicate.

Table 6: Chassis Status LEDs in EX2300 Switches Except the EX2300-24MP and EX2300-48 MP Models

LED Label	Color	State and Description
SYS	Green	<ul style="list-style-type: none"> On steadily—Junos OS for EX Series switches has been loaded on the switch. Blinking—The switch is booting. Off—The switch is powered off or is halted.
ALM	Red	<p>There is a major alarm.</p> <p>NOTE: When you connect power to the switch, the alarm LED (ALM) glows red. This behavior is normal. Plugging an active Ethernet cable into the management port (MGMT) on the switch completes the network link and turns off the ALM LED. (See “Connecting a Device to a Network for Out-of-Band Management” on page 147.)</p> <p>Connecting the switch to a dedicated management console instead of a network does not affect the ALM LED. The LED remains red until the switch is connected to a network.</p>
	Yellow	<p>There is a minor alarm.</p> <p>NOTE: The ALM LED glows yellow if you commit a configuration to make it active on the switch without creating a rescue configuration to back it up. To save the most recently committed configuration as the rescue configuration, enter the operational mode command <code>request system configuration rescue save</code>.</p>
	Unlit	There is no alarm or the switch is halted.

Table 6: Chassis Status LEDs in EX2300 Switches Except the EX2300-24MP and EX2300-48 MP Models (*continued*)

LED Label	Color	State and Description
MST	Green	<p>In a standalone EX2300 switch:</p> <ul style="list-style-type: none"> On steadily—The switch is functioning normally as the master. Off—The switch is powered off or is halted. <p>In a Virtual Chassis configuration:</p> <ul style="list-style-type: none"> On steadily—The switch is functioning normally and is the master in the Virtual Chassis configuration. Blinking—The switch is functioning normally and is the backup in the Virtual Chassis configuration. Off—The switch is a linecard member in the Virtual Chassis configuration or is halted.

A major alarm (red) indicates a critical error condition that requires immediate action.

A minor alarm (yellow) indicates a noncritical condition that requires monitoring or maintenance. A minor alarm that is left unchecked might cause interruption in service or performance degradation.

All three LEDs can be lit simultaneously.

You can view the colors of the two LEDs remotely through the CLI by issuing the operational mode command `show chassis led`.

The front panel of EX2300-24MP and EX2300-48 MP models has three chassis status LEDs labeled **SYS**, **ALM**, and **MST**. See [Figure 14 on page 18](#).

Figure 14: Chassis Status LEDs in EX2300-24MP and EX2300-48MP Models

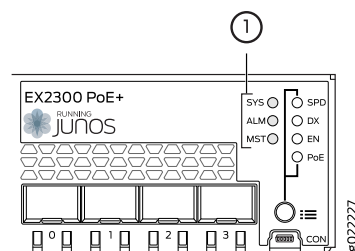

1— Chassis Status LEDs

[Table 7 on page 19](#) describes the chassis status LEDs in EX2300-24MP and EX2300-48 MP models, their colors and states, and the status they indicate.

Table 7: Chassis Status LEDs in EX2300-24MP and EX2300-48 MP Models

LED Label	Color	State and Description
SYS	Green	<ul style="list-style-type: none"> On steadily—Junos OS for EX Series switches has been loaded on the switch. Blinking—The switch is booting. Off—The switch is powered off or is halted.
ALM	Red	<p>There is a major alarm.</p> <p>NOTE: When you connect power to the switch, the alarm LED (ALM) glows red. This behavior is normal. Plugging an active Ethernet cable into the management port (MGMT) on the switch completes the network link and turns off the ALM LED. (See “Connecting a Device to a Network for Out-of-Band Management” on page 147.)</p> <p>Connecting the switch to a dedicated management console instead of a network does not affect the ALM LED. The LED remains red until the switch is connected to a network.</p>
	Yellow	<p>There is a minor alarm.</p> <p>NOTE: The ALM LED glows yellow if you commit a configuration to make it active on the switch without creating a rescue configuration to back it up. To save the most recently committed configuration as the rescue configuration, enter the operational mode command <code>request system configuration rescue save</code>.</p>
	Unlit	There is no alarm or the switch is halted.
MST	Green	<p>In a standalone EX2300 switch:</p> <ul style="list-style-type: none"> On steadily—The switch is functioning normally as the master. Off—The switch is powered off or is halted. <p>In a Virtual Chassis configuration:</p> <ul style="list-style-type: none"> On steadily—The switch is functioning normally and is the master in the Virtual Chassis configuration. Blinking—The switch is functioning normally and is the backup in the Virtual Chassis configuration. Off—The switch is a linecard member in the Virtual Chassis configuration or is halted.

A major alarm (red) indicates a critical error condition that requires immediate action.

A minor alarm (yellow) indicates a noncritical condition that requires monitoring or maintenance. A minor alarm that is left unchecked might cause interruption in service or performance degradation.

All LEDs can be lit simultaneously.

Related Documentation

- [EX2300 Switches Hardware Overview on page 3](#)
- [Chassis Component Alarm Conditions on EX2300 Switches on page 194](#)
- [Checking Active Alarms with the J-Web Interface on page 196](#)
- [Understanding Alarm Types and Severity Levels on EX Series Switches on page 193](#)

Management Port LEDs in EX2300 Switches

The management port on an EX2300 switch has two LEDs that indicate link/activity and port status. The EX2300 switches except the EX2300-C switch and EX2300-24MP and EX2300-48MP models have the management port on the rear panel; the EX2300-C switches and EX2300-24MP and EX2300-48MP models have the management port on the front panel. See [Figure 15 on page 20](#) and [Figure 16 on page 20](#).

Figure 15: LEDs on the Management Port on EX2300-C Switches

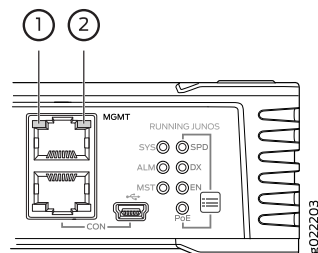

1—Link/Activity LED

2—Status LED

Figure 16: LEDs on the Management Port on EX2300 Switches Except EX2300-24MP and EX2300-48MP Models

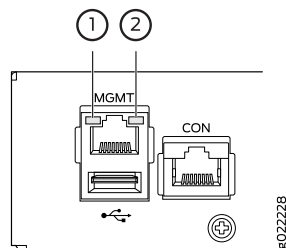

1—Link/Activity LED

2—Status LED

[Table 8 on page 21](#) describes the Link/Activity LED.

Table 8: Link/Activity LED on the Management Port on EX2300 Switches

LED	Color	State and Description
Link/Activity	Green	<ul style="list-style-type: none"> Blinking—The port and the link are active, and there is link activity. Off—The port is not active.

Table 9 on page 21 describes the Status LED.

Table 9: Status LED on the Management Port on EX2300 Switches

LED	Color	State and Description
Status	Green	Indicates the speed. The speed indicators are: <ul style="list-style-type: none"> Off—Link speed is 10 Mbps. Blinking—Link speed is 100 Mbps. On Steadily—Link speed is 1000 Mbps.

Related Documentation • [Connecting a Device to a Network for Out-of-Band Management on page 147](#)

RJ-45 Network Port LEDs and Uplink Port LEDs in EX2300 Switches

Each RJ-45 network port and uplink port on the front panel of an EX2300 switch has two LEDs that indicate link/activity and port status. See [Figure 17 on page 21](#), [Figure 18 on page 21](#), and [Figure 19 on page 22](#).

Figure 17: LEDs on RJ-45 Network Ports

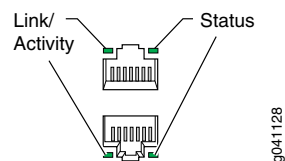
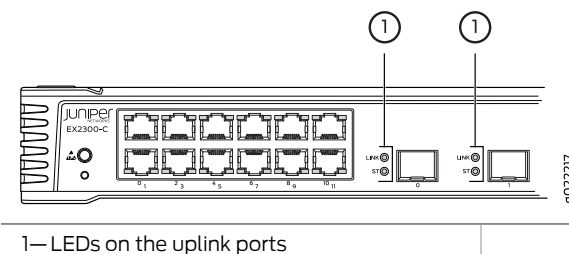
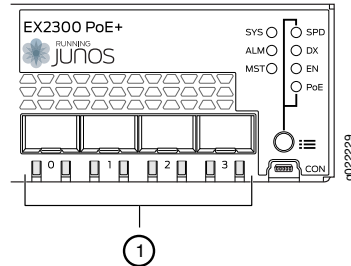

Figure 18: LEDs on the Uplink Ports in EX2300-C Switches



1—LEDs on the uplink ports

Figure 19: LEDs on the Uplink Ports in an EX2300 Switches Except the EX2300-C Switches



1— LEDs on the uplink ports

Table 10 on page 22 describes the Link/Activity LED.

Table 10: Link/Activity LED on the RJ-45 Network Ports and the Uplink Ports in EX2300 Switches

LED	Color	State and Description
Link/Activity	Green	<ul style="list-style-type: none"> Blinking—The port and the link are active, and there is link activity. On steadily—The port and the link are active, but there is no link activity. Off—The port is not active.

Figure 20 on page 22 shows the LEDs that indicate the status of one of the four port parameters—speed, duplex mode, administrative status, and Power over Ethernet (PoE) status. Use the Factory Reset/Mode button on the far right side of the front panel to toggle the Status LED to show the different port parameters for RJ-45 network ports. You can tell which port parameter is indicated by the Status LED by looking at which port status mode LED (SPD, DX, EN, and PoE) is lit. The LED labeled PoE is not available on switch models with RJ-45 network ports that do not provide PoE.

Figure 20: Port Mode LEDs on EX2300 Switches

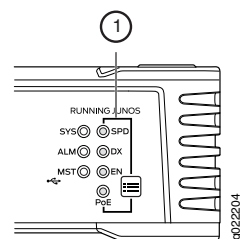

1— Port mode LEDs

Table 11 on page 23 describes the Status LED on the RJ-45 network ports.

Table 11: Status LED on the RJ-45 Network Ports in EX2300 Switches

Port Parameters	State and Description
Speed (SPD)	Indicates the speed. The speed indicators are: <ul style="list-style-type: none"> Unlit—10 Mbps Blinking—100 Mbps On steadily—1000 Mbps
Duplex mode (DX) NOTE: On EX2300-24T switches, only the ports labeled 0/0 through 0/15 support half-duplex. On EX2300-48T switches, only the ports labeled 0/0 through 0/15 and 0/24 through 0/39 support half-duplex.	Indicates the duplex mode. The status indicators are: <ul style="list-style-type: none"> Green—Port is set to full-duplex mode. Unlit—Port is set to half-duplex mode.
Administrative status (EN)	Indicates the administrative status. The status indicators are: <ul style="list-style-type: none"> Green—Port is administratively enabled. Unlit—Port is administratively disabled.
PoE status (PoE)	Indicates the PoE status. The status indicators are: <ul style="list-style-type: none"> On steadily—PoE is enabled on the port and a device is drawing power. Blinking—PoE is enabled on the port, but no power is drawn from the port. Unlit—PoE is not enabled on the port. <p>NOTE: The PoE Status LED is available on the following EX2300 switch models:</p> <ul style="list-style-type: none"> EX2300-C-12P EX2300-24P EX2300-24MP EX2300-48P EX2300-48MP

The uplink ports operate in full-duplex mode and PoE is not applicable on uplink ports. The Status LED on uplink ports indicate the Speed (SPD) and Administrative status (EN). [Table 12 on page 23](#) describes the Status LED on the uplink ports.

Table 12: Status LED on the Uplink Ports in EX2300 Switches

LED	State and Description
Status LED	Indicates the speed and administrative status. The indicators are: <ul style="list-style-type: none"> On steadily—10 Gbps Blinking—1 Gbps Unlit—The port is administratively disabled or the link is down.

You can tell which port parameter is indicated by the Status LED on RJ-45 network ports and uplink ports by issuing the operational mode command **show chassis led**.

- Related Documentation**
- [EX2300 Switches Hardware Overview on page 3](#)
 - *Configuring Gigabit Ethernet Interfaces (CLI Procedure)*
 - *Configuring Gigabit Ethernet Interfaces (J-Web Procedure)*

CHAPTER 3

Cooling System and Airflow

- [Cooling System and Airflow in an EX2300 Switch on page 25](#)

Cooling System and Airflow in an EX2300 Switch

The cooling system in EX2300 switches—except EX2300-C which is the compact, fanless model—consists of two fans along the rear of the chassis that provide front-to-back chassis cooling.

The cooling system in EX2300-C switches consists of the vents on the top of the chassis and the heatsinks installed in the rear panel in PoE models. Do not block the vents on the chassis; doing so can lead to overheating of the switch chassis.

This topic describes:

- [Airflow Direction in EX2300 Switches with 24 Ports with PoE Capability on page 25](#)
- [Airflow Direction in EX2300 Switches with 48 Ports with PoE Capability on page 26](#)
- [Airflow Direction in EX2300 Switches without PoE Capability on page 27](#)

Airflow Direction in EX2300 Switches with 24 Ports with PoE Capability

[Figure 21 on page 26](#) shows the airflow in EX2300 switches with 24 ports with PoE capability.

Figure 21: Airflow Direction in EX2300 Switches with 24 Ports with PoE Capability

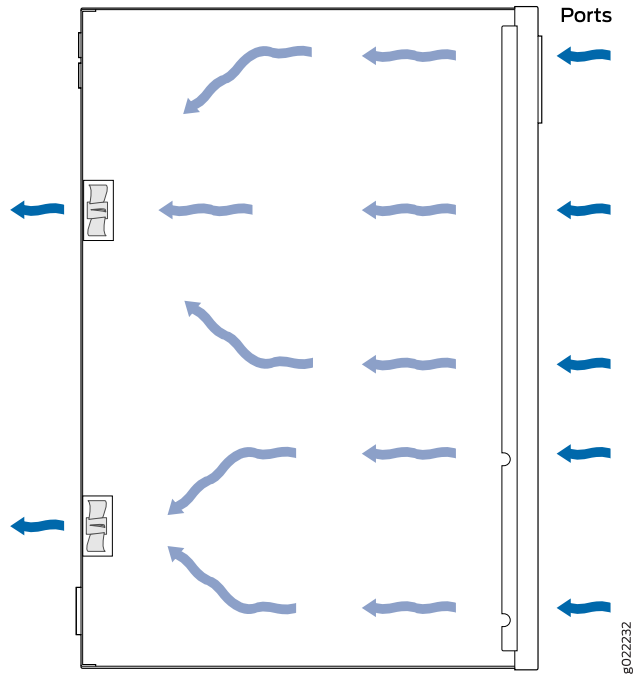

Airflow Direction in EX2300 Switches with 48 Ports with PoE Capability

Figure 22 on page 27 shows the airflow in EX2300 switches with 48 ports with PoE capability.

Figure 22: Airflow Direction in EX2300 Switches with 48 Ports with PoE Capability

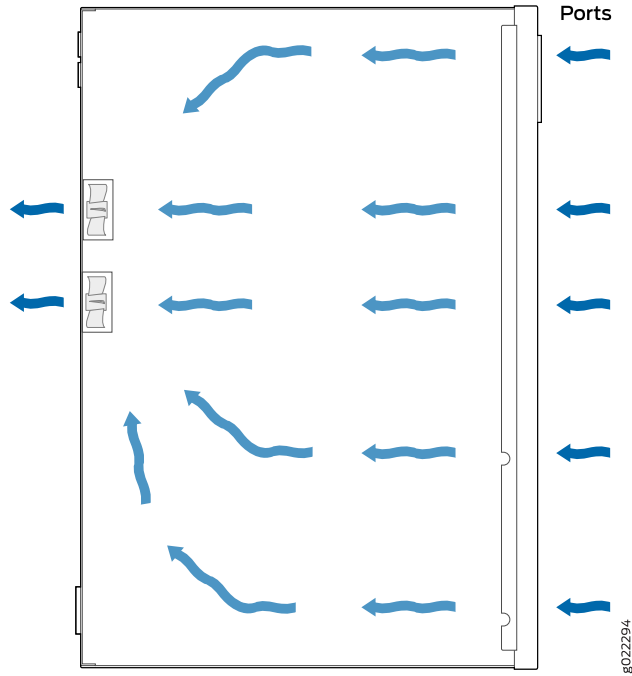

Airflow Direction in EX2300 Switches without PoE Capability

Figure 23 on page 28 shows the airflow in EX2300 switches without PoE capability.

Figure 23: Airflow Direction in EX2300 Switches with 24 Ports without PoE Capability

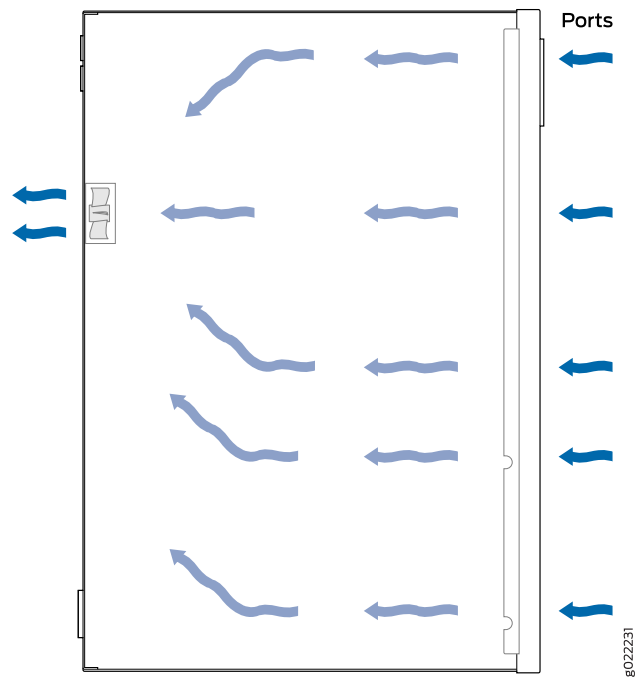

Under normal operating conditions, the fans operate at a moderate speed to reduce noise. Temperature sensors in the chassis monitor the temperature within the chassis. If any fan fails or if the temperature inside the chassis rises above the threshold, the switch raises an alarm and all functioning fans operate at a higher speed than normal. If the temperature inside the chassis rises above the threshold, the switch shuts down automatically.

Related Documentation

- [EX2300 Switches Hardware Overview on page 3](#)
- [Chassis Status LEDs in EX2300 Switches on page 16](#)
- [Understanding Alarm Types and Severity Levels on EX Series Switches on page 193](#)
- [Prevention of Electrostatic Discharge Damage on page 243](#)

Power Supplies

- [Power Supply in EX2300 Switches on page 29](#)

Power Supply in EX2300 Switches

The power supply in EX2300 switches is built in along the rear panel of the chassis, with an AC power cord inlet or DC power terminals on the rear panel to connect power to the switch.



NOTE: After powering on the switch, wait for at least 60 seconds before powering it off. After powering off the switch, wait for at least 60 seconds before powering it back on.

[Table 13 on page 29](#) lists the power consumed by each EX2300 switch model.

Table 13: Power Consumed by EX2300 Switches

Model Number	Number of PoE-Enabled Ports	Maximum Power Consumed by the Switch	Maximum PoE/PoE+ Power Available
EX2300-C-12T	–	20 W	–
EX2300-C-12P	12	24 W (when no PoE power is drawn)	124 W
EX2300-24T	–	55 W	–
EX2300-24P	24	80 W (when no PoE power is drawn)	370 W
EX2300-24MP	24	100 W (when no PoE power is drawn)	380 W
EX2300-24T-DC	–	55 W	–
EX2300-48T	–	76 W	–
EX2300-48P	48	91 W (when no PoE power is drawn)	405 W

Table 13: Power Consumed by EX2300 Switches (*continued*)

Model Number	Number of PoE-Enabled Ports	Maximum Power Consumed by the Switch	Maximum PoE/PoE+ Power Available
EX2300-48MP	48	227 W (when no PoE power is drawn)	740 W

- Related Documentation**
- [AC Power Cord Specifications for EX2300 Switches on page 70](#)
 - [EX2300 Switches Hardware Overview on page 3](#)
 - [Power Specifications for EX2300 Switches on page 69](#)
 - [Connecting AC Power to an EX2300 Switch on page 140](#)
 - [Connecting DC Power to an EX2300 Switch on page 143](#)
 - [Connecting Earth Ground to an EX Series Switch on page 133](#)

CHAPTER 5

Viewing System Information

- [Dashboard for EX Series Switches on page 31](#)

Dashboard for EX Series Switches



NOTE: This topic applies only to the J-Web Application package.

When you log in to the J-Web user interface, the dashboard for the Juniper Networks EX Series Ethernet Switches appears. Use the dashboard to view system information.

The Update Available window appears if there is a latest update of the J-Web Application package available on the Juniper Networks server. This window is enabled by the auto update feature of J-Web.



NOTE:

- The Update Available window will *not* appear when you log in, if you have not selected the *Check for updates automatically on every login* in the *Update Preference* section in the *Maintain > Update J-Web* side pane. By default, the *Check for update automatically on every login* is selected.
- If you choose *Update Later*, you can update to the latest J-Web Application package by clicking the orange icon next to *Update Available* on the top pane of the J-Web interface or through *Maintain > Update J-Web*.

The dashboard comprises a graphical chassis viewer and four panels.

This topic describes:

- [Graphical Chassis Viewer on page 32](#)
- [System Information Panel on page 33](#)
- [Health Status Panel on page 35](#)
- [Capacity Utilization Panel on page 37](#)
- [Alarms Panel on page 37](#)

- [File System Usage on page 38](#)
- [Chassis Viewer on page 38](#)

Graphical Chassis Viewer

The Dashboard panel displays a graphical view of the chassis of a switch. In a Virtual Chassis, it displays a graphical view of each member switch.

In a Virtual Chassis, the default values are shown on the Dashboard panel when no chassis image is clicked. The panel displays the value for a switch if you click its image.



NOTE: If the member switch is not present, inactive, or not provisioned, you cannot expand the member switch image.

In J-Web Application package Release 14.1X53-A2, you can form a Virtual Chassis using EX4600 and EX4300 switches. When in a mixed Virtual Chassis consisting of EX4600 switches and EX4300 switches, the EX4600 switches can be the master, backup, or in the linecard role, while the EX4300 switches must be in the linecard role.

[Table 14 on page 32](#) lists the details that are displayed on each member switch.

Table 14: Details of a Virtual Chassis Member Switch

Details	Example
Model number of the member switch	EX3300
Assigned ID that applies to the entire Virtual Chassis configuration	ID 2 NOTE: If the member switch is not provisioned, the serial number of the switch is displayed instead of its ID.
Role of the member switch	Master Possible roles are: Master , Backup , or Linecard
Status of the member switch	Prsnt Possible statuses are: Prsnt , NotPrsnt , Inactive , or Unprvsnd

The status of the member switch is displayed on the image of the switch. If the member switch appears dimmed, it means the switch is not present, is inactive, or is not provisioned in the Virtual Chassis. If the member switch does not appear dimmed, it means the switch is present and is active.

[Table 15 on page 33](#) describes the possible status of a member switch.

Table 15: Status of a Member Switch in a Virtual Chassis

If the member switch is	It appears as	It means the member switch
Present	Prsnt	Has established physical and logical connections with Virtual Chassis member switches.
Not present	dimmed and NotPrsnt	Has been disconnected from the existing Virtual Chassis.
Inactive	dimmed and Inactive	Has established physical connections, but is unable to establish logical connections.
Not provisioned	dimmed and Unprvsnd	Cannot synchronize with the existing preprovisioned Virtual Chassis.

Click **Rear View** for a graphical view of the rear panel of the switch.

Click **Preferences** to choose which panels must be displayed and set the refresh interval for chassis viewer information. Click **OK** to save your changes and return to the dashboard or click **Cancel** to return to the dashboard without saving changes.



NOTE: You can drag the various panels to different locations in the J-Web window.

System Information Panel

Table 16: System Information

Field	Description
System name	Indicates the local name of the EX Series switch. The local name of the EX Series switches changes when an individual image is clicked.
Device model	Indicates the model of the EX Series switch. In a Virtual Chassis configuration, to indicate the model of a switch, click the image of that switch. NOTE: In a Virtual Chassis setup for an EX6210, EX8208, or EX8216 switch, the Device model field displays details of the master Routing Engine. To view details of a member, select it.

Table 16: System Information (*continued*)

Field	Description
Inventory details	<p>Indicates the following:</p> <ul style="list-style-type: none"> For EX3200 switches; and for EX2200, EX2200-C, EX3300, EX4200, EX4300, EX4500, EX4550, and EX4600 switches that are not configured as Virtual Chassis, the value displayed in Inventory details field is always 1 FPC. FPC is a legacy term for a slot in a large Juniper Networks chassis; which simply refers to the standalone switch. For EX2200 and EX2200-C switches configured as a Virtual Chassis, the value displayed in the Inventory details field is 1–4 FPC, with the number corresponding to the number of member switches. For EX3300 switches configured as a Virtual Chassis, the value displayed in the Inventory details field is 1–6 FPC, with the number corresponding to the number of member switches. <p>NOTE: For Junos OS Release 14.1X53-D10 and later, EX3300 switches configured as a Virtual Chassis display the value 1–10 FPC in the Inventory details field.</p> <ul style="list-style-type: none"> For EX4200, EX4500, EX4550, and EX4600 switches configured as a Virtual Chassis, the value displayed in the Inventory details field is 1–10 FPC, with the number corresponding to the number of member switches. For EX6210 switches, the values displayed in the Inventory details field are 1–2 CB and 1–9 FPC. CB, or Control Board, refers to the SRE module. FPC refers to line cards and the FPC within the CB. For an EX8208 switch, the values displayed in Inventory details field are 1–3 CB and 0–8 FPC. CB, or Control Board, refers to SRE and SF modules. FPC refers to line cards. For EX8216 switches, the values displayed in Inventory details field are 1–2 CB and 0–16 FPC. CB, or Control Board, refers to RE modules and FPC refers to line cards. For an XRE200 External Routing Engine in an EX8200 Virtual Chassis, the value displayed in Inventory details is 1 XRE. XRE refers to RE modules. For XRE200 External Routing Engines configured as a Virtual Chassis, the values displayed in Inventory details are 1–2 XRE and 0–4 LCC, where LCC refers to the EX8200 line card chassis.
Junos image	<p>Indicates the version of the Junos OS image. In a Virtual Chassis configuration, the Junos OS image of the master switch is displayed by default. To display the Junos OS image of a specific switch, click the image of that switch.</p>
Boot image	<p>Indicates the version of the boot image that is used. In a Virtual Chassis configuration, the boot image of the master switch is displayed by default. To display the boot image of a specific switch, click the image of that switch.</p>

Table 16: System Information (*continued*)

Field	Description
Device uptime	Indicates the time since the last reboot. In a Virtual Chassis configuration, to display the uptime of the specific switch, click the image of that switch.
Last configured time	Indicates the time when the switch was last configured.

Health Status Panel

Table 17: Health Status

Field	Description
EX2200, EX2200-C, EX3200, EX3300, EX4200, and EX4300 Switches	
Memory util.	<p>Indicates the memory used in the Routing Engine. In a Virtual Chassis configuration, the memory utilization value of the master Routing Engine is displayed.</p> <p>NOTE: In EX4300 and EX4600 Virtual Chassis, to display the Routing Engine memory utilization of the master or backup, click the respective image. J-Web is supported on EX4600 switches only in J-Web Application package Release 14.1X53-A2.</p>
Flash	<p>Indicates the usage and capacity of internal flash memory and any external USB flash drive.</p> <p>NOTE: In EX4300 Virtual Chassis, the flash memory utilization of the master switch is displayed by default. To display the flash memory utilization along with the internal and external flash memory utilization details for each switch or line card, mouse over individual switch or line card images.</p> <p>In EX4600 Virtual Chassis, to display the flash memory utilization along with the internal and external flash memory utilization details of each switch or line card mouse over the green-colored indicator.</p>
Temp.	<p>Indicates the chassis temperature status. Temperatures are listed in Celsius and the corresponding Fahrenheit values.</p> <p>NOTE: The Temp field is unavailable for a standalone EX2200-C switch.</p> <p>The Temp field is dynamically available for an EX2200 Virtual Chassis switch based on the model of the member clicked.</p> <p>NOTE: In EX4300 Virtual Chassis, the temperature of the master Routing Engine is displayed by default. To display the temperature of the Routing Engine of any switch, click the image of that switch.</p> <p>In EX4600 Virtual Chassis, to display the temperature of the Routing Engine of each switch, mouse over the green-colored indicator.</p>
CPU load	<p>Indicates the average CPU usage over 15 minutes. In a Virtual Chassis configuration, on loading the master or backup switch, the CPU load for that switch's Routing Engine is displayed by default. To display the CPU load for a specific switch's Routing Engine, click the image of that switch.</p>

Table 17: Health Status (*continued*)

Field	Description
Fan status	<p>Indicates the status of the fans in the fan tray. The possible values are OK, Failed, and Absent. In a Virtual Chassis configuration, the fan status of the master switch is displayed by default. To display the fan status for any switch, click the image of that switch.</p> <p>NOTE: The Fan status field is unavailable for a standalone EX2200-C switch.</p> <p>The Fan status field is dynamically available for an EX2200 Virtual Chassis switch based on the model of the member clicked.</p> <p>In EX4600 Virtual Chassis, mouse over the fan icon to display the fan status of all the switches.</p>
EX4500 and EX4550 Switches	
Memory util.	Indicates the memory used in the Routing Engine. In a Virtual Chassis configuration, the memory utilization value of the master Routing Engine is displayed.
Flash	Indicates the usage and capacity of internal flash memory and any external USB flash drive.
Temp.	Indicates the chassis temperature status. Temperatures in the dashboard are listed in Celsius and the corresponding Fahrenheit values.
	NOTE: The Temp field is unavailable for an EX4500 switch.
CPU load	Indicates the average CPU usage over 15 minutes.
Fan status	Indicates the status of the fans in the fan tray. The possible values are OK , Failed , and Absent . This field also indicates the direction of airflow of the fan tray. The possible values are Front to back and Back to front .
EX6210 Switches	
Memory util.	Indicates the memory used in the master Routing Engine. Click the backup Routing Engine to view the memory used in the backup Routing Engine.
CPU load	Indicates the average CPU usage over 15 minutes.
Flash	Indicates the usage and capacity of internal flash memory and any external USB flash drive.
Fan status	Indicates the status of the fans in the fan tray. The possible values are OK , Failed , and Absent .
EX8208 Switches	
Memory util.	Indicates the memory used in the external Routing Engine. In an EX8200 Virtual Chassis, the memory utilization value of the XRE200 External Routing Engine in the master role is displayed. Click the XRE200 External Routing Engine in the backup role to view the memory used in the backup external Routing Engine.
CPU load	Indicates the average CPU usage over 15 minutes.
Flash	Indicates the usage and capacity of internal flash memory and any external USB flash drive.
EX8216 Switches	

Table 17: Health Status (*continued*)

Field	Description
Memory util.	Indicates the memory used in the external Routing Engine. In an EX8200 Virtual Chassis, the memory utilization value of the XRE200 External Routing Engine in the master role is displayed. Click the XRE200 External Routing Engine in the backup role to view the memory used in the backup external Routing Engine.
CPU load	Indicates the average CPU usage over 15 minutes.
Flash	Indicates the usage and capacity of internal flash memory and any external USB flash drive.
XRE200 External Routing Engines	
Memory util.	Indicates the memory used in the external Routing Engine. In an EX8200 Virtual Chassis, the memory utilization value of the XRE200 External Routing Engine in the master role is displayed. Click the backup XRE200 External Routing Engine to view the memory used in backup external Routing Engine.
CPU load	Indicates the average CPU usage over 15 minutes.
Flash	Indicates the usage and capacity of internal flash memory and any external USB flash drive.
Fan Status	Indicates the status of the fans in the fan tray. The possible values are OK , Failed , and Absent .

Capacity Utilization Panel

Table 18: Capacity Utilization

Field	Description
Number of active ports	Indicates the number of active ports in the switch. Configured Virtual Chassis ports (VCPs) are considered as active ports.
Total number of ports	Indicates the number of ports in the switch. NOTE: In EX3300 and EX4600 Virtual Chassis, the total number of ports of all of the switches is displayed.
Used-up MAC-Table entries	Indicates the number of MAC table entries.
Supported MAC-Table entries	Indicates the maximum number of MAC table entries permitted.
Number of VLANs configured	Indicates the number of VLANs configured. NOTE: Only tagged VLANs are counted.
Number of VLANs supported	Indicates the maximum number of VLANs supported.

Alarms Panel

Displays information about the last five alarms raised in the system. For example, if there are 5 major alarms, then details of all 5 major alarms are displayed. If there are 4 major

alarms and 3 minor alarms, then details of the 4 major alarms and 1 minor alarm are displayed. Major alarms are displayed in red and minor alarms are displayed in yellow.

In an EX8200 Virtual Chassis, the top 5 alarms for the master external Routing Engine are displayed by default. If you select an EX8200 member switch of the Virtual Chassis, the top 5 alarms for that member switch are displayed.

File System Usage

To display the file system storage details of a switch in the backup or linecard role, click the image of that switch.

Chassis Viewer

Click the **Rear View** button to see the back of the chassis image. Click the **Front View** button to see the front of the chassis image. In a Virtual Chassis configuration, the **Rear View** button is disabled if the switch is not selected.

- [Table 19 on page 38](#)—Describes the chassis viewer for EX2200 switches.
- [Table 20 on page 39](#)—Describes the chassis viewer for EX2200-C switches.
- [Table 21 on page 39](#)—Describes the chassis viewer for EX3200, EX3300, and EX4200 switches.
- [Table 22 on page 41](#)—Describes the chassis viewer for EX4300 switches.
- [Table 23 on page 42](#)—Describes the chassis viewer for EX4500 switches.
- [Table 24 on page 43](#)—Describes the chassis viewer for EX4550 switches.
- [Table 25 on page 45](#)—Describes the chassis viewer for EX4600 switches.
- [Table 26 on page 45](#)—Describes the chassis viewer for EX6210 switches.
- [Table 27 on page 46](#)—Describes the chassis viewer for EX8208 switches.
- [Table 28 on page 48](#)—Describes the chassis viewer for EX8216 switches.
- [Table 29 on page 48](#)—Describes the chassis viewer for the XRE200 External Routing Engines.

Table 19: Chassis Viewer for EX2200 Switches

Field	Description
Front View	
Interface status	<p>In the image, the following colors denote the interface status:</p> <ul style="list-style-type: none"> • Green—Interface is up and operational. • Yellow—Interface is up but is nonoperational. • Gray—Interface is down and nonoperational. <p>Mouse over the interface (port) to view more information.</p>
Rear View	

Table 19: Chassis Viewer for EX2200 Switches (*continued*)

Field	Description
Management (me0) port	The management port is used to connect the switch to a management device for out-of-band management.
Console port	The console port is used to connect the switch to a management console or to a console server. (You might do this for initial switch configuration.)
USB port	Indicates the USB port for the switch. NOTE: We recommend that you use USB flash drives purchased from Juniper Networks for your EX Series switch.
Fan tray	Mouse over the fan tray icon to display name, status, and description information.
Power supply	Mouse over the power outlet icon to display name, status, and description information.

Table 20: Chassis Viewer for EX2200-C Switches

Field	Description
Front View	
Interface status	In the image, the following colors denote the interface status: <ul style="list-style-type: none"> Green—Interface is up and operational. Yellow—Interface is up but is nonoperational. Gray—Interface is down and nonoperational. Mouse over the interface (port) to view more information.
Management (me0) port	The management port is used to connect the switch to a management device for out-of-band management.
Console port	The console port is used to connect the switch to a management console or to a console server. (You might do this for initial switch configuration.)
USB port	Indicates the USB port for the switch. NOTE: We recommend that you use USB flash drives purchased from Juniper Networks for your EX Series switch.
Rear View	
Power supply	Mouse over the power outlet icon to display name, status, and description information.

Table 21: Chassis Viewer for EX3200, EX3300, and EX4200 Switches

Field	Description
Front View	

Table 21: Chassis Viewer for EX3200, EX3300, and EX4200 Switches (*continued*)

Field	Description
Interface status	<p>In the image, the following colors denote the interface status:</p> <ul style="list-style-type: none"> Green—Interface is up and operational. Yellow—Interface is up but is nonoperational. Gray—Interface is down and nonoperational. <p>Mouse over the interface (port) to view more information.</p> <p>For a Virtual Chassis configuration, select the switch to view the interface status.</p> <p>If an SFP+ uplink module is installed in the switch, mouse over the port icon to display whether the module is configured to operate in 1-gigabit mode or in 10-gigabit mode. If the module is configured to operate in 1-gigabit mode, the tool tip information is displayed for all 4 ports. If the module is configured to operate in 10-gigabit mode, the tool tip information is displayed only for 2 ports.</p> <p>On an EX3300 switch with the 4x GE/XE SFP+ module, mouse over the port icon to display whether the module is configured to operate in 1-gigabit mode or 10-gigabit mode.</p> <p>For SFP, SFP+, and XFP ports, the interfaces appear dimmed if no transceiver is inserted. The chassis viewer displays Transceiver not plugged-in when you mouse over the port icon.</p>
LCD panel	LCD panel configured for the LEDs on the ports. Mouse over the icon to view the current character display.
Rear View of the EX3200 Switch	
Management (me0) port	The management port is used to connect the switch to a management device for out-of-band management.
Console port	The console port is used to connect the switch to a management console or to a console server. (You might do this for initial switch configuration.)
USB port	<p>Indicates the USB port for the switch.</p> <p>NOTE: We recommend that you use USB flash drives purchased from Juniper Networks for your EX Series switch.</p>
Fan tray	Mouse over the fan tray icon to display name, status, and description information.
Power supply	Mouse over the power supply icon to display name, status, and description information.
Rear View of the EX3300 and EX4200 Switch	
Fan tray	Mouse over the fan tray icon to display name, status, and description information. For a Virtual Chassis, the status of the fans of the selected member switch is displayed.
Virtual Chassis port	<p>Displayed only when EX4200 switches are configured as a Virtual Chassis. The following colors denote the Virtual Chassis port (VCP) status:</p> <ul style="list-style-type: none"> Green—VCP is up and operational. Yellow—VCP is up but is nonoperational. Gray—VCP is down and nonoperational.

Table 21: Chassis Viewer for EX3200, EX3300, and EX4200 Switches (*continued*)

Field	Description
USB port	Indicates the USB port for the switch. NOTE: We recommend that you use USB flash drives purchased from Juniper Networks for your EX Series switch.
Management (me0) port	The management port is used to connect the switch to a management device for out-of-band management.
Console port	The console port is used to connect the switch to a management console or to a console server. (You might do this for initial switch configuration.)
Power supplies	Mouse over the power supply icons to display name, status, and description information.

Table 22: Chassis Viewer for EX4300 Switches

Field	Description
Front View	
Interface status	In the image, the colors listed below denote the interface status for both copper and fiber media type of ports: <ul style="list-style-type: none"> Green—Interface is up and operational. Yellow—Interface is up but is nonoperational. Gray—Interface is down and nonoperational. Mouse over the interface (port) to view more information.
LCD panel	LCD panel configured for the LEDs on the ports. Mouse over the icon to view the current character display.
Mini USB console	The mini console port is used to connect the switch to the management console.
PIC 2 slot	You can install an uplink module in the PIC 2 slot. Mouse over the ports in the module to view the details of the ports in module. 24-port and 48-port EX4300 switches support the 4-port 10-Gigabit SFP+ uplink module. EX4300-32F switches support the 2-port 40-Gigabit QSFP+ uplink module and the 8-port 10-Gigabit SFP+ uplink module. When you install a transceiver in the port, the following colors denote the interface status: <ul style="list-style-type: none"> Green—Interface is up and operational. Yellow—Interface is up but is not operational. Gray—Interface is down and not operational.

NOTE: In EX4300 switches the LEDs are seen in the front panel, these are not active.

Rear View of the EX4300 Switch

Management port	The management port is used to connect the switch to a management device for out-of-band management.
-----------------	--

Table 22: Chassis Viewer for EX4300 Switches (*continued*)

Field	Description
Console port	The Console port (RJ-45) is used to connect the switch to a management console or to a console server.
USB port	Indicates the USB port for the switch. NOTE: We recommend that you use USB flash drives purchased from Juniper Networks for your EX Series switch.
Fan tray	Mouse over the fan tray icons to display name, status, and description information.
Power supplies	Mouse over the power supply icons to display name, status, and description information.
PIC 1 slot	The rear panel of a 24-port and a 48-port EX4300 switch has four (built-in) 40-Gigabit QSFP+ ports, and the rear panel of an EX4300-32F switch has two (built-in) 40-Gigabit QSFP+ ports, in which you can install QSFP+ transceivers. Mouse over the ports to view the details of the ports. After you install a transceiver in the port, the following colors denote the interface status: <ul style="list-style-type: none"> Green—Interface is up and operational. Yellow—Interface is up but is not operational. Gray—Interface is down and not operational. For QSFP+ ports, the interfaces appear dimmed if no transceiver is inserted. The chassis viewer displays Transceiver not plugged in when you mouse over the port. When a QSFP+ port is configured as a Virtual Chassis Port (VCP), the following colors denote the VCP status: <ul style="list-style-type: none"> Green—VCP is up and operational. Yellow—VCP is up but is not operational. Gray—VCP is down and not operational.

Table 23: Chassis Viewer for EX4500 Switches

Field	Description
Front View	
Interface status	In the image, the colors listed below denote the interface status: <ul style="list-style-type: none"> Green—Interface is up and operational. Yellow—Interface is up but is nonoperational. Gray—Interface is down and nonoperational. Mouse over the interface (port) to view more information. For a Virtual Chassis configuration, select the switch to view the interface status. If an SFP+ uplink module is installed in the switch, mouse over the interface (ports) on the module for more information. For SFP and SFP+ ports, the interfaces appear dimmed if no transceiver is inserted. The chassis viewer displays Transceiver not plugged-in when you mouse over the port icon.

Table 23: Chassis Viewer for EX4500 Switches (*continued*)

Field	Description
LCD panel	LCD panel configured for the LEDs on the ports. Mouse over the icon to view the current character display.
Console port	The console port is used to connect the switch to a management console or to a console server.
Management (me0) port	The management port is used to connect the switch to a management device for out-of-band management. Use this port for initial switch configuration.
USB port	Indicates the USB port for the switch. NOTE: We recommend that you use USB flash drives purchased from Juniper Networks for your EX Series switch.
Rear View of the EX4500 Switch	
Fan tray	Mouse over the fan tray icon to display status of the fans and airflow direction information. For a Virtual Chassis, the status of the fans of the selected member switch is displayed.
Virtual Chassis port	Displayed only when switches are configured as a Virtual Chassis. The colors listed below denote the Virtual Chassis port (VCP) status: <ul style="list-style-type: none"> • Green—VCP is up and operational. • Yellow—VCP is up but is nonoperational. • Gray—VCP is down and nonoperational.
Power supplies	Mouse over the power supply icons to display name, status, and description information.
Intraconnect module	Mouse over the module to display details of the intraconnect module. The intraconnect module helps the switch achieve line rate on all its ports.
Virtual Chassis module	Mouse over to display details of the switches in the Virtual Chassis configuration.

Table 24: Chassis Viewer for EX4550 Switches

Field	Description
Front View	

Table 24: Chassis Viewer for EX4550 Switches (*continued*)

Field	Description
Interface status	<p>In the image, the colors listed below denote the interface status:</p> <ul style="list-style-type: none"> Green—Interface is up and operational. Yellow—Interface is up but is nonoperational. Gray—Interface is down and nonoperational. <p>Mouse over the interface (port) to view more information.</p> <p>For a Virtual Chassis configuration, select the switch to view the interface status.</p> <p>If an expansion module or a Virtual Chassis module is installed in the switch, mouse over the interface (ports) on the module for more information.</p> <p>On an EX4550-32F switch, for SFP and SFP+ ports, the interfaces appear dimmed if no transceiver is inserted. The chassis viewer displays Transceiver (1G/10G) not plugged in when you mouse over the port icon.</p>
LCD panel	LCD panel configured for the LEDs on the ports. Mouse over the icon to view the current character display.
Console port	The console port is used to connect the switch to a management console or to a console server.
Mini Console port	The mini console port is used to connect the switch to the management console.
Management (me0) port	The management port is used to connect the switch to a management device for out-of-band management. Use this port for initial switch configuration.
PIC1 slot	You can insert an uplink module or a Virtual Chassis module in the PIC1 slot. Mouse over to display the details of the module inserted (uplink or Virtual Chassis).
USB port	<p>Indicates the USB port for the switch.</p> <p>NOTE: We recommend that you use USB flash drives purchased from Juniper Networks for your EX Series switch.</p>
Rear View of the EX4550 Switch	
Fan tray	Mouse over the fan tray icon to display the status of the fans and airflow direction information. For a Virtual Chassis, the status of the fans of the selected member switch is displayed.
Virtual Chassis port	<p>Displayed only when switches are configured as a Virtual Chassis. In the image, the colors listed below denote the Virtual Chassis port (VCP) status:</p> <ul style="list-style-type: none"> Green—VCP is up and operational. Yellow—VCP is up but is nonoperational. Gray—VCP is down and nonoperational.
Power supplies	Mouse over the power supply icons to display name, status, and description information.
PIC2 slot	You can insert an uplink module or a Virtual Chassis module into the PIC2 slot. Mouse over to display the details of the module inserted (uplink or Virtual Chassis).

Table 25: Chassis Viewer for EX4600 Switches

Field	Description
Front View	
NOTE: J-Web is supported on EX4600 switches only in J-Web Application package Release 14.1X53-A2.	
Interface status	<p>In the image, the colors listed below denote the interface status for both copper and fiber media type of ports:</p> <ul style="list-style-type: none"> • Green—Interface is up and operational. • Yellow—Interface is up but is nonoperational. • Gray—Interface is down and nonoperational. <p>Mouse over the interface (port) to view more information.</p>
PIC 1 and PIC 2 slots	<p>You can install an expansion module in the PIC 1 and PIC 2 slots. If you have installed an expansion module, mouse over the ports in the module to view the details of the ports in module.</p> <p>When you install a transceiver in the port, the following colors denote the interface status:</p> <ul style="list-style-type: none"> • Green—Interface is up and operational. • Yellow—Interface is up but is not operational. • Gray—Interface is down and not operational.
NOTE:	
<ul style="list-style-type: none"> • In EX4600 switches the LEDs are seen in the front panel; these are not active. • In EX4600 switches there is no LCD panel. 	
Rear View of the EX4600 Switch	
Management port	The management ports (RJ-45 and SFP) is used to connect the switch to a management device for out-of-band management.
Console port	The Console port (RJ-45) is used to connect the switch to a management console or to a console server.
USB port	<p>Indicates the USB port for the switch.</p> <p>NOTE: We recommend that you use USB flash drives purchased from Juniper Networks for your EX Series switch.</p>
Fan tray	Mouse over the fan tray icons to display name, status, and description information.
Power supplies	Mouse over the power supply icons to display name, status, and description information.

Table 26: Chassis Viewer for EX6210 Switches

Field	Description
Front View	
Temperature	Mouse over the temperature icon to display the temperature of the CB or line card.

Table 26: Chassis Viewer for EX6210 Switches (*continued*)

Field	Description
Interface status	<p>Select the CB or line card.</p> <p>In the image, the colors listed below denote the interface status:</p> <ul style="list-style-type: none"> • Green—Interface is up and operational. • Yellow—Interface is up but is nonoperational. • Gray—Interface is down and nonoperational. <p>Mouse over the interface (port) to view more information.</p> <p>You can view status for the following ports on the SRE module:</p> <ul style="list-style-type: none"> • USB port—Indicates the USB port for the switch. <p>NOTE: We recommend that you use USB flash drives purchased from Juniper Networks for your EX Series switch.</p> <ul style="list-style-type: none"> • Management (me0) port—The management port is used to connect the switch to a management device for out-of-band management. There are 2 management ports: fiber and copper. The same status is displayed for both the me0 ports. • Console port—The console port is used to connect the switch to a management console or to a console server. (You might do this for initial switch configuration.) <p>CBs support 4 SFP+ uplink ports. Mouse over the interface on the CB for more information.</p> <p>For SFP and SFP+ ports, the interfaces appear dimmed if no transceiver is inserted. The chassis viewer displays Transceiver not plugged-in when you mouse over the port icon.</p>
Power supplies	Mouse over the power supply icons to display name, status, and description information.
LCD panel	LCD panel configured for the LEDs on the ports. Mouse over the icon to view the current character display of the master Routing Engine. The EX6210 switch has 2 LCD panels, one for each Routing Engine. The backup Routing Engine LCD displays Backup .
Rear View of the EX6210 Switch	
Fan tray	Mouse over the fan tray icon to display information regarding the cooling fans.

Table 27: Chassis Viewer for EX8208 Switches

Field	Description
Front View	

Table 27: Chassis Viewer for EX8208 Switches (*continued*)

Field	Description
Interface status	<p>In the image, click any line card, SRE module, or SF module to view the front view of the selected component. In the image, the colors listed below denote the interface status:</p> <ul style="list-style-type: none"> Green—Interface is up and operational. Yellow—Interface is up but is nonoperational. Gray—Interface is down and nonoperational. <p>Mouse over the interface (port) to view more information.</p> <p>You can view status for the following ports on the SRE module:</p> <ul style="list-style-type: none"> USB port—Indicates the USB port for the switch. <p>NOTE: We recommend that you use USB flash drives purchased from Juniper Networks for your EX Series switch.</p> <ul style="list-style-type: none"> Auxiliary port—This port is unavailable. Management (me0) port—The management port is used to connect the switch to a management device for out-of-band management. Console port—The console port is used to connect the switch to a management console or to a console server. (You might do this for initial switch configuration.) <p>Because the SF module has no ports, no status information is displayed.</p>
Slot numbers	<p>Slots on the switch are labeled, from the top of the switch down:</p> <ul style="list-style-type: none"> 0–3 (line cards) SRE0, SF, SRE1 (SRE and SF modules) 4–7 (line cards)
Temperature	<p>The active slots contain a gray temperature icon. Mouse over the icon to display temperature information for the slot.</p>
Fan status	<p>Mouse over the fan tray icon to display name, status, and description information.</p>
Power supplies	<p>Mouse over the power supply icons to display name, status, and description information.</p>
LCD panel	<p>LCD panel configured for the LEDs on the ports. Mouse over the icon to view the current character display.</p>
Rear View	<p>The EX8208 switch does not have any components on the rear of the chassis.</p>

Table 28: Chassis Viewer for EX8216 Switches

Field	Description
Front View	
Interface status	<p>In the image, click any line card or RE module to display the front view of the selected component. In the image, the colors listed below denote the interface status:</p> <ul style="list-style-type: none"> Green—Interface is up and operational. Yellow—Interface is up but is nonoperational. Gray—Interface is down and nonoperational. <p>Mouse over the interface (port) to view more information.</p> <p>You can view status for the following ports on the RE module:</p> <ul style="list-style-type: none"> USB port—Indicates the USB port for the switch. <p>NOTE: We recommend that you use USB flash drives purchased from Juniper Networks for your EX Series switch.</p> <ul style="list-style-type: none"> Auxiliary port—This port is unavailable. Management (me0) port—The management port is used to connect the switch to a management device for out-of-band management. Console port—The console port is used to connect the switch to a management console or to a console server. (You might do this for initial switch configuration.)
Slot numbers	<p>Slots on the switch are labeled, from the top of the switch down:</p> <ul style="list-style-type: none"> RE0 (RE module) RE1 (RE module) 0–15 (line cards)
Temperature	The active slots contain a gray temperature icon. Mouse over the icon to display temperature information for the slot.
Fan status	Mouse over the fan tray icon to display consolidated information about the fans.
Power supplies	Mouse over the power supply icons to display name, status, and description information.
LCD panel	LCD panel configured for the LEDs on the ports. Mouse over the icon to view the current character display.
Rear View	
SF modules	Mouse over the SF module icons in their respective slots to display information. Slots are numbered SF7–SF0, from left to right.

Table 29: Chassis Viewer for XRE200 External Routing Engines

Field	Description
Front View	

Table 29: Chassis Viewer for XRE200 External Routing Engines (*continued*)

Field	Description
Interface status	<p>In the image, the colors listed below denote the interface status:</p> <ul style="list-style-type: none"> • Green—Interface is up and operational. • Yellow—Interface is up but is nonoperational. • Gray—Interface is down and nonoperational. <p>Mouse over the interface (port) to view more information.</p> <p>For a Virtual Chassis configuration, select the switch to view the interface status.</p>
Console port	The console port is used to connect the switch to a management console or to a console server.
Management (me0) port	The management port is used to connect the switch to a management device for out-of-band management. Use this port for initial switch configuration.
Virtual Chassis port	<p>In the image, the colors listed below denote the Virtual Chassis port (VCP) status:</p> <ul style="list-style-type: none"> • Green—VCP is up and operational. • Yellow—VCP is up but is nonoperational. • Gray—VCP is down and nonoperational. <p>Mouse over the interface (port) to view more information.</p>
LCD panel	LCD panel configured for the LEDs on the ports. Mouse over the icon to view the current character display.
Temperature	The active slots contain a gray temperature icon. Mouse over the icon to display temperature information for the slot.
USB port	<p>Indicates the USB port for the switch.</p> <p>NOTE: We recommend that you use USB flash drives purchased from Juniper Networks for your EX Series switch.</p>
PIC1 slot	You can install a Virtual Chassis module in the PIC1 slot. Mouse over the Virtual Chassis ports to display the port status details.
PIC2 slot	You can install a Virtual Chassis module in the PIC2 slot. Mouse over the Virtual Chassis ports to display the port status details.
Rear View of the XRE200 External Routing Engine	
Fan modules	Mouse over the fan modules to display status of the fans and airflow direction information. For a Virtual Chassis, the status of the fans of the selected member switch is displayed.
Power supplies	Mouse over the power supply icons to display name, status, and description information.

Release History Table

Release	Description
14.1X53-D10	For Junos OS Release 14.1X53-D10 and later, EX3300 switches configured as a Virtual Chassis display the value 1–10 FPC in the Inventory details field.
14.1X53-A2	In J-Web Application package Release 14.1X53-A2, you can form a Virtual Chassis using EX4600 and EX4300 switches.
14.1X53-A2	J-Web is supported on EX4600 switches only in J-Web Application package Release 14.1X53-A2.

Related Documentation

- [J-Web User Interface for EX Series Switches Overview](#)
- [EX2200 Switches Hardware Overview](#)
- [EX2300 Switches Hardware Overview on page 3](#)
- [EX3200 Switches Hardware Overview](#)
- [EX3300 Switches Hardware Overview](#)
- [EX4200 Switches Hardware Overview](#)
- [EX4300 Switches Hardware Overview](#)
- [EX4500 Switches Hardware Overview](#)
- [EX6210 Switch Hardware Overview](#)
- [EX8208 Switch Hardware Overview](#)
- [EX8216 Switch Hardware Overview](#)
- [Checking Active Alarms with the J-Web Interface on page 196](#)
- [XRE200 External Routing Engine Hardware Guide](#)

PART 2

Site Planning, Preparation, and Specifications

- [Preparation Overview on page 53](#)
- [Power Specifications and Requirements on page 69](#)
- [Transceiver and Cable Specifications on page 75](#)
- [Pinout Specifications on page 85](#)
- [Planning the Virtual Chassis on page 95](#)

CHAPTER 6

Preparation Overview

- Site Preparation Checklist for EX2300 Switches on page 53
- Environmental Requirements and Specifications for EX Series Switches on page 55
- General Site Guidelines on page 59
- Site Electrical Wiring Guidelines on page 59
- Chassis Physical Specifications for EX2300 Switches on page 60
- Rack Requirements on page 61
- Requirements for Mounting an EX2300 Switch On or Under a Desk or Other Level Surface or On a Wall on page 62
- Cabinet Requirements on page 63
- Clearance Requirements for Airflow and Hardware Maintenance for EX2300 Switches on page 64

Site Preparation Checklist for EX2300 Switches

The checklist in [Table 30 on page 53](#) summarizes the tasks you need to perform when preparing a site for EX2300 switch installation.

Table 30: Site Preparation Checklist

Item or Task	For More Information	Performed by	Date
Environment			
Verify that environmental factors such as temperature and humidity do not exceed switch tolerances.	"Environmental Requirements and Specifications for EX Series Switches" on page 55		
Power			
Measure the distance between external power sources and the switch installation site.			
Locate sites for connection of system grounding.			
Calculate the power consumption and requirements.	"Power Specifications for EX2300 Switches" on page 69		

Table 30: Site Preparation Checklist (*continued*)

Item or Task	For More Information	Performed by	Date
Hardware Configuration			
Choose the number and types of switches you want to install.	"EX2300 Switches Hardware Overview" on page 3		
Rack or Cabinet			
Verify that your rack or cabinet meets the minimum requirements for the installation of the switch.	"Rack Requirements" on page 61 "Cabinet Requirements" on page 63		
Plan rack or cabinet location, including required space clearances.	"Clearance Requirements for Airflow and Hardware Maintenance for EX2300 Switches" on page 64		
Secure the rack or cabinet to the floor and building structure.			
Desk or Wall			
Verify that the wall meets the minimum requirements for the installation of the switch.	"Requirements for Mounting an EX2300 Switch On or Under a Desk or Other Level Surface or On a Wall" on page 62		
Verify that there is appropriate clearance in your selected location.	"Clearance Requirements for Airflow and Hardware Maintenance for EX2300 Switches" on page 64		
Cables			
Acquire cables and connectors:			
<ul style="list-style-type: none"> Determine the number of cables needed based on your planned configuration. Review the maximum distance allowed for each cable. Choose the length of cable based on the distance between the hardware components being connected. 			
Plan the cable routing and management.			

Related Documentation

- [General Safety Guidelines and Warnings on page 213](#)
- [General Site Guidelines on page 59](#)
- [Installing and Connecting an EX2300 Switch on page 103](#)
- [Mounting an EX2300 Switch on page 104](#)

Environmental Requirements and Specifications for EX Series Switches

The switch must be installed in a rack or cabinet housed in a dry, clean, well-ventilated, and temperature-controlled environment.

Ensure that these environmental guidelines are followed:

- The site must be as dust-free as possible, because dust can clog air intake vents and filters, reducing the efficiency of the switch cooling system.
- Maintain ambient airflow for normal switch operation. If the airflow is blocked or restricted, or if the intake air is too warm, the switch might overheat, leading to the switch temperature monitor shutting down the switch to protect the hardware components.

Table 31 on page 55 provides the required environmental conditions for normal switch operation.

Table 31: EX Series Switch Environmental Tolerances

Switch or device	Environment Tolerance			
	Altitude	Relative Humidity	Temperature	Seismic
EX2200-C	No performance degradation up to 5,000 feet (1524 meters)	Normal operation ensured in the relative humidity range 10% through 85% (noncondensing)	Normal operation ensured in the temperature range 32 °F (0 °C) through 104 °F (40 °C) at altitudes up to 5,000 ft (1,524 m). For information about extended temperature SFP transceivers supported on EX2200 switches, see <i>Pluggable Transceivers Supported on EX2200 Switches</i> .	Complies with Zone 4 earthquake requirements as per GR-63, Issue 4.
EX2200 (except EX2200-C switches)	No performance degradation up to 10,000 feet (3048 meters)	Normal operation ensured in the relative humidity range 10% through 85% (noncondensing)	Normal operation ensured in the temperature range 32 °F (0 °C) through 113 °F (45 °C)	Complies with Zone 4 earthquake requirements as per GR-63, Issue 4.
EX2300-C	No performance degradation up to 5,000 feet (1524 meters)	Normal operation ensured in the relative humidity range 10% through 85% (noncondensing)	Normal operation ensured in the temperature range 32 °F (0 °C) through 104 °F (40 °C)	Complies with Zone 4 earthquake requirements as per GR-63, Issue 4.
EX2300 (except EX2300-C switches)	No performance degradation up to 13,000 feet (3048 meters) at 104 °F (40 °C) as per GR-63	Normal operation ensured in the relative humidity range 10% through 85% (noncondensing)	Normal operation ensured in the temperature range 32 °F (0 °C) through 113 °F (45 °C)	Complies with Zone 4 earthquake requirements as per GR-63, Issue 4.

Table 31: EX Series Switch Environmental Tolerances (*continued*)

Switch or device	Environment Tolerance			
	Altitude	Relative Humidity	Temperature	Seismic
EX3200	No performance degradation up to 10,000 feet (3048 meters)	Normal operation ensured in the relative humidity range 10% through 85% (noncondensing)	Normal operation ensured in the temperature range 32 °F (0 °C) through 113 °F (45 °C)	Complies with Zone 4 earthquake requirements as per GR-63, Issue 4.
EX3300	No performance degradation up to 10,000 feet (3048 meters)	Normal operation ensured in the relative humidity range 10% through 85% (noncondensing)	Normal operation ensured in the temperature range 32 °F (0 °C) through 113 °F (45 °C)	Complies with Zone 4 earthquake requirements as per GR-63, Issue 4.
EX3400	No performance degradation up to 10,000 feet (3048 meters)	Normal operation ensured in the relative humidity range 10% through 85% (noncondensing)	Normal operation ensured in the temperature range 32 °F (0 °C) through 113 °F (45 °C)	Complies with Zone 4 earthquake requirements as per GR-63, Issue 4.
EX4200	No performance degradation up to 10,000 feet (3048 meters)	Normal operation ensured in the relative humidity range 10% through 85% (noncondensing)	Normal operation ensured in the temperature range 32 °F (0 °C) through 113 °F (45 °C)	Complies with Zone 4 earthquake requirements as per GR-63, Issue 4.
EX4300	No performance degradation up to 10,000 feet (3048 meters)	Normal operation ensured in the relative humidity range 10% through 85% (noncondensing)	Normal operation ensured in the temperature range 32 °F (0 °C) through 113 °F (45 °C)	Complies with Zone 4 earthquake requirements as per GR-63, Issue 4.
EX4500	No performance degradation up to 10,000 feet (3048 meters)	Normal operation ensured in the relative humidity range 10% through 85% (noncondensing)	Normal operation ensured in the temperature range 32 °F (0 °C) through 113 °F (45 °C)	Complies with Zone 4 earthquake requirements as per GR-63, Issue 4.
EX4550	No performance degradation up to 10,000 feet (3048 meters)	Normal operation ensured in the relative humidity range 10% through 85% (noncondensing)	<ul style="list-style-type: none"> • EX4550-32F switches—Normal operation ensured in the temperature range 32 °F (0 °C) through 113 °F (45 °C) • EX4550-32T switches—Normal operation is ensured in the temperature range 32 °F through 104 °F (40 °C) 	Complies with Zone 4 earthquake requirements as per GR-63, Issue 4.

Table 31: EX Series Switch Environmental Tolerances (*continued*)

Switch or device	Environment Tolerance			
	Altitude	Relative Humidity	Temperature	Seismic
EX4600	No performance degradation to 6,562 feet (2000 meters)	<p>Normal operation ensured in the relative humidity range 5% through 90%, noncondensing</p> <ul style="list-style-type: none"> Short-term operation ensured in the relative humidity range 5% through 93%, noncondensing <p>NOTE: As defined in NEBS GR-63-CORE, Issue 4, short-term events can be up to 96 hours in duration but not more than 15 days per year.</p>	<ul style="list-style-type: none"> Normal operation ensured in the temperature range 32 °F (0 °C) through 113 °F (45 °C) Nonoperating storage temperature in shipping container: -40° F (-40° C) through 158° F (70° C) 	Designed to comply with Zone 4 earthquake requirements per NEBS GR-63-CORE, Issue 4.
EX6210	No performance degradation up to 10,000 feet (3048 meters)	Normal operation ensured in the relative humidity range 10% through 85% (noncondensing)	Normal operation is ensured in the temperature range 32° F (0° C) through 104° F (40° C)	Complies with Zone 4 earthquake requirements as per GR-63, Issue 4.
EX8208	No performance degradation up to 10,000 feet (3048 meters)	Normal operation ensured in the relative humidity range 10% through 85% (noncondensing)	Normal operation is ensured in the temperature range 32° F (0° C) through 104° F (40° C)	Complies with Zone 4 earthquake requirements as per GR-63, Issue 4.
EX8216	No performance degradation up to 10,000 feet (3048 meters)	Normal operation ensured in the relative humidity range 10% through 85% (noncondensing)	Normal operation is ensured in the temperature range 32° F (0° C) through 104° F (40° C)	Complies with Zone 4 earthquake requirements as per GR-63, Issue 4.
EX9204	No performance degradation up to 10,000 feet (3048 meters)	Normal operation ensured in the relative humidity range 5% through 90% (noncondensing)	<p>Normal operation is ensured in the temperature range 32° F (0° C) through 104° F (40° C)</p> <p>Nonoperating storage temperature in shipping container: -40° F (-40° C) to 158° F (70° C)</p>	Complies with Zone 4 earthquake requirements as per GR-63.
EX9208	No performance degradation up to 10,000 feet (3048 meters)	Normal operation ensured in the relative humidity range 5% through 90% (noncondensing)	<p>Normal operation is ensured in the temperature range 32° F (0° C) through 104° F (40° C)</p> <p>Nonoperating storage temperature in shipping container: -40° F (-40° C) to 158° F (70° C)</p>	Complies with Zone 4 earthquake requirements as per GR-63.

Table 31: EX Series Switch Environmental Tolerances (*continued*)

Switch or device	Environment Tolerance			
	Altitude	Relative Humidity	Temperature	Seismic
EX9214	No performance degradation up to 10,000 feet (3048 meters)	Normal operation ensured in the relative humidity range 5% through 90% (noncondensing)	Normal operation is ensured in the temperature range 32° F (0° C) through 104° F (40° C) Nonoperating storage temperature in shipping container: -40° F (-40° C) through 158° F (70° C)	Complies with Zone 4 earthquake requirements as per GR-63.
EX9251 The maximum thermal output is 1705 BTU/hour (500 W).	No performance degradation up to 10,000 ft (3048 m)	Normal operation ensured in relative humidity range of 5% to 90%, noncondensing	Normal operation ensured in temperature range of 32° F (0° C) to 104° F (40° C) Nonoperating storage temperature in shipping container: -40° F (-40° C) to 158° F (70° C)	Complies with Telcordia Technologies Zone 4 earthquake requirements
XRE200	No performance degradation up to 10,000 feet (3048 meters)	Normal operation ensured in the relative humidity range 10% through 85% (noncondensing)	Normal operation ensured in the temperature range 41° F (5° C) through 104° F (40° C)	Complies with Zone 4 earthquake requirements as per GR-63, Issue 4.



NOTE: Install EX Series switches only in restricted areas, such as dedicated equipment rooms and equipment closets, in accordance with Articles 110–16, 110–17, and 110–18 of the National Electrical Code, ANSI/NFPA 70.

Related Documentation

- [Clearance Requirements for Airflow and Hardware Maintenance for EX2200 Switches](#)
- [Clearance Requirements for Airflow and Hardware Maintenance for EX2300 Switches on page 64](#)
- [Clearance Requirements for Airflow and Hardware Maintenance for EX3200 Switches](#)
- [Clearance Requirements for Airflow and Hardware Maintenance for EX3300 Switches](#)
- [Clearance Requirements for Airflow and Hardware Maintenance for EX3400 Switches](#)
- [Clearance Requirements for Airflow and Hardware Maintenance for EX4200 Switches](#)
- [Clearance Requirements for Airflow and Hardware Maintenance for EX4300 Switches](#)
- [Clearance Requirements for Airflow and Hardware Maintenance for an EX4600 Switch](#)
- [Clearance Requirements for Airflow and Hardware Maintenance for an EX Series Redundant Power System](#)
- [Clearance Requirements for Airflow and Hardware Maintenance for EX4500 Switches](#)
- [Clearance Requirements for Airflow and Hardware Maintenance for EX4550 Switches](#)

- *Clearance Requirements for Airflow and Hardware Maintenance for an EX6210 Switch*
- *Clearance Requirements for Airflow and Hardware Maintenance for an EX8208 Switch*
- *Clearance Requirements for Airflow and Hardware Maintenance for an EX8216 Switch*
- *Clearance Requirements for Airflow and Hardware Maintenance for an EX9204 Switch*
- *Clearance Requirements for Airflow and Hardware Maintenance for an EX9208 Switch*
- *Clearance Requirements for Airflow and Hardware Maintenance for an EX9214 Switch*

General Site Guidelines

Efficient device operation requires proper site planning and maintenance and proper layout of the equipment, rack or cabinet (if used), and wiring closet.

To plan and create an acceptable operating environment for your device and prevent environmentally caused equipment failures:

- Keep the area around the chassis free from dust and conductive material, such as metal flakes.
- Follow prescribed airflow guidelines to ensure that the cooling system functions properly and that exhaust from other equipment does not blow into the intake vents of the device.
- Follow the prescribed electrostatic discharge (ESD) prevention procedures to prevent damaging the equipment. Static discharge can cause components to fail completely or intermittently over time.
- Install the device in a secure area, so that only authorized personnel can access the device.

Related Documentation

- [Prevention of Electrostatic Discharge Damage on page 243](#)

Site Electrical Wiring Guidelines

Table 32 on page 60 describes the factors you must consider while planning the electrical wiring at your site.



WARNING: It is particularly important to provide a properly grounded and shielded environment and to use electrical surge-suppression devices.

Table 32: Site Electrical Wiring Guidelines

Site Wiring Factor	Guidelines
Signaling limitations	<p>If your site experiences any of the following problems, consult experts in electrical surge suppression and shielding:</p> <ul style="list-style-type: none"> Improperly installed wires cause radio frequency interference (RFI). Damage from lightning strikes occurs when wires exceed recommended distances or pass between buildings. Electromagnetic pulses (EMPs) caused by lightning damage unshielded conductors and electronic devices.
Radio frequency interference	<p>To reduce or eliminate RFI from your site wiring, do the following:</p> <ul style="list-style-type: none"> Use a twisted-pair cable with a good distribution of grounding conductors. If you must exceed the recommended distances, use a high-quality twisted-pair cable with one ground conductor for each data signal when applicable.
Electromagnetic compatibility	<p>If your site is susceptible to problems with electromagnetic compatibility (EMC), particularly from lightning or radio transmitters, seek expert advice.</p> <p>Some of the problems caused by strong sources of electromagnetic interference (EMI) are:</p> <ul style="list-style-type: none"> Destruction of the signal drivers and receivers in the device Electrical hazards as a result of power surges conducted over the lines into the equipment

Related Documentation

- [General Safety Guidelines and Warnings on page 213](#)
- [General Electrical Safety Guidelines and Warnings on page 241](#)
- [Prevention of Electrostatic Discharge Damage on page 243](#)

Chassis Physical Specifications for EX2300 Switches

The EX2300 switch chassis is a rigid sheet-metal structure that houses the hardware components. [Table 5 on page 15](#) summarizes the physical specifications of the EX2300 switch chassis.

Table 33: Physical Specifications of the EX2300 Switch Chassis

Description	EX2300-C Value	EX2300 Value
Chassis height	1.72 in. (4.36 cm)	<ul style="list-style-type: none"> All models except EX2300-24MP and EX2300-48MP—1.75 in. (4.45 cm) EX2300-24MP and EX2300-48MP models—1.7 in. (4.33 cm)

Table 33: Physical Specifications of the EX2300 Switch Chassis (*continued*)

Description	EX2300-C Value	EX2300 Value
Chassis width	<ul style="list-style-type: none"> 10.98 in. (27.9 cm) 18.86 in. (47.9 cm) with mounting brackets attached 	<ul style="list-style-type: none"> All models except EX2300-24MP and EX2300-48MP <ul style="list-style-type: none"> 17.4 in. (44.19 cm) 19 in. (48.26 cm) with mounting brackets attached EX2300-24MP and EX2300-48MP models <ul style="list-style-type: none"> 17.36 in. (44.09 cm) 18.95 in. (48.13 cm) with mounting brackets attached
Chassis depth	9.45 in. (23.8 cm)	<ul style="list-style-type: none"> All models except EX2300-24MP and EX2300-48MP <ul style="list-style-type: none"> Models without PoE capability: 10.2 in. (25.9 cm) Models with PoE capability: 12.2 in. (30.98 cm) EX2300-24MP—10 in. (25.4 cm) EX2300-48MP—14.45 in. (36.71 cm)
Weight	<ul style="list-style-type: none"> EX2300-C-12T: 5.45 lb (2.48 kg) EX2300-C-12P: 6.99 lb (3.17 kg) 	<ul style="list-style-type: none"> EX2300-24T: 7.25 lb (3.29 kg) EX2300-24P: 9.89 lb (4.49 kg) EX2300-24MP: 8.8 lb (4 kg) EX2300-24T-DC: 7.83 lb (3.55 kg) EX2300-48T: 8.28 lb (3.76 kg) EX2300-48P: 11.06 lb (5.02 kg) EX2300-48MP: 14.33 lb (6.5 kg)

- Related Documentation**
- [Rack Requirements on page 61](#)
 - [Cabinet Requirements on page 63](#)
 - [Mounting an EX2300 Switch on page 104](#)
 - [Installing and Connecting an EX2300 Switch on page 103](#)

Rack Requirements

You can mount the device on two-post racks or four-post racks.

Rack requirements consist of:

- Rack type
- Mounting bracket hole spacing

- Rack size and strength
- Rack connection to the building structure

Table 34 on page 62 provides the rack requirements and specifications.

Table 34: Rack Requirements and Specifications

Rack Requirement	Guidelines
Rack type	<p>You can mount the device on a rack that provides bracket holes or hole patterns spaced at 1 U (1.75 in. or 4.45 cm) increments and meets the size and strength requirements to support the weight.</p> <p>A U is the standard rack unit defined by the Electronics Industry Association.</p>
Mounting bracket hole spacing	The holes in the mounting brackets are spaced at 1 U (1.75 in. or 4.45 cm), so that the device can be mounted in any rack that provides holes spaced at that distance.
Rack size and strength	<ul style="list-style-type: none"> • Ensure that the rack complies with the size and strength standards of a 19-in. rack as defined by the Electronics Industry Association. • Ensure that the rack rails are spaced widely enough to accommodate the external dimensions of the device chassis. The outer edges of the front-mounting brackets extend the width of the chassis to 19 in. (48.2 cm). • The rack must be strong enough to support the weight of the device. • Ensure that the spacing of rails and adjacent racks provides for proper clearance around the device and rack.
Rack connection to building structure	<ul style="list-style-type: none"> • Secure the rack to the building structure. • If earthquakes are a possibility in your geographical area, secure the rack to the floor. • Secure the rack to the ceiling brackets as well as wall or floor brackets for maximum stability.

Related Documentation • [Rack-Mounting and Cabinet-Mounting Warnings on page 224](#)

Requirements for Mounting an EX2300 Switch On or Under a Desk or Other Level Surface or On a Wall

You can mount the switch on a desk or other level surface. You can mount the EX2300-C switch under a desk or other level surface. You can mount EX2300 switches except the EX2300-24MP and EX2300-48MP models on a wall. When choosing a location, allow at least 6 in. (15.2 cm) of clearance between the front and back of the chassis and adjacent equipment or walls.

Ensure that the wall onto which the switch is installed is stable and securely supported.

If you are mounting the switch in sheetrock (wall board with a gypsum plaster core) or in wall board not backed by wall studs, use hollow wall anchors capable of supporting the combined weight of two fully loaded chassis. Insert the screws into wall studs wherever possible to provide added support for the chassis.

Use the wall-mount kit from Juniper Networks to mount the switch on a wall. The wall-mount kit is not part of the standard package and must be ordered separately.

- Related Documentation**
- [Clearance Requirements for Airflow and Hardware Maintenance for EX2300 Switches on page 64](#)
 - [Mounting an EX2300 Switch on a Desk or Other Level Surface on page 105](#)
 - [Mounting an EX2300-C Switch Under a Desk or Other Level Surface by Using Screws on page 107](#)
 - [Mounting an EX2300 Switch on a Wall on page 118](#)

Cabinet Requirements

You can mount the device in a cabinet that contains a 19-in. rack.

Cabinet requirements consist of:

- Cabinet size
- Clearance requirements
- Cabinet airflow requirements

[Table 35 on page 63](#) provides the cabinet requirements and specifications.

Table 35: Cabinet Requirements and Specifications

Cabinet Requirement	Guidelines
Cabinet size	<ul style="list-style-type: none"> • You can mount the device in a cabinet that contains a 19-in. rack as defined by the Electronics Industry Association. • The minimum cabinet size must be able to accommodate the maximum external dimensions of the device.
Cabinet clearance	<ul style="list-style-type: none"> • The outer edges of the mounting brackets extend the width of the chassis to 19 in. (48.2 cm). • The minimum total clearance inside the cabinet is 30 in. (76.2 cm) between the inside of the front door and the inside of the rear door.
Cabinet airflow requirements	<p>When you mount the device in a cabinet, ensure that ventilation through the cabinet is sufficient to prevent overheating.</p> <ul style="list-style-type: none"> • Ensure adequate cool air supply to dissipate the thermal output of the device or devices. • Ensure that the hot air exhaust of the chassis exits the cabinet without recirculating into the device. An open cabinet (without a top or doors) that employs hot air exhaust extraction from the top ensures the best airflow through the chassis. If the cabinet contains a top or doors, perforations in these elements assist with removing the hot air exhaust. • Install the device in the cabinet in a way that maximizes the open space on the side of the chassis that has the hot air exhaust. • Route and dress all cables to minimize the blockage of airflow to and from the chassis. • Ensure that the spacing of rails and adjacent cabinets is such that there is proper clearance around the device and cabinet. • A cabinet larger than the minimum required provides better airflow and reduces the chance of overheating.

Related Documentation • [Rack-Mounting and Cabinet-Mounting Warnings on page 224](#)

Clearance Requirements for Airflow and Hardware Maintenance for EX2300 Switches

When planning the site for installing an EX2300 switch, you must allow sufficient clearance around the installed switch. [Figure 24 on page 64](#) shows the clearance requirements for the EX2300-C switch models. [Figure 25 on page 65](#) shows the clearance requirements for EX2300 switches, except the EX2300-C switch model, with PoE capability. The depth of EX2300 switches, except the EX2300-C switch model, without PoE capability is 10 in. (25.4 cm).

Figure 24: Clearance Requirements for Airflow and Hardware Maintenance for EX2300-C Switches

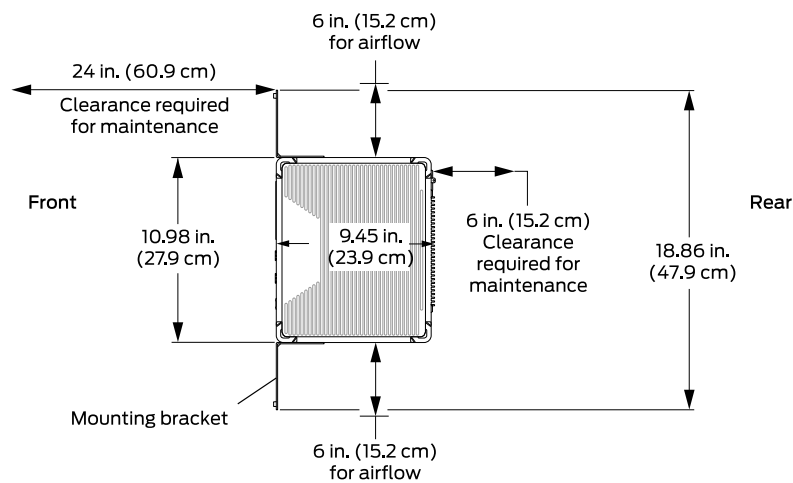

8022205

Figure 25: Clearance Requirements for Airflow and Hardware Maintenance for EX2300 Switches Except EX2200-C Switches

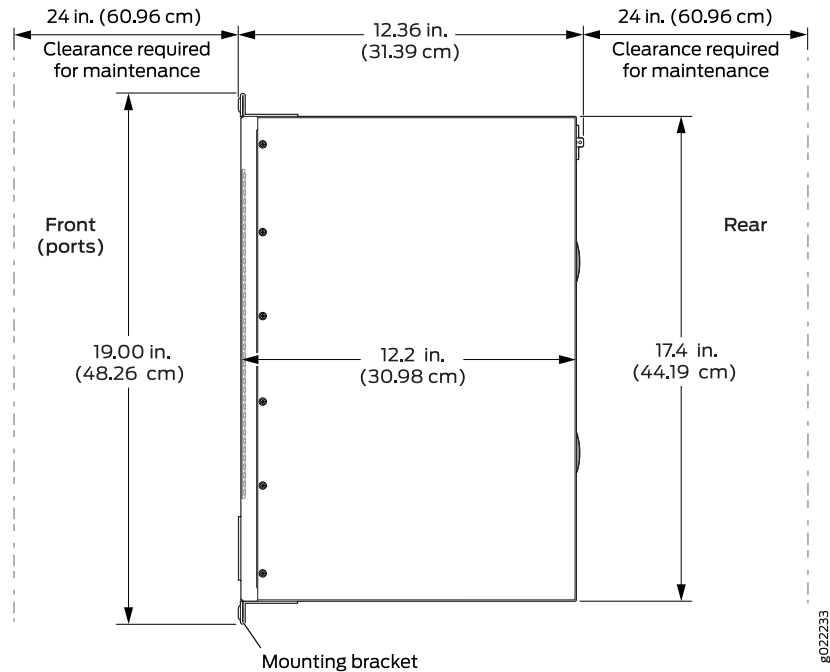

The power cord retainer clips in EX2300 switches except the EX2300-24MP model and the EX2300-48MP model extend out of the rear of the chassis by 3 in. (7.6 cm).

- Allow at least 6 in. (15.2 cm) of clearance on the side between devices that have fans installed. Allow 2.8 in. (7 cm) between the side of the chassis and any non-heat-producing surface such as a wall. For the cooling system to function properly, the airflow around the chassis must be unrestricted.

Figure 26 on page 66 shows the airflow in EX2300 switches with 24 ports with PoE capability. Figure 27 on page 66 shows the airflow in EX2300 switches with 48 ports with PoE capability. Figure 28 on page 67 shows the airflow in EX2300 switches without PoE capability.

Figure 26: Airflow Direction in EX2300 Switches with 24 Ports with PoE Capability

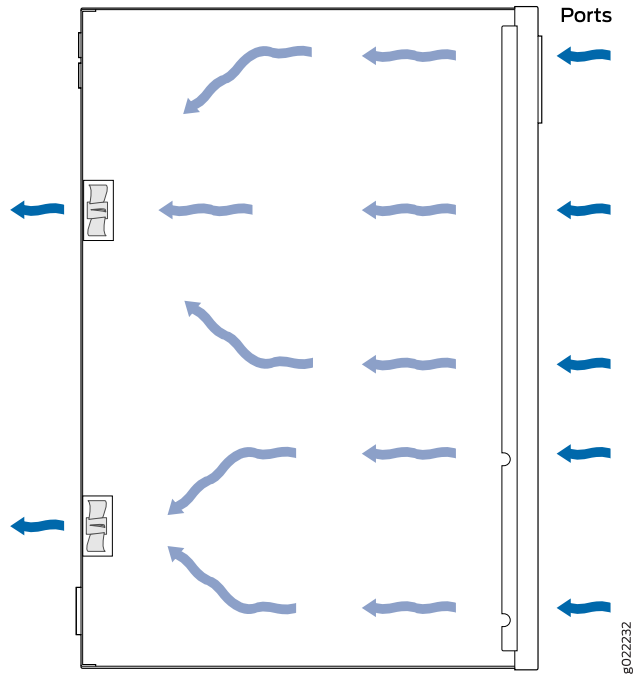

Figure 27: Airflow Direction in EX2300 Switches with 48 Ports with PoE Capability

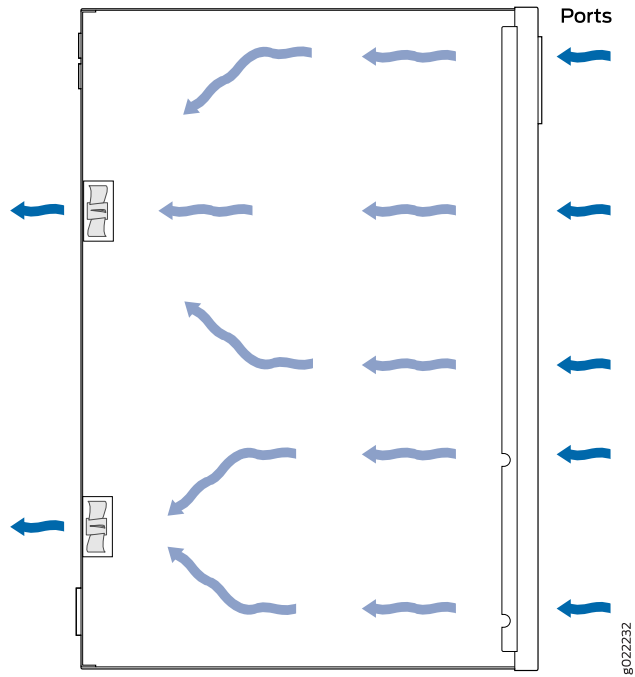
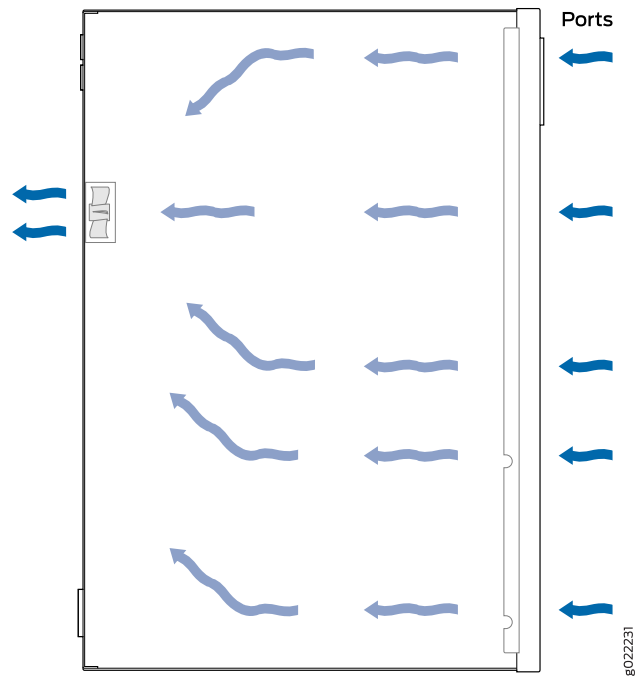

Figure 28: Airflow Direction in EX2300 Switches without PoE Capability



- If you are mounting an EX2300 switch in a rack or cabinet with other equipment, or if you are placing it on or under a desk or floor near other equipment, ensure that the exhaust from other equipment does not blow into the intake vents of the chassis.



NOTE: You can mount only EX2300-C switches under a desk or other level surface.

- Leave at least 24 in. (61 cm) in front of the switch and 6 in. (15.2 cm) behind the switch. For service personnel to remove and install hardware components, you must leave adequate space at the front and back of the switch. NEBS GR-63 recommends that you allow at least 30 in. (76.2 cm) in front of the rack or cabinet and 24 in. (61 cm) behind the rack or cabinet.

Related Documentation

- [Rack Requirements on page 61](#)
- [Cabinet Requirements on page 63](#)
- [General Site Guidelines on page 59](#)
- [Rack-Mounting and Cabinet-Mounting Warnings on page 224](#)
- [Cooling System and Airflow in an EX2300 Switch on page 25](#)

CHAPTER 7

Power Specifications and Requirements

- [Power Specifications for EX2300 Switches on page 69](#)
- [AC Power Cord Specifications for EX2300 Switches on page 70](#)
- [Calculating the EX Series Switch Fiber-Optic Cable Power Budget on page 72](#)
- [Calculating the EX Series Switch Fiber-Optic Cable Power Margin on page 72](#)

Power Specifications for EX2300 Switches

This topic describes the power supply electrical specifications for EX2300 switches.

[Table 36 on page 69](#) provides the AC power supply electrical specifications for EX2300 switches.

[Table 37 on page 70](#) provides the DC power supply electrical specifications for EX2300 switches.

Table 36: AC Power Supply Electrical Specifications for EX2300 Switches

Item	Specification
AC input supply	100 through 240 VAC
AC input line frequency	50 Hz/60 Hz nominal
AC system current rating	<ul style="list-style-type: none">• EX2300-C-12T: 1 A at 100 VAC• EX2300-C-12T: 0.5 A at 240 VAC• EX2300-C-12P: 2.5 A at 100 VAC• EX2300-C-12P: 1.25 A at 240 VAC• EX2300-24T: 2.5 A at 100 VAC• EX2300-24T: 1.25 A at 240 VAC• EX2300-24P: 7 A at 100 VAC• EX2300-24P: 3.5 A at 240 VAC• EX2300-24MP: 1.95 A at 240 VAC and 4.74 A at 100 VAC• EX2300-48T: 1.2 A at 100 VAC• EX2300-48T: 0.6 A at 240 VAC• EX2300-48P: 12 A at 100 VAC• EX2300-48P: 6 A at 240 VAC• EX2300-48MP: 3.83 A at 240 VAC and 9.57 A at 100 VAC

Table 37: DC Power Supply Electrical Specifications for EX2300 Switches (Except EX2300-C, EX2300-24MP, and EX2300-48MP Switches)

Item	Specification
DC input voltage	-48 through -60 VDC
DC input current	2.8 A maximum
Power supply output	100 W
Output holdup time	5 ms minimum



NOTE: For DC power supplies, we recommend that you provide at least 2.8 A at 48 VDC and use a facility circuit breaker rated for 10 A minimum. Doing so enables you to operate the switch in any configuration without upgrading the power infrastructure, and enables the switch to function at full capacity using multiple power supplies.

Related Documentation

- [AC Power Cord Specifications for EX2300 Switches on page 70](#)
- [Power Supply in EX2300 Switches on page 29](#)
- [General Safety Guidelines and Warnings on page 213](#)
- [General Electrical Safety Guidelines and Warnings on page 241](#)

AC Power Cord Specifications for EX2300 Switches

A detachable AC power cord is supplied with the AC power supplies. The coupler is type C13 as described by International Electrotechnical Commission (IEC) standard 60320. The plug at the male end of the power cord fits into the power source outlet that is standard for your geographical location.



CAUTION: The AC power cord provided with each power supply is intended for use with that power supply only and not for any other use.



NOTE: In North America, AC power cords must not exceed 4.5 meters in length, to comply with National Electrical Code (NEC) Sections 400-8 (NFPA 75, 5-2.2) and 210-52 and Canadian Electrical Code (CEC) Section 4-010(3). The cords supplied with the switch are in compliance.

[Table 38 on page 71](#) gives the AC power cord specifications for the countries and regions listed in the table.

Table 38: AC Power Cord Specifications

Country/Region	Electrical Specifications	Plug Standards	Juniper Model Number
Argentina	250 VAC, 10 A, 50 Hz	IRAM 2073 Type RA/3	CBL-EX-PWR-C13-AR
Australia	250 VAC, 10 A, 50 Hz	AS/NZS 3112 Type SAA/3	CBL-EX-PWR-C13-AU
Brazil	250 VAC, 10 A, 50 Hz	NBR 14136 Type BR/3	CBL-EX-PWR-C13-BR
China	250 VAC, 10 A, 50 Hz	GB 1002-1996 Type PRC/3	CBL-EX-PWR-C13-CH
Europe (except Italy, Switzerland, and United Kingdom)	250 VAC, 10 A, 50 Hz	CEE (7) VII Type VIIG	CBL-EX-PWR-C13-EU
India	250 VAC, 10 A, 50 Hz	IS 1293 Type IND/3	CBL-EX-PWR-C13-IN
Israel	250 VAC, 10 A, 50 Hz	SI 32/1971 Type IL/3G	CBL-EX-PWR-C13-IL
Italy	250 VAC, 10 A, 50 Hz	CEI 23-16 Type I/3G	CBL-EX-PWR-C13-IT
Japan	125 VAC, 12 A, 50 Hz or 60 Hz	SS-00259 Type VCTF	CBL-EX-PWR-C13-JP
Korea	250 VAC, 10 A, 50 Hz or 60 Hz	CEE (7) VII Type VIIGK	CBL-EX-PWR-C13-KR
North America	125 VAC, 13 A, 60 Hz	NEMA 5-15 Type N5-15	CBL-EX-PWR-C13-US
South Africa	250 VAC, 10 A, 50 Hz	SABS 164/1:1992 Type ZA/13	CBL-EX-PWR-C13-SA
Switzerland	250 VAC, 10 A, 50 Hz	SEV 6534-2 Type 12G	CBL-EX-PWR-C13-SZ
Taiwan	125 VAC, 11 A and 15 A, 50 Hz	NEMA 5-15P Type N5-15P	CBL-EX-PWR-C13-TW
United Kingdom	250 VAC, 10 A, 50 Hz	BS 1363/A Type BS89/13	CBL-EX-PWR-C13-UK

Figure 29 on page 71 illustrates the plug on the power cord for some of the countries or regions listed in Table 38 on page 71.

Figure 29: AC Plug Types

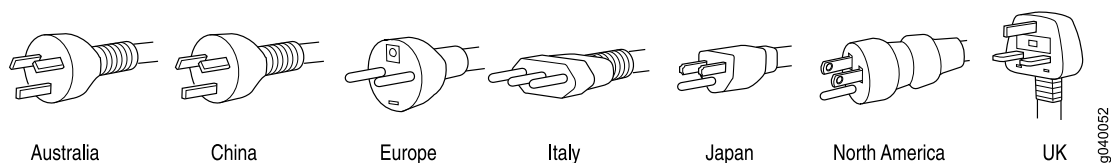

Related Documentation

- [Power Supply in EX2300 Switches on page 29](#)
- [General Safety Guidelines and Warnings on page 213](#)
- [General Electrical Safety Guidelines and Warnings on page 241](#)

- [Prevention of Electrostatic Discharge Damage on page 243](#)

Calculating the EX Series Switch Fiber-Optic Cable Power Budget

Calculate the link's power budget when planning fiber-optic cable layout and distances to ensure that fiber-optic connections have sufficient power for correct operation. The power budget is the maximum amount of power the link can transmit. When you calculate the power budget, you use a worst-case analysis to provide a margin of error, even though all the parts of an actual system do not operate at the worst-case levels.

To calculate the worst-case estimate for fiber-optic cable power budget (P_B) for the link:

1. Determine values for the link's minimum transmitter power (P_T) and minimum receiver sensitivity (P_R). For example, here, (P_T) and (P_R) are measured in decibels, and decibels are referred to one milliwatt (dBm).

$$P_T = -15 \text{ dBm}$$

$$P_R = -28 \text{ dBm}$$



NOTE: See the specifications for your transmitter and receiver to find the minimum transmitter power and minimum receiver sensitivity.

2. Calculate the power budget (P_B) by subtracting (P_R) from (P_T):

$$-15 \text{ dBm} - (-28 \text{ dBm}) = 13 \text{ dBm}$$

Related Documentation

- [Calculating the EX Series Switch Fiber-Optic Cable Power Margin on page 72](#)
- [Understanding EX Series Switches Fiber-Optic Cable Signal Loss, Attenuation, and Dispersion on page 83](#)
- [Pluggable Transceivers Supported on EX Series Switches on page 76](#)

Calculating the EX Series Switch Fiber-Optic Cable Power Margin

Calculate the link's power margin when planning fiber-optic cable layout and distances to ensure that fiber-optic connections have sufficient signal power to overcome system losses and still satisfy the minimum input requirements of the receiver for the required performance level. The power margin (P_M) is the amount of power available after attenuation or link loss (LL) has been subtracted from the power budget (P_B).

When you calculate the power margin, you use a worst-case analysis to provide a margin of error, even though all the parts of an actual system do not operate at worst-case levels. A power margin (P_M) greater than zero indicates that the power budget is sufficient to operate the receiver and that it does not exceed the maximum receiver input power.

This means the link will work. A (P_M) that is zero or negative indicates insufficient power to operate the receiver. See the specification for your receiver to find the maximum receiver input power.

Before you begin to calculate the power margin:

- Calculate the power budget. See “Calculating the EX Series Switch Fiber-Optic Cable Power Budget” on page 72.

To calculate the worst-case estimate for the power margin (P_M) for the link:

1. Determine the maximum value for link loss (LL) by adding estimated values for applicable link-loss factors—for example, use the sample values for various factors as provided in Table 39 on page 73 (here, the link is 2 km long and multimode, and the (P_B) is 13 dBm):

Table 39: Estimated Values for Factors Causing Link Loss

Link-Loss Factor	Estimated Link-Loss Value	Sample (LL) Calculation Values
Higher-order mode losses (HOL)	<ul style="list-style-type: none"> • Multimode—0.5 dBm • Single mode—None 	<ul style="list-style-type: none"> • 0.5 dBm • 0 dBm
Modal and chromatic dispersion	<ul style="list-style-type: none"> • Multimode—None, if product of bandwidth and distance is less than 500 MHz/km • Single mode—None 	<ul style="list-style-type: none"> • 0 dBm • 0 dBm
Connector	0.5 dBm	<p>This example assumes 5 connectors. Loss for 5 connectors:</p> <p>(5) * (0.5 dBm) = 2.5 dBm</p>
Splice	0.5 dBm	<p>This example assumes 2 splices. Loss for two splices:</p> <p>(2) * (0.5 dBm) = 1 dBm</p>
Fiber attenuation	<ul style="list-style-type: none"> • Multimode—1 dBm/km • Single mode—0.5 dBm/km 	<p>This example assumes the link is 2 km long. Fiber attenuation for 2 km:</p> <ul style="list-style-type: none"> • (2 km) * (1.0 dBm/km) = 2 dBm • (2 km) * (0.5 dBm/km) = 1 dBm
Clock Recovery Module (CRM)	1 dBm	1 dBm



NOTE: For information about the actual amount of signal loss caused by equipment and other factors, see your vendor documentation for that equipment.

2. Calculate the (P_M) by subtracting (LL) from (P_B):

$$P_B - LL = P_M$$

$$(13 \text{ dBm}) - (0.5 \text{ dBm [HOL]}) - ((5) * (0.5 \text{ dBm})) - ((2) * (0.5 \text{ dBm})) - ((2 \text{ km}) * (1.0 \text{ dBm/km})) - (1 \text{ dB [CRM]}) = P_M$$

$$13 \text{ dBm} - 0.5 \text{ dBm} - 2.5 \text{ dBm} - 1 \text{ dBm} - 2 \text{ dBm} - 1 \text{ dBm} = P_M$$

$$P_M = 6 \text{ dBm}$$

The calculated power margin is greater than zero, indicating that the link has sufficient power for transmission. Also, the power margin value does not exceed the maximum receiver input power. Refer to the specification for your receiver to find the maximum receiver input power.

Related Documentation

- [Calculating the EX Series Switch Fiber-Optic Cable Power Budget on page 72](#)
- [Understanding EX Series Switches Fiber-Optic Cable Signal Loss, Attenuation, and Dispersion on page 83](#)
- [Pluggable Transceivers Supported on EX Series Switches on page 76](#)

Transceiver and Cable Specifications

- [Pluggable Transceivers Supported on EX2300 Switches on page 75](#)
- [Pluggable Transceivers Supported on EX Series Switches on page 76](#)
- [SFP+ Direct Attach Copper Cables for EX Series Switches on page 80](#)
- [Management Cable Specifications on page 82](#)
- [Understanding EX Series Switches Fiber-Optic Cable Signal Loss, Attenuation, and Dispersion on page 83](#)

Pluggable Transceivers Supported on EX2300 Switches

Uplink ports on the front panel in EX2300 switches support SFP and SFP+ transceivers. You can find the list of transceivers supported on EX2300 switches and information about those transceivers at the [Hardware Compatibility Tool page for EX2300](#).



NOTE: We recommend that you use only optical transceivers and optical connectors purchased from Juniper Networks with your Juniper Networks device.



CAUTION: If you face a problem running a Juniper Networks device that uses a third-party optic or cable, the Juniper Networks Technical Assistance Center (JTAC) can help you diagnose the source of the problem. Your JTAC engineer might recommend that you check the third-party optic or cable and potentially replace it with an equivalent Juniper Networks optic or cable that is qualified for the device.



NOTE: EX2300-C switches ensure normal operation in the temperature range 32° F (0° C) through 104° F (40° C) at altitudes up to 5,000 ft (1,524 m). In the temperature range 104° F (40° C) through 113° F (45° C) at altitudes up to 5,000 ft (1,524 m), use extended temperature range SFP transceivers.

The Gigabit Ethernet SFP and SFP+ transceivers installed in EX2300 switches support digital optical monitoring (DOM): You can view the diagnostic details for these transceivers by issuing the operational mode CLI command **show interfaces diagnostics optics**.



NOTE: The transceivers support DOM even if they are installed in uplink ports configured as Virtual Chassis ports.

**Related
Documentation**

- [EX2300 Switches Hardware Overview on page 3](#)
- [Installing a Transceiver on page 175](#)
- [Removing a Transceiver on page 177](#)

Pluggable Transceivers Supported on EX Series Switches

The transceivers for EX Series switches are hot-removable and hot-insertable field-replaceable units (FRUs): You can remove and replace them without powering off the switch or disrupting switch functions.



NOTE: After you insert a transceiver or after you change the media-type configuration, wait for 6 seconds for the interface to display the operational commands.



NOTE: We recommend that you use only optical transceivers and optical connectors purchased from Juniper Networks with your Juniper Networks device.



CAUTION: If you face a problem running a Juniper Networks device that uses a third-party optic or cable, the Juniper Networks Technical Assistance Center (JTAC) can help you diagnose the source of the problem. Your JTAC engineer might recommend that you check the third-party optic or cable and potentially replace it with an equivalent Juniper Networks optic or cable that is qualified for the device.

- EX2200—Uplink ports and dual-purpose uplink ports on the front panel in EX2200 switches support SFP transceivers. You can find the list of transceivers supported on EX2200 switches and information about those transceivers at the [Hardware Compatibility Tool page for EX2200](#).



NOTE: EX2200-C switches ensure normal operation in the temperature range 30° F (0° C) through 104° F (40° C) at altitudes up to 5,000 ft (1,524 m).

In the following conditions, use extended temperature range SFP transceivers when fiber uplinks are used:

- In the temperature range 104° F (40° C) through 113° F (45° C) at altitudes up to 5,000 ft (1,524 m)
 - In the temperature range 95° F (35° C) through 113° F (45° C) at altitudes above 5,000 ft (1,524 m) up to 10,000 ft (3,048 m)
- EX2300—Uplink ports on the front panel in EX2300 switches support SFP and SFP+ transceivers. You can find the list of transceivers supported on EX2300 switches and information about those transceivers at the [Hardware Compatibility Tool page for EX2300](#).



NOTE: EX2300-C switches ensure normal operation in the temperature range 32° F (0° C) through 104° F (40° C) at altitudes up to 5,000 ft (1,524 m).

In the temperature range 104° F (40° C) through 113° F (45° C) at altitudes up to 5,000 ft (1,524 m), use extended temperature range SFP transceivers.

The Gigabit Ethernet SFP and SFP+ transceivers installed in EX2300 switches support digital optical monitoring (DOM): You can view the diagnostic details for these transceivers by issuing the operational mode CLI command **show interfaces diagnostics optics**.



NOTE: The transceivers support DOM even if they are installed in uplink ports configured as Virtual Chassis ports.

- EX3200—Optional uplink modules for EX3200 switches support SFP, SFP+, or XFP transceivers. You can find the list of transceivers supported on EX3200 switches and information about those transceivers at the [Hardware Compatibility Tool page for EX3200](#).

The Gigabit Ethernet SFP, SFP+, or XFP transceivers installed in EX3200 switches support digital optical monitoring (DOM): You can view the diagnostic details for these transceivers by issuing the operational mode CLI command **show interfaces diagnostics optics**.

- EX3300—Uplink ports on the front panel in EX3300 switches support SFP and SFP+ transceivers. You can find the list of transceivers supported on EX3300 switches and

information about those transceivers at the [Hardware Compatibility Tool page for EX3300](#).

The Gigabit Ethernet SFP and SFP+ transceivers installed in EX3300 switches support digital optical monitoring (DOM): you can view the diagnostic details for these transceivers by issuing the operational mode CLI command **show interfaces diagnostics optics**.



NOTE: The transceivers support DOM even if they are installed in uplink ports configured as Virtual Chassis ports.

- EX3400—Uplink ports on EX3400 switches support SFP, SFP+, and QSFP+ transceivers. You can find the list of transceivers supported on EX3400 switches and information about those transceivers at the [Hardware Compatibility Tool page for EX3400](#).

The Gigabit Ethernet SFP, SFP+, and QSFP+ transceivers installed in EX3400 switches support digital optical monitoring (DOM): You can view the diagnostic details for these transceivers by issuing the operational mode CLI command **show interfaces diagnostics optics**.



NOTE: The transceivers support DOM even if they are installed in uplink ports configured as Virtual Chassis ports.

- EX4200—Optional uplink modules for EX4200 switches support SFP, SFP+, or XFP transceivers. You can find the list of transceivers supported on EX4200 switches and information about those transceivers at the [Hardware Compatibility Tool page for EX4200](#).

The Gigabit Ethernet SFP, SFP+, or XFP transceivers installed in EX4200 switches support digital optical monitoring (DOM): You can view the diagnostic details for these transceivers by issuing the operational mode CLI command **show interfaces diagnostics optics**.



NOTE: The transceivers support DOM even if they are installed in uplink module ports configured as Virtual Chassis ports.

- EX4300—Optional uplink modules for EX4300 switches support SFP, SFP+, and QSFP+ transceivers. You can find the list of transceivers supported on EX4300 switches and information about those transceivers at the [Hardware Compatibility Tool page for EX4300](#).

The Gigabit Ethernet SFP, SFP+, and QSFP+ transceivers installed in EX4300 switches support digital optical monitoring (DOM): You can view the diagnostic details for these transceivers by issuing the operational mode CLI command **show interfaces diagnostics optics**.



NOTE: The transceivers support DOM even if they are installed in the SFP+ uplink module ports or QSFP+ ports configured as Virtual Chassis ports (VCPs).

- EX4500—Uplink module ports on EX4500 switches support SFP and SFP+ transceivers. You can find the list of transceivers supported on EX4500 switches and information about those transceivers at the [Hardware Compatibility Tool page for EX4500](#).

The Gigabit Ethernet SFP and SFP+ transceivers installed in EX4500 switches support digital optical monitoring (DOM): You can view the diagnostic details for these transceivers by issuing the operational mode CLI command **show interfaces diagnostics optics**.



NOTE: The transceivers support DOM even if they are installed in uplink module ports configured as Virtual Chassis ports.

- EX4550—Uplink module ports on EX4550 switches support SFP, SFP+, and QSFP+ transceivers. You can find the list of transceivers supported on EX4550 switches and information about those transceivers at the [Hardware Compatibility Tool page for EX4550](#).

The SFP, SFP+, and QSFP+ transceivers installed in EX4550 switches support digital optical monitoring (DOM): You can view the diagnostic details for these transceivers by issuing the operational mode CLI command **show interfaces diagnostics optics**.



NOTE: The transceivers support DOM even if they are installed in the expansion module ports or SFP+ network ports configured as Virtual Chassis ports (VCPs).

- EX4600—The quad small form-factor pluggable plus (QSFP+) ports in EX4600 switches support QSFP+ transceivers, QSFP+ direct-attach copper (DAC) cables, and DAC breakout cables (DACBO). Each QSFP+ port on an EX4600 switch can be configured to operate as 10-Gigabit Ethernet interface by using a breakout cable or as a single 40-Gigabit Ethernet interface. The ports on an EX4600 switch are disabled by default. You enable a port through the CLI. The 24 downlink or access ports of the EX4600 switch are 10-Gigabit Ethernet. You can find the list of transceivers supported on EX4600 switches and information about those transceivers at the [Hardware Compatibility Tool page for EX4600](#).
- EX6200—Uplink ports on the Switch Fabric and Routing Engine (SRE) module and line cards in EX6200 switches support SFP and SFP+ transceivers. You can find the list of transceivers supported on EX6200 switches and information about those transceivers at the [Hardware Compatibility Tool page for EX6200](#).

The Gigabit Ethernet SFP and SFP+ transceivers installed in EX6200 switches support digital optical monitoring (DOM). You can view the diagnostic details for these

transceivers by issuing the operational mode CLI command **show interfaces diagnostics optics**.

- EX8200—The line cards on EX8200 switches support SFP and SFP+ transceivers.
 - You can find the list of transceivers supported on EX8208 switches and information about those transceivers at the [Hardware Compatibility Tool page for EX8208](#).
 - You can find the list of transceivers supported on EX8216 switches and information about those transceivers at the [Hardware Compatibility Tool page for EX8216](#).

The Gigabit Ethernet SFP and SFP+ transceivers installed in EX8200 switches support digital optical monitoring (DOM): You can view the diagnostic details for these transceivers by issuing the operational mode CLI command **show interfaces diagnostics optics**.

- EX9200—The line cards in EX9200 switches support 1-gigabit Ethernet small form-factor pluggable (SFP), 1-gigabit Fast Ethernet SFP, 10-gigabit small form-factor pluggable plus (SFP+), 40-gigabit quad small form-factor pluggable plus (QSFP+), and 100-gigabit C form-factor pluggable (CFP) transceivers.
 - You can find the list of transceivers supported on EX9204 switches and information about those transceivers at the [Hardware Compatibility Tool page for EX9204](#).
 - You can find the list of transceivers supported on EX9208 switches and information about those transceivers at the [Hardware Compatibility Tool page for EX9208](#).
 - You can find the list of transceivers supported on EX9214 switches and information about those transceivers at the [Hardware Compatibility Tool page for EX9214](#).

The Gigabit Ethernet SFP, SFP+, and QSFP+ transceivers and the 100GBASE-LR4 CFP transceivers installed in EX9200 switches support digital optical monitoring (DOM): You can view the diagnostic details for these transceivers by issuing the operational mode CLI command **show interfaces diagnostics optics**.

Related Documentation

- [Installing a Transceiver on page 175](#)
- [Removing a Transceiver on page 177](#)
- [Connecting a Fiber-Optic Cable on page 151](#)

SFP+ Direct Attach Copper Cables for EX Series Switches

Small form-factor pluggable plus transceiver (SFP+) direct attach copper (DAC) cables, also known as Twinax cables, are suitable for in-rack connections between servers and switches. They are suitable for short distances, making them ideal for highly cost-effective networking connectivity within a rack and between adjacent racks.



NOTE: We recommend that you use only SFP+ DAC cables purchased from Juniper Networks with your Juniper Networks device.



CAUTION: If you face a problem running a Juniper Networks device that uses a third-party optic or cable, the Juniper Networks Technical Assistance Center (JTAC) can help you diagnose the source of the problem. Your JTAC engineer might recommend that you check the third-party optic or cable and potentially replace it with an equivalent Juniper Networks optic or cable that is qualified for the device.

This topic describes:

- [Cable Specifications on page 81](#)
- [List of DAC Cables Supported on EX Series Switches on page 81](#)
- [Standards Supported by These Cables on page 82](#)

Cable Specifications

EX Series switches support SFP+ passive DAC cables. The passive Twinax cable is a straight cable with no active electronic components. EX Series switches support 1 m, 3 m, 5 m, and 7 m long SFP+ passive DAC cables. See [Figure 30 on page 81](#).

Figure 30: SFP+ Direct Attach Copper Cables for EX Series Switches

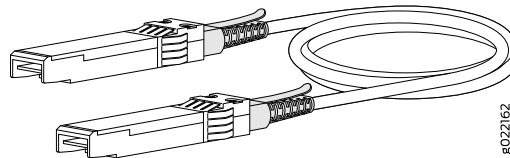

The cables are hot-removable and hot-insertable: You can remove and replace them without powering off the switch or disrupting switch functions. A cable comprises a low-voltage cable assembly that connects directly into two 10-Gigabit Ethernet ports, one at each end of the cable. The cables use high-performance integrated duplex serial data links for bidirectional communication and are designed for data rates of up to 10 Gbps.

List of DAC Cables Supported on EX Series Switches

For the list of DAC cables supported on EX Series switches and the specifications of these cables, see:

- EX2300—[Hardware Compatibility Tool page for EX2300](#)
- EX3200—[Hardware Compatibility Tool page for EX3200](#)
- EX3300—[Hardware Compatibility Tool page for EX3300](#)
- EX3400—[Hardware Compatibility Tool page for EX3400](#)
- EX4200—[Hardware Compatibility Tool page for EX4200](#)
- EX4300—[Hardware Compatibility Tool page for EX4300](#)
- EX4500—[Hardware Compatibility Tool page for EX4500](#)

- EX4550—[Hardware Compatibility Tool page for EX4550](#)
- EX4600—[Hardware Compatibility Tool page for EX4600](#)
- EX8208—[Hardware Compatibility Tool page for EX8208](#)
- EX8216—[Hardware Compatibility Tool page for EX8216](#)

Standards Supported by These Cables

The cables comply with the following standards:

- SFP mechanical standard SFF-843—see <ftp://ftp.seagate.com/sff/SFF-8431.PDF>.
- Electrical interface standard SFF-8432—see <ftp://ftp.seagate.com/sff/SFF-8432.PDF>.
- SFP+ Multi-Source Alliance (MSA) standards

Related Documentation

- [Pluggable Transceivers Supported on EX Series Switches on page 76](#)
- [Installing a Transceiver on page 175](#)
- [Removing a Transceiver on page 177](#)

Management Cable Specifications

Table 40 on page 82 lists the specifications for the cables that connect the console (CON) and management (MGMT) ports to management devices.

Table 40: Specifications of Cables to Connect to Management Devices

Ports	Cable Specifications	Receptacle	Additional Information
RJ-45 Console (CON2) port	CAT5e UTP (unshielded twisted pair) cable	RJ-45	"Connecting a Device to a Management Console by Using an RJ-45 Connector" on page 148
Management (MGMT) Ethernet port (10/100/1000)	—	—	"Connecting a Device to a Network for Out-of-Band Management" on page 147
Mini-USB Type-B Console (CON1) port	—	—	

Understanding EX Series Switches Fiber-Optic Cable Signal Loss, Attenuation, and Dispersion

To determine the power budget and power margin needed for fiber-optic connections, you need to understand how signal loss, attenuation, and dispersion affect transmission. EX Series Switches use various types of network cable, including multimode and single-mode fiber-optic cable.

- [Signal Loss in Multimode and Single-Mode Fiber-Optic Cable on page 83](#)
- [Attenuation and Dispersion in Fiber-Optic Cable on page 83](#)

Signal Loss in Multimode and Single-Mode Fiber-Optic Cable

Multimode fiber is large enough in diameter to allow rays of light to reflect internally (bounce off the walls of the fiber). Interfaces with multimode optics typically use LEDs as light sources. However, LEDs are not coherent light sources. They spray varying wavelengths of light into the multimode fiber, which reflects the light at different angles. Light rays travel in jagged lines through a multimode fiber, causing signal dispersion. When light traveling in the fiber core radiates into the fiber cladding (layers of lower refractive index material in close contact with a core material of higher refractive index), higher-order mode loss (HOL) occurs. Together, these factors reduce the transmission distance of multimode fiber compared to that of single-mode fiber.

Single-mode fiber is so small in diameter that rays of light reflect internally through one layer only. Interfaces with single-mode optics use lasers as light sources. Lasers generate a single wavelength of light, which travels in a straight line through the single-mode fiber. Compared to multimode fiber, single-mode fiber has a higher bandwidth and can carry signals for longer distances. It is consequently more expensive.

Exceeding the maximum transmission distances can result in significant signal loss, which causes unreliable transmission. For information about the maximum transmission distance and supported wavelength range for the types of single-mode and multimode fiber-optic cables that are used on different EX Series switches see [“Pluggable Transceivers Supported on EX Series Switches” on page 76](#).

Attenuation and Dispersion in Fiber-Optic Cable

An optical data link functions correctly provided that modulated light reaching the receiver has enough power to be demodulated correctly. *Attenuation* is the reduction in strength of the light signal during transmission. Passive media components such as cables, cable splices, and connectors cause attenuation. Although attenuation is significantly lower for optical fiber than for other media, it still occurs in both multimode and single-mode transmission. An efficient optical data link must transmit enough light to overcome attenuation.

Dispersion is the spreading of the signal over time. The following two types of dispersion can affect signal transmission through an optical data link:

- Chromatic dispersion, which is the spreading of the signal over time caused by the different speeds of light rays.

- Modal dispersion, which is the spreading of the signal over time caused by the different propagation modes in the fiber.

For multimode transmission, modal dispersion, rather than chromatic dispersion or attenuation, usually limits the maximum bit rate and link length. For single-mode transmission, modal dispersion is not a factor. However, at higher bit rates and over longer distances, chromatic dispersion limits the maximum link length.

An efficient optical data link must have enough light to exceed the minimum power that the receiver requires to operate within its specifications. In addition, the total dispersion must be within the limits specified for the type of link in Telcordia Technologies document GR-253-CORE (Section 4.3) and International Telecommunications Union (ITU) document G.957.

When chromatic dispersion is at the maximum allowed, its effect can be considered as a power penalty in the power budget. The optical power budget must allow for the sum of component attenuation, power penalties (including those from dispersion), and a safety margin for unexpected losses.

**Related
Documentation**

- [Calculating the EX Series Switch Fiber-Optic Cable Power Budget on page 72](#)
- [Calculating the EX Series Switch Fiber-Optic Cable Power Margin on page 72](#)

CHAPTER 9

Pinout Specifications

- [Console Port Connector Pinout Information on page 85](#)
- [USB Port Specifications for an EX Series Switch on page 86](#)
- [Mini-USB Port Pinout Specifications on page 87](#)
- [RJ-45 Management Port Connector Pinout Information on page 88](#)
- [RJ-45 Port, QSFP+ Port, SFP+ Port, and SFP Port Connector Pinout Information on page 88](#)
- [SFP+ Uplink Port Connector Pinout Information for an EX2300 Switch on page 93](#)
- [RJ-45 to DB-9 Serial Port Adapter Pinout Information on page 94](#)

Console Port Connector Pinout Information

The console port on a Juniper Networks device is an RS-232 serial interface that uses an RJ-45 connector to connect to a console management device. The default baud rate for the console port is 9600 baud.

[Table 41 on page 85](#) provides the pinout information for the RJ-45 console connector.



NOTE: If your laptop or PC does not have a DB-9 male connector pin and you want to connect your laptop or PC directly to a device, use a combination of the RJ-45 to DB-9 female adapter and a USB to DB-9 male adapter. You must provide the USB to DB-9 male adapter.

Table 41: Console Port Connector Pinout Information

Pin	Signal	Description
1	RTS Output	Request to send
2	DTR Output	Data terminal ready
3	TxD Output	Transmit data
4	Signal Ground	Signal ground
5	Signal Ground	Signal ground

Table 41: Console Port Connector Pinout Information (*continued*)

Pin	Signal	Description
6	RxD Input	Receive data
7	CD Input	Data carrier detect
8	CTS Input	Clear to send

- Related Documentation**
- [Connecting a Device to a Management Console by Using an RJ-45 Connector on page 148](#)
 - [Configuring the Console Port Type \(CLI Procedure\)](#)

USB Port Specifications for an EX Series Switch

The following Juniper Networks USB flash drives have been tested and are officially supported for the USB port on all EX Series switches:

- RE-USB-1G-S
- RE-USB-2G-S
- RE-USB-4G-S



CAUTION: Any USB memory product not listed as supported for EX Series switches has not been tested by Juniper Networks. The use of any unsupported USB memory product could expose your EX Series switch to unpredictable behavior. Juniper Networks Technical Assistance Center (JTAC) can provide only limited support for issues related to unsupported hardware. We strongly recommend that you use only supported USB flash drives.

All USB flash drives used on EX Series switches must have the following features:

- USB 2.0 or later.
- Formatted with a FAT or MS-DOS file system.
- If the switch is running Junos OS Release 9.5 or earlier, the formatting method must use a master boot record. Microsoft Windows formatting, by default, does not use a master boot record. See the documentation for your USB flash drive for information about how your USB flash drive is formatted.

- Related Documentation**
- [EX2200 Switches Hardware Overview](#)
 - [EX2300 Switches Hardware Overview on page 3](#)
 - [Rear Panel of an EX3200 Switch](#)
 - [Rear Panel of an EX3300 Switch](#)

- *Rear Panel of an EX3400 Switch*
- *Rear Panel of an EX4200 Switch*
- *EX4300 Switches Hardware Overview*
- *Front Panel of an EX4500 Switch*
- *Management Panel of an EX4600 Switch*
- *EX4550 Switches Hardware Overview*
- *Switch Fabric and Routing Engine (SRE) Module in an EX6200 Switch*
- *Switch Fabric and Routing Engine (SRE) Module in an EX8208 Switch*
- *Routing Engine (RE) Module in an EX8216 Switch*
- *Routing Engine Module in an EX9200 Switch*
- *Booting an EX Series Switch Using a Software Package Stored on a USB Flash Drive*

Mini-USB Port Pinout Specifications

If your management host (laptop or PC) does not have a DB-9 male connector pin or an RJ-45 connector pin but has a USB port, you can connect your management host to the Mini-USB Type-B console port by using a cable that has a standard Type-A USB connector on one end and a Mini-USB Type-B (5-pin) connector on the other end.

The Mini-USB Type-B console port uses a Mini-USB Type-B connector to connect to a console management device. The default baud rate for the console port is 9600 baud.

[Table 42 on page 87](#) provides the pinout information of the Mini-USB Type-B console port.

Table 42: Mini-USB Type-B Console Port Pinout Information

Pin	Signal	Description
1	VCC	+5 VDC
2	D-	Data -
3	D+	Data +
X	N/C	Could be not connected (N/C), connected to ground (GND), or used as an attached device presence indicator
4	GND	Ground

Related Documentation • [Management Cable Specifications on page 82](#)

RJ-45 Management Port Connector Pinout Information

Table 43 on page 88 provides the pinout information for the RJ-45 connector for the management port on Juniper Networks devices.

Table 43: RJ-45 Management Port Connector Pinout Information

Pin	Signal	Description
1	TRP1+	Transmit/receive data pair 1
2	TRP1-	Transmit/receive data pair 1
3	TRP2+	Transmit/receive data pair 2
4	TRP3+	Transmit/receive data pair 3
5	TRP3-	Transmit/receive data pair 3
6	TRP2-	Transmit/receive data pair 2
7	TRP4+	Transmit/receive data pair 4
8	TRP4-	Transmit/receive data pair 4

Related Documentation

- [Connecting a Device to a Network for Out-of-Band Management on page 147](#)

RJ-45 Port, QSFP+ Port, SFP+ Port, and SFP Port Connector Pinout Information

Tables in this topic describe the connector pinout information for the RJ-45, QSFP+, SFP+, and SFP ports.

- [Table 44 on page 88](#)—10/100/1000BASE-T Ethernet network port connector pinout information
- [Table 45 on page 89](#)—SFP network port connector pinout information
- [Table 46 on page 90](#)—SFP+ network port connector pinout information
- [Table 47 on page 91](#)—QSFP+ network module port connector pinout information

Table 44: 10/100/1000BASE-T Ethernet Network Port Connector Pinout Information

Pin	Signal	Description
1	TRP1+	Transmit/receive data pair 1 Negative Vport (in PoE models)

Table 44: 10/100/1000BASE-T Ethernet Network Port Connector Pinout Information (*continued*)

Pin	Signal	Description
2	TRP1-	Transmit/receive data pair 1 Negative Vport (in PoE models)
3	TRP2+	Transmit/receive data pair 2 Positive Vport (in PoE models)
4	TRP3+	Transmit/receive data pair 3
5	TRP3-	Transmit/receive data pair 3
6	TRP2-	Transmit/receive data pair 2 Positive Vport (in PoE models)
7	TRP4+	Transmit/receive data pair 4
8	TRP4-	Transmit/receive data pair 4

Table 45: SFP Network Port Connector Pinout Information

Pin	Signal	Description
1	VeeT	Module transmitter ground
2	TX_Fault	Module transmitter fault
3	TX_Disable	Transmitter disabled
4	SDA	2-wire serial interface data line
5	SCL-	2-wire serial interface clock
6	MOD_ABS	Module absent
7	RS	Rate select
8	RX_LOS	Receiver loss of signal indication
9	VeeR	Module receiver ground
10	VeeR	Module receiver ground
11	VeeR	Module receiver ground
12	RD-	Receiver inverted data output

Table 45: SFP Network Port Connector Pinout Information (continued)

Pin	Signal	Description
13	RD+	Receiver noninverted data output
14	VeeR	Module receiver ground
15	VccR	Module receiver 3.3 V supply
16	VccT	Module transmitter 3.3 V supply
17	VeeT	Module transmitter ground
18	TD+	Transmitter noninverted data input
19	TD-	Transmitter inverted data input
20	VeeT	Module transmitter ground

Table 46: SFP+ Network Port Connector Pinout Information

Pin	Signal	Description
1	VeeT	Module transmitter ground
2	TX_Fault	Module transmitter fault
3	TX_Disable	Transmitter disabled
4	SDA	2-wire serial interface data line
5	SCL-	2-wire serial interface clock
6	MOD_ABS	Module absent
7	RS0	Rate select 0, optionally controls SFP+ module receiver
8	RX_LOS	Receiver loss of signal indication
9	RS1	Rate select 1, optionally controls SFP+ transmitter
10	VeeR	Module receiver ground
11	VeeR	Module receiver ground
12	RD-	Receiver inverted data output
13	RD+	Receiver noninverted data output
14	VeeR	Module receiver ground

Table 46: SFP+ Network Port Connector Pinout Information (*continued*)

Pin	Signal	Description
15	VccR	Module receiver 3.3 V supply
16	VccT	Module transmitter 3.3 V supply
17	VeeT	Module transmitter ground
18	TD+	Transmitter noninverted data input
19	TD-	Transmitter inverted data input
20	VeeT	Module transmitter ground

Table 47: QSFP+ Network Port Connector Pinout Information

Pin	Signal
1	GND
2	TX2n
3	TX2p
4	GND
5	TX4n
6	TX4p
7	GND
8	ModSelL
9	LPMODE_Reset
10	VccRx
11	SCL
12	SDA
13	GND
14	RX3p
15	RX3n
16	GND

Table 47: QSFP+ Network Port Connector Pinout Information (*continued*)

Pin	Signal
17	RX1p
18	RX1n
19	GND
20	GND
21	RX2n
22	RX2p
23	GND
24	RX4n
25	RX4p
26	GND
27	ModPrsL
28	IntL
29	VccTx
30	Vcc1
31	Reserved
32	GND
33	TX3p
34	TX3n
35	GND
36	TX1p
37	TX1n
38	GND

Related Documentation • [Installing a Transceiver on page 175](#)

SFP+ Uplink Port Connector Pinout Information for an EX2300 Switch

EX2300-C switches have two 10-Gigabit Ethernet uplink ports that support 1-gigabit SFP transceivers and 10-gigabit SFP+ transceivers. EX2300 switches except the EX2300-C switch model have four 10-Gigabit Ethernet uplink ports that support SFP and SFP+ transceivers.

Table 48 on page 93 provides the pinout information for the SFP+ uplink port connector.

Table 48: Connector Pinout Information for the 10-Gigabit Ethernet Uplink Port

Pin	Signal	Description
1	VeeT	Module transmitter ground
2	TX_Fault	Module transmitter fault
3	TX_Disable	Transmitter disabled
4	SDA	2-wire serial interface data line
5	SCL-	2-wire serial interface clock
6	MOD_ABS	Module absent
7	RS0	Rate select 0, optionally controls SFP+ module receiver
8	RX_LOS	Receiver loss of signal indication
9	RS1	Rate select 1, optionally controls SFP+ transmitter
10	VeeR	Module receiver ground
11	VeeR	Module receiver ground
12	RD-	Receiver inverted data output
13	RD+	Receiver noninverted data output
14	VeeR	Module receiver ground
15	VccR	Module receiver 3.3 V supply
16	VccT	Module transmitter 3.3 V supply
17	VeeT	Module transmitter ground
18	TD+	Transmitter noninverted data input
19	TD-	Transmitter inverted data input

Table 48: Connector Pinout Information for the 10-Gigabit Ethernet Uplink Port (*continued*)

Pin	Signal	Description
20	VeeT	Module transmitter ground

- Related Documentation**
- See [EX2300 Switches Hardware Overview](#) on page 3 for port location

RJ-45 to DB-9 Serial Port Adapter Pinout Information

The console port is an RS-232 serial interface that uses an RJ-45 connector to connect to a management device such as a PC or a laptop. If your laptop or PC does not have a DB-9 male connector pin and you want to connect your laptop or PC to the device, use a combination of the RJ-45 to DB-9 female adapter along with a USB to DB-9 male adapter.

[Table 49 on page 94](#) provides the pinout information for the RJ-45 to DB-9 serial port adapter.

Table 49: RJ-45 to DB-9 Serial Port Adapter Pinout Information

RJ-45 Pin	Signal	DB-9 Pin	Signal
1	RTS	8	CTS
2	DTR	6	DSR
3	TXD	2	RXD
4	GND	5	GND
6	RXD	3	TXD
7	DSR	4	DTR
8	CTS	7	RTS

- Related Documentation**
- [Connecting a Device to a Management Console by Using an RJ-45 Connector](#) on page 148

Planning the Virtual Chassis

- [Planning EX2300 Virtual Chassis on page 95](#)
- [Understanding EX2300 Virtual Chassis Hardware Configuration on page 96](#)

Planning EX2300 Virtual Chassis

Before interconnecting EX2300 switches in a Virtual Chassis configuration, you must consider the following factors:

- The number of switches in the Virtual Chassis and their location—You can interconnect a maximum of four EX2300 switches to form a Virtual Chassis composed exclusively of EX2300 switches.
- Mounting—You can mount the switches in a single rack or install them on multiple racks. For information about the size and strength of racks, see [“Rack Requirements” on page 61](#).
- Cabling requirements for Virtual Chassis—You can interconnect EX2300 switches into a Virtual Chassis by using the uplink ports configured as Virtual Chassis ports (VCPs).

For information about uplink port cabling requirements, see [“Management Cable Specifications” on page 82](#).

- Power requirements—You must plan the installation site to meet the power requirements of the switches in a Virtual Chassis. See [“Power Specifications for EX2300 Switches” on page 69](#).
- License requirements—You must have license keys for all the devices. See *Understanding Software Licenses for EX Series Switches*.

**Related
Documentation**

- [Understanding EX Series Virtual Chassis Components](#)
- [Understanding EX2300 Virtual Chassis Hardware Configuration on page 96](#)
- [Clearance Requirements for Airflow and Hardware Maintenance for EX2300 Switches on page 64](#)

Understanding EX2300 Virtual Chassis Hardware Configuration

Virtual Chassis is a feature in Juniper Networks EX2300 Ethernet Switches that allows you to interconnect two or more EX2300 switches, enabling them to operate as a unified, single, high-bandwidth switch. You can interconnect a maximum of four EX2300 switches (including EX2300-C switches) by using the uplink ports configured as Virtual Chassis ports (VCPs) to form a Virtual Chassis.

All EX2300 switch models support Virtual Chassis, and you can interconnect different models, which allows you to choose among a range of possible port configurations within the same Virtual Chassis.

The Virtual Chassis configuration includes a master switch and a backup switch, with all other switches in the configuration designated as *linecard* member switches. Virtual Chassis operation is managed through the master switch. Each switch in the Virtual Chassis is assigned a unique member ID that is displayed on the switch LCD.

- Related Documentation**
- [Understanding EX Series Virtual Chassis Components](#)
 - [Planning EX2300 Virtual Chassis on page 95](#)

PART 3

Initial Installation and Configuration

- [Unpacking the Switch on page 99](#)
- [Installing the Switch on page 103](#)
- [Connecting the Switch to Power on page 133](#)
- [Connecting the Switch to the Network on page 147](#)
- [Performing Initial Configuration on page 153](#)

Unpacking the Switch

- [Unpacking an EX2300 Switch on page 99](#)
- [Parts Inventory \(Packing List\) for an EX2300 Switch on page 100](#)
- [Registering Products—Mandatory for Validating SLAs on page 101](#)

Unpacking an EX2300 Switch

EX2300 switches are shipped in a cardboard carton, secured with foam packing material. The carton also contains an accessory box.



CAUTION: EX Series switches are maximally protected inside the shipping carton. Do not unpack the switches until you are ready to begin installation.

To unpack the switch:

1. Move the shipping carton to a staging area as close to the installation site as possible, but where you have enough room to remove the system components.
2. Position the carton so that the arrows point up.
3. Open the top flaps on the shipping carton.
4. Remove the accessory box and verify the contents in it against the parts inventory on the label attached to the carton.
5. Pull out the packing material holding the switch in place.
6. Verify the chassis components received against the packing list included with the switch. An inventory of parts provided with the switch is provided in [“Parts Inventory \(Packing List\) for an EX2300 Switch” on page 100](#).
7. Save the shipping carton and packing materials in case you need to move or ship the switch later.

- Related Documentation**
- [Mounting an EX2300 Switch on page 104](#)
 - [Installing and Connecting an EX2300 Switch on page 103](#)
 - [Connecting and Configuring an EX Series Switch \(CLI Procedure\) on page 159](#)
 - [Connecting and Configuring an EX Series Switch \(J-Web Procedure\) on page 162](#)

Parts Inventory (Packing List) for an EX2300 Switch

EX2300 switches are shipped in a cardboard carton, secured with foam packing material. The carton also contains an accessory box.

The switch shipment includes a packing list. Check the parts you receive in the switch shipping carton against the items on the packing list. The parts shipped depend on the configuration you order.

If any part on the packing list is missing, contact your customer service representative or contact Juniper customer care from within the U.S. or Canada by telephone at 1-888-314-5822. For international-dial or direct-dial options in countries without toll-free numbers, see <http://www.juniper.net/support/requesting-support.html>.

[Table 50 on page 100](#) lists the parts and their quantities in the packing list.

Table 50: Parts List for EX2300 Switches

Component	Quantity
Switch with built-in power supply	1
AC power cord appropriate for your geographical location (only for AC switch models)	1
Power cord retainer clip (only for AC switch models except the EX2300-24MP model and the EX2300-48MP model)	1
Mounting brackets: <ul style="list-style-type: none"> • EX2300-C switch—separately orderable • EX2300 switch—provided 	2
Mounting screws to attach the mounting brackets to the switch chassis: <ul style="list-style-type: none"> • EX2300-C switch—separately orderable • EX2300 switch—provided 	8
Rubber feet (preinstalled on the chassis)	4
Ethernet cable with RJ-45 connectors attached and an RJ-45 to DB-9 serial port adapter—provided	1
Quick Start installation instructions	1
Paper license for Virtual Chassis (only for the models EX2300-C-12T-VC, EX2300-C-12P-VC, EX2300-24T-VC, EX2300-24P-VC, EX2300-48T-VC, and EX2300-48P-VC)	1

Table 50: Parts List for EX2300 Switches (*continued*)

Component	Quantity
Juniper Networks Product Warranty	1
End User License Agreement	1



NOTE: You must provide mounting screws that are appropriate for your rack or cabinet to mount the switch on a rack or a cabinet.

Related Documentation

- [Unpacking an EX2300 Switch on page 99](#)
- [EX2300 Switches Hardware Overview on page 3](#)

Registering Products—Mandatory for Validating SLAs

Register all new Juniper Networks hardware products and changes to an existing installed product using the Juniper Networks website to activate your hardware replacement service-level agreements (SLAs).



CAUTION: Register product serial numbers on the Juniper Networks website and update the installation base data if there is any addition or change to the installation base or if the installation base is moved. Juniper Networks will not be held accountable for not meeting the hardware replacement service-level agreement for products that do not have registered serial numbers or accurate installation base data.

Register your product(s) at: <https://tools.juniper.net/svcreg/SRegSerialNum.jsp>.

Update your install base at:

<https://www.juniper.net/customers/csc/management/updateinstallbase.jsp>.

Related Documentation

- [Contacting Customer Support to Obtain Return Material Authorization on page 187](#)
- [Contacting Customer Support to Obtain a Return Materials Authorization for an MX150](#)

CHAPTER 12

Installing the Switch

- [Installing and Connecting an EX2300 Switch on page 103](#)
- [Mounting an EX2300 Switch on page 104](#)
- [Mounting an EX2300 Switch on a Desk or Other Level Surface on page 105](#)
- [Mounting an EX2300-C Switch Under a Desk or Other Level Surface by Using Screws on page 107](#)
- [Mounting an EX2300 Switch on Two Posts of a Rack or Cabinet on page 112](#)
- [Mounting an EX2300 Switch on Four Posts of a Rack or Cabinet on page 114](#)
- [Mounting an EX2300 Switch on a Wall on page 118](#)
- [Mounting an EX2300-C Switch on or Under a Surface Made of Ferrous Material on page 126](#)
- [Mounting an EX2300 Switch in a Recessed Position in a Rack or Cabinet on page 131](#)

Installing and Connecting an EX2300 Switch

To install and connect an EX2300 switch:

1. Follow instructions in [“Unpacking an EX2300 Switch” on page 99](#).
2. Mount the switch by following instructions appropriate for your site:
 - [“Mounting an EX2300 Switch on a Desk or Other Level Surface” on page 105](#) (using the rubber feet preinstalled on the chassis)
 - [“Mounting an EX2300-C Switch Under a Desk or Other Level Surface by Using Screws” on page 107](#) (using the desk-mounting screws)
 - [“Mounting an EX2300 Switch on a Wall” on page 118](#) (using the wall-mounting screws for EX2300-C switches and using the separately orderable wall-mount kit for EX2300 switches except EX2300-24MP and EX2300-48MP models)
 - [“Mounting an EX2300-C Switch on or Under a Surface Made of Ferrous Material” on page 126](#) (using the separately orderable magnet-mount kit)
 - [“Mounting an EX2300 Switch on Two Posts of a Rack or Cabinet” on page 112](#) (using the mounting brackets separately orderable for EX2300-C switches and provided for EX2300 switches)

- [“Mounting an EX2300 Switch on Four Posts of a Rack or Cabinet”](#) on page 114 (using the separately orderable four-post rack-mount kit)
 - [“Mounting an EX2300 Switch in a Recessed Position in a Rack or Cabinet”](#) on page 131 (using the 2-in.-recess front-mounting brackets from the separately orderable four-post rack-mount kit)
3. Follow instructions in [“Connecting Earth Ground to an EX Series Switch”](#) on page 133.
 4. Follow instructions in [“Connecting AC Power to an EX2300 Switch”](#) on page 140.
 5. Perform initial configuration of the switch by following instructions in [“Connecting and Configuring an EX Series Switch \(CLI Procedure\)”](#) on page 159 or [“Connecting and Configuring an EX Series Switch \(J-Web Procedure\)”](#) on page 162.

Set the switch's management options by following the appropriate instructions:

- [Connecting a Device to a Network for Out-of-Band Management](#) on page 147
- [Connecting a Device to a Management Console by Using an RJ-45 Connector](#) on page 148

Related Documentation

- [Rack Requirements](#) on page 61
- [Cabinet Requirements](#) on page 63
- [Clearance Requirements for Airflow and Hardware Maintenance for EX2300 Switches](#) on page 64

Mounting an EX2300 Switch

[Table 51](#) on page 104 lists the methods you can use to mount an EX2300 switch.

Table 51: EX2300 Switch Mounting Methods

Mounting Method	Switch Model	More Information
Desk or other level surface (using the rubber feet preinstalled on the chassis)	<ul style="list-style-type: none"> • EX2300-C • EX2300 	On a desk or other level surface by using the rubber feet preinstalled on the chassis
Desk or other level surface (using screws)	EX2300-C	On or under a desk or other level surface by using screws
Wall	EX2300-C	On a wall by using screws
	EX2300 except the EX2300-24MP and EX2300-48MP models	On a wall by using the separately orderable wall-mount kit
A surface made of ferrous material	EX2300-C	On or under a surface made of ferrous material by using the separately orderable magnet-mount kit

Table 51: EX2300 Switch Mounting Methods (*continued*)

Mounting Method	Switch Model	More Information
Two-post rack or cabinet	<ul style="list-style-type: none"> EX2300-C EX2300 	On two posts in a 19-in. rack or cabinet by using the mounting brackets (separately orderable for EX2300-C switches and provided for EX2300 switches)
Four-post rack or cabinet	EX2300-C	On two posts in a 19-in. rack-mounting brackets or cabinet by using the separately orderable two-post rack-mounting brackets
	EX2300	On four posts in a 19-in. rack-mounting brackets or cabinet by using the separately orderable four-post rack-mount kit
Recessed position	EX2300	In a position recessed 2 in. from the front of a 19-in. rack or cabinet by using the 2-in.-recess front-mounting brackets in the separately orderable four-post rack-mount kit. You can mount the switch in this recessed position on two-post or four-post racks and cabinets.

The holes in the mounting brackets are placed 1 U (1.75 in. or 4.45 cm) apart so that the switch can be mounted in any rack or cabinet that provides holes spaced at that distance.

Related Documentation

- [Mounting an EX2300 Switch on a Desk or Other Level Surface on page 105](#)
- [Mounting an EX2300-C Switch Under a Desk or Other Level Surface by Using Screws on page 107](#)
- [Mounting an EX2300 Switch on a Wall on page 118](#)
- [Mounting an EX2300-C Switch on or Under a Surface Made of Ferrous Material on page 126](#)
- [Mounting an EX2300 Switch on Two Posts of a Rack or Cabinet on page 112](#)
- [Mounting an EX2300 Switch on Four Posts of a Rack or Cabinet on page 114](#)
- [Mounting an EX2300 Switch in a Recessed Position in a Rack or Cabinet on page 131](#)
- [Connecting Earth Ground to an EX Series Switch on page 133](#)

Mounting an EX2300 Switch on a Desk or Other Level Surface

You can mount an EX2300 switch on a desk or other level surface by using the four rubber feet that are preinstalled on the switch. The rubber feet stabilize the chassis.

Before mounting the switch on a desk or other level surface:

- Verify that the site meets the requirements described in “[Site Preparation Checklist for EX2300 Switches](#)” on page 53.
- Place the desk in its permanent location, allowing adequate clearance for airflow and maintenance, and secure it to the building structure.
- Read “[General Safety Guidelines and Warnings](#)” on page 213, with particular attention to “[Chassis Lifting Guidelines](#)” on page 222.



NOTE: Do not block the vents on the top of EX2300-C switches. Blocking the vents can lead to overheating of the switch chassis.

Ensure that you have the following parts and tools available:

- (Optional and separately orderable; applies only to EX2300-C switches) 1 cable guard kit. The kit includes the cable guard and 3 number-8 Phillips truss-head screws to secure the cable guard to the EX2300-C switch
- (Optional and separately orderable; applies only to EX2300-C switches) 1 standard cable lock kit to secure the EX2300-C switch from theft by connecting the cable to the security slot on the switch and a desk or a rack to fasten the cable lock. The kit includes the standard cable lock and its key.

To mount a switch on a desk or other level surface:

1. Remove the switch from the shipping carton (see “[Unpacking an EX2300 Switch](#)” on [page 99](#)).
2. (Optional; applies only to EX2300-C switches) Attach the cable guard to protect cable connections:
 - a. Use the 3 truss-head screws to attach the cable guard to the bottom of the chassis.
 - b. Use the thumbscrews to tighten or loosen the cable guard so that you can insert cables. See [Figure 31 on page 106](#).

Figure 31: Attaching a Cable Guard to an EX2300-C Switch

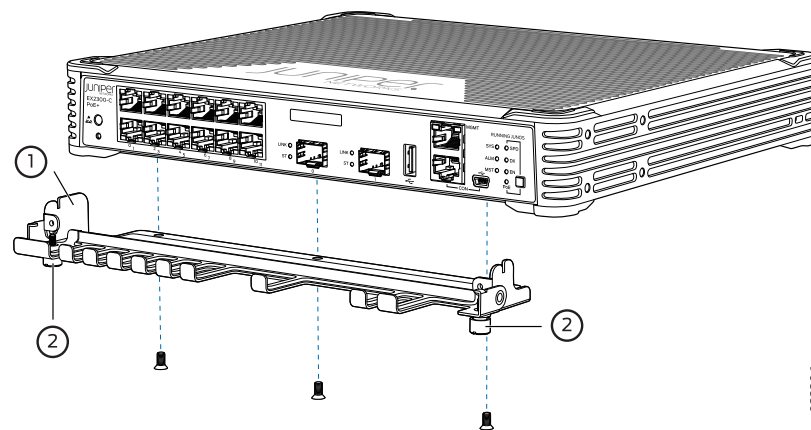

8022206

1—Cable guard

2—Thumb screws

3. Place the switch on the desk or the level surface.

4. Ensure that the switch rests firmly on the desk or level surface.
5. (Optional; applies only to EX2300-C switches) Attach the standard cable lock to the security slot on the switch:
 - a. Fasten the cable to a desk or a rack and set the lock to unlocked position using the key.
 - b. Insert the lock into the security slot on the switch and set the lock to the locked position using the key. See [Figure 32 on page 107](#).

Figure 32: Securing the EX2300-C Switch by Using the Security Slot

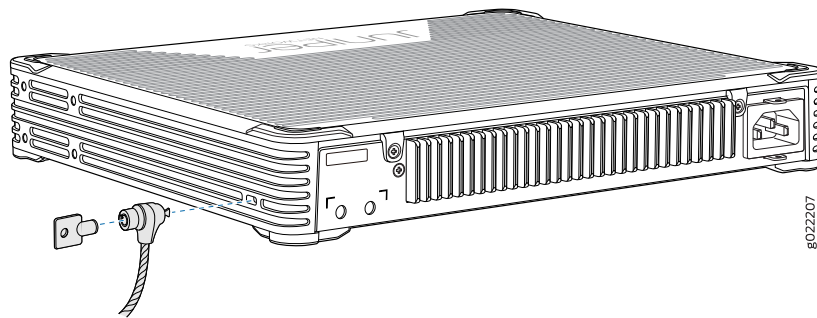

Related Documentation

- [Connecting AC Power to an EX2300 Switch on page 140](#)
- [Connecting DC Power to an EX2300 Switch on page 143](#)
- [Connecting and Configuring an EX Series Switch \(CLI Procedure\) on page 159](#)
- [Connecting and Configuring an EX Series Switch \(J-Web Procedure\) on page 162](#)
- [Clearance Requirements for Airflow and Hardware Maintenance for EX2300 Switches on page 64](#)

Mounting an EX2300-C Switch Under a Desk or Other Level Surface by Using Screws

You can mount an EX2300-C switch under a desk or other level surface by using the mounting slots on the bottom of the chassis and desk-mounting screws to secure the switch.

Before mounting the switch under a desk or other level surface by using screws:

- Verify that the site meets the requirements described in "[Site Preparation Checklist for EX2300 Switches](#)" on page 53.
- Place the desk in its permanent location, allowing adequate clearance for airflow and maintenance, and secure it to the building structure.

- Read “General Safety Guidelines and Warnings” on page 213, with particular attention to “Chassis Lifting Guidelines” on page 222.
- Remove the switch from the shipping carton (see “Unpacking an EX2300 Switch” on page 99).



NOTE: Do not block the vents on the top of EX2300-C switches. Blocking the vents can lead to overheating of the switch chassis.

Ensure that you have the following parts and tools available:

- 3 desk-mounting screws (M4 x 30 mm or 8-32 x 1.25 in. Phillips pan-head machine screws—not provided)
- Phillips (+) screwdriver, number 2
- (Optional and separately orderable) 1 cable guard kit. The kit includes the cable guard and 3 number-8 Phillips truss-head screws to secure the cable guard to the switch.
- (Optional and separately orderable) 1 standard cable lock kit to secure the switch from theft by connecting the cable to the security slot on the switch and a desk or a rack to fasten the cable lock. The kit includes the standard cable lock and its key.

To mount the switch under a desk or other level surface by using screws:

1. Remove the switch from the shipping carton (see “Unpacking an EX2300 Switch” on page 99).
2. (Optional) Attach the cable guard to protect cable connections:
 - a. Use the 3 truss-head screws to attach the cable guard to the bottom of the chassis.
 - b. Use the thumbscrews to fasten or loosen the cable guard so that you can insert cables. See [Figure 33 on page 109](#).

Figure 33: Attaching a Cable Guard to an EX2300-C Switch

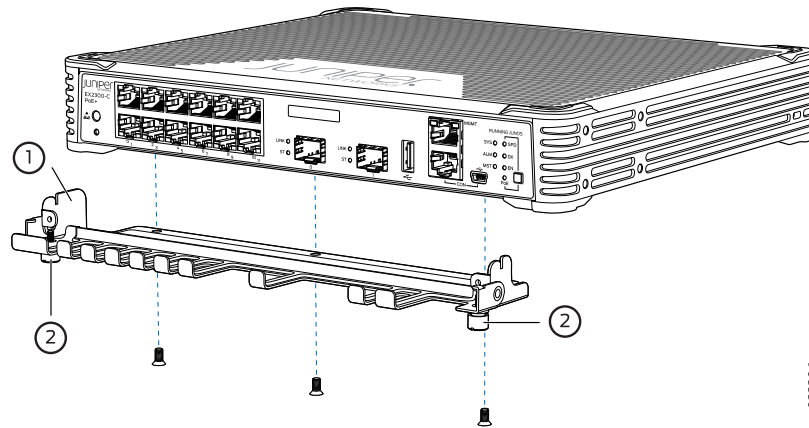

1— Cable guard

2— Thumb screws

3. Install three mounting screws under the desk or the level surface at the locations A, B, and C shown in [Figure 34 on page 110](#).



NOTE: [Figure 34 on page 110](#) shows the bottom panel of an EX2300-C switch when the switch is viewed from the top. The internal components and top cover are not shown.

Figure 34: Measurements for Installing Mounting Screws for Mounting EX2300-C Switches Under a Desk or Other Level Surface by Using Screws

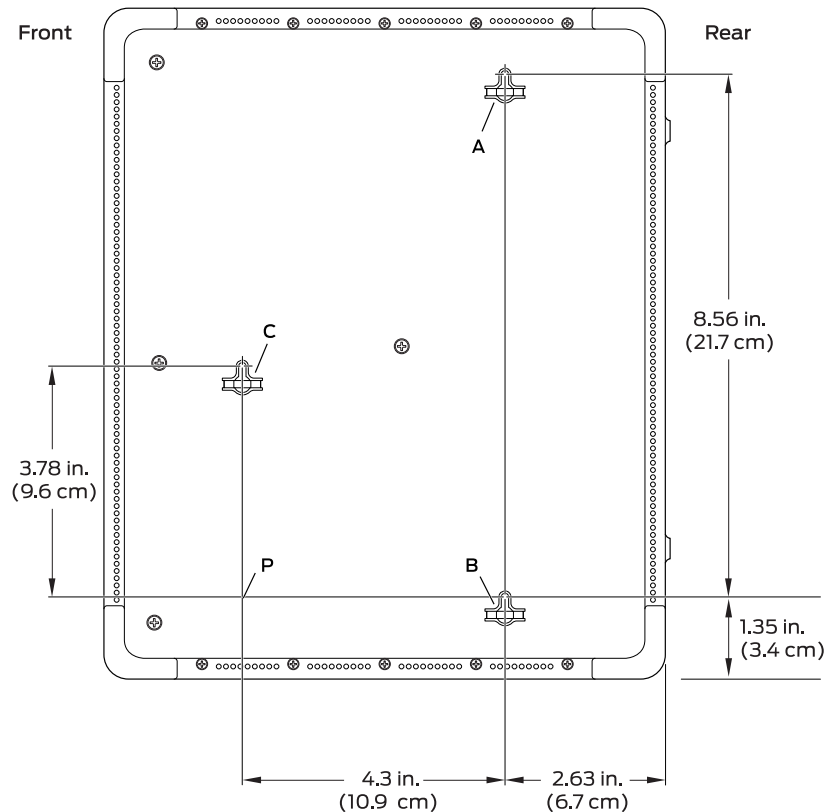

NOTE: Tighten the screws only part way in, leaving about 1/4 in. (6 mm) distance between the head of the screw and the desk or the level surface.

- a. Drill a hole A and install a mounting screw.
 - b. Drill a hole B at a distance of 8.56 in. (21.7 cm) on a level line from hole A and install a mounting screw.
 - c. Mark a point P at a distance of 4.3 in. (10.9 cm) on a level line to the right from hole B.
 - d. Drill a hole C at a distance of 3.78 in. (9.6 cm) on a level line from point P and install a mounting screw.
4. For mounting the switch under a desk or other level surface, hold the switch such that the holes on the bottom panel of the switch align with the screw heads, lift the switch, and then slide the switch forward or backward until it locks in place. See [Figure 35 on page 111](#).

Figure 35: Mounting the EX2300-C Switch Under a Desk or Other Level Surface by Using Screws

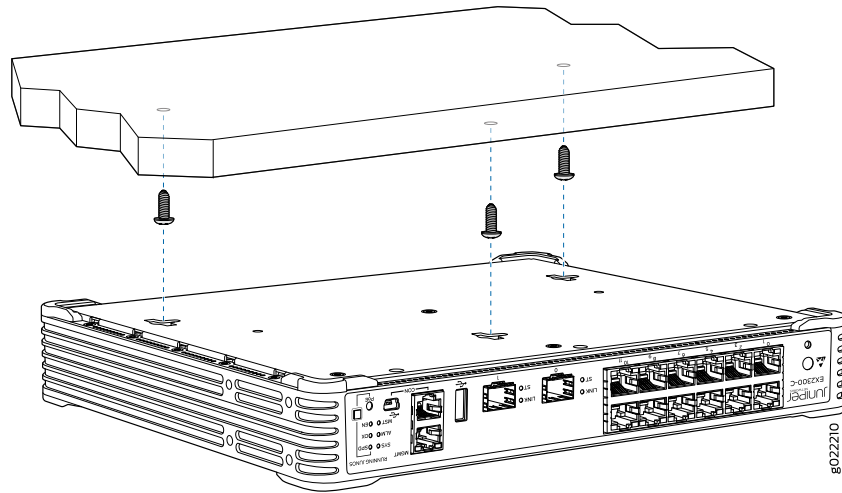

5. (Optional) Attach the standard cable lock to the security slot on the switch:
 - a. Fasten the cable to a desk or a rack and set the lock to unlocked position using the key.
 - b. Insert the lock into the security slot on the switch and set the lock to the locked position using the key. See [Figure 36 on page 111](#).

Figure 36: Securing the EX2300-C Switch by Using the Security Slot

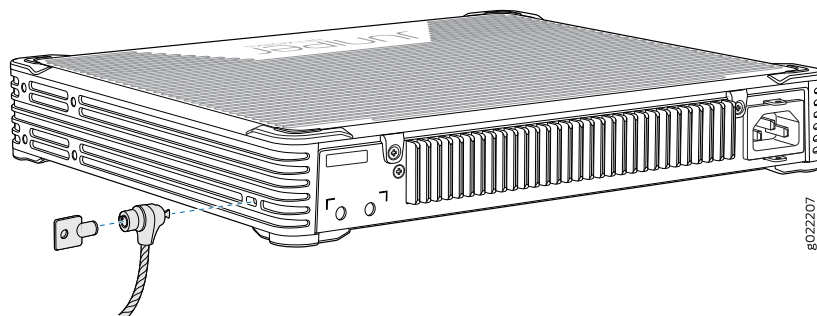

Related Documentation

- [Connecting AC Power to an EX2300 Switch on page 140](#)
- [Connecting and Configuring an EX Series Switch \(CLI Procedure\) on page 159](#)
- [Connecting and Configuring an EX Series Switch \(J-Web Procedure\) on page 162](#)

Mounting an EX2300 Switch on Two Posts of a Rack or Cabinet

You can mount all EX2300 switches on two posts of a two-post or a four-post 19-in. rack or cabinet by using the mounting brackets and screws provided with EX2300 switches except the EX2300-C switch models. For EX2300-C switches, mounting brackets and screws are separately orderable. The remainder of this topic uses *rack* to mean *rack or cabinet*.



NOTE: If you need to mount an EX2300 switch except the EX2300-C switch models in a recessed position on either a two-post rack or a four-post rack, you can use the 2-in.-recess front-mounting brackets provided in the separately orderable four-post rack-mount kit. EX2300-C cannot be mounted in a recessed position.



NOTE: Do not block the vents on the top of EX2300-C switches. Blocking the vents can lead to overheating of the switch chassis.

Before mounting the switch on two posts of a two-post or a four-post rack:

- Verify that the site meets the requirements described in “[Site Preparation Checklist for EX2300 Switches](#)” on page 53.
- Place the rack in its permanent location, allowing adequate clearance for airflow and maintenance, and secure it to the building structure.
- Read “[General Safety Guidelines and Warnings](#)” on page 213, with particular attention to “[Chassis Lifting Guidelines](#)” on page 222.

Ensure that you have the following parts and tools available:

- Phillips (+) screwdriver, number 2
- 2 mounting brackets and 8 mounting screws (provided with EX2300 switches except the EX2300-C switch model and separately orderable for EX2300-C switches)
- Screws to secure the chassis to the rack (not provided)
- 2-in.-recess front-mounting brackets from the separately orderable four-post rack-mount kit if you will mount the switch in a recessed position (not applicable for EX2300-C switches)



NOTE: One person must be available to lift the switch while another secures the switch to the rack.



CAUTION: If you are mounting multiple units on a rack, mount the heaviest unit at the bottom of the rack and mount the other units from the bottom of the rack to the top in decreasing order of the weight of the units.

To mount the switch on two posts of a two-post or a four-post rack:

1. Remove the switch from the shipping carton (see “[Unpacking an EX2300 Switch](#)” on [page 99](#)).
2. Place the switch on a flat, stable surface.
3. Align the mounting brackets along the front or rear of the side panels of the switch chassis depending on how you want to mount the switch. For example, if you want to front-mount the switch, align the brackets along the front of the chassis. [Figure 37 on page 113](#) shows how to attach the mounting brackets along the front of the EX2300 switch.

Figure 37: Attaching the Mounting Bracket Along the Front of the Switch

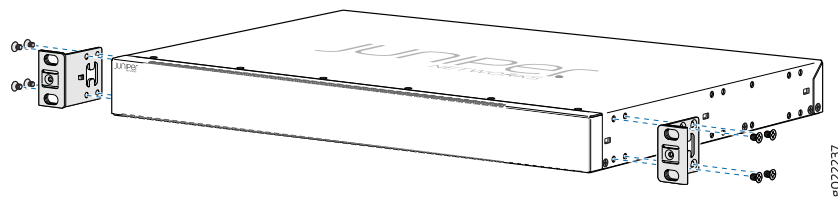

NOTE: The length of the mounting brackets depends on the switch model.

4. Align the bottom holes in the mounting brackets with the holes on the side panels of the switch chassis.
5. Insert the mounting screws into the aligned holes. Tighten the screws.
6. Ensure that the other holes in the mounting brackets are aligned with the holes in the side panels. Insert a screw in each hole and tighten the screws.
7. Have one person grasp both sides of the switch, lift the switch, and position it in the rack, aligning the mounting bracket holes with the threaded holes in the rack rail. Align the bottom hole in each mounting bracket with a hole in each rack rail, making sure the chassis is level. See [Figure 38 on page 114](#).

Figure 38: Mounting the Switch on Two Posts of a Rack

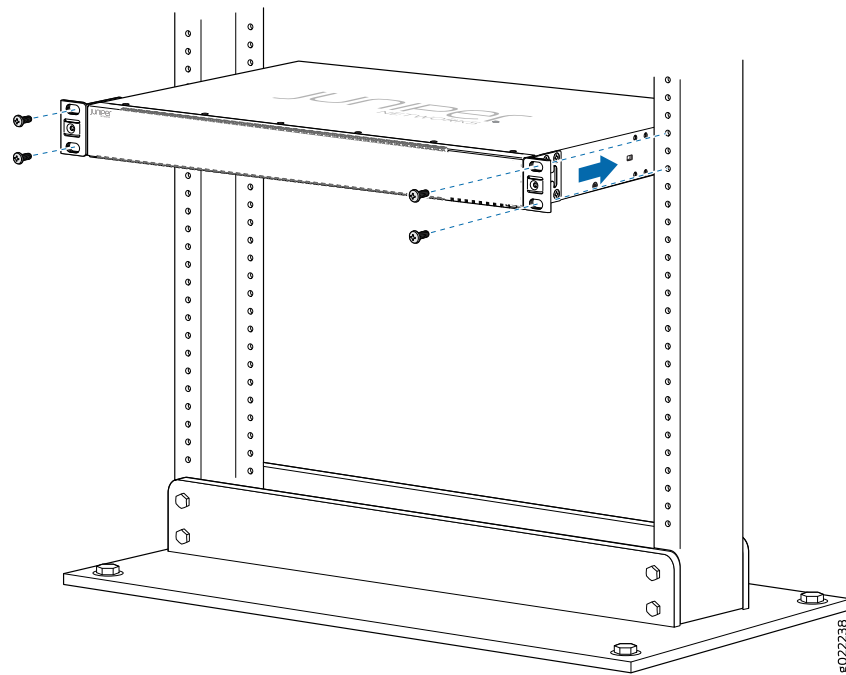

8. Have a second person secure the switch to the rack by using the appropriate screws. Tighten the screws.
9. Ensure that the switch chassis is level by verifying that all screws on one side of the rack are aligned with the screws on the other side.

Related Documentation

- [Mounting an EX2300 Switch on Four Posts of a Rack or Cabinet on page 114](#)
- [Connecting Earth Ground to an EX Series Switch on page 133](#)
- [Connecting AC Power to an EX2300 Switch on page 140](#)
- [Connecting DC Power to an EX2300 Switch on page 143](#)
- [Connecting and Configuring an EX Series Switch \(CLI Procedure\) on page 159](#)
- [Connecting and Configuring an EX Series Switch \(J-Web Procedure\) on page 162](#)
- [Mounting an EX2300 Switch in a Recessed Position in a Rack or Cabinet on page 131](#)
- [Rack-Mounting and Cabinet-Mounting Warnings on page 224](#)

Mounting an EX2300 Switch on Four Posts of a Rack or Cabinet

You can mount an EX2300 switch except the EX2300-C switch model on four posts of a 19-in. rack or cabinet by using the separately orderable four-post rack-mount kit. The remainder of this topic uses *rack* to mean *rack or cabinet*.



NOTE: EX2300-C switches cannot be mounted on all four posts of a rack.



NOTE: If you need to mount an EX2300 switch except the EX2300-C switch model in a recessed position on either a two-post rack or a four-post rack, you can use the 2-in.-recess front-mounting brackets provided in the separately orderable four-post rack-mount kit. EX2300-C switches cannot be mounted in a recessed position.

Before mounting the switch on four posts of a rack:

- Verify that the site meets the requirements described in “[Site Preparation Checklist for EX2300 Switches](#)” on page 53.
- Place the rack in its permanent location, allowing adequate clearance for airflow and maintenance, and secure it to the building structure.
- Read “[General Safety Guidelines and Warnings](#)” on page 213, with particular attention to “[Chassis Lifting Guidelines](#)” on page 222.

Ensure that you have the following parts and tools available:

- Phillips (+) screwdriver, number 2
- 6 Phillips 4-40 flat-head mounting screws (provided with the four-post rack-mount kit)
- 8 Phillips 4x6-mm flat-head mounting screws (provided with the four-post rack-mount kit)
- One pair each of flush or 2-in.-recess front-mounting brackets
- One pair of side mounting-rails
- One pair of rear mounting-blades
- Screws to secure the chassis and the rear mounting-blades to the rack (not provided)



NOTE: One person must be available to lift the switch while another secures it to the rack.



CAUTION: If you are mounting multiple units on a rack, mount the heaviest unit at the bottom of the rack and mount the other units from the bottom of the rack to the top in decreasing order of the weight of the units.

To mount the switch on four posts of a rack:

1. Remove the switch from the shipping carton (see [“Unpacking an EX2300 Switch”](#) on page 99).
2. Attach the front-mounting brackets (either the flush or the 2-in.-recess brackets) to the side mounting-rails by using 6 Phillips 4-40 flat-head mounting screws. See [Figure 39](#) on page 116.

Figure 39: Attaching the Front-Mounting Bracket to the Side Mounting-Rail

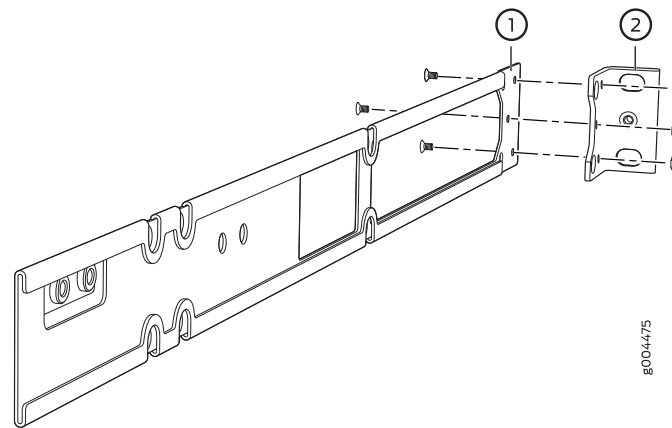

1— Side mounting-rail

2— Front-mounting bracket

3. Place the switch on a flat, stable surface.
4. Align the side mounting-rails along the side panels of the switch chassis. Align the two holes in the rear of the side mounting-rails with the two holes on the rear of the side panel.
5. Insert the Phillips 4x6-mm flat-head mounting screws into the two aligned holes and tighten the screws. Ensure that the two holes in the rear of the side mounting-rails are aligned with the remaining two holes in the side panel. See [Figure 40](#) on page 116.
6. Insert the Phillips 4x6-mm flat-head mounting screws into the remaining two holes in the side mounting-rails and tighten the screws.
7. Have one person grasp both sides of the switch, lift the switch, and position it in the rack, aligning the side mounting-rail holes with the threaded holes in the front post of the rack. Align the bottom hole in both the front-mounting brackets with a hole in each rack rail, making sure that the chassis is level. See [Figure 41](#) on page 117.

Figure 41: Mounting the Switch to the Front Posts of a Rack

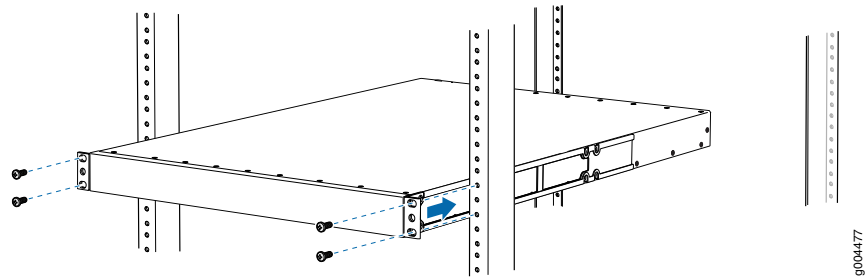

8. Have a second person secure the front of the switch to the rack by using the appropriate screws for your rack.

9. Slide the rear mounting-blades into the side mounting-rails. See [Figure 42 on page 117](#).

Figure 42: Sliding the Rear Mounting-Blades into the Side Mounting-Rail

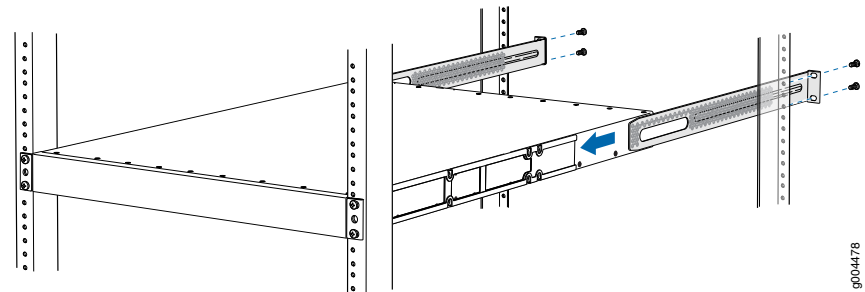

10. Attach the rear mounting-blades to the rear post by using the appropriate screws for your rack. Tighten the screws.

11. Ensure that the switch chassis is level by verifying that all the screws on the front of the rack are aligned with the screws at the back of the rack.

Related Documentation

- [Mounting an EX2300 Switch on Two Posts of a Rack or Cabinet on page 112](#)
- [Connecting Earth Ground to an EX Series Switch on page 133](#)
- [Connecting AC Power to an EX2300 Switch on page 140](#)
- [Connecting DC Power to an EX2300 Switch on page 143](#)
- [Connecting and Configuring an EX Series Switch \(CLI Procedure\) on page 159](#)
- [Connecting and Configuring an EX Series Switch \(J-Web Procedure\) on page 162](#)
- [Mounting an EX2300 Switch in a Recessed Position in a Rack or Cabinet on page 131](#)
- [Rack-Mounting and Cabinet-Mounting Warnings on page 224](#)

Mounting an EX2300 Switch on a Wall

This topic describes the process of mounting an EX2300 switch on a wall. You can mount EX2300 switches except the EX2300-24MP and EX2300-48MP models on a wall.

1. [Mounting an EX2300-C Switch on a Wall on page 118](#)
2. [Mounting an EX2300 Switch Except the EX2300-24MP and EX2300-48MP Models and the EX2300-C Switch on a Wall on page 122](#)

Mounting an EX2300-C Switch on a Wall

You can mount an EX2300-C switch—the compact, fanless model—on a wall by using the mounting slots on the bottom of the chassis and mounting screws to secure the switch.

Before mounting the switch on a wall:

- Verify that the site meets the requirements described in [“Site Preparation Checklist for EX2300 Switches” on page 53](#).
- Read [“General Safety Guidelines and Warnings” on page 213](#), with particular attention to [“Chassis Lifting Guidelines” on page 222](#).

Ensure that you have the following parts and tools available:

- 3 wall-mounting screws (M4 x 30 mm or 8-32 x 1.25 in. Phillips pan-head machine screws—not provided)
- Phillips (+) screwdriver, number 2
- Hollow wall anchors rated to support up to 75 lb (34 kg) if you are not inserting the mounting screws directly into wall studs.
- (Optional and separately orderable) 1 cable guard kit. The kit includes the cable guard and 3 number-8 Phillips truss-head screws to secure the cable guard to the EX2300-C switch.
- (Optional and separately orderable) 1 standard cable lock kit to secure the switch from theft by connecting the cable to the security slot on the switch and a desk or a rack to fasten the cable lock. The kit includes the standard cable lock and its key.

To mount the switch on a wall:

1. Remove the switch from the shipping carton (see [“Unpacking an EX2300 Switch” on page 99](#)).
2. (Optional) Attach the optional cable guard to protect cable connections:
 - a. Use the 3 truss-head screws to attach the cable guard to the bottom of the chassis.
 - b. Use the thumbscrews to fasten or loosen the cable guard so that you can insert cables. See [Figure 43 on page 119](#).

Figure 44: Measurements for Installing Mounting Screws for Mounting an EX2300-C Switch on a Wall

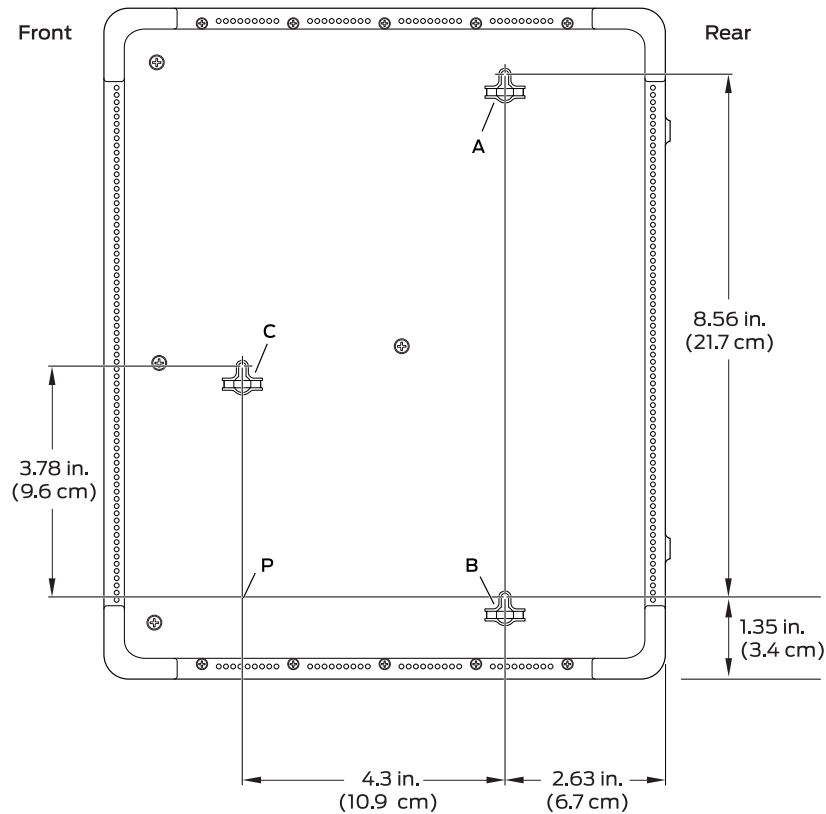

NOTE: Tighten the screws only part way in, leaving about 1/4 in. (6 mm) distance between the head of the screw and the wall.

- a. Drill a hole A and install a mounting screw.
 - b. Drill a hole B at a distance of 8.56 in. (21.7 cm) on a plumb line from hole A and install a mounting screw.
 - c. Mark a point P at a distance of 4.3 in. (10.9 cm) on a level line to the right from hole B.
 - d. Drill a hole C at a distance of 3.78 in. (9.6 cm) on a level line to the top from point P and install a mounting screw.
4. Place the switch against the wall such that the front panel of the switch faces to the right side and the holes on the bottom panel of the switch align with the mounting screw heads.

5. Slide the switch chassis to the left or right a bit so that the mounting screws are pushed into the channels of the holes on the bottom panel until the switch rests firmly in place as shown in [Figure 45 on page 121](#).
6. Slide the switch chassis to the left or right a bit so that the mounting screws are pushed into the channels of the holes on the bottom panel until the switch locks firmly in place as shown in [Figure 45 on page 121](#).

Figure 45: Mounting an EX2300-C Switch on a Wall

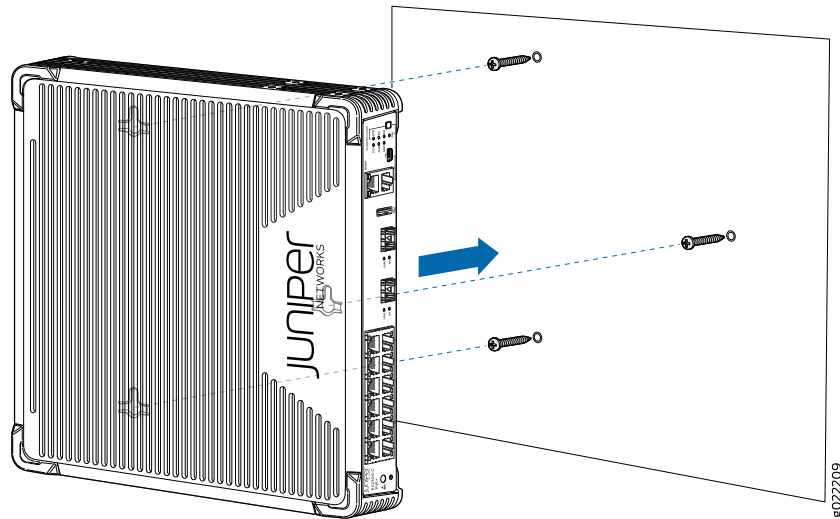

7. (Optional) Attach the optional standard cable lock to the security slot on the side of the switch:
 - a. Fasten the cable to a desk or a rack and set the lock to the unlocked position.
 - b. Insert the lock into the security slot on your chassis and set the lock to the locked position using the key. See [Figure 46 on page 121](#).

Figure 46: Securing the EX2300-C Switch by Using the Security Slot

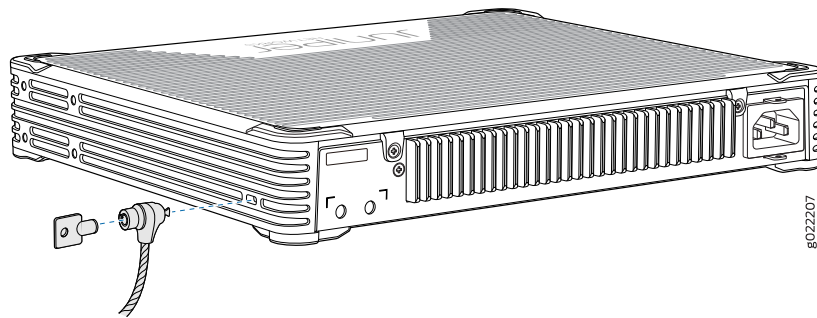

Mounting an EX2300 Switch Except the EX2300-24MP and EX2300-48MP Models and the EX2300-C Switch on a Wall

You can mount an EX2300 switch except the EX2300-24MP and EX2300-48MP models and the EX2300-C switch on a wall by using the separately orderable wall-mount kit.

Before mounting the switch on a wall:

- Verify that the site meets the requirements described in [“Site Preparation Checklist for EX2300 Switches”](#) on page 53.
- Read [“General Safety Guidelines and Warnings”](#) on page 213, with particular attention to [“Chassis Lifting Guidelines”](#) on page 222.

Ensure that you have the following parts and tools available:

- 2 wall-mounting brackets (provided in the wall-mount kit)
- 12 wall-mounting bracket screws (provided in the wall-mount kit)
- 6 mounting screws (8-32 x 1.25 in. or M4 x 30 mm) (not provided)
- Hollow wall anchors rated to support up to 75 lb (34 kg) if you are not screwing the screws directly into wall studs (not provided)
- Phillips (+) screwdriver, number 2

To mount the switch on a wall:

1. Remove the switch from the shipping carton (see [“Unpacking an EX2300 Switch”](#) on page 99).
2. Attach the wall-mounting brackets to the sides of the chassis by using four wall-mounting bracket screws, as shown in [Figure 47](#) on page 123.

Figure 47: Attaching Wall-Mount Brackets to an EX2300 Switch Except the EX2300-24MP and EX2300-48MP Models and the EX2300-C Switch

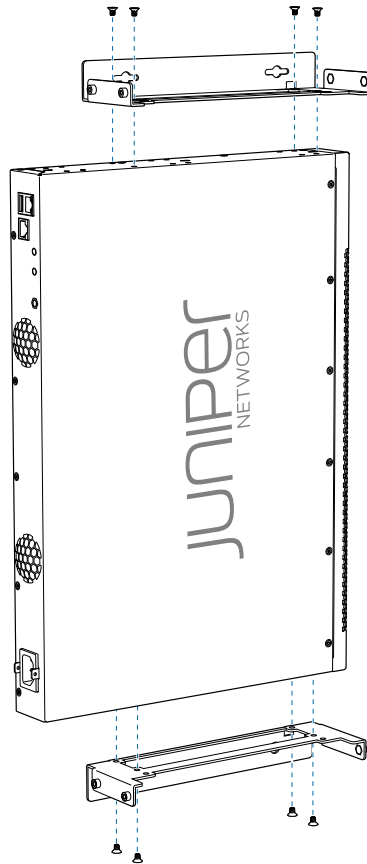

3. Install four mounting screws for the wall-mounting brackets on the wall as shown in [Figure 48 on page 125](#).



NOTE: Figure 48 on page 125 shows an EX2300 switch with 24 ports with PoE capability when the switch is viewed from the top. The internal components and top cover are not shown. The procedure to mount the switch on a wall and the distance between mounting screws are the same for EX2300 switches with 24 ports with and without PoE capability though the depth of the chassis of the switches with and without PoE capability are different.



NOTE: Tighten the screws only part way in, leaving about 1/4 in. (6 mm) distance between the head of the screw and the wall.

- a. Drill a hole A and install a mounting screw.
- b. Drill a hole B at a distance of 5.98 in. (15.2 cm) on a level line to the right from screw A and install a mounting screw.
- c. Drill a hole C at a distance of 18.67 in. (47.43 cm) on a plumb line down from screw A and install a mounting screw.
- d. Drill a hole D at a distance of 18.67 in. (47.43 cm) on a plumb line down from screw B and install a mounting screw.

Figure 48: Measurements for Installing Mounting Screws to Mount an EX2300 Switch Except the EX2300-24MP and EX2300-48MP Models and the EX2300-C Switch on a Wall

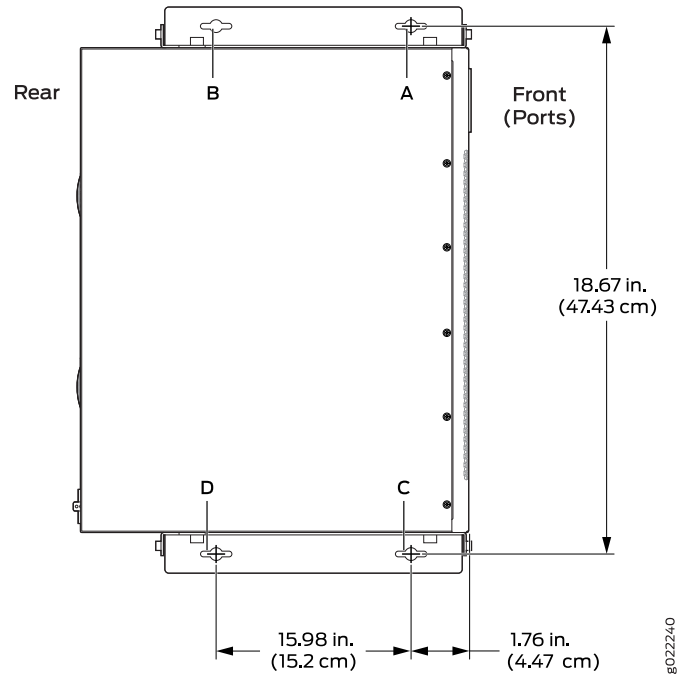

4. Place the switch against the wall such that the front panel of the switch faces to the right side and the holes in the mounting brackets heads align with the mounting screw heads.
5. Slide the switch chassis to the left or right a bit so that the mounting screws are pushed into the channels of the holes in the mounting brackets until the switch rests firmly in place as shown in [Figure 49 on page 126](#).
6. Tighten the mounting screws.

Figure 49: Mounting an EX2300 Switch Except the EX2300-24MP and EX2300-48MP Models and the EX2300-C Switch on a Wall

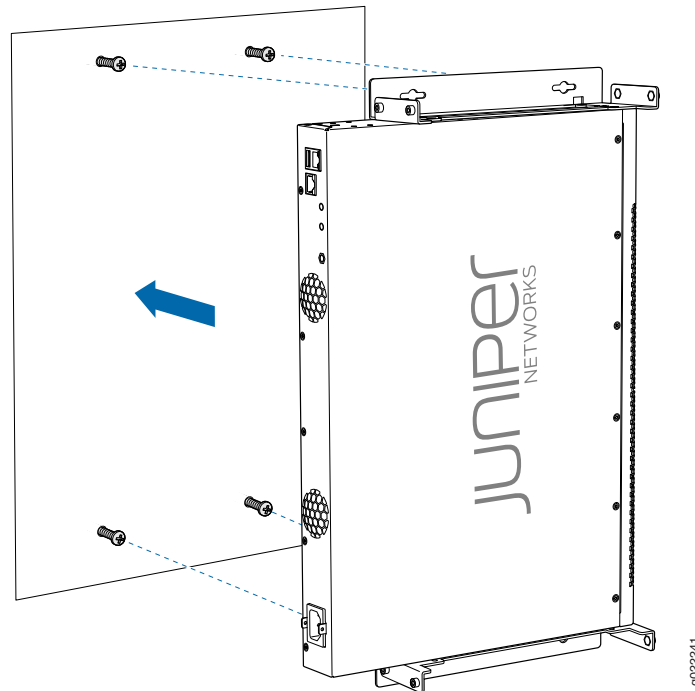

Related Documentation

- [Connecting AC Power to an EX2300 Switch on page 140](#)
- [Connecting and Configuring an EX Series Switch \(CLI Procedure\) on page 159](#)
- [Connecting and Configuring an EX Series Switch \(J-Web Procedure\) on page 162](#)

Mounting an EX2300-C Switch on or Under a Surface Made of Ferrous Material

You can mount an EX2300-C switch on or under a surface made of ferrous material by using the separately orderable magnet-mount kit.



WARNING: Do not mount EX2300-C switches on a ceiling by using the separately orderable magnet-mount kit.



NOTE: Do not block the vents on the top of EX2300-C switches. Blocking the vents can lead to overheating of the switch chassis.

Before mounting the switch on or under a surface made of ferrous material:

- Verify that the site meets the requirements described in [“Site Preparation Checklist for EX2300 Switches” on page 53](#).
- Place the surface made of ferrous material in its permanent location, allowing adequate clearance for airflow and maintenance.
- Read [“General Safety Guidelines and Warnings” on page 213](#), with particular attention to [“Chassis Lifting Guidelines” on page 222](#).

Ensure that you have the following parts and tools available:

- Magnet-mount kit (separately orderable). The kit includes 2 self adhesive rubber pads and 1 magnet mount sheet.
- At least 2-mm thick flat surface made of ferrous material (not provided)
- (Optional and separately orderable) 1 cable guard kit. The kit includes the cable guard and 3 number-8 Phillips truss-head screws to secure the cable guard to the EX2300-C switch.
- (Optional and separately orderable) 1 standard cable lock kit to secure the switch from theft by connecting the cable to the security slot on the switch and a desk or a rack to fasten the cable lock. The kit includes the standard cable lock and its key.

To mount the switch on or under a surface made of ferrous material:

1. Remove the switch from the shipping carton (see [“Unpacking an EX2300 Switch” on page 99](#)).
2. Turn the chassis upside down.
3. (Optional) Attach the cable guard to protect cable connections:
 - a. Use the 3 truss-head screws to attach the cable guard to the bottom of the chassis.
 - b. Use the thumbscrews to tighten or loosen the cable guard so that you can insert cables. See [Figure 50 on page 128](#).

Figure 50: Attaching a Cable Guard to an EX2300-C Switch

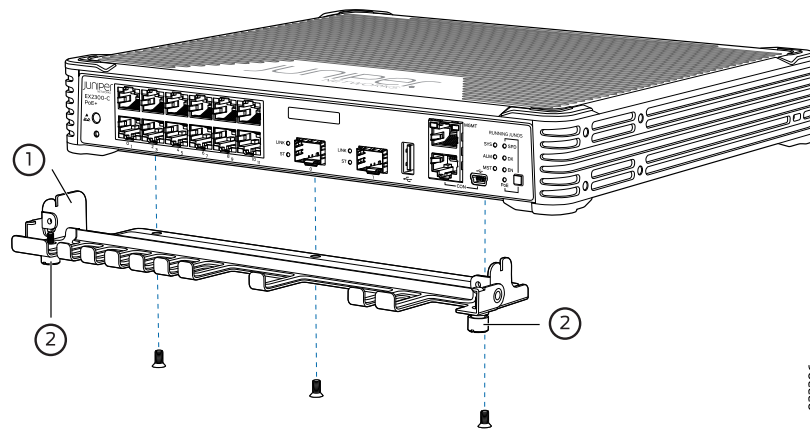

1— Cable guard

2— Thumb screws

- Attach the self adhesive rubber pads provided with the magnet-mount kit to the bottom of the switch as shown in [Figure 51 on page 128](#).

Figure 51: Attaching Rubber Pads to an EX2300-C Switch

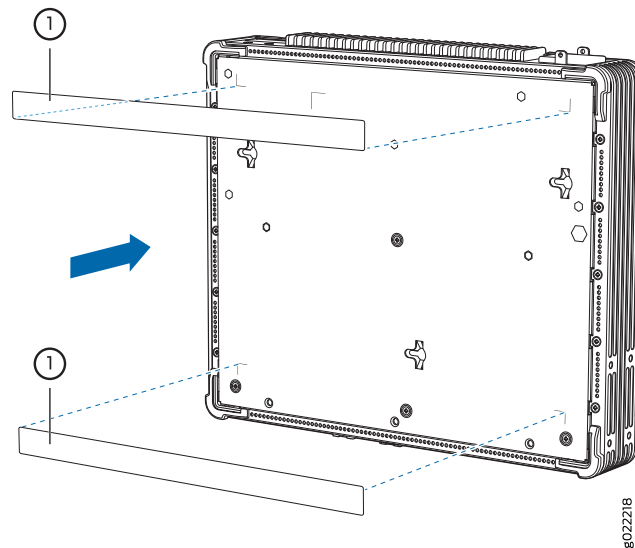

1— Self adhesive rubber pads

- Attach the surface of the magnet mount sheet that has the **Running Junos** logo to the rubber pads (see [Figure 52 on page 129](#)).

Figure 52: Attaching the Magnet Mount Sheet to an EX2300-C Switch

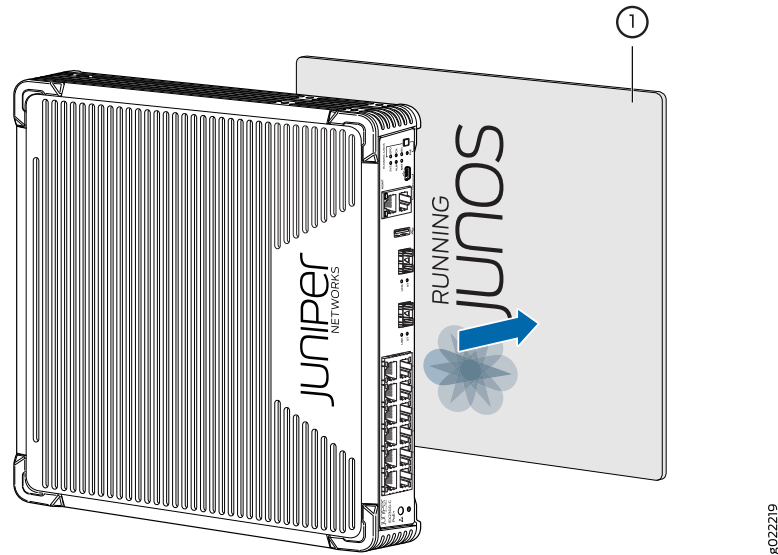

8022219

1—Magnet mount sheet

6. Mount the switch along with the magnet mount sheet on the ferrous surface on which you want to mount the switch (see [Figure 53 on page 130](#)).

Figure 53: Mounting an EX2300-C Switch on or Under a Surface Made of Ferrous Material

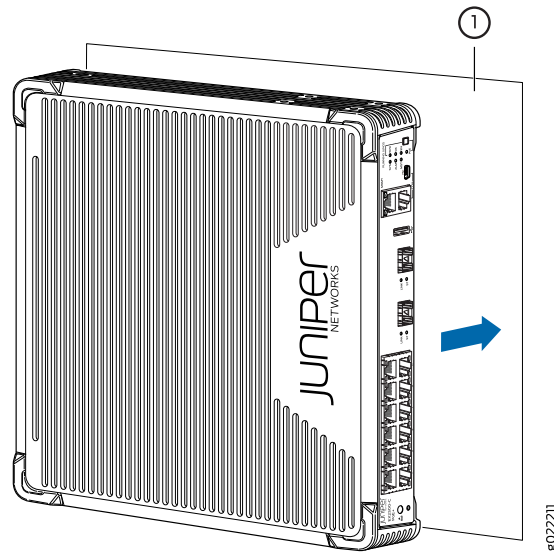

1— Ferrous surface

7. (Optional) Attach the standard cable lock to the security slot on the switch:
 - a. Fasten the cable to a desk or a rack and set the lock to unlocked position using the key.
 - b. Insert the lock into the security slot on your chassis and set the lock to the locked position using the key. See [Figure 54](#) on page 130.

Figure 54: Securing the EX2300-C Switch by Using the Security Slot

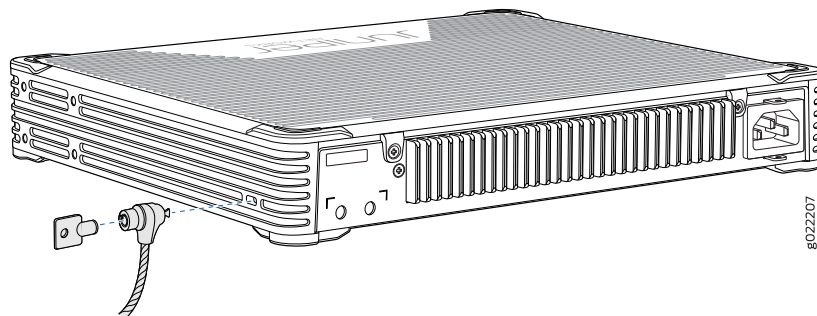

Related Documentation

- [Connecting AC Power to an EX2300 Switch](#) on page 140
- [Connecting and Configuring an EX Series Switch \(CLI Procedure\)](#) on page 159
- [Connecting and Configuring an EX Series Switch \(J-Web Procedure\)](#) on page 162

Mounting an EX2300 Switch in a Recessed Position in a Rack or Cabinet

You can mount an EX2300 switch except the EX2300-C switch model on two posts or four posts of a rack or cabinet such that the switch is recessed inside the rack from the rack front by 2 inches. You can use the 2-in.-recess front-mounting brackets provided in the separately orderable four-post rack-mount kit to mount the switch in a recessed position.

Reasons that you might want to mount the switch in a recessed position include:

- You are mounting the switch in a cabinet and the cabinet doors do not close completely unless the switch is recessed.
- The switch you are mounting has transceivers installed in the uplink ports—the transceivers in the uplink ports protrude from the front of the switch.

To mount the switch in a recessed position on four posts, follow the instructions in [“Mounting an EX2300 Switch on Four Posts of a Rack or Cabinet” on page 114](#). To mount the switch in a recessed position on two posts, follow the instructions in [“Mounting an EX2300 Switch on Two Posts of a Rack or Cabinet” on page 112](#).

Related Documentation

- [Connecting Earth Ground to an EX Series Switch on page 133](#)
- [Rack-Mounting and Cabinet-Mounting Warnings on page 224](#)

Connecting the Switch to Power

- [Connecting Earth Ground to an EX Series Switch on page 133](#)
- [Connecting AC Power to an EX2300 Switch on page 140](#)
- [Connecting DC Power to an EX2300 Switch on page 143](#)

Connecting Earth Ground to an EX Series Switch

To ensure proper operation and to meet safety and electromagnetic interference (EMI) requirements, you must connect an EX Series switch to earth ground before you connect power to the switch. You must use the protective earthing terminal on the switch chassis to connect the switch to earth ground (see [Figure 56 on page 139](#)).



WARNING: The switch is installed in a restricted-access location. It has a separate protective earthing terminal on the chassis that must be permanently connected to earth ground to adequately ground the chassis and protect the operator from electrical hazards.



CAUTION: Before switch installation begins, ensure that a licensed electrician has attached an appropriate grounding lug to the grounding cable that you supply. Using a grounding cable with an incorrectly attached lug can damage the switch.

This topic describes:

- [Parts and Tools Required for Connecting an EX Series Switch to Earth Ground on page 133](#)
- [Special Instructions to Follow Before Connecting Earth Ground to a Switch on page 137](#)
- [Connecting Earth Ground to an EX Series Switch on page 139](#)

Parts and Tools Required for Connecting an EX Series Switch to Earth Ground

[Table 52 on page 134](#) lists the earthing terminal location, grounding cable requirements, grounding lug specifications, screws and washers required, and the screwdriver needed

for connecting a switch to earth ground. Before you begin connecting a switch to earth ground, ensure you have the parts and tools required for your switch.

Table 52: Parts and Tools Required for Connecting an EX Series Switch to Earth Ground

Switch	Earthing Terminal Location	Grounding Cable Requirements	Grounding Lug Specifications	Screws and Washers	Screwdriver	Additional Information
EX2200	Rear panel of the chassis	14 AWG (2 mm ²), minimum 90 °C wire, or as permitted by the local code	Panduit LCC10-14BWL or equivalent— not provided	<ul style="list-style-type: none"> Two 10-32 x .25 in. screws with #10 split-lock washer— not provided Two #10 flat washers—not provided 	Phillips (+) number 2	
EX2300-C	Rear panel of the chassis	14 AWG (2 mm ²), minimum 90 °C wire, or as permitted by the local code	Panduit LCC10-14AW-L or equivalent— not provided	<ul style="list-style-type: none"> Two 10-32 x .25 in. screws with #10 split-lock washer— not provided Two #10 flat washers—not provided 	Phillips (+) number 2	
EX2300	Rear panel of the chassis	<ul style="list-style-type: none"> EX2300 switches except EX2300-24MP and EX2300-48MP models—14 AWG (2 mm²), minimum 90 °C wire, or as permitted by the local code EX2300-24MP and EX2300-48MP models—14-10 AWG STR (2.5-6 mm²), 12-10 AWG SOL (4-6 mm²) minimum 90 °C wire, or as permitted by the local code 	<ul style="list-style-type: none"> EX2300 switches except EX2300-24MP and EX2300-48MP models—Panduit LCC10-14AW-L or equivalent— not provided EX2300-24MP and EX2300-48MP models—Panduit LCA10-10L or equivalent— not provided 	<p>EX2300 switches except EX2300-24MP and EX2300-48MP models</p> <ul style="list-style-type: none"> Two 10-32 x .25 in. screws with #10 split-lock washer— not provided Two #10 flat washers—not provided <p>EX2300-24MP and EX2300-48MP models</p> <ul style="list-style-type: none"> One Pan Phillips M 4 x 6 mm Nickel plated screw— provided 	Phillips (+) number 2	
EX3200	Rear panel of the chassis	14 AWG (2 mm ²), minimum 90 °C wire, or as permitted by the local code	Panduit LCC10-14BWL or equivalent— not provided	<ul style="list-style-type: none"> Two 10-32 x .25 in. screws with #10 split-lock washer— not provided Two #10 flat washers— not provided 	Phillips (+) number 2	See “Special Instructions to Follow Before Connecting Earth Ground to a Switch” on page 137.

Table 52: Parts and Tools Required for Connecting an EX Series Switch to Earth Ground (*continued*)

Switch	Earthing Terminal Location	Grounding Cable Requirements	Grounding Lug Specifications	Screws and Washers	Screwdriver	Additional Information
EX3300	Rear panel of the chassis	14 AWG (2 mm ²), minimum 90 °C wire, or as permitted by the local code	Panduit LCC10-14BWL or equivalent— not provided	<ul style="list-style-type: none"> Two 10-32 x .25 in. screws with #10 split-lock washer— not provided Two #10 flat washers— not provided 	Phillips (+) number 2	
EX3400	Rear panel of the chassis	14 AWG (2 mm ²), minimum 90 °C wire, or as permitted by the local code	Panduit LCC10-14AW-L or equivalent— not provided	<ul style="list-style-type: none"> Two 10-32 x .25 in. screws with #10 split-lock washer— not provided Two #10 flat washers— not provided 	Phillips (+) number 2	
EX4200	Left side of the chassis	14 WG (2 mm ²), minimum 90 °C wire, or as permitted by the local code	Panduit LCC10-14BWL or equivalent— not provided	<ul style="list-style-type: none"> Two 10-32 x .25 in. screws with #10 split-lock washer— not provided Two #10 flat washers— not provided 	Phillips (+) number 2	See “Special Instructions to Follow Before Connecting Earth Ground to a Switch” on page 137.
EX4300	Left side of the chassis	14 AWG (2 mm ²), minimum 90 °C wire, or as permitted by the local code	Panduit LCC10-14BWL or equivalent— not provided	<ul style="list-style-type: none"> Two 10-32 x .25 in. screws with #10 split-lock washer— not provided Two #10 flat washers— not provided 	Phillips (+) number 2	See “Special Instructions to Follow Before Connecting Earth Ground to a Switch” on page 137.
EX4500	Left side of the chassis	14 AWG (2 mm ²), minimum 90 °C wire, or as permitted by the local code	Panduit LCC10-14BWL or equivalent— not provided	<ul style="list-style-type: none"> Two 10-32 x .25 in. screws with #10 split-lock washer— not provided Two #10 flat washers— not provided 	Phillips (+) number 2	See “Special Instructions to Follow Before Connecting Earth Ground to a Switch” on page 137.

Table 52: Parts and Tools Required for Connecting an EX Series Switch to Earth Ground (*continued*)

Switch	Earthing Terminal Location	Grounding Cable Requirements	Grounding Lug Specifications	Screws and Washers	Screwdriver	Additional Information
EX4550	Left side of the chassis	14 AWG (2 mm ²), minimum 90 °C wire, or as permitted by the local code	Panduit LCC10-14BWL or equivalent— not provided	<ul style="list-style-type: none"> Two 10-32 x .25 in. screws with #10 split-lock washer— not provided Two #10 flat washers— not provided 	Phillips (+) number 2	See “Special Instructions to Follow Before Connecting Earth Ground to a Switch” on page 137.
EX6210	Rear panel of the chassis (on lower left side)	The grounding cable must be the same gage as the power feed cables and as permitted by the local code.	Panduit LCD2-14A-Q or equivalent— provided	<ul style="list-style-type: none"> Two ¼-20 x 0.5 in. screws with #¼” split-washer— provided Two #¼” flat washers— provided 	Phillips (+) number 2	
EX8208	Left side of the chassis	6 AWG (13.3 mm ²), minimum 60 °C wire, or as permitted by the local code	Panduit LCD2-14A-Q or equivalent— provided	<ul style="list-style-type: none"> Two ¼-20 x 0.5 in. screws with #¼” split-washer— provided Two #¼” flat washers— provided 	Phillips (+) number 2	
EX8216	Two earthing terminals: <ul style="list-style-type: none"> Left side of the chassis Rear panel of the chassis 	2 AWG (33.6 mm ²), minimum 60 °C wire, or as permitted by the local code	Panduit LCD2-14A-Q or equivalent— provided	<ul style="list-style-type: none"> Two ¼-20 x 0.5 in. screws with #¼” split-washer— provided Two #¼” flat washers— provided 	Phillips (+) number 2	See “Special Instructions to Follow Before Connecting Earth Ground to a Switch” on page 137.
EX9204	Rear panel of the chassis	One 6 AWG (13.3 mm ²), minimum 60 °C wire, or one that complies with the local code	Thomas&Betts LCN6-14 or equivalent— provided	<ul style="list-style-type: none"> Two ¼-20 x 0.5 in. screws with #¼” split-washer— provided Two #¼” flat washers— provided 	Phillips (+) number 2	See <i>Grounding Cable and Lug Specifications for EX9200 Switches</i> .

Table 52: Parts and Tools Required for Connecting an EX Series Switch to Earth Ground (continued)

Switch	Earthing Terminal Location	Grounding Cable Requirements	Grounding Lug Specifications	Screws and Washers	Screwdriver	Additional Information
EX9208	Rear panel of the chassis	One 6 AWG (13.3 mm ²), minimum 60 °C wire, or one that complies with the local code	Thomas&Betts LCN6-14 or equivalent—provided	<ul style="list-style-type: none"> Two ¼-20 x 0.5 in. screws with #¼" split-washer—provided Two #¼" flat washers—provided 	Phillips (+) number 2	See <i>Grounding Cable and Lug Specifications for EX9200 Switches</i> .
EX9214	Rear panel of the chassis	One 6 AWG (13.3 mm ²), minimum 60 °C wire, or one that complies with the local code	Thomas&Betts LCN6-14 or equivalent—provided	<ul style="list-style-type: none"> Two ¼-20 x 0.5 in. screws with #¼" split-washer—provided Two #¼" flat washers—provided 	Phillips (+) number 2	See <i>Grounding Cable and Lug Specifications for EX9200 Switches</i> .
EX9251	Rear panel of the chassis	14–10 AWG (2–5.3 mm ²), minimum 60 °C wire, or one that complies with the local code	Panduit LCD10-10A-L or equivalent—not provided	Two M4 hex screws—provided	Phillips (+) number 2	<i>Grounding Cable and Lug Specifications for EX9251 Switch</i>

Special Instructions to Follow Before Connecting Earth Ground to a Switch

Table 53 on page 137 lists the special instructions that you might need to follow before connecting earth ground to a switch.

Table 53: Special Instructions to Follow Before Connecting Earth Ground to a Switch

Switch	Special Instructions
EX3200	NOTE: Some early variants of EX3200 switches for which the Juniper Networks model number on the label next to the protective earthing terminal is from 750-021xxx through 750-030xxx require 10-24x.25 in. screws.

Table 53: Special Instructions to Follow Before Connecting Earth Ground to a Switch (*continued*)

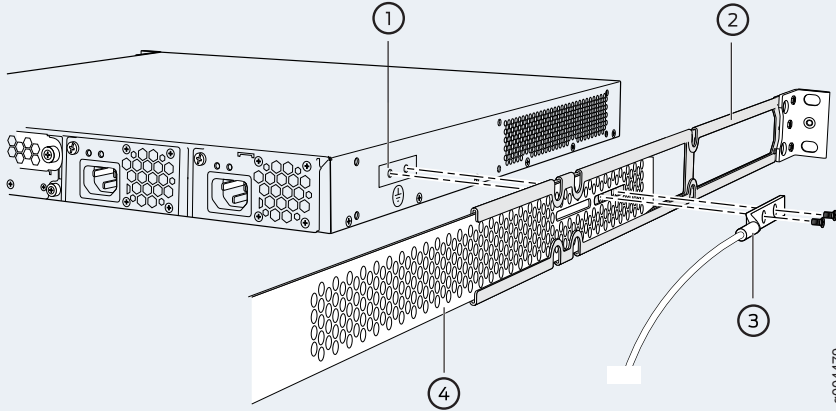
Switch	Special Instructions				
EX4200	<p>NOTE: Some early variants of EX4200 switches for which the Juniper Networks model number on the label next to the protective earthing terminal is from 750-021xxx through 750-030xxx require 10-24x.25 in. screws.</p> <p>NOTE: The protective earthing terminal on an EX4200 switch mounted on four posts of a rack is accessible through the slot on the left rear bracket only if the rack is 27.5 in. (69.85 cm) through 30.5 in. (77.47 cm) deep for a switch mounted flush with the rack front and 29.5 in. (74.93 cm) through 32.5 in. (82.55 cm) deep for a switch mounted 2 in. (5.08 cm) recessed from the rack front. See Figure 55 on page 138.</p> <p>Figure 55: Connecting the Grounding Lug to a Switch Mounted on Four Posts of a Rack</p>  <table border="1" data-bbox="683 1108 1419 1192"> <tbody> <tr> <td>1— Protective earthing terminal</td> <td>3—Grounding lug</td> </tr> <tr> <td>2—Side mounting-rail</td> <td>4—Rear mounting-blade</td> </tr> </tbody> </table> <p>NOTE: The brackets must be attached to the chassis before the grounding lug is attached. (The brackets are shown pulled away from the chassis so that the protective earthing terminal is seen.)</p>	1— Protective earthing terminal	3—Grounding lug	2—Side mounting-rail	4—Rear mounting-blade
1— Protective earthing terminal	3—Grounding lug				
2—Side mounting-rail	4—Rear mounting-blade				
EX4300	<p>NOTE: The protective earthing terminal on an EX4300 switch mounted on four posts of a rack is accessible through the slot on the left rear bracket only if the rack is 27.5 in. (69.85 cm) through 30.5 in. (77.47 cm) deep for a switch mounted flush with the rack front and 29.5 in. (74.93 cm) through 32.5 in. (82.55 cm) deep for a switch mounted 2 in. (5.08 cm) recessed from the rack front.</p>				
EX4500	<p>NOTE: If you plan to mount your switch on four posts of a rack or cabinet, mount your switch in the rack or cabinet before attaching the grounding lug to the switch. See <i>Mounting an EX4500 Switch on Four Posts in a Rack or Cabinet</i>.</p> <p>NOTE: The protective earthing terminal on an EX4500 switch mounted on four posts of a rack is accessible through the slot on the left rear bracket only if the rack is 27.5 in. (69.85 cm) through 30.5 in. (77.47 cm) deep for a switch mounted flush with the rack front and 29.5 in. (74.93 cm) through 32.5 in. (82.55 cm) deep for a switch mounted 2 in. (5.08 cm) recessed from the rack front.</p>				
EX4550	<p>NOTE: The protective earthing terminal on an EX4550 switch mounted on four posts of a rack is accessible through the slot on the left rear bracket only if the rack is 27.5 in. (69.85 cm) through 30.5 in. (77.47 cm) deep for a switch mounted flush with the rack front and 29.5 in. (74.93 cm) through 32.5 in. (82.55 cm) deep for a switch mounted 2 in. (5.08 cm) recessed from the rack front.</p>				
EX8216	<p>NOTE: Only one of the two protective earthing terminals needs to be permanently connected to earth ground.</p>				

Connecting Earth Ground to an EX Series Switch

To connect earth ground to a switch:

1. Connect one end of the grounding cable to a proper earth ground, such as the rack in which the switch is mounted.
2. Place the grounding lug attached to the grounding cable over the protective earthing terminal. See [Figure 56 on page 139](#).

Figure 56: Connecting a Grounding Cable to an EX Series Switch

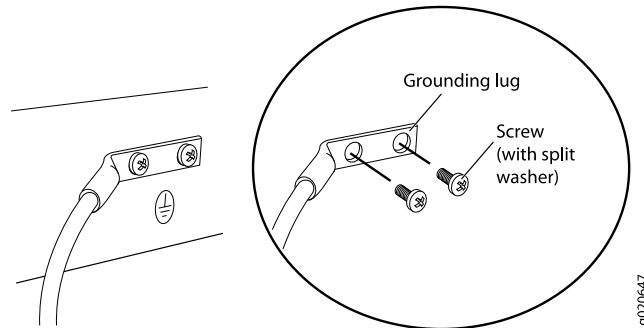

3. Secure the grounding lug to the protective earthing terminal with the washers and screws.
4. Dress the grounding cable and ensure that it does not touch or block access to other switch components.



WARNING: Ensure that the cable does not drape where people could trip over it.

Related Documentation

- [Connecting AC Power to an EX2200 Switch](#)
- [Connecting DC Power to an EX2200 Switch](#)
- [Connecting AC Power to an EX2300 Switch on page 140](#)
- [Connecting AC Power to an EX3200 Switch](#)
- [Connecting DC Power to an EX3200 Switch](#)
- [Connecting AC Power to an EX3300 Switch](#)
- [Connecting DC Power to an EX3300 Switch](#)
- [Connecting AC Power to an EX3400 Switch](#)
- [Connecting AC Power to an EX4200 Switch](#)
- [Connecting DC Power to an EX4200 Switch](#)

- *Connecting AC Power to an EX4300 Switch*
- *Connecting DC Power to an EX4300 Switch*
- *Connecting AC Power to an EX4500 Switch*
- *Connecting DC Power to an EX4500 Switch*
- *Connecting AC Power to an EX4550 Switch*
- *Connecting DC Power to an EX4550 Switch*
- *Connecting AC Power to an EX6200 Switch*
- *Connecting DC Power to an EX6200 Switch*
- *Connecting AC Power to an EX8200 Switch*
- *Connecting DC Power to an EX8200 Switch*
- *Connecting AC Power to an EX9204 Switch*
- *Connecting DC Power to an EX9204 Switch*
- *Connecting AC Power to an EX9208 Switch*
- *Connecting DC Power to an EX9208 Switch*
- *Connecting AC Power to an EX9214 Switch*
- *Connecting DC Power to an EX9214 Switch*
- [General Safety Guidelines and Warnings on page 213](#)
- [Grounded Equipment Warning on page 228](#)

Connecting AC Power to an EX2300 Switch

The power supply in an EX2300 switch is installed on the rear panel.

Ensure that you have the following parts and tools available:

- A power cord appropriate for your geographical location
- A power cord retainer clip (except for the EX2300-24MP model and the EX2300-48MP model)

Ensure that you have connected earth ground to the switch chassis.



CAUTION: To meet safety and electromagnetic interference (EMI) requirements and to ensure proper operation, you must connect the switches to earth ground before you connect them to power. For installations that require a separate grounding conductor to the chassis, use the protective earthing terminal on the switch chassis to connect to the earth ground. For instructions on connecting earth ground, see [“Connecting Earth Ground to an EX Series Switch” on page 133](#). An EX2300 switch gets additional grounding when you plug the power supply in the switch into a grounded AC power

outlet by using the AC power cord appropriate for your geographical location (see [“AC Power Cord Specifications for EX2300 Switches” on page 70](#)).

To connect AC power to the switch:

1. (This step is applicable to EX2300 switches except the EX2300-24MP model and the EX2300-48MP model) Squeeze the two sides of the power cord retainer clip and insert the L-shaped ends of the wire clip into the holes in the bracket above and below the AC power cord inlet on the rear panel (see [Figure 57 on page 142](#) and [Figure 58 on page 142](#)).

The power cord retainer clip in EX2300 switches except the EX2300-24MP model and the EX2300-48MP model extends out of the chassis by 3 in. (7.62 cm).

2. Locate the power cord or cords shipped with the switch; the cords have plugs appropriate for your geographical location. See [“AC Power Cord Specifications for EX2300 Switches” on page 70](#).



WARNING: Ensure that the power cord does not drape where people can trip on it or block access to switch components.

3. Insert the coupler end of the power cord into the AC power cord inlet on the rear panel.
4. (This step is applicable to EX2300 switches except the EX2300-24MP model and the EX2300-48MP model) Push the power cord into the slot in the adjustment nut of the power cord retainer clip. Turn the nut until it is tight against the base of the coupler and the slot in the nut is turned 90° from the top of the switch (see [Figure 59 on page 142](#) and [Figure 60 on page 142](#)).
5. If the AC power source outlet has a power switch, set it to the off (O) position.
6. Insert the power cord plug into an AC power source outlet.
7. If the AC power source outlet has a power switch, set it to the on (I) position.

Figure 57: Connecting an AC Power Cord Retainer Clip to the AC Power Cord Inlet on EX2300-C Switches

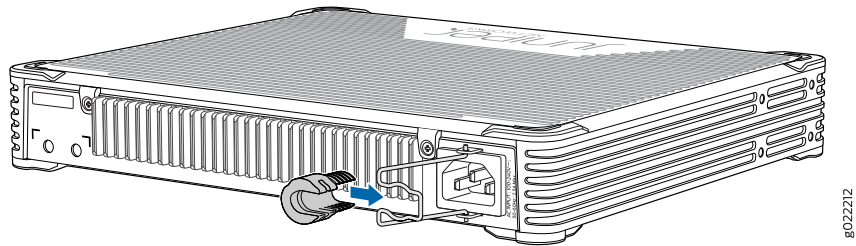

Figure 58: Connecting an AC Power Cord Retainer Clip to the AC Power Cord Inlet on EX2300 Switches Except the EX2300-C, EX2300-24MP, and EX2300-48MP Models

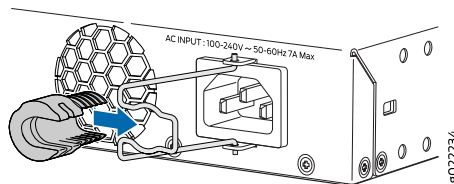

Figure 59: Connecting an AC Power Cord to the AC Power Cord Inlet on EX2300-C Switches

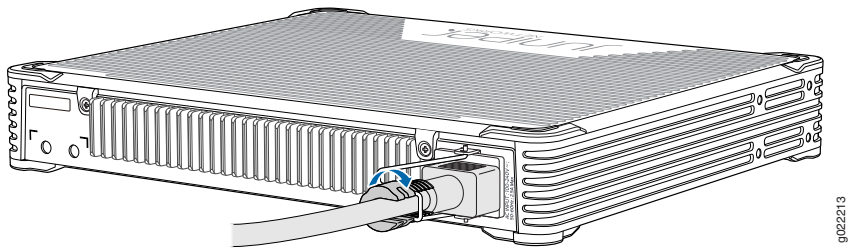
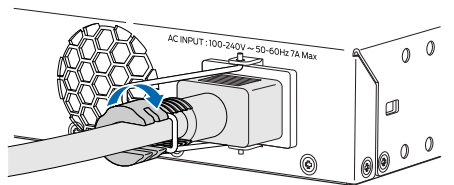

Figure 60: Connecting an AC Power Cord to the AC Power Cord Inlet on EX2300 Switches Except EX2300-C Switches



Related Documentation

- [Connecting and Configuring an EX Series Switch \(CLI Procedure\)](#) on page 159
- [Connecting and Configuring an EX Series Switch \(J-Web Procedure\)](#) on page 162
- [Power Supply in EX2300 Switches](#) on page 29

Connecting DC Power to an EX2300 Switch

The power supply is built-in along the rear panel.



WARNING: DC-powered switches are intended for installation only in a restricted-access location.

Before you begin connecting DC power to the switch, ensure that you have connected earth ground to the switch chassis.



CAUTION: Before you connect power to the switch, a licensed electrician must attach a cable lug to the grounding and power cables. A cable with an incorrectly attached lug can damage the switch (for example, by causing a short circuit).

To meet safety and electromagnetic interference (EMI) requirements and to ensure proper operation, you must connect the switch to earth ground before you connect them to power. For installations that require a separate grounding conductor to the chassis, use the protective earthing terminal on the switch chassis to connect to the earth ground. For instructions on connecting earth ground, see [“Connecting Earth Ground to an EX Series Switch” on page 133](#).



NOTE: Grounding is required for DC systems and recommended for AC systems.

Ensure that you have taken the necessary precautions to prevent electrostatic discharge (ESD) damage (see [“Prevention of Electrostatic Discharge Damage” on page 243](#)).

Ensure that you have the following parts and tools available:

- DC power source cables (14 AWG) with ring lug (Molex 0190700067 or equivalent) (not provided) attached to them by a licensed electrician
- Phillips (+) screwdriver, number 2

To connect DC power to the switch:

1. Ensure that the input circuit breaker is open so that the cable leads do not become active while you are connecting DC power.



NOTE: The DC power supply in the switch has four terminals labeled **INPUT 1+**, **INPUT 1-**, **INPUT 2+**, and **INPUT 2-** for connecting DC power source cables labeled positive (+) and negative (-). The terminals are covered by a clear plastic cover.



NOTE: The **INPUT 1+** and **INPUT 2+** terminals are referred to as **+RTN** and **INPUT 1-** and **INPUT 2-** terminals are referred to as **-48 V** in “[DC Power Wiring Sequence Warning](#)” on page 251 and “[DC Power Electrical Safety Guidelines for Switches](#)” on page 246.

2. Grasp the plastic cover in the middle, gently bend it outward, and pull it out. Save the cover.
3. Remove the screws on the terminals by using the screwdriver. Save the screws.



WARNING: Ensure that the power cables do not block access to switch components or drape where people can trip on them.

4. Connect the power supply to the power sources. Secure power source cables to the power supply by screwing the ring lugs attached to the cables to the appropriate terminals by using the screw from the terminals (see [Figure 61 on page 144](#)).

Figure 61: Securing the Ring Lugs On the Power Cables to the Terminals on the DC Power Supply

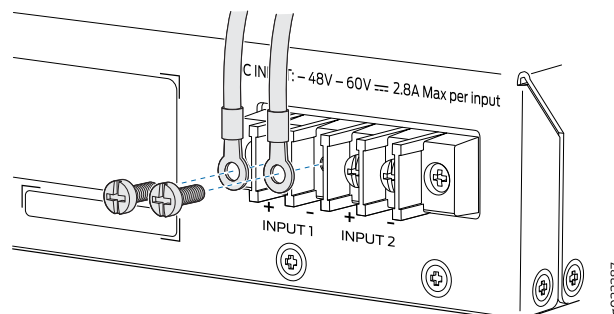

- To connect the power supply to one power source:
 - a. Secure the ring lug of the positive (+) DC power source cable to the **INPUT 1+** or **INPUT 2+** terminal on the DC power supply.

- b. Secure the ring lug of the negative (–) DC power source cable to the **INPUT 1–** or **INPUT 2–** terminal on the DC power supply.
 - c. Tighten the screws on the power supply terminals until snug by using the screwdriver. Do not overtighten—apply between 8 lb-in. (0.9 Nm) and 9 lb-in. (1.02 Nm) of torque to the screws.
- To connect the power supply to two power sources:
 - a. Secure the ring lug of the positive (+) DC power source cable from the first DC power source to the **INPUT 1+** terminal on the power supply.
 - b. Secure the ring lug of the negative (–) DC power source cable from the first DC power source to the **INPUT 1–** terminal on the power supply.
 - c. Secure the ring lug of the positive (+) DC power source cable from the second DC power source to the **INPUT 2+** terminal on the power supply.
 - d. Secure the ring lug of the negative (–) DC power source cable from the second DC power source to the **INPUT 2–** terminal on the power supply.
 - e. Tighten the screws on the power supply terminals on both the power supplies until snug by using the screwdriver. Do not overtighten—apply between 8 lb-in. (0.9 Nm) and 9 lb-in. (1.02 Nm) of torque to the screws.
5. Hook the plastic cover on one side of the terminal block and gently bend it inward to hook it on the other side also.
 6. Close the input circuit breaker.

**Related
Documentation**

- [Connecting and Configuring an EX Series Switch \(CLI Procedure\) on page 159](#)
- [Power Supply in EX2300 Switches on page 29](#)

Connecting the Switch to the Network

- [Connecting a Device to a Network for Out-of-Band Management on page 147](#)
- [Connecting a Device to a Management Console by Using an RJ-45 Connector on page 148](#)
- [Connecting an EX Series Switch to a Management Console by Using the Mini-USB Type-B Console Port on page 149](#)
- [Connecting a Fiber-Optic Cable on page 151](#)

Connecting a Device to a Network for Out-of-Band Management

You can monitor and manage these devices by using a dedicated management channel. Each device has a management port to which you can connect an Ethernet cable with an RJ-45 connector. Use the management port to connect the device to the management device.

Ensure that you have an Ethernet cable that has an RJ-45 connector at either end. [Figure 62 on page 147](#) shows the RJ-45 connector of the Ethernet cable supplied with the device.

Figure 62: RJ-45 Connector on an Ethernet Cable

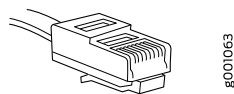

To connect a device to a network for out-of-band management (see [Figure 63 on page 148](#)):

1. Connect one end of the Ethernet cable to the management port (labeled **MGMT** or **ETHERNET**) on the device.
2. Connect the other end of the Ethernet cable to the management device.

Figure 63: Connecting a Device to a Network for Out-of-Band Management

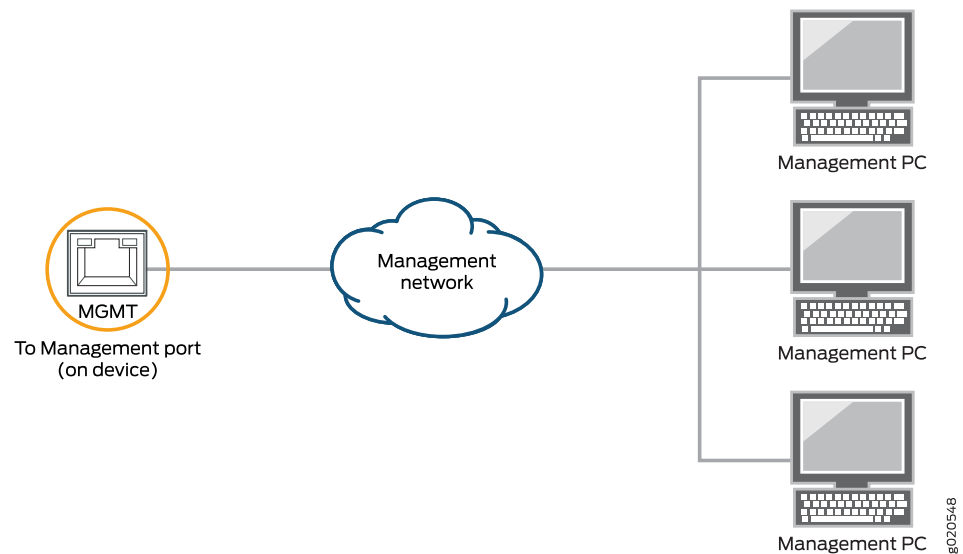

- Related Documentation**
- [Connecting a Device to a Management Console by Using an RJ-45 Connector on page 148](#)

Connecting a Device to a Management Console by Using an RJ-45 Connector

You can configure and manage these devices by using a dedicated management channel. Each device has a console port to which you can connect an Ethernet cable with an RJ-45 connector. Use the console port to connect the device to the console server or management console. The console port accepts a cable that has an RJ-45 connector.

Ensure that you have an Ethernet cable that has an RJ-45 connector at either end. One such cable and an RJ-45 to DB-9 serial port adapter are supplied with the device.

[Figure 64 on page 148](#) shows the RJ-45 connector of the Ethernet cable.

Figure 64: RJ-45 Connector on an Ethernet Cable

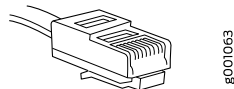

NOTE: If your laptop or PC does not have a DB-9 male connector pin and you want to connect your laptop or PC directly to the device, use a combination of the RJ-45 to DB-9 female adapter supplied with the device and a USB to DB-9 male adapter. You must provide the USB to DB-9 male adapter.

To connect the device to a management console (see [Figure 65 on page 149](#) and [Figure 66 on page 149](#)):

1. Connect one end of the Ethernet cable to the console port (labeled **CON**, **CONSOLE**, or **CON1**) on the device.
2. Connect the other end of the Ethernet cable to the console server (see [Figure 65 on page 149](#)) or management console (see [Figure 66 on page 149](#)).

Figure 65: Connecting a Device to a Management Console Through a Console Server

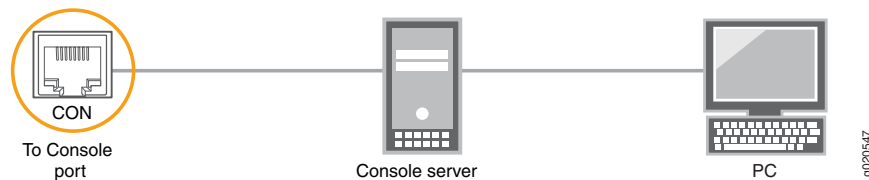

Figure 66: Connecting a Device Directly to a Management Console



Related Documentation

- [Connecting a Device to a Network for Out-of-Band Management on page 147](#)

Connecting an EX Series Switch to a Management Console by Using the Mini-USB Type-B Console Port

You can configure and manage EX2200-C, EX2300, EX3400, EX4300, and EX4550 switches by using the RJ-45 console port or the Mini-USB Type-B console port. However, on EX2200-C and EX4550 switches, only one console port is active at a time and the console input is active only on that port. On EX2300, EX3400, and EX4300 switches, both the RJ-45 console port and the Mini-USB Type-B console port are active at the same time.

If your laptop or PC does not have a DB-9 male connector pin or RJ-45 connector pin, you can connect your laptop or PC directly to the switch by using a mini-USB cable that has a Standard-A USB connector on one end and a Mini-USB Type-B (5-pin) connector on the other end.

This topic describes the procedure to connect an EX2200-C, EX2300, EX3400, EX4300, and EX4550 switch to the management console by using the Mini-USB Type-B console port.

For information about configuring and managing an EX Series switch by using the RJ-45 console port, see [“Connecting a Device to a Management Console by Using an RJ-45 Connector” on page 148](#).

Before you begin connecting the switch by using the Mini-USB Type-B console port:

- Ensure that the USB to Serial driver is installed on the host machine. You can download the driver from <https://webdownload.juniper.net/swdl/dl/secure/site/1/record/5029.html>.
- Ensure that the HyperTerminal properties of the console server or laptop are set as follows:
 - Baud rate—9600
 - Flow control—None
 - Data—8
 - Parity—None
 - Stop bits—1
 - DCD state—Disregard

Ensure that you have the following parts and tools available:

- One mini-USB cable with Standard-A and Mini-USB Type-B (5-pin) connectors (not provided).

To connect the switch to the console by using the Mini-USB Type-B console port:

1. Connect the Standard-A connector of the mini-USB cable to the host machine (PC or laptop).
2. Connect the Mini-USB Type-B (5-pin) connector of the mini-USB cable to the Mini-USB Type-B console port (labeled **CON**) on the switch.
3. Set the Mini-USB Type-B console port as the active console port by using the **port-type** command.

By default, the RJ-45 port is set as an active console port and the Mini-USB Type-B port is the passive console port. For information about configuring the console port type, see *Configuring the Console Port Type (CLI Procedure)*.

4. Reboot the switch.

After the connection is established, the Mini-USB Type-B becomes the active console port. The host machine connected to the Mini-USB Type-B console port displays log messages and enables you to control switch functionality through it.

Related Documentation

- [Connecting a Device to a Network for Out-of-Band Management on page 147](#)
- [Console Port Connector Pinout Information on page 85](#)

- Management Cable Specifications on page 82

Connecting a Fiber-Optic Cable

Before you begin connecting a fiber-optic cable to an optical transceiver installed in a device, ensure that you have taken the necessary precautions for safe handling of lasers (see “Laser and LED Safety Guidelines and Warnings” on page 231).

To connect a fiber-optic cable to an optical transceiver installed in a device:



WARNING: Do not look directly into a fiber-optic transceiver or into the ends of fiber-optic cables. Fiber-optic transceivers and fiber-optic cables connected to transceivers emit laser light that can damage your eyes.

1. If the fiber-optic cable connector is covered with a rubber safety cap, remove the cap. Save the cap.
2. Remove the rubber safety cap from the optical transceiver. Save the cap.
3. Insert the cable connector into the optical transceiver (see Figure 67 on page 151).

Figure 67: Connecting a Fiber-Optic Cable to an Optical Transceiver Installed in a Device

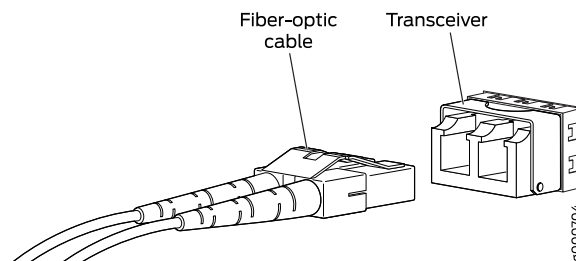

4. Secure the cables so that they do not support their own weight. Place excess cable out of the way in a neatly coiled loop. Placing fasteners on a loop helps cables maintain their shape.



CAUTION: Do not bend fiber-optic cables beyond their minimum bend radius. An arc smaller than a few inches in diameter can damage the cables and cause problems that are difficult to diagnose.

Do not let fiber-optic cables hang free from the connector. Do not allow fastened loops of cables to dangle, which stresses the cables at the fastening point.

**Related
Documentation**

- [Disconnecting a Fiber-Optic Cable from a Device on page 182](#)
- [Installing a Transceiver on page 175](#)
- [Maintaining Fiber-Optic Cables on page 183](#)

Performing Initial Configuration

- [EX2300 Switch Default Configuration on page 153](#)
- [Connecting and Configuring an EX Series Switch \(CLI Procedure\) on page 159](#)
- [Connecting and Configuring an EX Series Switch \(J-Web Procedure\) on page 162](#)
- [Reverting to the Default Factory Configuration for the EX Series Switch on page 167](#)

EX2300 Switch Default Configuration

Each EX Series switch is programmed with a factory-default configuration that contains the values set for each configuration parameter when a switch is shipped. The default configuration file for an EX2300 switch configures Ethernet switching and storm control on all interfaces, configures Power over Ethernet (PoE) on all interfaces of models that provide PoE, and enables the LLDP, LLDP-MED, and RSTP protocols and IGMP snooping.

When you commit changes to the configuration, a new configuration file is created that becomes the active configuration. You can always revert to the factory-default configuration—EX2300 switches do not have LCD panel, use the CLI commands to revert to the factory-default configuration. See [“Reverting to the Default Factory Configuration for the EX Series Switch” on page 167](#).

The following factory-default configuration file is for an EX2300 switch with 24 ports with PoE capability.



NOTE: The factory-default configuration file is different for different EX2300 switch models.

The number of interfaces in the default configuration file depends on the number of ports in the EX2300 switch.

The `poe` statement does not appear for models without PoE.

Uplink ports on EX2300 switches except EX2300-C switches are listed as `ge-0/1/0` to `ge-0/1/3` and `xe-0/1/0` to `xe-0/1/3`. Uplink ports on EX2300-C switches as `ge-0/1/0` to `ge-0/1/1` and `xe-0/1/0` to `xe-0/1/1`.

```
system {  
  auto-snapshot;
```

```
syslog {
  user * {
    any emergency;
  }
  file messages {
    any notice;
    authorization info;
  }
  file interactive-commands {
    interactive-commands any;
  }
}
commit {
  factory-settings {
    reset-virtual-chassis-configuration;
    reset-chassis-lcd-menu;
  }
}
}
interfaces {
  ge-0/0/0 {
    unit 0 {
      family ethernet-switching {
        storm-control default;
      }
    }
  }
  ge-0/0/1 {
    unit 0 {
      family ethernet-switching {
        storm-control default;
      }
    }
  }
  ge-0/0/2 {
    unit 0 {
      family ethernet-switching {
        storm-control default;
      }
    }
  }
  ge-0/0/3 {
    unit 0 {
      family ethernet-switching {
        storm-control default;
      }
    }
  }
  ge-0/0/4 {
    unit 0 {
      family ethernet-switching {
        storm-control default;
      }
    }
  }
  ge-0/0/5 {
```



```
    unit 0 {
      family ethernet-switching {
        storm-control default;
      }
    }
  }
  ge-0/0/6 {
    unit 0 {
      family ethernet-switching {
        storm-control default;
      }
    }
  }
  ge-0/0/7 {
    unit 0 {
      family ethernet-switching {
        storm-control default;
      }
    }
  }
  ge-0/0/8 {
    unit 0 {
      family ethernet-switching {
        storm-control default;
      }
    }
  }
  ge-0/0/9 {
    unit 0 {
      family ethernet-switching {
        storm-control default;
      }
    }
  }
  ge-0/0/10 {
    unit 0 {
      family ethernet-switching {
        storm-control default;
      }
    }
  }
  ge-0/0/11 {
    unit 0 {
      family ethernet-switching {
        storm-control default;
      }
    }
  }
  ge-0/0/12 {
    unit 0 {
      family ethernet-switching {
        storm-control default;
      }
    }
  }
  ge-0/0/13 {
```

```
    unit 0 {
      family ethernet-switching {
        storm-control default;
      }
    }
  }
  ge-0/0/14 {
    unit 0 {
      family ethernet-switching {
        storm-control default;
      }
    }
  }
  ge-0/0/15 {
    unit 0 {
      family ethernet-switching {
        storm-control default;
      }
    }
  }
  ge-0/0/16 {
    unit 0 {
      family ethernet-switching {
        storm-control default;
      }
    }
  }
  ge-0/0/17 {
    unit 0 {
      family ethernet-switching {
        storm-control default;
      }
    }
  }
  ge-0/0/18 {
    unit 0 {
      family ethernet-switching {
        storm-control default;
      }
    }
  }
  ge-0/0/19 {
    unit 0 {
      family ethernet-switching {
        storm-control default;
      }
    }
  }
  ge-0/0/20 {
    unit 0 {
      family ethernet-switching {
        storm-control default;
      }
    }
  }
  ge-0/0/21 {
```

```
    unit 0 {
      family ethernet-switching {
        storm-control default;
      }
    }
  }
  ge-0/0/22 {
    unit 0 {
      family ethernet-switching {
        storm-control default;
      }
    }
  }
  ge-0/0/23 {
    unit 0 {
      family ethernet-switching {
        storm-control default;
      }
    }
  }
  ge-0/1/0 {
    unit 0 {
      family ethernet-switching {
        storm-control default;
      }
    }
  }
  xe-0/1/0 {
    unit 0 {
      family ethernet-switching {
        storm-control default;
      }
    }
  }
  ge-0/1/1 {
    unit 0 {
      family ethernet-switching {
        storm-control default;
      }
    }
  }
  xe-0/1/1 {
    unit 0 {
      family ethernet-switching {
        storm-control default;
      }
    }
  }
  ge-0/1/2 {
    unit 0 {
      family ethernet-switching {
        storm-control default;
      }
    }
  }
  xe-0/1/2 {
```

```
    unit 0 {
      family ethernet-switching {
        storm-control default;
      }
    }
  }
  ge-0/1/3 {
    unit 0 {
      family ethernet-switching {
        storm-control default;
      }
    }
  }
  xe-0/1/3 {
    unit 0 {
      family ethernet-switching {
        storm-control default;
      }
    }
  }
}
forwarding-options {
  storm-control-profiles default {
    all;
  }
}
protocols {
  lldp {
    interface all;
  }
  lldp-med {
    interface all;
  }
  igmp-snooping {
    vlan default;
  }
  rstp {
    interface ge-0/0/0;
    interface ge-0/0/1;
    interface ge-0/0/2;
    interface ge-0/0/3;
    interface ge-0/0/4;
    interface ge-0/0/5;
    interface ge-0/0/6;
    interface ge-0/0/7;
    interface ge-0/0/8;
    interface ge-0/0/9;
    interface ge-0/0/10;
    interface ge-0/0/11;
    interface ge-0/0/12;
    interface ge-0/0/13;
    interface ge-0/0/14;
    interface ge-0/0/15;
    interface ge-0/0/16;
    interface ge-0/0/17;
    interface ge-0/0/18;
```

```

interface ge-0/0/19;
interface ge-0/0/20;
interface ge-0/0/21;
interface ge-0/0/22;
interface ge-0/0/23;
interface ge-0/1/0;
interface xe-0/1/0;
interface ge-0/1/1;
interface xe-0/1/1;
interface ge-0/1/2;
interface xe-0/1/2;
interface ge-0/1/3;
interface xe-0/1/3;
}
}
poe {
  interface all;
}

```

Related Documentation

- [Configuration Files Terms](#)
- [Connecting and Configuring an EX Series Switch \(CLI Procedure\) on page 159](#)
- [Connecting and Configuring an EX Series Switch \(J-Web Procedure\) on page 162](#)
- [Understanding Configuration Files for EX Series Switches](#)
- [EX2300 Switches Hardware Overview on page 3](#)

Connecting and Configuring an EX Series Switch (CLI Procedure)

There are two ways to connect and configure an EX Series switch: one method is through the console by using the CLI and the other is by using the J-Web interface.



NOTE: EX2200-24T-4G-DC switches do not support switch connection and configuration through the J-Web interface.

This topic describes the CLI procedure.



NOTE: To run the `ezsetup` script, the switch must have the factory-default configuration as the active configuration. If you have configured anything on the switch and want to run `ezsetup`, revert to the factory-default configuration. See [“Reverting to the Default Factory Configuration for the EX Series Switch” on page 167](#).

Using the CLI, set the following parameter values in the console server or PC:

- Baud rate—9600
- Flow control—None

- Data—8
- Parity—None
- Stop bits—1
- DCD state—Disregard

To connect and configure the switch from the console by using the CLI:

1. Connect the console port to a laptop or PC by using the RJ-45 to DB-9 serial port adapter. An Ethernet cable that has an RJ-45 connector at either end and an RJ-45 to DB-9 serial port adapter are supplied with the switch.

For the location of the console port on different EX Series switches:

- See *EX2200 Switches Hardware Overview*.
- See [“EX2300 Switches Hardware Overview” on page 3](#).
- See *Rear Panel of an EX3200 Switch*.
- See *Rear Panel of an EX3300 Switch*.
- See *Rear Panel of an EX3400 Switch*.
- See *Rear Panel of an EX4200 Switch*.
- See *EX4300 Switches Hardware Overview*
- See *Front Panel of an EX4500 Switch*.
- See *EX4550 Switches Hardware Overview*
- See *Switch Fabric and Routing Engine (SRE) Module in an EX6200 Switch*.
- See *Switch Fabric and Routing Engine (SRE) Module in an EX8208 Switch*.
- See *Routing Engine (RE) Module in an EX8216 Switch*.



NOTE: In EX2200-C, EX2300, EX3400, EX4300, and EX4550 switches, you can also use the Mini-USB Type-B console port to connect to a laptop or PC. See [“Connecting an EX Series Switch to a Management Console by Using the Mini-USB Type-B Console Port” on page 149](#).

2. At the Junos OS shell prompt **root%**, type **ezsetup**.
3. Enter the hostname. This is optional.
4. Enter the root password you want to use for the device. Reenter the root password when prompted.

5. Enable services such as SSH and Telnet.



NOTE: You will not be able to log in to the switch as the root user through Telnet. Root login is allowed only through SSH.

- The default option for SSH is **yes**. Select this to enable SSH.
- The default option for Telnet is **no**. Change this to **yes** to enable Telnet.

6. Use the Management Options page to select the management scenario:



NOTE: On EX4500, EX6200, and EX8200 switches, only the out-of-band management option is available.

- *Configure in-band management.* In in-band management, you configure a network interface or an uplink module (expansion module) interface as the management interface and connect it to the management device. In this scenario, you have the following two options:
 - Use the automatically created VLAN *default* for management—Select this option to configure all data interfaces as members of the default VLAN. Specify the management IP address and the default gateway.
 - Create a new VLAN for management—Select this option to create a management VLAN. Specify the VLAN name, VLAN ID, management IP address, and default gateway. Select the ports that must be part of this VLAN.
- *Configure out-of-band management*—Configure the management port. In out-of-band management, you use a dedicated management channel (**MGMT** port) to connect to the management device. Specify the IP address and gateway of the management interface. Use this IP address to connect to the switch.

7. Specify the SNMP read community, location, and contact to configure SNMP parameters. These parameters are optional.
8. Specify the system date and time. Select the time zone from the list. These options are optional.
9. The configured parameters are displayed. Enter **yes** to commit the configuration. The configuration is committed as the active configuration for the switch.
10. (For EX4500 switches only) Enter the operational mode command **request chassis pic-mode intraconnect** to set the PIC mode to intraconnect.

You can now log in with the CLI or the J-Web interface to continue configuring the switch. If you use the J-Web interface to continue configuring the switch, the Web session is redirected to the new management IP address. If the connection cannot be made, the J-Web interface displays instructions for starting a J-Web session.

Related Documentation

- [Connecting and Configuring an EX Series Switch \(J-Web Procedure\) on page 162](#)
- [Installing and Connecting an EX2200 Switch](#)
- [Installing and Connecting an EX2300 Switch on page 103](#)
- [Installing and Connecting an EX3200 Switch](#)
- [Installing and Connecting an EX3300 Switch](#)
- [Installing and Connecting an EX3400 Switch](#)
- [Installing and Connecting an EX4200 Switch](#)
- [Installing and Connecting an EX4300 Switch](#)
- [Installing and Connecting an EX4550 Switch](#)
- [Installing and Connecting an EX4500 Switch](#)
- [Installing and Connecting an EX6210 Switch](#)
- [Installing and Connecting an EX8208 Switch](#)
- [Installing and Connecting an EX8216 Switch](#)

Connecting and Configuring an EX Series Switch (J-Web Procedure)

There are two ways to connect and configure an EX Series switch: one method is through the console by using the CLI and the other is by using the J-Web interface.



NOTE: You cannot connect to and perform initial configuration of EX2200-24T-4G-DC and EX4600 switches using EZSetup procedure from the J-Web interface. For EX2200-24T-4G-DC switches, you must use EZSetup from the switch console, and for EX4600 switches, you must use the CLI procedure through the switch console.

This topic describes the J-Web procedure.



NOTE: Before you begin the configuration, enable a DHCP client on the management PC that you will connect to the switch so that the PC can obtain an IP address dynamically.



NOTE: Read the following steps before you begin the configuration. You must complete the initial configuration by using EZSetup within 10 minutes. The switch exits EZSetup after 10 minutes and reverts to the factory default configuration, and the PC loses connectivity to the switch.

- EX2200 and EX2200-C switch—The LEDs on the network ports on the front panel blink when the switch is in the initial setup mode.
 - EX3200, EX3300, EX4200, EX4300, EX4500, EX4550, EX6200, or EX8200 switch—The LCD panel displays a count-down timer when the switch is in initial setup mode.
-

To connect and configure the switch by using the J-Web interface:

1. Transition the switch into initial setup mode:
 - EX2200 and EX2200-C switch—Press the mode button located on the lower right corner of the front panel for 10 seconds.
 - EX3200, EX3300, EX4200, EX4300, EX4500, EX4550, EX6200, or EX8200 switch—Use the **Menu** and **Enter** buttons located to the right of the LCD panel (see [Figure 68 on page 164](#) or [Figure 69 on page 164](#)):

Figure 68: LCD Panel in an EX3200, EX4200, EX4500, EX4550, or EX8200 Switch

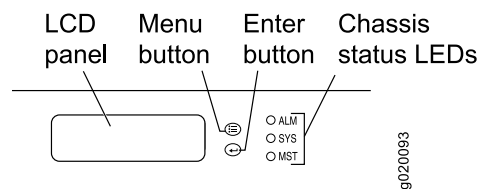
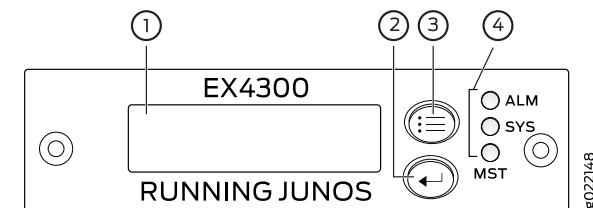

Figure 69: LCD Panel in an EX4300 Switch



1—LCD panel	3—LCD panel Menu button
2—LCD panel Enter button	4—Chassis status LEDs

1. Press the **Menu** button until you see **MAINTENANCE MENU**. Then press the **Enter** button.
 2. Press **Menu** until you see **ENTER EZSetup**. Then press **Enter**.

If EZSetup does not appear as an option in the menu, select **Factory Default** to return the switch to the factory default configuration. EZSetup is displayed in the menu of standalone switches only when a switch is set to the factory default configuration.
 3. Press **Enter** to confirm setup and continue with EZSetup.
2. Connect the Ethernet cable from the Ethernet port on the PC to the switch.
 - EX2200, EX3200, or EX4200 switch—Connect the cable to port 0 (ge-0/0/0) on the front panel of the switch.
 - EX3300, EX4500, or EX4550 switch—Connect the cable to the port labeled **MGMT** on the front panel (LCD panel side) of the switch.
 - EX4300 switch—Connect the cable to the port labeled **MGMT** on the rear panel of the switch.

- EX6200 switch—Connect the cable to one of the ports labeled **MGMT** on the Switch Fabric and Routing Engine (SRE) module in slot 4 or 5 in an EX6210 switch.
- EX8200 switch—Connect the cable to the port labeled **MGMT** on the Switch Fabric and Routing Engine (SRE) module in slot SRE0 in an EX8208 switch or on the Routing Engine (RE) module in slot RE0 in an EX8216 switch.

These ports are configured as the DHCP server with the default IP address, 192.168.1.1. The switch can assign an IP address to the management PC in the IP address range 192.168.1.2 through 192.168.1.253.

3. From the PC, open a Web browser, type **http://192.168.1.1** in the address field, and press **Enter**.
4. On the J-Web login page, type **root** as the username, leave the password field blank, and click **Login**.
5. On the Introduction page, click **Next**.
6. On the Basic Settings page, modify the hostname, the root password, and date and time settings:
 - Enter the hostname. This is optional.
 - Enter a password and reenter the password.
 - Specify the time zone.
 - Synchronize the date and time settings of the switch with the management PC or set them manually by selecting the appropriate option button. This is optional.

Click **Next**.

7. Use the Management Options page to select the management scenario:



NOTE: On EX4500, EX6210, and EX8200 switches, only the out-of-band management option is available.

- **In-band Management—Use VLAN 'default' for management.**

Select this option to configure all data interfaces as members of the default VLAN. Click **Next**. Specify the management IP address and the default gateway for the default VLAN.

- **In-band Management—Create new VLAN for management.**

Select this option to create a management VLAN. Click **Next**. Specify the VLAN name, VLAN ID, member interfaces, management IP address, and default gateway for the new VLAN.

- **Out-of-band Management—Configure management port.**

Select this option to configure only the management interface. Click **Next**. Specify the IP address and default gateway for the management interface.

8. Click **Next**.
9. On the Manage Access page, you can select options to enable Telnet, SSH, and SNMP services. For SNMP, you can configure the read community, location, and contact.
10. Click **Next**. The Summary screen displays the configured settings.
11. Click **Finish**. The configuration is committed as the active switch configuration.



NOTE: After the configuration is committed, the connectivity between the PC and the switch might be lost. To renew the connection, release and renew the IP address by executing the appropriate commands on the management PC or by removing and reinserting the Ethernet cable.

12. (For EX4500 switches only) In the CLI, enter the **request chassis pic-mode intraconnect** operational mode command to set the PIC mode to intraconnect.

You can now log in by using the CLI or the J-Web interface to continue configuring the switch.

If you use the J-Web interface to continue configuring the switch, the Web session is redirected to the new management IP address. If the connection cannot be made, the J-Web interface displays instructions for starting a J-Web session.

Related Documentation

- [Connecting and Configuring an EX Series Switch \(CLI Procedure\) on page 159](#)
- [Installing and Connecting an EX2200 Switch](#)
- [Installing and Connecting an EX2300 Switch on page 103](#)
- [Installing and Connecting an EX3200 Switch](#)
- [Installing and Connecting an EX3300 Switch](#)
- [Installing and Connecting an EX4200 Switch](#)
- [Installing and Connecting an EX4300 Switch](#)
- [Installing and Connecting an EX4500 Switch](#)
- [Installing and Connecting an EX4550 Switch](#)
- [Installing and Connecting an EX4600 Switch](#)
- [Installing and Connecting an EX6210 Switch](#)
- [Installing and Connecting an EX8208 Switch](#)
- [Installing and Connecting an EX8216 Switch](#)

Reverting to the Default Factory Configuration for the EX Series Switch

If for any reason the current active configuration fails, you can revert to the factory-default configuration.

You can also roll back to a previous configuration, as described in *Loading a Previous Configuration File (CLI Procedure)*, or revert to the rescue configuration, as described in *Reverting to the Rescue Configuration for the EX Series Switch*.



TIP: If you have lost the root password, it is not necessary to revert to the factory-default configuration to reset it. See *Troubleshooting Loss of the Root Password*.

The factory-default configuration contains the basic configuration settings for the switch. This is the first configuration of the switch and it is loaded when the switch is first powered on. For the factory-default configuration file for your switch, see the hardware documentation for your switch.



TIP: You can run the EZsetup script to complete the initial configuration of the switch *after* reverting to the factory-default configuration. (The EZsetup script is available only on fixed configuration switches, it is not available on modular switches.) For information on completing the initial configuration using either the CLI or the J-Web interface, see [“Connecting and Configuring an EX Series Switch \(CLI Procedure\)” on page 159](#) or [“Connecting and Configuring an EX Series Switch \(J-Web Procedure\)” on page 162](#).

You can revert to the factory-default configuration by using the **Menu** button to the right of the LCD panel or by using the **request system zeroize** operational command or the **load factory-default** configuration command. (If your switch model does not have an LCD panel, use these commands.) You can also use the **load factory-default** command to revert to the factory-default configuration file that contains all default settings *except* the root password setting, which is retained.

These procedures are described in the following sections:

- [Reverting to the Factory-Default Configuration by Using the LCD Panel on page 168](#)
- [Reverting to the Factory-Default Configuration by Using the request system zeroize Command on page 168](#)
- [Reverting to the Factory-Default Configuration by Using the load factory-default Command on page 169](#)
- [Reverting to the Factory-Default Configuration by Using the Factory Reset/Mode button on EX2300 and EX3400 Switches on page 170](#)

Reverting to the Factory-Default Configuration by Using the LCD Panel

To set the switch to the factory-default configuration, use the LCD panel and buttons on the front panel of the switch shown in [Figure 70 on page 168](#). If the switch model does not have an LCD panel, use one of the procedures described in the following sections.

Figure 70: EX Series Switch LCD Panel

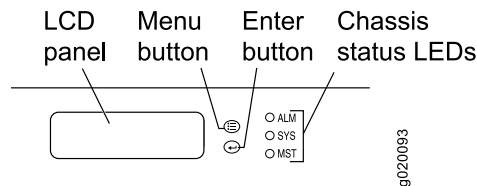

NOTE: To revert a member switch of a Virtual Chassis to the factory-default configuration, first disconnect the cables connected to the Virtual Chassis ports (VCPs) to avoid affecting Virtual Chassis configuration parameters (member ID, mastership priority, and setting of VCP uplinks) on other members. See [“Disconnecting a Fiber-Optic Cable from a Device” on page 182](#), [Disconnecting a Virtual Chassis Cable from an EX4200 Switch](#), or [Disconnecting a Virtual Chassis Cable from an EX4500 Switch](#).

To revert to the factory-default configuration by using the LCD panel:

1. Press the **Menu** button until you see MAINTENANCE MENU on the panel.
2. Press the **Enter** button.
3. Press **Menu** until you see FACTORY DEFAULT.
4. Press **Enter**. The display says RESTORE DEFAULT?
5. Press **Enter**. The screen flashes **FACTORY DEFAULT IN PROGRESS** and returns to the idle menu.
6. Complete the initial configuration of the switch. See [“Connecting and Configuring an EX Series Switch \(CLI Procedure\)” on page 159](#) or [“Connecting and Configuring an EX Series Switch \(J-Web Procedure\)” on page 162](#).

Reverting to the Factory-Default Configuration by Using the request system zeroize Command

The **request system zeroize** command is a standard Junos OS operational mode command that removes all configuration information and resets all key values. The operation unlinks all user-created data files, including customized configuration and log files, from their directories. The switch then reboots and reverts to the factory-default configuration.

To completely erase user-created data so that it is unrecoverable, use the **request system zeroize media** command.



CAUTION: Before issuing **request system zeroize**, use the **request system snapshot** command to back up the files currently used to run the switch to a secondary device.

To revert to the factory-default configuration by using the **request system zeroize** command:

1. user@switch> **request system zeroize**
warning: System will be rebooted and may not boot without configuration
Erase all data, including configuration and log files? [yes,no] (yes)
2. Type **yes** to remove configuration and log files and revert to the factory-default configuration.



NOTE: The **auto-image-upgrade** statement is added under the [edit chassis] hierarchy level when you use this procedure, and thus the automatic image upgrade feature is made available on the switch.

Reverting to the Factory-Default Configuration by Using the **load factory-default** Command

The **load factory-default** command is a standard Junos OS configuration command that replaces the current active configuration with the factory-default configuration (except the root password setting, which by default is not set but which you must set in order to commit the new configuration in this procedure).

If you want to run the EZsetup script to complete the initial configuration of the switch after you revert to the factory-default configuration, do not use the **load factory-default** command. Instead do the reversion using either the LCD panel or the **request system zeroize** command. If you use the **load factory-default** command to revert to the factory-default configuration, the configuration for the root password is retained and the EZsetup script will not run. (The EZsetup script is available only on fixed configuration switches, it is not available on modular switches.)



NOTE: The **load factory-default** command by itself is not supported on EX3300, EX4200, EX4500, and EX4550 switches configured in a Virtual Chassis.

To revert to the factory-default configuration by using the **load factory-default** command:



NOTE: If you use this procedure, you must delete the system commit factory settings, set the root password, and commit the configuration. These steps are not required when you revert to the factory-default configuration by using `request system zeroize`. Also, the `auto-image-upgrade` statement is not added to the configuration when you use this procedure; it *is* added to the configuration when you use `request system zeroize`.

1. [edit]
user@switch# **load factory-default**
2. [edit]
user@switch# **delete system commit factory-settings**
3. [edit]
user@switch# **set system root-authentication plain-text-password**
4. [edit]
user@switch# **commit**
5. Check the member ID and mastership priority with the `show virtual-chassis` command and check to see whether there are remaining settings for uplink VCPs by using the `show virtual-chassis vc-port` command.

Reverting to the Factory-Default Configuration by Using the Factory Reset/Mode button on EX2300 and EX3400 Switches

To set the EX2300, EX2300-C, and EX3400 switches to the factory-default configuration, use the Factory Reset/Mode button located on the far right side of the front panel.



NOTE: To revert a member switch of a Virtual Chassis to the factory-default configuration, disconnect the cables connected to the VCPs to avoid affecting Virtual Chassis configuration parameters (member ID, mastership priority, and setting of VCP uplinks) on other members. See [“Disconnecting a Fiber-Optic Cable from a Device” on page 182](#).

To revert to the factory-default configuration by using the Factory Reset/Mode button:

1. Press the Factory Reset/Mode button for 10 seconds. The switch transitions into factory-default configuration and the console displays **committing factory default configuration**.
2. Press the Factory Reset/Mode button for 10 more seconds. The switch transitions into initial setup mode and the console displays **committing ezsetup config**.

**Related
Documentation**

- [Connecting and Configuring an EX Series Switch \(CLI Procedure\) on page 159](#)
- [Connecting and Configuring an EX Series Switch \(J-Web Procedure\) on page 162](#)
- [Configuring an EX4200, EX4500, or EX4550 Virtual Chassis \(CLI Procedure\)](#)
- [Understanding Configuration Files for EX Series Switches](#)
- [For more information about the load factory-default command, see *Junos OS CLI User Guide*.](#)

PART 4

Installing, Maintaining, and Replacing Components

- [Replacing Transceiver on page 175](#)
- [Maintaining and Replacing Fiber-Optic Cable on page 181](#)
- [Contacting Customer Support and Returning the Chassis or Components on page 185](#)

Replacing Transceiver

- [Installing a Transceiver on page 175](#)
- [Removing a Transceiver on page 177](#)

Installing a Transceiver

The transceivers for Juniper Networks devices are hot-removable and hot-insertable field-replaceable units (FRUs): You can remove and replace them without powering off the device or disrupting the device functions.



NOTE: After you insert a transceiver or after you change the media-type configuration, wait for 6 seconds for the interface to display operational commands.



NOTE: We recommend that you use only optical transceivers and optical connectors purchased from Juniper Networks with your Juniper Networks device.



CAUTION: If you face a problem running a Juniper Networks device that uses a third-party optic or cable, the Juniper Networks Technical Assistance Center (JTAC) can help you diagnose the source of the problem. Your JTAC engineer might recommend that you check the third-party optic or cable and potentially replace it with an equivalent Juniper Networks optic or cable that is qualified for the device.



NOTE: On an EX3200 switch, if you install a transceiver in a 1-Gigabit Ethernet uplink module port, a corresponding network port from the last four built-in ports is disabled. For example, if you install a transceiver in the uplink module port 3 (ge-0/1/2), then the built-in port 23 (ge-0/0/22) is disabled. The disabled port is not listed in the output of show interface commands.

Before you begin installing a transceiver in a device, ensure that you have taken the necessary precautions for safe handling of lasers (see “[Laser and LED Safety Guidelines and Warnings](#)” on page 231).

Ensure that you have a rubber safety cap available to cover the transceiver.

[Figure 71 on page 177](#) shows how to install a QSFP+ transceiver. The procedure is the same for all types of transceivers except the CFP transceivers.

To install a transceiver:



CAUTION: To prevent electrostatic discharge (ESD) damage to the transceiver, do not touch the connector pins at the end of the transceiver.

1. Remove the transceiver from its bag.
2. Check to see whether the transceiver is covered with a rubber safety cap. If it is not, cover the transceiver with a rubber safety cap.



WARNING: Do not leave a fiber-optic transceiver uncovered except when inserting or removing a cable. The rubber safety cap keeps the port clean and prevents accidental exposure to laser light.

3. If the port in which you want to install the transceiver is covered with a dust cover, remove the dust cover and save it in case you need to cover the port later. If you are hot-swapping a transceiver, wait for at least 10 seconds after removing the transceiver from the port before installing a new transceiver.
4. Using both hands, carefully place the transceiver in the empty port. The connectors must face the chassis.



CAUTION: Before you slide the transceiver into the port, ensure that the transceiver is aligned correctly. Misalignment might cause the pins to bend, making the transceiver unusable.

5. Slide the transceiver in gently until it is fully seated. If you are installing a CFP transceiver, tighten the captive screws on the transceiver by using your fingers.
6. Remove the rubber safety cap when you are ready to connect the cable to the transceiver.



WARNING: Do not look directly into a fiber-optic transceiver or into the ends of fiber-optic cables. Fiber-optic transceivers and fiber-optic cables connected to transceivers emit laser light that can damage your eyes.

Figure 71: Installing a Transceiver

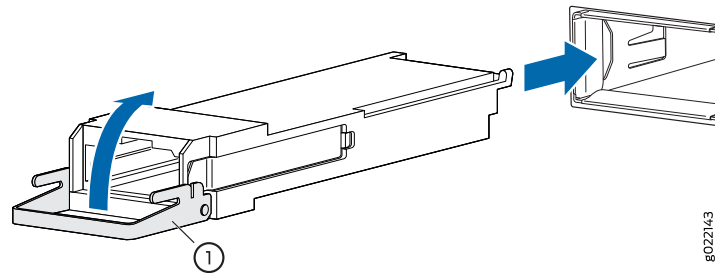

1— Ejector lever

Related Documentation

- [Removing a Transceiver on page 177](#)
- [Connecting a Fiber-Optic Cable on page 151](#)

Removing a Transceiver

The transceivers for Juniper Networks devices are hot-removable and hot-insertable field-replaceable units (FRUs): You can remove and replace them without powering off the device or disrupting device functions.



NOTE: After you remove a transceiver or when you change the media-type configuration, wait for 6 seconds for the interface to display the operational commands.

Before you begin removing a transceiver from a device, ensure that you have taken the necessary precautions for safe handling of lasers (see “[Laser and LED Safety Guidelines and Warnings](#)” on page 231).

Ensure that you have the following parts and tools available:

- An antistatic bag or an antistatic mat
- Rubber safety caps to cover the transceiver and fiber-optic cable connector
- A dust cover to cover the port

[Figure 72 on page 179](#) shows how to remove a QSFP+ transceiver. The procedure is the same for all types of transceivers except the CFP transceivers.

To remove a transceiver from a device:

1. Place the antistatic bag or antistatic mat on a flat, stable surface.
2. Label the cable connected to the transceiver so that you can reconnect it correctly.



WARNING: Do not look directly into a fiber-optic transceiver or into the ends of fiber-optic cables. Fiber-optic transceivers and fiber-optic cables connected to transceivers emit laser light that can damage your eyes.



WARNING: Do not leave a fiber-optic transceiver uncovered except when inserting or removing a cable. The rubber safety cap keeps the port clean and prevents accidental exposure to laser light.



CAUTION: Do not bend fiber-optic cables beyond their minimum bend radius. An arc smaller than a few inches in diameter can damage the cables and cause problems that are difficult to diagnose.

3. Remove the cable connected to the transceiver (see [“Disconnecting a Fiber-Optic Cable from a Device” on page 182](#)). Cover the transceiver and the end of each fiber-optic cable connector with a rubber safety cap immediately after disconnecting the fiber-optic cables.

4. To remove an SFP, SFP+, XFP, or a QSFP+ transceiver:

- a. By using your fingers, pull open the ejector lever on the transceiver to unlock the transceiver.



CAUTION: Before removing the transceiver, make sure that you open the ejector lever completely until you hear it click. This prevents damage to the transceiver.

- b. Grasp the transceiver ejector lever and gently slide the transceiver approximately 0.5 in. (1.3 cm) straight out of the port.



CAUTION: To prevent electrostatic discharge (ESD) damage to the transceiver, do not touch the connector pins at the end of the transceiver.

To remove a CFP transceiver:

- a. Loosen the screws on the transceiver by using your fingers.
- b. Grasp the screws on the transceiver and gently slide the transceiver approximately 0.5 in. (1.3 cm) straight out of the port.



CAUTION: To prevent electrostatic discharge (ESD) damage to the transceiver, do not touch the connector pins at the end of the transceiver.

Figure 72: Removing an SFP, SFP+, XFP, or a QSFP+ Transceiver

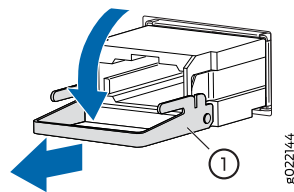

1—Ejector lever

5. By using your fingers, grasp the body of the transceiver and pull it straight out of the port.

6. Place the transceiver in the antistatic bag or on the antistatic mat placed on a flat, stable surface.
7. Place the dust cover over the empty port.

Related Documentation

- [Installing a Transceiver on page 175](#)

Maintaining and Replacing Fiber-Optic Cable

- [Connecting a Fiber-Optic Cable on page 181](#)
- [Disconnecting a Fiber-Optic Cable from a Device on page 182](#)
- [Maintaining Fiber-Optic Cables on page 183](#)

Connecting a Fiber-Optic Cable

Before you begin connecting a fiber-optic cable to an optical transceiver installed in a device, ensure that you have taken the necessary precautions for safe handling of lasers (see “[Laser and LED Safety Guidelines and Warnings](#)” on page 231).

To connect a fiber-optic cable to an optical transceiver installed in a device:



WARNING: Do not look directly into a fiber-optic transceiver or into the ends of fiber-optic cables. Fiber-optic transceivers and fiber-optic cables connected to transceivers emit laser light that can damage your eyes.

1. If the fiber-optic cable connector is covered with a rubber safety cap, remove the cap. Save the cap.
2. Remove the rubber safety cap from the optical transceiver. Save the cap.
3. Insert the cable connector into the optical transceiver (see [Figure 67 on page 151](#)).

Figure 73: Connecting a Fiber-Optic Cable to an Optical Transceiver Installed in a Device

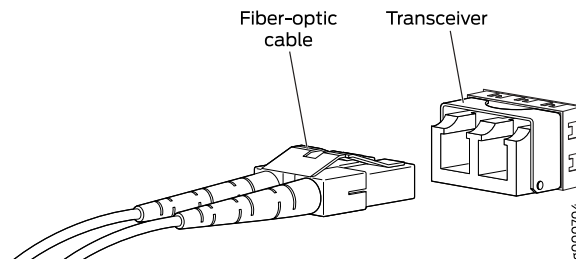

- Secure the cables so that they do not support their own weight. Place excess cable out of the way in a neatly coiled loop. Placing fasteners on a loop helps cables maintain their shape.



CAUTION: Do not bend fiber-optic cables beyond their minimum bend radius. An arc smaller than a few inches in diameter can damage the cables and cause problems that are difficult to diagnose.

Do not let fiber-optic cables hang free from the connector. Do not allow fastened loops of cables to dangle, which stresses the cables at the fastening point.

Related Documentation

- [Disconnecting a Fiber-Optic Cable from a Device on page 182](#)
- [Installing a Transceiver on page 175](#)
- [Maintaining Fiber-Optic Cables on page 183](#)

Disconnecting a Fiber-Optic Cable from a Device

Juniper Networks devices have field-replaceable unit (FRU) optical transceivers to which you can connect fiber-optic cables.

Before you begin disconnecting a fiber-optic cable from an optical transceiver, ensure that you have taken the necessary precautions for safe handling of lasers. See "[Laser and LED Safety Guidelines and Warnings](#)" on page 231.

Ensure that you have the following parts and tools available:

- A rubber safety cap to cover the transceiver
- A rubber safety cap to cover the fiber-optic cable connector

To disconnect a fiber-optic cable from an optical transceiver installed in the device:

1. Disable the port in which the transceiver is installed by issuing the following command:

```
[edit interfaces]
user@device# set interface-name disable
```



WARNING: Do not look directly into a fiber-optic transceiver or into the ends of fiber-optic cables. Fiber-optic transceivers and fiber-optic cables connected to transceivers emit laser light that can damage your eyes.

2. Carefully unplug the fiber-optic cable connector from the transceiver.
3. Cover the transceiver with a rubber safety cap.



WARNING: Do not leave a fiber-optic transceiver uncovered except when inserting or removing a cable. The rubber safety cap keeps the port clean and prevents accidental exposure to laser light.

4. Cover the fiber-optic cable connector with the rubber safety cap.

Related Documentation

- [Connecting a Fiber-Optic Cable on page 151](#)
- [Removing a Transceiver on page 177](#)
- [Maintaining Fiber-Optic Cables on page 183](#)

Maintaining Fiber-Optic Cables

Fiber-optic cables connect to optical transceivers that are installed in Juniper Networks devices.

To maintain fiber-optic cables:

- When you unplug a fiber-optic cable from a transceiver, place rubber safety caps over the transceiver and on the end of the cable.
- Anchor fiber-optic cables to prevent stress on the connectors. When attaching a fiber-optic cable to a transceiver, be sure to secure the fiber-optic cable so that it does not support its own weight as it hangs to the floor. Never let a fiber-optic cable hang free from the connector.
- Avoid bending fiber-optic cables beyond their minimum bend radius. Bending fiber-optic cables into arcs smaller than a few inches in diameter can damage the cables and cause problems that are difficult to diagnose.

- Frequent plugging and unplugging of fiber-optic cables in and out of optical instruments can damage the instruments, which are expensive to repair. Attach a short fiber extension to the optical equipment. Any wear and tear due to frequent plugging and unplugging is then absorbed by the short fiber extension, which is easier and less expensive to replace than the instruments.
- Keep fiber-optic cable connections clean. Microdeposits of oil and dust in the canal of the transceiver or cable connector can cause loss of light, reduction in signal power, and possibly intermittent problems with the optical connection.
 - To clean the transceiver canal, use an appropriate fiber-cleaning device such as RIFOCS Fiber Optic Adaptor Cleaning Wands (part number 946). Follow the directions in the cleaning kit you use.
 - After cleaning the transceiver, make sure that the connector tip of the fiber-optic cable is clean. Use only an approved alcohol-free fiber-optic cable cleaning kit such as the Opptex Cletop-S Fiber Cleaner. Follow the directions in the cleaning kit you use.

**Related
Documentation**

- [Connecting a Fiber-Optic Cable on page 151](#)
- [Laser and LED Safety Guidelines and Warnings on page 231](#)

Contacting Customer Support and Returning the Chassis or Components

- [Returning an EX2300 Switch or Component for Repair or Replacement on page 185](#)
- [Locating the Serial Number on an EX2300 Switch or Component on page 186](#)
- [Contacting Customer Support to Obtain Return Material Authorization on page 187](#)
- [Packing an EX2300 Switch or Component for Shipping on page 188](#)

Returning an EX2300 Switch or Component for Repair or Replacement

If you need to return an EX2300 switch or hardware component to Juniper Networks for repair or replacement, follow this procedure:

1. Determine the serial number of the component. For instructions, see [“Locating the Serial Number on an EX2300 Switch or Component” on page 186](#).
2. Obtain a Return Material Authorization (RMA) number from JTAC as described in [“Contacting Customer Support to Obtain Return Material Authorization” on page 187](#).



NOTE: Do not return any component to Juniper Networks unless you have first obtained an RMA number. Juniper Networks reserves the right to refuse shipments that do not have an RMA number. Refused shipments are returned to the customer through collect freight.

3. Pack the switch or component for shipping as described in [“Packing an EX2300 Switch or Component for Shipping” on page 188](#).

For more information about return and repair policies, see the customer support page at <http://www.juniper.net/support/guidelines.html>.

Related Documentation

- [EX2300 Switches Hardware Overview on page 3](#)

Locating the Serial Number on an EX2300 Switch or Component

If you are returning an EX2300 switch or hardware component to Juniper Networks for repair or replacement, you must locate the serial number of the switch or component. You must provide the serial number to the Juniper Networks Technical Assistance Center (JTAC) when you contact them to obtain a Return Material Authorization (RMA) number.

If the switch is operational and you can access the CLI, you can list serial numbers for the switch and for some components with a CLI command. If you do not have access to the CLI or if the serial number does not appear in the command output, you can locate the serial number ID label on the physical switch (see [Figure 75 on page 187](#)) or component.



NOTE: If you want to find the serial number on the physical switch component, you need to remove the component from the switch chassis, for which you must have the required parts and tools available.

- [Listing the Switch and Components Details with the CLI on page 186](#)
- [Locating the Chassis Serial Number ID Label on an EX2300 Switch on page 187](#)

Listing the Switch and Components Details with the CLI

To list the switch and switch components and their serial numbers, enter the following CLI command:

```
user@switch> show chassis hardware
```

The following are sample output of this command on EX2300-C and EX2300 switches:

```
Hardware inventory:
Item          Version  Part number  Serial number  Description
Chassis
Pseudo CB 0
Routing Engine 0
FPC 0         REV 04   650-059984  HV0215410003  EX2300-C-12P
  CPU         BUILTIN  BUILTIN     FPC CPU
  PIC 0       REV 04   BUILTIN     BUILTIN     12x10/100/1000 Base-T
  PIC 1       REV 04   650-059984  HV0215410003  2x10G SFP/SFP+
    Xcvr 0    REV 01   740-021309  T09K00695    SFP+-10G-LR
    Xcvr 1    REV 01   740-030658  AD1146A05JT  SFP+-10G-USR
Power Supply 0
JPSU-170W-AC
```

```
Hardware inventory:
Item          Version  Part number  Serial number  Description
Chassis
Pseudo CB 0
Routing Engine 0
FPC 0         REV 05   650-059968  JY0215410033  EX2300-24P
  CPU         BUILTIN  BUILTIN     FPC CPU
  PIC 0       REV 05   BUILTIN     BUILTIN     24x10/100/1000 Base-T
  PIC 1       REV 05   650-059968  JY0215410033  4x10G SFP/SFP+
    Xcvr 0    REV 01   740-030658  AD1125A03ES  SFP+-10G-USR
    Xcvr 1    REV 01   740-021308  AJPOTDZ      SFP+-10G-SR
    Xcvr 3    REV 01   740-021309  A9401FL      SFP+-10G-LR
Power Supply 0
JPSU-450W-AC-AFO
```

Fan Tray 0 (AFO)	Fan Module, Airflow Out
Fan Tray 1 (AFO)	Fan Module, Airflow Out

Locating the Chassis Serial Number ID Label on an EX2300 Switch

EX2300 switches have serial number ID labels located on the rear panel of the chassis (see and [Figure 74 on page 187](#)/[Figure 75 on page 187](#)).

Figure 74: Location of the Serial Number ID Label on EX2300-C Switches

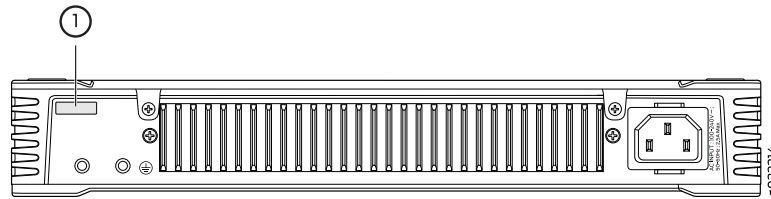
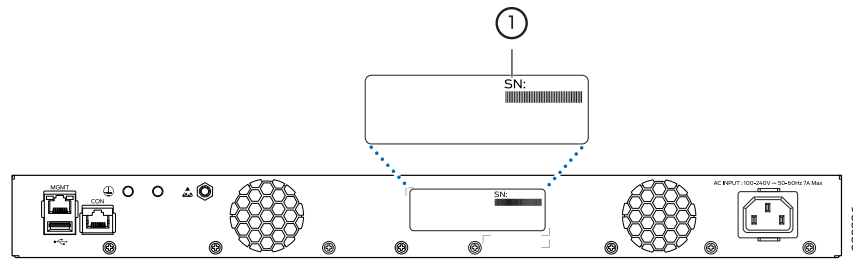

Figure 75: Location of the Serial Number ID Label on EX2300 Switches Except EX2300-C Switches



Related Documentation

- [Contacting Customer Support to Obtain Return Material Authorization on page 187](#)
- [Returning an EX2300 Switch or Component for Repair or Replacement on page 185](#)

Contacting Customer Support to Obtain Return Material Authorization

If you are returning a device or hardware component to Juniper Networks for repair or replacement, obtain a Return Material Authorization (RMA) number from Juniper Networks Technical Assistance Center (JTAC).

After locating the serial number of the device or hardware component you want to return, open a Case with Juniper Networks Technical Assistance Center (JTAC) on the Web or by telephone.

Before you request an RMA number from JTAC, be prepared to provide the following information:

- Your existing case number, if you have one
- Serial number of the component

- Your name, organization name, telephone number, fax number, and shipping address
- Details of the failure or problem
- Type of activity being performed on the device when the problem occurred
- Configuration data displayed by one or more **show** commands

You can contact JTAC 24 hours a day, seven days a week on the Web or by telephone:

- Case Manager at CSC: <http://www.juniper.net/cm/>
- Telephone: +1-888-314-JTAC1-888-314-5822, toll free in U.S., Canada, and Mexico



NOTE: For international or direct-dial options in countries without toll free numbers, see <http://www.juniper.net/support/requesting-support.html>.

If you are contacting JTAC by telephone, enter your 12-digit case number followed by the pound (#) key for an existing case, or press the star (*) key to be routed to the next available support engineer.

The support representative validates your request and issues an RMA number for return of the component.

**Related
Documentation**

- [Prevention of Electrostatic Discharge Damage on page 243](#)

Packing an EX2300 Switch or Component for Shipping

If you are returning an EX2300 switch or component to Juniper Networks for repair or replacement, pack the item as described in this topic.

Before you begin, ensure that you have retrieved the original shipping carton and packing materials. Contact your JTAC representative if you do not have these materials, to learn about approved packing materials. See “[Contacting Customer Support to Obtain Return Material Authorization](#)” on page 187.

Ensure that you have the following parts and tools available:

- Antistatic bag, one for each switch or component
- Phillips (+) screwdriver, number 2

This topic describes:

- [Packing a Switch for Shipping on page 189](#)
- [Packing Switch Components for Shipping on page 190](#)

Packing a Switch for Shipping

To pack a switch for shipping:

1. On the console or other management device connected to the switch, enter the CLI operational mode and issue the following command to shut down the switch software:

```
user@switch> request system halt
```

Wait until a message appears on the console confirming that the operating system has halted.

2. Disconnect power from the switch by performing one of the following:
 - If the power source outlet has a power switch, set it to the off (O) position.
 - If the power source outlet does not have a power switch, gently pull out the male end of the power cord connected to the power source outlet.
3. Remove the cables that connect the switch to all external devices. See [“Disconnecting a Fiber-Optic Cable from a Device” on page 182](#).
4. Remove all optical transceivers installed in the switch. See [“Removing a Transceiver” on page 177](#).
5. If the switch is mounted on a wall or on two posts, have one person hold the switch while another person unscrews and removes the mounting screws. Use the Phillips (+) screwdriver, number 2 to remove the screws.
6. Remove the switch from the wall, rack, cabinet, or desk and place the switch in an antistatic bag.
7. Slip on the end caps of the packaging foam on both sides of the switch.
8. Place the switch in the shipping carton.
9. Place the packing foam on top of and around the switch.
10. If you are returning accessories or FRUs with the switch, pack them as instructed in [“Packing Switch Components for Shipping” on page 190](#).
11. Close the top of the cardboard carton and seal it with packing tape.
12. Write the RMA number on the exterior of the carton to ensure proper tracking.

Packing Switch Components for Shipping

To pack and ship switch components:

- Place individual components in antistatic bags.
- Ensure that the components are adequately protected with packing materials and packed so that the pieces are prevented from moving around inside the carton.
- Close the top of the cardboard shipping carton and seal it with packing tape.
- Write the RMA number on the exterior of the carton to ensure proper tracking.

Related Documentation

- [Returning an EX2300 Switch or Component for Repair or Replacement on page 185](#)

PART 5

Troubleshooting

- [Alarms and System Log Messages on page 193](#)
- [Troubleshooting Switch Components on page 203](#)

Alarms and System Log Messages

- [Understanding Alarm Types and Severity Levels on EX Series Switches on page 193](#)
- [Chassis Component Alarm Conditions on EX2300 Switches on page 194](#)
- [Checking Active Alarms with the J-Web Interface on page 196](#)
- [Monitoring System Log Messages on page 197](#)

Understanding Alarm Types and Severity Levels on EX Series Switches



NOTE: This topic applies only to the J-Web Application package.

Alarms alert you to conditions that might prevent normal operation of the switch. Before monitoring alarms on a Juniper Networks EX Series Ethernet switch, become familiar with the terms defined in [Table 54 on page 193](#).

Table 54: Alarm Terms

Term	Definition
alarm	Signal alerting you to conditions that might prevent normal operation. On a switch, the alarm signal is the ALM LED lit on the front of the chassis.
alarm condition	Failure event that triggers an alarm.
alarm severity	Seriousness of the alarm. If the Alarm (ALM) LED is red, this indicates a major alarm. If the Alarm LED is yellow, this indicates a minor alarm. If the Alarm LED is unlit, there is no alarm or the switch is halted.
chassis alarm	Preset alarm triggered by a physical condition on the switch such as a power supply failure, excessive component temperature, or media failure.
system alarm	Preset alarm triggered by a missing rescue configuration or failure to install a license for a licensed software feature. NOTE: On EX6200 switches, a system alarm can be triggered by an internal link error.

Alarm Types

The switch supports these alarms:

- Chassis alarms indicate a failure on the switch or one of its components. Chassis alarms are preset and cannot be modified.
- System alarms indicate a missing rescue configuration. System alarms are preset and cannot be modified, although you can configure them to appear automatically in the J-Web interface display or the CLI display.

Alarm Severity Levels

Alarms on switches have two severity levels:

- Major (red)—Indicates a critical situation on the switch that has resulted from one of the following conditions. A red alarm condition requires immediate action.
 - One or more hardware components have failed.
 - One or more hardware components have exceeded temperature thresholds.
 - An alarm condition configured on an interface has triggered a critical warning.
- Minor (yellow or amber)—Indicates a noncritical condition on the switch that, if left unchecked, might cause an interruption in service or degradation in performance. A yellow alarm condition requires monitoring or maintenance.

A missing rescue configuration generates a yellow system alarm.

Related Documentation

- [Checking Active Alarms with the J-Web Interface on page 196](#)
- [Dashboard for EX Series Switches on page 31](#)

Chassis Component Alarm Conditions on EX2300 Switches

This topic describes the chassis component alarm conditions on EX2300 switches.

[Table 55 on page 195](#) lists the alarm conditions on EX2300 switches, their severity levels, and the actions you can take to respond to them.

Table 55: Alarm Conditions on EX2300 Switches

Chassis Component	Alarm Condition	Alarm Severity	Remedy
Temperature	The temperature inside the chassis reaches the yellow alarm limit.	Minor (yellow)	<ul style="list-style-type: none"> Check the fan. Open a support case using the Case Manager link at http://www.juniper.net/support/ or call 1-888-314-5822 (toll-free within the United States and Canada) or 1-408-745-9500 (from outside the United States).
	The temperature inside the chassis reaches the red alarm limit.	Major (red)	<ul style="list-style-type: none"> Check the fan. Open a support case using the Case Manager link at http://www.juniper.net/support/ or call 1-888-314-5822 (toll-free within the United States and Canada) or 1-408-745-9500 (from outside the United States).
	The temperature sensor has failed.	Major (red)	Open a support case using the Case Manager link at http://www.juniper.net/support/ or call 1-888-314-5822 (toll-free within the United States and Canada) or 1-408-745-9500 (from outside the United States).
Management Ethernet interface	Management Ethernet link is down.	Major (red)	<ul style="list-style-type: none"> Check whether a cable is connected to the management Ethernet interface, or whether the cable is defective. Replace the cable if required. If you are unable to resolve the problem, open a support case using the Case Manager link at http://www.juniper.net/support/ or call 1-888-314-5822 (toll-free within the United States and Canada) or 1-408-745-9500 (from outside the United States).

Table 55: Alarm Conditions on EX2300 Switches (*continued*)

Chassis Component	Alarm Condition	Alarm Severity	Remedy
Routing Engine	<code>/var</code> partition usage is high.	Minor (yellow)	Clean up the system file storage space on the switch. For more information, see <i>Cleaning Up the System File Storage Space</i> .
	<code>/var</code> partition is full.	Major (red)	Clean up the system file storage space on the switch. For more information, see <i>Cleaning Up the System File Storage Space</i> .
	Rescue configuration is not set.	Minor (yellow)	Use the request system configuration rescue save command to set the rescue configuration. For more information, see <i>Setting or Deleting the Rescue Configuration (CLI Procedure)</i> .
	Feature usage requires a license or the license for the feature usage has expired.	Minor (yellow)	Install the required license for the feature specified in the alarm. For more information, see <i>Understanding Software Licenses for EX Series Switches</i> .

Related Documentation

- [Chassis Status LEDs in EX2300 Switches on page 16](#)
- [Understanding Alarm Types and Severity Levels on EX Series Switches on page 193](#)

Checking Active Alarms with the J-Web Interface

Purpose



NOTE: This topic applies only to the J-Web Application package.

Use the monitoring functionality to view alarm information for the EX Series switches including alarm type, alarm severity, and a brief description for each active alarm on the switching platform.

Action

To view the active alarms:

1. Select **Monitor > Events and Alarms > View Alarms** in the J-Web interface.
2. Select an alarm filter based on alarm type, severity, description, and date range.
3. Click **Go**.

All the alarms matching the filter are displayed.



NOTE: When the switch is reset, the active alarms are displayed.

Meaning Table 56 on page 197 lists the alarm output fields.

Table 56: Summary of Key Alarm Output Fields

Field	Values
Type	Category of the alarm: <ul style="list-style-type: none"> Chassis—Indicates an alarm condition on the chassis (typically an environmental alarm such as one related to temperature). System—Indicates an alarm condition in the system.
Severity	Alarm severity—either major (red) or minor (yellow).
Description	Brief synopsis of the alarm.
Time	Date and time when the failure was detected.

Related Documentation

- Monitoring System Log Messages on page 197
- Dashboard for EX Series Switches on page 31
- Understanding Alarm Types and Severity Levels on EX Series Switches on page 193

Monitoring System Log Messages

Purpose



NOTE: This topic applies only to the J-Web Application package.

Use the monitoring functionality to filter and view system log messages for EX Series switches.

Action

To view events in the J-Web interface, select Monitor > Events and Alarms > View Events.

Apply a filter or a combination of filters to view messages. You can use filters to display relevant events. Table 57 on page 198 describes the different filters, their functions, and the associated actions.

To view events in the CLI, enter the following command:

```
show log
```

Table 57: Filtering System Log Messages

Field	Function	Your Action
System Log File	<p>Specifies the name of a system log file for which you want to display the recorded events.</p> <p>Lists the names of all the system log files that you configure.</p> <p>By default, a log file, messages, is included in the <code>/var/log/</code> directory.</p>	<p>To specify events recorded in a particular file, select the system log filename from the list—for example, messages.</p> <p>Select Include archived files to include archived files in the search.</p>
Process	<p>Specifies the name of the process generating the events you want to display.</p> <p>To view all the processes running on your system, enter the CLI command show system processes.</p> <p>For more information about processes, see the Junos OS Installation and Upgrade Guide.</p>	<p>To specify events generated by a process, type the name of the process.</p> <p>For example, type mgd to list all messages generated by the management process.</p>
Date From To	<p>Specifies the time period in which the events you want displayed are generated.</p> <p>Displays a calendar that allows you to select the year, month, day, and time. It also allows you to select the local time.</p> <p>By default, the messages generated during the last one hour are displayed. End Time shows the current time and Start Time shows the time one hour before End Time.</p>	<p>To specify the time period:</p> <ul style="list-style-type: none"> Click the Calendar icon and select the year, month, and date—for example, 02/10/2007. Click the Calendar icon and select the year, month, and date—for example, 02/10/2007. Click to select the time in hours, minutes, and seconds.
Event ID	<p>Specifies the event ID for which you want to display the messages.</p> <p>Allows you to type part of the ID and completes the remainder automatically.</p> <p>An event ID, also known as a system log message code, uniquely identifies a system log message. It begins with a prefix that indicates the generating software process or library.</p>	<p>To specify events with a specific ID, type the partial or complete ID—for example, TFTPD_AF_ERR.</p>
Description	<p>Specifies text from the description of events that you want to display.</p> <p>Allows you to use regular expressions to match text from the event description.</p> <p>NOTE: Regular expression matching is case-sensitive.</p>	<p>To specify events with a specific description, type a text string from the description with regular expression.</p> <p>For example, type ^Initial* to display all messages with lines beginning with the term <i>Initial</i>.</p>
Search	<p>Applies the specified filter and displays the matching messages.</p>	<p>To apply the filter and display messages, click Search.</p>

Table 57: Filtering System Log Messages (*continued*)

Field	Function	Your Action
Reset	Resets all the fields in the Events Filter box.	To reset the field values that are listed in the Events Filter box, click Reset .
Generate Raw Report	Generates a list of event log messages in nontabular format.	To generate a raw report: <ol style="list-style-type: none"> Click Generate Raw Report. The <i>Opening filteredEvents.html</i> window appears. Select Open with to open the HTML file or select Save File to save the file. Click OK.
Generate Report	Generates a list of event log messages in tabular format, which shows system details, events filter criteria, and event details.	To generate a formatted report: <ol style="list-style-type: none"> Click Generate Report. The <i>Opening Report.html</i> window appears. Select Open with to open the HTML file or select Save File to save the file. Click OK.

Meaning Table 58 on page 200 describes the Event Summary fields.



NOTE: By default, the View Events page in the J-Web interface displays the most recent 25 events, with severity levels highlighted in different colors. After you specify the filters, Event Summary displays the events matching the specified filters. Click the First, Next, Prev, and Last links to navigate through messages.

Table 58: Viewing System Log Messages

Field	Function	Additional Information
Process	Displays the name and ID of the process that generated the system log message.	The information displayed in this field is different for messages generated on the local Routing Engine than for messages generated on another Routing Engine (on a system with two Routing Engines installed and operational). Messages from the other Routing Engine also include the identifiers <code>re0</code> and <code>re1</code> that identify the Routing Engine.
Severity	<p>Severity level of a message is indicated by different colors.</p> <ul style="list-style-type: none"> • Unknown—Gray—Indicates no severity level is specified. • Debug/Info/Notice—Green—Indicates conditions that are not errors but are of interest or might warrant special handling. • Warning—Yellow—Indicates conditions that warrant monitoring. • Error—Blue—Indicates standard error conditions that generally have less serious consequences than errors in the emergency, alert, and critical levels. • Critical—Pink—Indicates critical conditions, such as hard-drive errors. • Alert—Orange—Indicates conditions that require immediate correction, such as a corrupted system database. • Emergency—Red—Indicates system panic or other conditions that cause the switch to stop functioning. 	A severity level indicates how seriously the triggering event affects switch functions. When you configure a location for logging a facility, you also specify a severity level for the facility. Only messages from the facility that are rated at that level or higher are logged to the specified file.
Event ID	<p>Displays a code that uniquely identifies the message.</p> <p>The prefix on each code identifies the message source, and the rest of the code indicates the specific event or error.</p>	<p>The event ID begins with a prefix that indicates the generating software process.</p> <p>Some processes on a switch do not use codes. This field might be blank in a message generated from such a process.</p> <p>An event can belong to one of the following type categories:</p> <ul style="list-style-type: none"> • Error—Indicates an error or failure condition that might require corrective action. • Event—Indicates a condition or occurrence that does not generally require corrective action.
Event Description	Displays a more detailed explanation of the message.	
Time	Displays the time at which the message was logged.	

Release History Table

Release	Description
14.1X53	Starting in Junos OS Release 14.1X53, a Raw Report can be generated from the log messages being loaded in the Events Detail table.
14.1X53	Starting in Junos OS Release 14.1X53, a Formatted Report can be generated from event log messages being loaded in an Events Detail table.

Related Documentation

- [Checking Active Alarms with the J-Web Interface on page 196](#)
- [Understanding Alarm Types and Severity Levels on EX Series Switches on page 193](#)

Troubleshooting Switch Components

- [Troubleshooting PoE Voltage Injection Failure in EX2300, EX3400, or EX4300 Switch Models with PoE Capability on page 203](#)
- [Troubleshooting Storage Issues While Upgrading Junos OS in EX2300 and EX3400 Switches on page 203](#)
- [Troubleshooting Temperature Alarms in EX Series Switches on page 205](#)

Troubleshooting PoE Voltage Injection Failure in EX2300, EX3400, or EX4300 Switch Models with PoE Capability

Problem **Description:** Devices that draw power from EX2300, EX3400, or EX4300 switch models with Power over Ethernet (PoE) capability do not get power from those switches. The problem persists after rebooting the switches or upgrading to the latest version of Junos OS.

Environment: EX2300, EX3400, or EX4300 switch models with PoE capability are connected to EX2200, EX3200, or EX4200 switch models with PoE capability by using RJ-45 network ports.

Solution When you connect EX2300, EX3400, or EX4300 switch models with PoE capability to EX2200, EX3200, or EX4200 switch models with PoE capability by using RJ-45 network ports, disable PoE on all the RJ-45 network ports used to connect the switches using the command:

```
user@device> set poe interface interface-name disable
```

Related Documentation

- [Understanding PoE on EX Series Switches](#)

Troubleshooting Storage Issues While Upgrading Junos OS in EX2300 and EX3400 Switches

Problem **Description:** Upgrading Junos OS in EX2300 and EX3400 switches fails.

Symptoms: When you upgrade Junos OS in EX2300 and EX3400 switches, you get the error **not enough space to unpack *installation-pack-name***.

Cause There is not enough memory in the switch to install the upgrade installation package.

Solution If upgrading Junos OS in EX2300 and EX3400 switches fails due to the lack of memory in the switch:

1. Perform a system storage cleanup and delete unwanted files in the system storage by using the command:

```
user@switch> request system storage cleanup
```



NOTE:

You can get the list of files that this command deletes by using the command:

```
user@switch> request system storage cleanup dry-run
```

This command does not delete files in the *root* folder; it deletes files in the folders *jail*, *log*, and *tmp* only.

2. If any directory is taking up a lot of memory, delete unwanted files in that directory. Check the memory utilization by using the command:

```
user@switch> show system storage
```

3. Delete non-recovery snapshots.

- If Junos OS 15.1X53D56 or later is installed in your switch:

- a. Delete non-recovery snapshots by using the command:

```
user@switch> request system software add software-image-name force
```

- If a version of Junos OS released earlier than Junos OS 15.1X53D56 is installed in your switch:

- a. Check for non-recovery snapshots by using the command:

```
user@switch> show system snapshot
```



NOTE: Snapshot names are not completed automatically in the CLI; you must enter the snapshot name.

Delete non-recovery snapshots by using the command:

```
user@switch> request system snapshot delete snapshot-name
```

Related Documentation • [Understanding Software Installation on EX Series Switches](#)

Troubleshooting Temperature Alarms in EX Series Switches

Problem **Description:** EX Series switches generate a temperature alarm **FPC 0 EX-PFE1 Temp Too Hot**.

Cause Temperature sensors in the chassis monitor the temperature of the chassis. The switch raises an alarm if a fan fails or if the temperature of the chassis exceeds permissible levels.

Solution When the switch raises a temperature alarm such as the **FPC 0 EX-PFE1 Temp Too Hot** alarm, use the **show chassis environment** and the **show chassis temperature-thresholds** commands to identify the condition that triggered the alarm.



CAUTION: To prevent the switch from overheating, do not operate it in an area that exceeds the maximum recommended ambient temperature of 104°F (40°C). To prevent airflow restriction, allow at least 6 inches (15.2 cm) of clearance around the ventilation openings.

1. Connect to the switch by using Telnet and issue the **show chassis environment** command. This command displays environmental information about the switch chassis, including the temperature, and information about the fans, power supplies, and Routing Engines. Following is a sample output:

```
user@switch> show chassis environment
```

Class	Item	Status	Measurement
Temp	PEM 0	OK	40 degrees C / 104 degrees F
	PEM 1	OK	40 degrees C / 104 degrees F
	PEM 2	Absent	
	PEM 3	Absent	
Routing Engine	Routing Engine 0	OK	37 degrees C / 98 degrees F
	Routing Engine 0 CPU	OK	35 degrees C / 95 degrees F
	Routing Engine 1	Absent	
	Routing Engine 1 CPU	Absent	
CB 0	Intake	OK	36 degrees C / 96 degrees F
	Exhaust A	OK	34 degrees C / 93 degrees F
	Exhaust B	OK	40 degrees C / 104 degrees F
	ACBC	OK	39 degrees C / 102 degrees F
	XF A	OK	46 degrees C / 114 degrees F
	XF B	OK	45 degrees C / 113 degrees F
	CB 1 Intake	Absent	
	CB 1 Exhaust A	Absent	

CB 1 Exhaust B	Absent	
CB 1 ACBC	Absent	
CB 1 XF A	Absent	
CB 1 XF B	Absent	
FPC 3 Intake	OK	48 degrees C / 118 degrees F
FPC 3 Exhaust A	OK	46 degrees C / 114 degrees F
FPC 3 Exhaust B	OK	51 degrees C / 123 degrees F
FPC 3 XL TSen	OK	67 degrees C / 152 degrees F
FPC 3 XL Chip	OK	58 degrees C / 136 degrees F
FPC 3 XL_XR0 TSen	OK	67 degrees C / 152 degrees F
FPC 3 XL_XR0 Chip	OK	51 degrees C / 123 degrees F
FPC 3 XL_XR1 TSen	OK	67 degrees C / 152 degrees F
FPC 3 XL_XR1 Chip	OK	63 degrees C / 145 degrees F
FPC 3 XQ TSen	OK	67 degrees C / 152 degrees F
FPC 3 XQ Chip	OK	63 degrees C / 145 degrees F
FPC 3 XQ_XR0 TSen	OK	67 degrees C / 152 degrees F
FPC 3 XQ_XR0 Chip	OK	68 degrees C / 154 degrees F
FPC 3 XM TSen	OK	67 degrees C / 152 degrees F
FPC 3 XM Chip	OK	76 degrees C / 168 degrees F
FPC 3 XF TSen	OK	67 degrees C / 152 degrees F
FPC 3 XF Chip	OK	75 degrees C / 167 degrees F
FPC 3 PLX PCIe Switch TSe	OK	51 degrees C / 123 degrees F
FPC 3 PLX PCIe Switch Chi	OK	54 degrees C / 129 degrees F
FPC 3 Aloha FPGA 0 TSen	OK	51 degrees C / 123 degrees F
FPC 3 Aloha FPGA 0 Chip	OK	70 degrees C / 158 degrees F
FPC 3 Aloha FPGA 1 TSen	OK	51 degrees C / 123 degrees F
FPC 3 Aloha FPGA 1 Chip	OK	75 degrees C / 167 degrees F
FPC 5 Intake	Testing	
FPC 5 Exhaust A	Testing	
FPC 5 Exhaust B	Testing	
Fans Top Rear Fan	OK	Spinning at intermediate-speed
Bottom Rear Fan	OK	Spinning at intermediate-speed
Top Middle Fan	OK	Spinning at intermediate-speed
Bottom Middle Fan	OK	Spinning at intermediate-speed
Top Front Fan	OK	Spinning at intermediate-speed
Bottom Front Fan	OK	Spinning at intermediate-speed

Table 59 on page 206 lists the output fields for the **show chassis environment** command. Output fields are listed in the approximate order in which they appear.

Table 59: show chassis environment Output Fields

Field Name	Field Description
Class	Information about the category or class of chassis component: <ul style="list-style-type: none"> • Temp: Temperature of air flowing through the chassis in degrees Celsius (°C) and degrees Fahrenheit (°F). • Fans: Information about the status of fans and blowers.
Item	Information about the chassis components: Flexible PIC Concentrators (FPCs)—that is, the line cards—, Control Boards (CBs), Routing Engines (REs), Power Entry Modules (PEMs)—that is, the power supplies.

Table 59: show chassis environment Output Fields (*continued*)

Field Name	Field Description
Status	Status of the specified chassis component. For example, if Class is Fans , the fan status can be: <ul style="list-style-type: none"> • OK: The fans are operational. • Testing: The fans are being tested during initial power-on. • Failed: The fans have failed or the fans are not spinning. • Absent: The fan tray is not installed.
Measurement	Depends on the Class. For example, if Class is Temp , indicates the temperature in degrees Celsius (°C) and degrees Fahrenheit (°F). If the Class is Fans , indicates actual fan RPM.

2. Issue the command **show chassis temperature-thresholds**. This command displays the chassis temperature threshold settings.

```

user@ host> show chassis temperature-thresholds

```

Item	Fan speed (degrees C)		Yellow alarm (degrees C)		Red alarm (degrees C)		Fire Shutdown (degrees C)
	Normal	High	Normal	Bad fan	Normal	Bad fan	Normal
Chassis default	48	54	65	55	80	65	100
Routing Engine 0	70	80	95	95	110	110	112
FPC 3	55	60	75	65	105	80	110
FPC 5	55	60	75	65	90	80	95

[Table 60 on page 207](#) lists the output fields for the **show chassis temperature-thresholds** command. Output fields are listed in the approximate order in which they appear.

Table 60: show chassis temperature-thresholds Output Fields

Field name	Field Description
Item	Chassis component. You can configure for the threshold information for components such as the chassis, the Routing Engines, and FPC for each slot in each FRU to display in the output. By default, information is displayed only for the chassis and the Routing Engines.
Fan speed	Temperature thresholds, in degrees Celsius, for the fans to operate at normal and at high speed. <ul style="list-style-type: none"> • Normal—The temperature threshold at which the fans operate at normal speed and when all the fans are present and functioning normally. • High—The temperature threshold at which the fans operate at high speed or when a fan has failed or is missing. <p>NOTE: An alarm is not triggered until the temperature exceeds the threshold settings for a yellow alarm or a red alarm.</p>
Yellow alarm	Temperature threshold, in degrees Celsius, that trigger a yellow alarm. <ul style="list-style-type: none"> • Normal—The temperature threshold that must be exceeded on the component to trigger a yellow alarm when the fans are running at full speed. • Bad fan—The temperature threshold that must be exceeded on the component to trigger a yellow alarm when one or more fans have failed or are missing.

Table 60: show chassis temperature-thresholds Output Fields (*continued*)

Field name	Field Description
Red alarm	<p>Temperature threshold, in degrees Celsius, that trigger a red alarm.</p> <ul style="list-style-type: none"> • Normal—The temperature threshold that must be exceeded on the component to trigger a red alarm when the fans are running at full speed. • Bad fan—The temperature threshold that must be exceeded on the component to trigger a red alarm when one or more fans have failed or are missing.
Fire Shutdown	Temperature threshold, in degrees Celsius, for the switch to shut down.

When a temperature alarm is triggered, you can identify the condition that triggered it by running the **show chassis environment** command to display the chassis temperature values for each component and comparing those with the temperature threshold values, which you can display by running the **show chassis temperature-thresholds** command.

For example, for **FPC 3**:

- If the temperature of **FPC 3** exceeds 55° C, the output indicates that the fans are operating at a high speed (no alarm is triggered).
- If the temperature of **FPC 3** exceeds 65° C, a yellow alarm is triggered to indicate that one or more fans have failed.
- If the temperature of **FPC 3** exceeds 75° C, a yellow alarm is triggered to indicate that the temperature threshold limit is exceeded.
- If the temperature of **FPC 3** exceeds 80° C, a red alarm is triggered to indicate that one or more fans have failed.
- If the temperature of **FPC 3** exceeds 105° C, a red alarm is triggered to indicate that the temperature threshold limit is exceeded.
- If the temperature of **FPC 3** exceeds 110° C, the switch is powered off.

Table 61 on page 208 lists the possible causes for the switch to generate a temperature alarm and the respective remedies.

Table 61: Causes and Remedies for Temperature Alarms

Cause	Remedy
Ambient temperature is above threshold temperature.	Ensure that the ambient temperature is within the threshold temperature limit. See “Environmental Requirements and Specifications for EX Series Switches” on page 55.
Fan module or fan tray has failed.	<ul style="list-style-type: none"> • Check the fan. • Replace the faulty fan module or fan tray. • If the above two checks show no problems, open a support case using the Case Manager link at http://www.juniper.net/support/ or call 1-888-314-5822 (toll-free within the United States and Canada) or 1-408-745-9500 (from outside the United States).

Table 61: Causes and Remedies for Temperature Alarms (*continued*)

Cause	Remedy
Restricted airflow through the switch due to insufficient clearance around the installed switch.	<p data-bbox="688 384 1427 468">Ensure that there is sufficient clearance around the installed switch. See the following topics to understand the clearance requirements of various EX Series switches.</p> <ul style="list-style-type: none"> <li data-bbox="688 489 1427 552">• <i>Clearance Requirements for Airflow and Hardware Maintenance for EX2200 Switches</i> <li data-bbox="688 552 1427 615">• Clearance Requirements for Airflow and Hardware Maintenance for EX2300 Switches on page 64 <li data-bbox="688 615 1427 678">• <i>Clearance Requirements for Airflow and Hardware Maintenance for EX3200 Switches</i> <li data-bbox="688 678 1427 741">• <i>Clearance Requirements for Airflow and Hardware Maintenance for EX3300 Switches</i> <li data-bbox="688 741 1427 804">• <i>Clearance Requirements for Airflow and Hardware Maintenance for EX3400 Switches</i> <li data-bbox="688 804 1427 867">• <i>Clearance Requirements for Airflow and Hardware Maintenance for EX4200 Switches</i> <li data-bbox="688 867 1427 930">• <i>Clearance Requirements for Airflow and Hardware Maintenance for EX4300 Switches</i> <li data-bbox="688 930 1427 993">• <i>Clearance Requirements for Airflow and Hardware Maintenance for EX4500 Switches</i> <li data-bbox="688 993 1427 1056">• <i>Clearance Requirements for Airflow and Hardware Maintenance for EX4550 Switches</i> <li data-bbox="688 1056 1427 1119">• <i>Clearance Requirements for Airflow and Hardware Maintenance for an EX6210 Switch</i> <li data-bbox="688 1119 1427 1182">• <i>Clearance Requirements for Airflow and Hardware Maintenance for an EX8208 Switch</i> <li data-bbox="688 1182 1427 1245">• <i>Clearance Requirements for Airflow and Hardware Maintenance for an EX8216 Switch</i> <li data-bbox="688 1245 1427 1308">• <i>Clearance Requirements for Airflow and Hardware Maintenance for an EX9204 Switch</i> <li data-bbox="688 1308 1427 1371">• <i>Clearance Requirements for Airflow and Hardware Maintenance for an EX9208 Switch</i> <li data-bbox="688 1371 1427 1400">• <i>Clearance Requirements for Airflow and Hardware Maintenance for an EX9214 Switch</i>

Related Documentation • [Understanding Alarm Types and Severity Levels on EX Series Switches on page 193](#)

PART 6

Safety and Compliance Information

- General Safety Guidelines and Warnings on page 213
- Fire Safety Requirements on page 219
- Installation Safety Guidelines and Warnings on page 221
- Radiation and Laser Safety Guidelines and Warnings on page 231
- Maintenance and Operational Safety Warnings on page 235
- Electrical Safety Guidelines and Warnings on page 241
- Agency Approvals and Compliance Statements on page 257

CHAPTER 21

General Safety Guidelines and Warnings

- [General Safety Guidelines and Warnings on page 213](#)
- [Definitions of Safety Warning Levels on page 214](#)
- [Qualified Personnel Warning on page 216](#)
- [Warning Statement for Norway and Sweden on page 217](#)

General Safety Guidelines and Warnings

The following guidelines help ensure your safety and protect the device from damage. The list of guidelines might not address all potentially hazardous situations in your working environment, so be alert and exercise good judgment at all times.

- Perform only the procedures explicitly described in the hardware documentation for this device. Make sure that only authorized service personnel perform other system services.
- Keep the area around the device clear and free from dust before, during, and after installation.
- Keep tools away from areas where people could trip over them while walking.
- Do not wear loose clothing or jewelry, such as rings, bracelets, or chains, which could become caught in the device.
- Wear safety glasses if you are working under any conditions that could be hazardous to your eyes.
- Do not perform any actions that create a potential hazard to people or make the equipment unsafe.
- Never attempt to lift an object that is too heavy for one person to handle.
- Never install or manipulate wiring during electrical storms.
- Never install electrical jacks in wet locations unless the jacks are specifically designed for wet environments.
- Operate the device only when it is properly grounded.
- Ensure that the separate protective earthing terminal provided on this device is permanently connected to earth.
- Replace fuses only with fuses of the same type and rating.

- Do not open or remove chassis covers or sheet-metal parts unless instructions are provided in the hardware documentation for this device. Such an action could cause severe electrical shock.
- Do not push or force any objects through any opening in the chassis frame. Such an action could result in electrical shock or fire.
- Avoid spilling liquid onto the chassis or onto any device component. Such an action could cause electrical shock or damage the device.
- Avoid touching uninsulated electrical wires or terminals that have not been disconnected from their power source. Such an action could cause electrical shock.
- Always ensure that all modules, power supplies, and cover panels are fully inserted and that the installation screws are fully tightened.

Related Documentation

- [AC Power Electrical Safety Guidelines on page 244](#)
- [General Electrical Safety Guidelines and Warnings on page 241](#)
- [Maintenance and Operational Safety Guidelines and Warnings on page 235](#)
- [Installation Instructions Warning on page 221](#)
- [Grounded Equipment Warning on page 228](#)

Definitions of Safety Warning Levels

The documentation uses the following levels of safety warnings (there are two *Warning* formats):



NOTE: You might find this information helpful in a particular situation, or you might overlook this important information if it was not highlighted in a Note.



CAUTION: You need to observe the specified guidelines to prevent minor injury or discomfort to you or severe damage to the device.



WARNING: This symbol alerts you to the risk of personal injury from a laser.



WARNING: This symbol means danger. You are in a situation that could cause bodily injury. Before you work on any equipment, be aware of the hazards involved with electrical circuitry and be familiar with standard practices for preventing accidents.

Waarschuwing Dit waarschuwingssymbool betekent gevaar. U verkeert in een situatie die lichamelijk letsel kan veroorzaken. Voordat u aan enige

apparatuur gaat werken, dient u zich bewust te zijn van de bij elektrische schakelingen betrokken risico's en dient u op de hoogte te zijn van standaard maatregelen om ongelukken te voorkomen.

Varoitus Tämä varoitusmerkki merkitsee vaaraa. Olet tilanteessa, joka voi johtaa ruumiinvammaan. Ennen kuin työskentelet minkään laitteiston parissa, ota selvää sähkökytkentöihin liittyvistä vaaroista ja tavanomaisista onnettomuuksien ehkäisykeinoista.

Attention Ce symbole d'avertissement indique un danger. Vous vous trouvez dans une situation pouvant causer des blessures ou des dommages corporels. Avant de travailler sur un équipement, soyez conscient des dangers posés par les circuits électriques et familiarisez-vous avec les procédures couramment utilisées pour éviter les accidents.

Warnung Dieses Warnsymbol bedeutet Gefahr. Sie befinden sich in einer Situation, die zu einer Körperverletzung führen könnte. Bevor Sie mit der Arbeit an irgendeinem Gerät beginnen, seien Sie sich der mit elektrischen Stromkreisen verbundenen Gefahren und der Standardpraktiken zur Vermeidung von Unfällen bewußt.

Avvertenza Questo simbolo di avvertenza indica un pericolo. La situazione potrebbe causare infortuni alle persone. Prima di lavorare su qualsiasi apparecchiatura, occorre conoscere i pericoli relativi ai circuiti elettrici ed essere al corrente delle pratiche standard per la prevenzione di incidenti.

Advarsel Dette varselsymbolet betyr fare. Du befinner deg i en situasjon som kan føre til personskade. Før du utfører arbeid på utstyr, må du være oppmerksom på de faremomentene som elektriske kretser innebærer, samt gjøre deg kjent med vanlig praksis når det gjelder å unngå ulykker.

Aviso Este símbolo de aviso indica perigo. Encontra-se numa situação que lhe poderá causar danos físicos. Antes de começar a trabalhar com qualquer equipamento, familiarize-se com os perigos relacionados com circuitos eléctricos, e com quaisquer práticas comuns que possam prevenir possíveis acidentes.

¡Atención! Este símbolo de aviso significa peligro. Existe riesgo para su integridad física. Antes de manipular cualquier equipo, considerar los riesgos que entraña la corriente eléctrica y familiarizarse con los procedimientos estándar de prevención de accidentes.

Varning! Denna varningsymbol signalerar fara. Du befinner dig i en situation som kan leda till personskada. Innan du utför arbete på någon utrustning måste du vara medveten om farorna med elkretsar och känna till vanligt förfarande för att förebygga skador.

Related Documentation • [General Safety Guidelines and Warnings on page 213](#)

- [Installation Instructions Warning on page 221](#)
- [Maintenance and Operational Safety Guidelines and Warnings on page 235](#)
- [Grounded Equipment Warning on page 228](#)
- [Laser and LED Safety Guidelines and Warnings on page 231](#)
- [Laser and LED Safety Guidelines and Warnings for the ACX5000 Router](#)
- [Warning Statement for Norway and Sweden on page 217](#)

Qualified Personnel Warning



WARNING: Only trained and qualified personnel should install or replace the device.

Waarschuwing Installatie en reparaties mogen uitsluitend door getraind en bevoegd personeel uitgevoerd worden.

Varoitus Ainoastaan koulutettu ja pätevä henkilökunta saa asentaa tai vaihtaa tämän laitteen.

Attention Tout installation ou remplacement de l'appareil doit être réalisé par du personnel qualifié et compétent.

Warnung Gerät nur von geschultem, qualifiziertem Personal installieren oder auswechseln lassen.

Avvertenza Solo personale addestrato e qualificato deve essere autorizzato ad installare o sostituire questo apparecchio.

Advarsel Kun kvalifisert personell med riktig opplæring bør montere eller bytte ut dette utstyret.

Aviso Este equipamento deverá ser instalado ou substituído apenas por pessoal devidamente treinado e qualificado.

¡Atención! Estos equipos deben ser instalados y reemplazados exclusivamente por personal técnico adecuadamente preparado y capacitado.

Varning! Denna utrustning ska endast installeras och bytas ut av utbildad och kvalificerad personal.

Related Documentation

- [General Safety Guidelines and Warnings on page 213](#)
- [General Electrical Safety Guidelines and Warnings on page 241](#)
- [AC Power Electrical Safety Guidelines on page 244](#)
- [DC Power Electrical Safety Guidelines for Switches on page 246](#)

Warning Statement for Norway and Sweden



.....
WARNING: The equipment must be connected to an earthed mains socket-outlet.

Advarsel Apparatet skal kobles til en jordet stikkontakt.

Varning! Apparaten skall anslutas till jordat nätuttag.
.....

- Related Documentation**
- [General Safety Guidelines and Warnings on page 213](#)

CHAPTER 22

Fire Safety Requirements

- [Fire Safety Requirements on page 219](#)

Fire Safety Requirements

In the event of a fire emergency, the safety of people is the primary concern. You should establish procedures for protecting people in the event of a fire emergency, provide safety training, and properly provision fire-control equipment and fire extinguishers.

In addition, you should establish procedures to protect your equipment in the event of a fire emergency. Juniper Networks products should be installed in an environment suitable for electronic equipment. We recommend that fire suppression equipment be available in the event of a fire in the vicinity of the equipment and that all local fire, safety, and electrical codes and ordinances be observed when you install and operate your equipment.

Fire Suppression

In the event of an electrical hazard or an electrical fire, you should first turn power off to the equipment at the source. Then use a Type C fire extinguisher, which uses noncorrosive fire retardants, to extinguish the fire.

Fire Suppression Equipment

Type C fire extinguishers, which use noncorrosive fire retardants such as carbon dioxide and Halotron™, are most effective for suppressing electrical fires. Type C fire extinguishers displace oxygen from the point of combustion to eliminate the fire. For extinguishing fire on or around equipment that draws air from the environment for cooling, you should use this type of inert oxygen displacement extinguisher instead of an extinguisher that leaves residues on equipment.

Do not use multipurpose Type ABC chemical fire extinguishers (dry chemical fire extinguishers). The primary ingredient in these fire extinguishers is monoammonium phosphate, which is very sticky and difficult to clean. In addition, in the presence of minute amounts of moisture, monoammonium phosphate can become highly corrosive and corrodes most metals.

Any equipment in a room in which a chemical fire extinguisher has been discharged is subject to premature failure and unreliable operation. The equipment is considered to be irreparably damaged.



.....

NOTE: To keep warranties effective, do not use a dry chemical fire extinguisher to control a fire at or near a Juniper Networks device. If a dry chemical fire extinguisher is used, the unit is no longer eligible for coverage under a service agreement.

.....

We recommend that you dispose of any irreparably damaged equipment in an environmentally responsible manner.

**Related
Documentation**

- [General Safety Guidelines and Warnings on page 213](#)
- [General Electrical Safety Guidelines and Warnings on page 241](#)
- [Action to Take After an Electrical Accident on page 242](#)

Installation Safety Guidelines and Warnings

- Installation Instructions Warning on page 221
- Chassis Lifting Guidelines on page 222
- Restricted Access Warning on page 222
- Ramp Warning on page 224
- Rack-Mounting and Cabinet-Mounting Warnings on page 224
- Wall-Mounting Warnings for EX2300 Switches on page 228
- Grounded Equipment Warning on page 228

Installation Instructions Warning



WARNING: Read the installation instructions before you connect the device to a power source.

Waarschuwing Raadpleeg de installatie-aanwijzingen voordat u het systeem met de voeding verbindt.

Varoitus Lue asennusohjeet ennen järjestelmän yhdistämistä virtalähteeseen.

Attention Avant de brancher le système sur la source d'alimentation, consulter les directives d'installation.

Warnung Lesen Sie die Installationsanweisungen, bevor Sie das System an die Stromquelle anschließen.

Avvertenza Consultare le istruzioni di installazione prima di collegare il sistema all'alimentatore.

Advarsel Les installasjonsinstruksjonene før systemet kobles til strømkilden.

Aviso Leia as instruções de instalação antes de ligar o sistema à sua fonte de energia.

¡Atención! Ver las instrucciones de instalación antes de conectar el sistema a la red de alimentación.

Warning! Läs installationsanvisningarna innan du kopplar systemet till dess strömförsörjningsenhet.

- Related Documentation**
- [General Safety Guidelines and Warnings on page 213](#)
 - [Laser and LED Safety Guidelines and Warnings on page 231](#)
 - [Laser and LED Safety Guidelines and Warnings for the ACX5000 Router](#)
 - [Grounded Equipment Warning on page 228](#)

Chassis Lifting Guidelines

- Before moving the device to a site, ensure that the site meets the power, environmental, and clearance requirements.
- Before lifting or moving the device, disconnect all external cables and wires.
- As when lifting any heavy object, ensure that most of the weight is borne by your legs rather than your back. Keep your knees bent and your back relatively straight. Do not twist your body as you lift. Balance the load evenly and be sure that your footing is firm.
- Use the following lifting guidelines to lift routing devices and components:
 - Up to 39.7 lb (18 kg): One person.
 - 39.7 lb (18 kg) to 70.5 lb (32 kg): Two or more people.
 - 70.5 lb (32 kg) to 121.2 lb (55 kg): Three or more people.
 - Above 121.2 lbs (55 kg): Material handling systems (such as levers, slings, lifts and so on) must be used. When this is not practical, specially trained persons or systems must be used (riggers or movers).

- Related Documentation**
- [General Safety Guidelines and Warnings on page 213](#)
 - [Installation Instructions Warning on page 221](#)

Restricted Access Warning



WARNING: This unit is intended for installation in restricted access areas. A restricted access area is an area to which access can be gained only by service personnel through the use of a special tool, lock and key, or other means of security, and which is controlled by the authority responsible for the location.

Waarschuwing Dit toestel is bedoeld voor installatie op plaatsen met beperkte toegang. Een plaats met beperkte toegang is een plaats waar toegang slechts door servicepersoneel verkregen kan worden door middel van een speciaal instrument, een slot en sleutel, of een ander veiligheidsmiddel, en welke

beheerd wordt door de overheidsinstantie die verantwoordelijk is voor de locatie.

Varoitus Tämä laite on tarkoitettu asennettavaksi paikkaan, johon pääsy on rajoitettua. Paikka, johon pääsy on rajoitettua, tarkoittaa paikkaa, johon vain huoltohenkilöstö pääsee jonkin erikoistyökalun, lukkoon sopivan avaimen tai jonkin muun turvalaitteen avulla ja joka on paikasta vastuussa olevien toimivaltaisten henkilöiden valvoma.

Attention Cet appareil est à installer dans des zones d'accès réservé. Ces dernières sont des zones auxquelles seul le personnel de service peut accéder en utilisant un outil spécial, un mécanisme de verrouillage et une clé, ou tout autre moyen de sécurité. L'accès aux zones de sécurité est sous le contrôle de l'autorité responsable de l'emplacement.

Warnung Diese Einheit ist zur Installation in Bereichen mit beschränktem Zutritt vorgesehen. Ein Bereich mit beschränktem Zutritt ist ein Bereich, zu dem nur Wartungspersonal mit einem Spezialwerkzeugs, Schloß und Schlüssel oder anderer Sicherheitsvorkehrungen Zugang hat, und der von dem für die Anlage zuständigen Gremium kontrolliert wird.

Avvertenza Questa unità deve essere installata in un'area ad accesso limitato. Un'area ad accesso limitato è un'area accessibile solo a personale di assistenza tramite un'attrezzo speciale, lucchetto, o altri dispositivi di sicurezza, ed è controllata dall'autorità responsabile della zona.

Advarsel Denne enheten er laget for installasjon i områder med begrenset adgang. Et område med begrenset adgang gir kun adgang til servicepersonale som bruker et spesielt verktøy, lås og nøkkel, eller en annen sikkerhetsanordning, og det kontrolleres av den autoriteten som er ansvarlig for området.

Aviso Esta unidade foi concebida para instalação em áreas de acesso restrito. Uma área de acesso restrito é uma área à qual apenas tem acesso o pessoal de serviço autorizado, que possua uma ferramenta, chave e fechadura especial, ou qualquer outra forma de segurança. Esta área é controlada pela autoridade responsável pelo local.

¡Atención! Esta unidad ha sido diseñada para instalarse en áreas de acceso restringido. Área de acceso restringido significa un área a la que solamente tiene acceso el personal de servicio mediante la utilización de una herramienta especial, cerradura con llave, o algún otro medio de seguridad, y que está bajo el control de la autoridad responsable del local.

Varning! Denna enhet är avsedd för installation i områden med begränsat tillträde. Ett område med begränsat tillträde får endast tillträdas av servicepersonal med ett speciellt verktyg, lås och nyckel, eller annan säkerhetsanordning, och kontrolleras av den auktoritet som ansvarar för området.

- Related Documentation**
- [General Safety Guidelines and Warnings on page 213](#)
 - [General Electrical Safety Guidelines and Warnings on page 241](#)
 - [Installation Instructions Warning on page 221](#)
 - [Grounded Equipment Warning on page 228](#)

Ramp Warning



WARNING: When installing the device, do not use a ramp inclined at more than 10 degrees.

Waarschuwing Gebruik een oprijplaat niet onder een hoek van meer dan 10 graden.

Varoitus Älä käytä sellaista kaltevaa pintaa, jonka kaltevuus ylittää 10 astetta.

Attention Ne pas utiliser une rampe dont l'inclinaison est supérieure à 10 degrés.

Warnung Keine Rampen mit einer Neigung von mehr als 10 Grad verwenden.

Avvertenza Non usare una rampa con pendenza superiore a 10 gradi.

Advarsel Bruk aldri en rampe som heller mer enn 10 grader.

Aviso Não utilize uma rampa com uma inclinação superior a 10 graus.

¡Atención! No usar una rampa inclinada más de 10 grados

Varning! Använd inte ramp med en lutning på mer än 10 grader.

- Related Documentation**
- [General Safety Guidelines and Warnings on page 213](#)
 - [Installation Instructions Warning on page 221](#)
 - [Grounded Equipment Warning on page 228](#)

Rack-Mounting and Cabinet-Mounting Warnings

Ensure that the rack or cabinet in which the device is installed is evenly and securely supported. Uneven mechanical loading could lead to a hazardous condition.



WARNING: To prevent bodily injury when mounting or servicing the device in a rack, take the following precautions to ensure that the system remains stable. The following directives help maintain your safety:

- The device must be installed in a rack that is secured to the building structure.
- The device should be mounted at the bottom of the rack if it is the only unit in the rack.
- When mounting the device on a partially filled rack, load the rack from the bottom to the top with the heaviest component at the bottom of the rack.
- If the rack is provided with stabilizing equipment, install the stabilizers before mounting or servicing the device in the rack.

Waarschuwing Om lichamelijk letsel te voorkomen wanneer u dit toestel in een rek monteert of het daar een servicebeurt geeft, moet u speciale voorzorgsmaatregelen nemen om ervoor te zorgen dat het toestel stabiel blijft. De onderstaande richtlijnen worden verstrekt om uw veiligheid te verzekeren:

- De Juniper Networks switch moet in een stellage worden geïnstalleerd die aan een bouwsel is verankerd.
- Dit toestel dient onderaan in het rek gemonteerd te worden als het toestel het enige in het rek is.
- Wanneer u dit toestel in een gedeeltelijk gevuld rek monteert, dient u het rek van onderen naar boven te laden met het zwaarste onderdeel onderaan in het rek.
- Als het rek voorzien is van stabiliseringshulpmiddelen, dient u de stabilisatoren te monteren voordat u het toestel in het rek monteert of het daar een servicebeurt geeft.

Varoitus Kun laite asetetaan telineeseen tai huolletaan sen ollessa telineessä, on noudatettava erityisiä varotoimia järjestelmän vakavuuden säilyttämiseksi, jotta vältetään loukkaantumiselta. Noudata seuraavia turvallisuusohjeita:

- Juniper Networks switch on asennettava telineeseen, joka on kiinnitetty rakennukseen.
- Jos telineessä ei ole muita laitteita, aseta laite telineen alaosaan.
- Jos laite asetetaan osaksi täytettyyn telineeseen, aloita kuormittaminen sen alaosasta kaikkein raskaimmalla esineellä ja siirry sitten sen yläosaan.
- Jos telinettä varten on vakaimet, asenna ne ennen laitteen asettamista telineeseen tai sen huoltamista siinä.

Attention Pour éviter toute blessure corporelle pendant les opérations de montage ou de réparation de cette unité en casier, il convient de prendre des précautions spéciales afin de maintenir la stabilité du système. Les directives ci-dessous sont destinées à assurer la protection du personnel:

- Le rack sur lequel est monté le Juniper Networks switch doit être fixé à la structure du bâtiment.
- Si cette unité constitue la seule unité montée en casier, elle doit être placée dans le bas.
- Si cette unité est montée dans un casier partiellement rempli, charger le casier de bas en haut en plaçant l'élément le plus lourd dans le bas.
- Si le casier est équipé de dispositifs stabilisateurs, installer les stabilisateurs avant de monter ou de réparer l'unité en casier.

Warnung Zur Vermeidung von Körperverletzung beim Anbringen oder Warten dieser Einheit in einem Gestell müssen Sie besondere Vorkehrungen treffen, um sicherzustellen, daß das System stabil bleibt. Die folgenden Richtlinien sollen zur Gewährleistung Ihrer Sicherheit dienen:

- Der Juniper Networks switch muß in einem Gestell installiert werden, das in der Gebäudestruktur verankert ist.
- Wenn diese Einheit die einzige im Gestell ist, sollte sie unten im Gestell angebracht werden.
- Bei Anbringung dieser Einheit in einem zum Teil gefüllten Gestell ist das Gestell von unten nach oben zu laden, wobei das schwerste Bauteil unten im Gestell anzubringen ist.
- Wird das Gestell mit Stabilisierungszubehör geliefert, sind zuerst die Stabilisatoren zu installieren, bevor Sie die Einheit im Gestell anbringen oder sie warten.

Avvertenza Per evitare infortuni fisici durante il montaggio o la manutenzione di questa unità in un supporto, occorre osservare speciali precauzioni per garantire che il sistema rimanga stabile. Le seguenti direttive vengono fornite per garantire la sicurezza personale:

- Il Juniper Networks switch deve essere installato in un telaio, il quale deve essere fissato alla struttura dell'edificio.
- Questa unità deve venire montata sul fondo del supporto, se si tratta dell'unica unità da montare nel supporto.
- Quando questa unità viene montata in un supporto parzialmente pieno, caricare il supporto dal basso all'alto, con il componente più pesante sistemato sul fondo del supporto.
- Se il supporto è dotato di dispositivi stabilizzanti, installare tali dispositivi prima di montare o di procedere alla manutenzione dell'unità nel supporto.

Advarsel Unngå fysiske skader under montering eller reparasjonsarbeid på denne enheten når den befinner seg i et kabinett. Vær nøye med at systemet er stabilt. Følgende retningslinjer er gitt for å verne om sikkerheten:

- Juniper Networks switch må installeres i et stativ som er forankret til bygningsstrukturen.
- Denne enheten bør monteres nederst i kabinettet hvis dette er den eneste enheten i kabinettet.
- Ved montering av denne enheten i et kabinett som er delvis fylt, skal kabinettet lastes fra bunnen og opp med den tyngste komponenten nederst i kabinettet.
- Hvis kabinettet er utstyrt med stabiliseringsutstyr, skal stabilisatorene installeres før montering eller utføring av reparasjonsarbeid på enheten i kabinettet.

Aviso Para se prevenir contra danos corporais ao montar ou reparar esta unidade numa estante, deverá tomar precauções especiais para se certificar de que o sistema possui um suporte estável. As seguintes directrizes ajudá-lo-ão a efectuar o seu trabalho com segurança:

- O Juniper Networks switch deverá ser instalado numa prateleira fixa à estrutura do edifício.
- Esta unidade deverá ser montada na parte inferior da estante, caso seja esta a única unidade a ser montada.
- Ao montar esta unidade numa estante parcialmente ocupada, coloque os itens mais pesados na parte inferior da estante, arrumando-os de baixo para cima.
- Se a estante possuir um dispositivo de estabilização, instale-o antes de montar ou reparar a unidade.

¡Atención! Para evitar lesiones durante el montaje de este equipo sobre un bastidor, o posteriormente durante su mantenimiento, se debe poner mucho cuidado en que el sistema quede bien estable. Para garantizar su seguridad, proceda según las siguientes instrucciones:

- El Juniper Networks switch debe instalarse en un bastidor fijado a la estructura del edificio.
- Colocar el equipo en la parte inferior del bastidor, cuando sea la única unidad en el mismo.
- Cuando este equipo se vaya a instalar en un bastidor parcialmente ocupado, comenzar la instalación desde la parte inferior hacia la superior colocando el equipo más pesado en la parte inferior.
- Si el bastidor dispone de dispositivos estabilizadores, instalar éstos antes de montar o proceder al mantenimiento del equipo instalado en el bastidor.

Varning! För att undvika kroppsskada när du installerar eller utför underhållsarbete på denna enhet på en ställning måste du vidta särskilda

försiktighetsåtgärder för att försäkra dig om att systemet står stadigt. Följande riktlinjer ges för att trygga din säkerhet:

- Juniper Networks switch måste installeras i en ställning som är förankrad i byggnadens struktur.
- Om denna enhet är den enda enheten på ställningen skall den installeras längst ned på ställningen.
- Om denna enhet installeras på en delvis fylld ställning skall ställningen fyllas nedifrån och upp, med de tyngsta enheterna längst ned på ställningen.
- Om ställningen är försedd med stabiliseringsdon skall dessa monteras fast innan enheten installeras eller underhålls på ställningen.

Related Documentation

- [General Safety Guidelines and Warnings on page 213](#)
- [Installation Instructions Warning on page 221](#)
- [Grounded Equipment Warning on page 228](#)

Wall-Mounting Warnings for EX2300 Switches



WARNING: When mounting an EX2300 switch chassis on a wall, orient the front panel of the chassis to the right side.

Related Documentation

- [Mounting an EX2300 Switch on a Wall on page 118](#)

Grounded Equipment Warning



WARNING: The device is intended to be grounded. During normal use, ensure that you have connected earth ground to the chassis.

Waarschuwing Deze apparatuur hoort geaard te worden. Zorg dat de host-computer tijdens normaal gebruik met aarde is verbonden.

Varoitus Tämä laitteisto on tarkoitettu maadoitettavaksi. Varmista, että isäntälaitte on yhdistetty maahan normaalikäytön aikana.

Attention Cet équipement doit être relié à la terre. S'assurer que l'appareil hôte est relié à la terre lors de l'utilisation normale.

Warnung Dieses Gerät muß geerdet werden. Stellen Sie sicher, daß das Host-Gerät während des normalen Betriebs an Erde gelegt ist.

Avvertenza Questa apparecchiatura deve essere collegata a massa. Accertarsi che il dispositivo host sia collegato alla massa di terra durante il normale utilizzo.

Advarsel Dette utstyret skal jordes. Forviss deg om vertsterminalen er jordet ved normalt bruk.

Aviso Este equipamento deverá estar ligado à terra. Certifique-se que o host se encontra ligado à terra durante a sua utilização normal.

¡Atención! Este equipo debe conectarse a tierra. Asegurarse de que el equipo principal esté conectado a tierra durante el uso normal.

Varning! Denna utrustning är avsedd att jordas. Se till att värdenheten är jordad vid normal användning.

**Related
Documentation**

- [General Safety Guidelines and Warnings on page 213](#)
- [AC Power Electrical Safety Guidelines on page 244](#)
- [DC Power Electrical Safety Guidelines for Switches on page 246](#)

Radiation and Laser Safety Guidelines and Warnings

- [Laser and LED Safety Guidelines and Warnings on page 231](#)
- [Radiation from Open Port Apertures Warning on page 233](#)

Laser and LED Safety Guidelines and Warnings

Juniper Networks devices are equipped with laser transmitters, which are considered a Class 1 Laser Product by the U.S. Food and Drug Administration and are evaluated as a Class 1 Laser Product per EN 60825-1 requirements.

Observe the following guidelines and warnings:

- [General Laser Safety Guidelines on page 231](#)
- [Class 1 Laser Product Warning on page 232](#)
- [Class 1 LED Product Warning on page 232](#)
- [Laser Beam Warning on page 232](#)

General Laser Safety Guidelines

When working around ports that support optical transceivers, observe the following safety guidelines to prevent eye injury:

- Do not look into unterminated ports or at fibers that connect to unknown sources.
- Do not examine unterminated optical ports with optical instruments.
- Avoid direct exposure to the beam.



WARNING: Unterminated optical connectors can emit invisible laser radiation. The lens in the human eye focuses all the laser power on the retina, so focusing the eye directly on a laser source—even a low-power laser—could permanently damage the eye.

Class 1 Laser Product Warning



WARNING: Class 1 laser product.

Waarschuwing Klasse-1 laser produkt.

Varoitus Luokan 1 lasertuote.

Attention Produit laser de classe I.

Warnung Laserprodukt der Klasse 1.

Avvertenza Prodotto laser di Classe 1.

Advarsel Laserprodukt av klasse 1.

Aviso Produto laser de classe 1.

¡Atención! Producto láser Clase I.

Varning! Laserprodukt av klass 1.

Class 1 LED Product Warning



WARNING: Class 1 LED product.

Waarschuwing Klasse 1 LED-product.

Varoitus Luokan 1 valodiodituote.

Attention Alarme de produit LED Class I.

Warnung Class 1 LED-Produktwarnung.

Avvertenza Avvertenza prodotto LED di Classe 1.

Advarsel LED-produkt i klasse 1.

Aviso Produto de classe 1 com LED.

¡Atención! Aviso sobre producto LED de Clase 1.

Varning! Lysdiodprodukt av klass 1.

Laser Beam Warning



WARNING: Do not stare into the laser beam or view it directly with optical instruments.

Waarschuwing Niet in de straal staren of hem rechtstreeks bekijken met optische instrumenten.

Varoitus Älä katso säteeseen äläkä tarkastele sitä suoraan optisen laitteen avulla.

Attention Ne pas fixer le faisceau des yeux, ni l'observer directement à l'aide d'instruments optiques.

Warnung Nicht direkt in den Strahl blicken und ihn nicht direkt mit optischen Geräten prüfen.

Avvertenza Non fissare il raggio con gli occhi né usare strumenti ottici per osservarlo direttamente.

Advarsel Stirr eller se ikke direkte p strlen med optiske instrumenter.

Aviso Não olhe fixamente para o raio, nem olhe para ele directamente com instrumentos ópticos.

¡Atención! No mirar fijamente el haz ni observarlo directamente con instrumentos ópticos.

Varning! Rikta inte blicken in mot strålen och titta inte direkt på den genom optiska instrument.

**Related
Documentation**

- [General Safety Guidelines and Warnings on page 213](#)
- [Radiation from Open Port Apertures Warning on page 233](#)
- [Installation Instructions Warning on page 221](#)
- [Grounded Equipment Warning on page 228](#)

Radiation from Open Port Apertures Warning



WARNING: Because invisible radiation might be emitted from the aperture of the port when no fiber cable is connected, avoid exposure to radiation and do not stare into open apertures.

Waarschuwing Aangezien onzichtbare straling vanuit de opening van de poort kan komen als er geen fiberkabel aangesloten is, dient blootstelling aan straling en het kijken in open openingen vermeden te worden.

Varoitus Koska portin aukosta voi emittoitua näkymätöntä säteilyä, kun kuitukaapelia ei ole kytkettynä, vältä säteilylle altistumisista äläkä katso avoimiin aukkoihin.

Attention Des radiations invisibles à l'il nu pouvant traverser l'ouverture du port lorsqu'aucun câble en fibre optique n'y est connecté, il est recommandé de ne pas regarder fixement l'intérieur de ces ouvertures.

Warnung Aus der Port-Öffnung können unsichtbare Strahlen emittieren, wenn kein Glasfaserkabel angeschlossen ist. Vermeiden Sie es, sich den Strahlungen auszusetzen, und starren Sie nicht in die Öffnungen!

Avvertenza Quando i cavi in fibra non sono inseriti, radiazioni invisibili possono essere emesse attraverso l'apertura della porta. Evitate di esporvi alle radiazioni e non guardate direttamente nelle aperture.

Advarsel Unngå utsettelse for stråling, og stirr ikke inn i åpninger som er åpne, fordi usynlig stråling kan emitteres fra portens åpning når det ikke er tilkoblet en fiberkabel.

Aviso Dada a possibilidade de emissão de radiação invisível através do orifício da via de acesso, quando esta não tiver nenhum cabo de fibra conectado, deverá evitar a exposição à radiação e não deverá olhar fixamente para orifícios que se encontrarem a descoberto.

¡Atención! Debido a que la apertura del puerto puede emitir radiación invisible cuando no existe un cable de fibra conectado, evite mirar directamente a las aperturas para no exponerse a la radiación.

Varning! Osynlig strålning kan avges från en portöppning utan ansluten fiberkabel och du bör därför undvika att bli utsatt för strålning genom att inte stirra in i oskyddade öppningar.

**Related
Documentation**

- [General Safety Guidelines and Warnings on page 213](#)
- [Laser and LED Safety Guidelines and Warnings on page 231](#)
- [Laser and LED Safety Guidelines and Warnings for the ACX5000 Router](#)
- [Installation Instructions Warning on page 221](#)
- [Grounded Equipment Warning on page 228](#)

Maintenance and Operational Safety Warnings

- [Maintenance and Operational Safety Guidelines and Warnings on page 235](#)

Maintenance and Operational Safety Guidelines and Warnings

While performing the maintenance activities for devices, observe the following guidelines and warnings:

- [Battery Handling Warning on page 235](#)
- [Jewelry Removal Warning on page 236](#)
- [Lightning Activity Warning on page 237](#)
- [Operating Temperature Warning on page 238](#)
- [Product Disposal Warning on page 239](#)

Battery Handling Warning



WARNING: Replacing a battery incorrectly might result in an explosion.

Replace a battery only with the same or equivalent type recommended by the manufacturer. Dispose of used batteries according to the manufacturer's instructions.

Waarschuwing Er is ontploffingsgevaar als de batterij verkeerd vervangen wordt. Vervang de batterij slechts met hetzelfde of een equivalent type dat door de fabrikant aanbevolen is. Gebruikte batterijen dienen overeenkomstig fabrieksvoorschriften weggeworpen te worden.

Varoitus Räjähdyksen vaara, jos akku on vaihdettu väärään akkuun. Käytä vaihtamiseen ainoastaan saman- tai vastaaventyyppistä akkua, joka on valmistajan suosittelema. Hävitä käytetyt akut valmistajan ohjeiden mukaan.

Attention Danger d'explosion si la pile n'est pas remplacée correctement. Ne la remplacer que par une pile de type semblable ou équivalent, recommandée par le fabricant. Jeter les piles usagées conformément aux instructions du fabricant.

Warnung Bei Einsetzen einer falschen Batterie besteht Explosionsgefahr. Ersetzen Sie die Batterie nur durch den gleichen oder vom Hersteller empfohlenen Batterietyp. Entsorgen Sie die benutzten Batterien nach den Anweisungen des Herstellers.

Advarsel Det kan være fare for eksplosjon hvis batteriet skiftes på feil måte. Skift kun med samme eller tilsvarende type som er anbefalt av produsenten. Kasser brukte batterier i henhold til produsentens instruksjoner.

Avvertenza Pericolo di esplosione se la batteria non è installata correttamente. Sostituire solo con una di tipo uguale o equivalente, consigliata dal produttore. Eliminare le batterie usate secondo le istruzioni del produttore.

Aviso Existe perigo de explosão se a bateria for substituída incorrectamente. Substitua a bateria por uma bateria igual ou de um tipo equivalente recomendado pelo fabricante. Destrua as baterias usadas conforme as instruções do fabricante.

¡Atención! Existe peligro de explosión si la batería se reemplaza de manera incorrecta. Reemplazar la batería exclusivamente con el mismo tipo o el equivalente recomendado por el fabricante. Desechar las baterías gastadas según las instrucciones del fabricante.

Varning! Explosionsfara vid felaktigt batteribyte. Ersätt endast batteriet med samma batterityp som rekommenderas av tillverkaren eller motsvarande. Följ tillverkarens anvisningar vid kassering av använda batterier.

Jewelry Removal Warning



WARNING: Before working on equipment that is connected to power lines, remove jewelry, including rings, necklaces, and watches. Metal objects heat up when connected to power and ground and can cause serious burns or can be welded to the terminals.

Waarschuwing Alvorens aan apparatuur te werken die met elektrische leidingen is verbonden, sieraden (inclusief ringen, kettingen en horloges) verwijderen. Metalen voorwerpen worden warm wanneer ze met stroom en aarde zijn verbonden, en kunnen ernstige brandwonden veroorzaken of het metalen voorwerp aan de aansluitklemmen lassen.

Varoitus Ennen kuin työskentelet voimavirtajohtoihin kytkettyjen laitteiden parissa, ota pois kaikki korut (sormukset, kaulakorut ja kellot mukaan lukien). Metalliesineet kuumentuvat, kun ne ovat yhteydessä sähkövirran ja maan kanssa, ja ne voivat aiheuttaa vakavia palovammoja tai hitsata metalliesineet kiinni liitäntänapoihin.

Attention Avant d'accéder à cet équipement connecté aux lignes électriques, ôter tout bijou (anneaux, colliers et montres compris). Lorsqu'ils sont branchés

à l'alimentation et reliés à la terre, les objets métalliques chauffent, ce qui peut provoquer des blessures graves ou souder l'objet métallique aux bornes.

Warnung Vor der Arbeit an Geräten, die an das Netz angeschlossen sind, jeglichen Schmuck (einschließlich Ringe, Ketten und Uhren) abnehmen. Metallgegenstände erhitzen sich, wenn sie an das Netz und die Erde angeschlossen werden, und können schwere Verbrennungen verursachen oder an die Anschlußklemmen angeschweißt werden.

Avvertenza Prima di intervenire su apparecchiature collegate alle linee di alimentazione, togliersi qualsiasi monile (inclusi anelli, collane, braccialetti ed orologi). Gli oggetti metallici si riscaldano quando sono collegati tra punti di alimentazione e massa: possono causare ustioni gravi oppure il metallo può saldarsi ai terminali.

Advarsel Fjern alle smykker (inkludert ringer, halskjeder og klokker) før du skal arbeide på utstyr som er koblet til kraftledninger. Metallgjenstander som er koblet til kraftledninger og jord blir svært varme og kan forårsake alvorlige brannskader eller smelte fast til polene.

Aviso Antes de trabalhar em equipamento que esteja ligado a linhas de corrente, retire todas as jóias que estiver a usar (incluindo anéis, fios e relógios). Os objectos metálicos aquecerão em contacto com a corrente e em contacto com a ligação à terra, podendo causar queimaduras graves ou ficarem soldados aos terminais.

¡Atención! Antes de operar sobre equipos conectados a líneas de alimentación, quitarse las joyas (incluidos anillos, collares y relojes). Los objetos de metal se calientan cuando se conectan a la alimentación y a tierra, lo que puede ocasionar quemaduras graves o que los objetos metálicos queden soldados a los bornes.

Varning! Tag av alla smycken (inklusive ringar, halsband och armbandsur) innan du arbetar på utrustning som är kopplad till kraftledningar. Metallobjekt hettas upp när de kopplas ihop med ström och jord och kan förorsaka allvarliga brännskador; metallobjekt kan också sammansvetsas med kontakterna.

Lightning Activity Warning



WARNING: Do not work on the system or connect or disconnect cables during periods of lightning activity.

Waarschuwing Tijdens onweer dat gepaard gaat met bliksem, dient u niet aan het systeem te werken of kabels aan te sluiten of te ontkoppelen.

Varoitus Älä työskentele järjestelmän parissa äläkä yhdistä tai irrota kaapeleita ukkosilmalla.

Attention Ne pas travailler sur le système ni brancher ou débrancher les câbles pendant un orage.

Warnung Arbeiten Sie nicht am System und schließen Sie keine Kabel an bzw. trennen Sie keine ab, wenn es gewittert.

Avvertenza Non lavorare sul sistema o collegare oppure scollegare i cavi durante un temporale con fulmini.

Advarsel Utfør aldri arbeid på systemet, eller koble kabler til eller fra systemet når det tordner eller lyner.

Aviso Não trabalhe no sistema ou ligue e desligue cabos durante períodos de mau tempo (trovoada).

¡Atención! No operar el sistema ni conectar o desconectar cables durante el transcurso de descargas eléctricas en la atmósfera.

Varning! Vid åska skall du aldrig utföra arbete på systemet eller ansluta eller koppla loss kablar.

Operating Temperature Warning



WARNING: To prevent the device from overheating, do not operate it in an area that exceeds the maximum recommended ambient temperature. To prevent airflow restriction, allow at least 6 in. (15.2 cm) of clearance around the ventilation openings.

Waarschuwing Om te voorkomen dat welke switch van de Juniper Networks router dan ook oververhit raakt, dient u deze niet te bedienen op een plaats waar de maximale aanbevolen omgevingstemperatuur van 40° C wordt overschreden. Om te voorkomen dat de luchtstroom wordt beperkt, dient er minstens 15,2 cm speling rond de ventilatie-openingen te zijn.

Varoitus Ettei Juniper Networks switch-sarjan reititin ylikuumentuusi, sitä ei saa käyttää tilassa, jonka lämpötila ylittää korkeimman suositellun ympäristölämpötilan 40° C. Ettei ilmanvaihto estyisi, tuuletusaukkojen ympärille on jätettävä ainakin 15,2 cm tilaa.

Attention Pour éviter toute surchauffe des routeurs de la gamme Juniper Networks switch, ne l'utilisez pas dans une zone où la température ambiante est supérieure à 40° C. Pour permettre un flot d'air constant, dégagez un espace d'au moins 15,2 cm autour des ouvertures de ventilations.

Warnung Um einen Router der switch vor Überhitzung zu schützen, darf dieser nicht in einer Gegend betrieben werden, in der die Umgebungstemperatur das empfohlene Maximum von 40° C überschreitet. Um Lüftungsverschluß zu verhindern, achten Sie darauf, daß mindestens 15,2 cm lichter Raum um die Lüftungsöffnungen herum frei bleibt.

Avvertenza Per evitare il surriscaldamento dei switch, non adoperateli in un locale che ecceda la temperatura ambientale massima di 40° C. Per evitare che la circolazione dell'aria sia impedita, lasciate uno spazio di almeno 15.2 cm di fronte alle aperture delle ventole.

Advarsel Unngå overoppheting av eventuelle rutere i Juniper Networks switch Disse skal ikke brukes på steder der den anbefalte maksimale omgivelsestemperaturen overstiger 40° C (104° F). Sørg for at klaringen rundt lufteåpningene er minst 15,2 cm (6 tommer) for å forhindre nedsatt luftsirkulasjon.

Aviso Para evitar o sobreaquecimento do encaminhador Juniper Networks switch, não utilize este equipamento numa área que exceda a temperatura máxima recomendada de 40° C. Para evitar a restrição à circulação de ar, deixe pelo menos um espaço de 15,2 cm à volta das aberturas de ventilação.

¡Atención! Para impedir que un encaminador de la serie Juniper Networks switch se recaliente, no lo haga funcionar en un área en la que se supere la temperatura ambiente máxima recomendada de 40° C. Para impedir la restricción de la entrada de aire, deje un espacio mínimo de 15,2 cm alrededor de las aberturas para ventilación.

Varning! Förhindra att en Juniper Networks switch överhettas genom att inte använda den i ett område där den maximalt rekommenderade omgivningstemperaturen på 40° C överskrids. Förhindra att luftcirkulationen inskränks genom att se till att det finns fritt utrymme på minst 15,2 cm omkring ventilationsöppningarna.

Product Disposal Warning



WARNING: Disposal of this device must be handled according to all national laws and regulations.

Waarschuwing Dit produkt dient volgens alle landelijke wetten en voorschriften te worden afgedankt.

Varoitus Tämän tuotteen lopullisesta hävittämisestä tulee huolehtia kaikkia valtakunnallisia lakeja ja säännöksiä noudattaen.

Attention La mise au rebut définitive de ce produit doit être effectuée conformément à toutes les lois et réglementations en vigueur.

Warnung Dieses Produkt muß den geltenden Gesetzen und Vorschriften entsprechend entsorgt werden.

Avvertenza L'eliminazione finale di questo prodotto deve essere eseguita osservando le normative italiane vigenti in materia

Advarsel Endelig disponering av dette produktet må skje i henhold til nasjonale lover og forskrifter.

Aviso A descartagem final deste produto deverá ser efectuada de acordo com os regulamentos e a legislação nacional.

¡Atención! El desecho final de este producto debe realizarse según todas las leyes y regulaciones nacionales

Varning! Slutlig kassering av denna produkt bör skötas i enlighet med landets alla lagar och föreskrifter.

**Related
Documentation**

- [General Safety Guidelines and Warnings on page 213](#)
- [General Electrical Safety Guidelines and Warnings on page 241](#)
- [AC Power Electrical Safety Guidelines on page 244](#)
- [DC Power Electrical Safety Guidelines for Switches on page 246](#)
- [Laser and LED Safety Guidelines and Warnings on page 231](#)
- [Laser and LED Safety Guidelines and Warnings for the ACX5000 Router](#)
- [Installation Instructions Warning on page 221](#)
- [Grounded Equipment Warning on page 228](#)

Electrical Safety Guidelines and Warnings

- General Electrical Safety Guidelines and Warnings on page 241
- Action to Take After an Electrical Accident on page 242
- Prevention of Electrostatic Discharge Damage on page 243
- AC Power Electrical Safety Guidelines on page 244
- AC Power Disconnection Warning on page 245
- DC Power Electrical Safety Guidelines for Switches on page 246
- DC Power Disconnection Warning on page 249
- DC Power Grounding Requirements and Warning on page 250
- DC Power Wiring Sequence Warning on page 251
- DC Power Wiring Terminations Warning on page 253
- Multiple Power Supplies Disconnection Warning on page 254
- TN Power Warning on page 254

General Electrical Safety Guidelines and Warnings



WARNING: Certain ports on the device are designed for use as intrabuilding (within-the-building) interfaces only (Type 2 or Type 4 ports as described in *GR-1089-CORE*) and require isolation from the exposed outside plant (OSP) cabling. To comply with NEBS requirements and protect against lightning surges and commercial power disturbances, the intrabuilding ports *must not* be metallically connected to interfaces that connect to the OSP or its wiring. The intrabuilding ports on the device are suitable for connection to intrabuilding or unexposed wiring or cabling only. The addition of primary protectors is not sufficient protection for connecting these interfaces metallically to OSP wiring.



CAUTION: Before removing or installing components of a device, attach an electrostatic discharge (ESD) grounding strap to an ESD point and place the other end of the strap around your bare wrist. Failure to use an ESD grounding strap could result in damage to the device.

- Install the device in compliance with the following local, national, and international electrical codes:
 - United States—National Fire Protection Association (NFPA 70), United States National Electrical Code.
 - Other countries—International Electromechanical Commission (IEC) 60364, Part 1 through Part 7.
 - Evaluated to the TN power system.
 - Canada—Canadian Electrical Code, Part 1, CSA C22.1.
- Locate the emergency power-off switch for the room in which you are working so that if an electrical accident occurs, you can quickly turn off the power.
- Make sure that grounding surfaces are cleaned and brought to a bright finish before grounding connections are made.
- Do not work alone if potentially hazardous conditions exist anywhere in your workspace.
- Never assume that power is disconnected from a circuit. Always check the circuit before starting to work.
- Carefully look for possible hazards in your work area, such as moist floors, ungrounded power extension cords, and missing safety grounds.
- Operate the device within marked electrical ratings and product usage instructions.
- To ensure that the device and peripheral equipment function safely and correctly, use the cables and connectors specified for the attached peripheral equipment, and make certain they are in good condition.

You can remove and replace many device components without powering off or disconnecting power to the device, as detailed elsewhere in the hardware documentation for this device. Never install equipment that appears to be damaged.

Related Documentation

- [General Safety Guidelines and Warnings on page 213](#)
- [AC Power Electrical Safety Guidelines on page 244](#)
- [DC Power Electrical Safety Guidelines for Switches on page 246](#)

Action to Take After an Electrical Accident

If an electrical accident results in an injury, take the following actions in this order:

1. Use caution. Be aware of potentially hazardous conditions that could cause further injury.
2. Disconnect power from the device.
3. If possible, send another person to get medical aid. Otherwise, assess the condition of the victim, then call for help.

- Related Documentation**
- [General Safety Guidelines and Warnings on page 213](#)
 - [General Electrical Safety Guidelines and Warnings on page 241](#)
 - [AC Power Electrical Safety Guidelines on page 244](#)
 - [DC Power Electrical Safety Guidelines for Switches on page 246](#)

Prevention of Electrostatic Discharge Damage

Device components that are shipped in antistatic bags are sensitive to damage from static electricity. Some components can be impaired by voltages as low as 30 V. You can easily generate potentially damaging static voltages whenever you handle plastic or foam packing material or if you move components across plastic or carpets. Observe the following guidelines to minimize the potential for electrostatic discharge (ESD) damage, which can cause intermittent or complete component failures:

- Always use an ESD grounding strap when you are handling components that are subject to ESD damage, and make sure that it is in direct contact with your skin.

If a grounding strap is not available, hold the component in its antistatic bag (see [Figure 76 on page 244](#)) in one hand and touch the exposed, bare metal of the device with the other hand immediately before inserting the component into the device.



WARNING: For safety, periodically check the resistance value of the ESD grounding strap. The measurement must be in the range 1 through 10 Mohms.

- When handling any component that is subject to ESD damage and that is removed from the device, make sure the equipment end of your ESD grounding strap is attached to the ESD point on the chassis.

If no grounding strap is available, touch the exposed, bare metal of the device to ground yourself before handling the component.

- Avoid contact between the component that is subject to ESD damage and your clothing. ESD voltages emitted from clothing can damage components.
- When removing or installing a component that is subject to ESD damage, always place it component-side up on an antistatic surface, in an antistatic card rack, or in an antistatic bag (see [Figure 76 on page 244](#)). If you are returning a component, place it in an antistatic bag before packing it.

Figure 76: Placing a Component into an Antistatic Bag

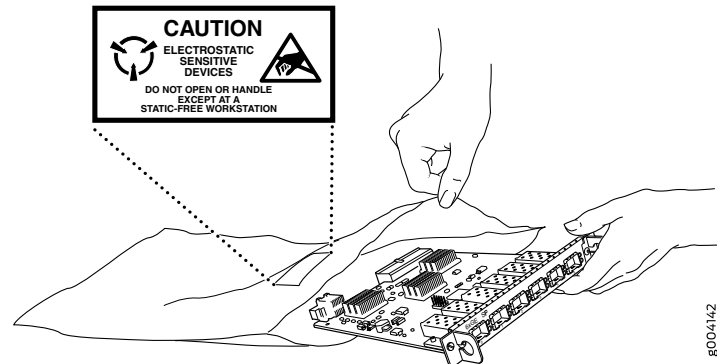

CAUTION: ANSI/TIA/EIA-568 cables such as Category 5e and Category 6 can get electrostatically charged. To dissipate this charge, always ground the cables to a suitable and safe earth ground before connecting them to the system.

Related Documentation

- [General Safety Guidelines and Warnings on page 213](#)

AC Power Electrical Safety Guidelines



CAUTION: For devices with AC power supplies, an external surge protective device (SPD) must be used at the AC power source.

The following electrical safety guidelines apply to AC-powered devices:

- Note the following warnings printed on the device:
 - “**CAUTION:** THIS UNIT HAS MORE THAN ONE POWER SUPPLY CORD. DISCONNECT ALL POWER SUPPLY CORDS BEFORE SERVICING TO AVOID ELECTRIC SHOCK.”
 - “**ATTENTION:** CET APPAREIL COMPORTE PLUS D'UN CORDON D'ALIMENTATION. AFIN DE PRÉVENIR LES CHOCS ÉLECTRIQUES, DÉBRANCHER TOUT CORDON D'ALIMENTATION AVANT DE FAIRE LE DÉPANNAGE.”
- AC-powered devices are shipped with a three-wire electrical cord with a grounding-type plug that fits only a grounding-type power outlet. Do not circumvent this safety feature. Equipment grounding must comply with local and national electrical codes.
- You must provide an external certified circuit breaker rated minimum 20 A in the building installation.

- The power cord serves as the main disconnecting device for the AC-powered device. The socket outlet must be near the AC-powered device and be easily accessible.
- For devices that have more than one power supply connection, you must ensure that all power connections are fully disconnected so that power to the device is completely removed to prevent electric shock. To disconnect power, unplug all power cords (one for each power supply).

Power Cable Warning (Japanese)

WARNING: The attached power cable is only for this product. Do not use the cable for another product.

注意

附属の電源コードセットはこの製品専用です。
他の電気機器には使用しないでください。

g017253

- Related Documentation**
- [General Safety Guidelines and Warnings on page 213](#)
 - [General Electrical Safety Guidelines and Warnings on page 241](#)
 - [Multiple Power Supplies Disconnection Warning on page 254](#)

AC Power Disconnection Warning



WARNING: Before working on the device or near power supplies, unplug all the power cords from an AC-powered device.

Waarschuwing Voordat u aan een frame of in de nabijheid van voedingen werkt, dient u bij wisselstroom toestellen de stekker van het netsnoer uit het stopcontact te halen.

Varoitus Kytke irti vaihtovirtalaitteiden virtajohto, ennen kuin teet mitään asennuspohjalle tai työskentelet virtalähteiden läheisyydessä.

Attention Avant de travailler sur un châssis ou à proximité d'une alimentation électrique, débrancher le cordon d'alimentation des unités en courant alternatif.

Warnung Bevor Sie an einem Chassis oder in der Nähe von Netzgeräten arbeiten, ziehen Sie bei Wechselstromeinheiten das Netzkabel ab bzw.

Avvertenza Prima di lavorare su un telaio o intorno ad alimentatori, scollegare il cavo di alimentazione sulle unità CA.

Advarsel Før det utføres arbeid på kabinettet eller det arbeides i nærheten av strømforsyningsenheter, skal strømledningen trekkes ut på vekselstrømsenheter.

Aviso Antes de trabalhar num chassis, ou antes de trabalhar perto de unidades de fornecimento de energia, desligue o cabo de alimentação nas unidades de corrente alternada.

¡Atención! Antes de manipular el chasis de un equipo o trabajar cerca de una fuente de alimentación, desenchufar el cable de alimentación en los equipos de corriente alterna (CA).

Varning! Innan du arbetar med ett chassi eller nära strömförsörjningsenheter skall du för växelströmsenheter dra ur nätsladden.

- Related Documentation**
- [General Safety Guidelines and Warnings on page 213](#)
 - [General Electrical Safety Guidelines and Warnings on page 241](#)
 - [AC Power Electrical Safety Guidelines on page 244](#)

DC Power Electrical Safety Guidelines for Switches

This topic applies to hardware devices in the EX Series product family, which includes EX Series switches and the XRE200 External Routing Engine.

This topic also applies to hardware devices in the QFX Series and to OCX1100 switches.

- A DC-powered device is equipped with a DC terminal block that is rated for the power requirements of a maximally configured device.



NOTE: To supply sufficient power, terminate the DC input wiring on a facility DC source that is capable of supplying:

- Minimum of 7.5 A at –48 VDC for EX2200, EX2300, EX3300, and EX3400 switches
- Minimum of 8 A at –48 VDC for EX3200 and EX4200 switches
- Minimum of 20 A at –48 VDC for EX4300, EX4500, EX4550, and QFX10002 switches
- Minimum of 50 A at –48 VDC for EX6210 switches
- Minimum of 60 A at –48 VDC for EX8208, QFX10008 and QFX10016 switches
- Minimum of 100 A at –48 VDC for EX8216 switches
- Minimum of 7 A at –48 VDC for QFX3500, EX4600, QFX5100, QFX5110, and QFX5200 devices
- Minimum of 8 A at –48 VDC for QFX3600 devices
- Minimum of 7 A at –48 VDC for OCX1100 switches

Incorporate an easily accessible disconnect device into the facility wiring. Be sure to connect the ground wire or conduit to a solid office earth ground. A closed loop ring is recommended for terminating the ground conductor at the ground stud.

- Run two wires from the circuit breaker box to a source of 48 VDC.
- A DC-powered device that is equipped with a DC terminal block is intended only for installation in a restricted-access location. In the United States, a restricted-access area is one in accordance with Articles 110-16, 110-17, and 110-18 of the National Electrical Code ANSI/NFPA 70.



NOTE: Primary overcurrent protection is provided by the building circuit breaker. This breaker must protect against excess currents, short circuits, and earth grounding faults in accordance with NEC ANSI/NFPA 70.

- Ensure that the polarity of the DC input wiring is correct. Under certain conditions, connections with reversed polarity might trip the primary circuit breaker or damage the equipment.
- For personal safety, connect the green and yellow wire to safety (earth) ground at both the device and the supply side of the DC wiring.

- The marked input voltage of –48 VDC for a DC-powered device is the nominal voltage associated with the battery circuit, and any higher voltages are only to be associated with float voltages for the charging function.
- Because the device is a positive ground system, you must connect the positive lead to the terminal labeled **RTN**, the negative lead to the terminal labeled –48 VDC, and the earth ground to the device grounding points.

Related Documentation

- [General Safety Guidelines and Warnings on page 213](#)
- [General Electrical Safety Guidelines and Warnings on page 241](#)
- [DC Power Disconnection Warning on page 249](#)
- [DC Power Grounding Requirements and Warning on page 250](#)
- [DC Power Wiring Sequence Warning on page 251](#)
- [DC Power Wiring Terminations Warning on page 253](#)
- *Connecting DC Power to an EX2200 Switch*
- [Connecting DC Power to an EX2300 Switch on page 143](#)
- *Connecting DC Power to an EX3200 Switch*
- *Connecting DC Power to an EX3400 Switch*
- *Connecting DC Power to an EX4200 Switch*
- *Connecting DC Power to an EX4300 Switch*
- *Connecting DC Power to an EX4500 Switch*
- *Connecting DC Power to an EX4550 Switch*
- *Connecting DC Power to an EX4600 Switch*
- *Connecting DC Power to an EX6200 Switch*
- *Connecting DC Power to an EX8200 Switch*
- *Connecting DC Power to an EX9204 Switch*
- *Connecting DC Power to an EX9208 Switch*
- *Connecting DC Power to an EX9214 Switch*
- *Connecting DC Power to an OCX1100 Switch*
- *Connecting DC Power to an XRE200 External Routing Engine*
- *Connecting DC Power to a QFX3500, QFX3600, or QFX3600-I Device*
- *Connecting DC Power to a QFX5100 Device*
- *Connecting DC Power to a QFX5200*
- *Connecting DC Power to a QFX10002*
- *Connecting DC Power to a QFX10000*

DC Power Disconnection Warning



WARNING: Before performing any of the DC power procedures, ensure that power is removed from the DC circuit. To ensure that all power is off, locate the circuit breaker on the panel board that services the DC circuit, switch the circuit breaker to the OFF position, and tape the device handle of the circuit breaker in the OFF position.

Waarschuwing Voordat u een van de onderstaande procedures uitvoert, dient u te controleren of de stroom naar het gelijkstroom circuit uitgeschakeld is. Om u ervan te verzekeren dat alle stroom UIT is geschakeld, kiest u op het schakelbord de stroomverbreker die het gelijkstroom circuit bedient, draait de stroomverbreker naar de UIT positie en plakt de schakelaarhendel van de stroomverbreker met plakband in de UIT positie vast.

Varoitus Varmista, että tasavirtapiirissä ei ole virtaa ennen seuraavien toimenpiteiden suorittamista. Varmistaaksesi, että virta on KATKAISTU täysin, paikanna tasavirrasta huolehtivassa kojetaulussa sijaitseva suojakytkin, käännä suojakytkin KATKAISTU-asentoon ja teippaa suojakytkimen varsi niin, että se pysyy KATKAISTU-asennossa.

Attention Avant de pratiquer l'une quelconque des procédures ci-dessous, vérifiez que le circuit en courant continu n'est plus sous tension. Pour en être sûr, localiser le disjoncteur situé sur le panneau de service du circuit en courant continu, placer le disjoncteur en position fermée (OFF) et, à l'aide d'un ruban adhésif, bloquer la poignée du disjoncteur en position OFF.

Warnung Vor Ausführung der folgenden Vorgänge ist sicherzustellen, daß die Gleichstromschaltung keinen Strom erhält. Um sicherzustellen, daß sämtlicher Strom abgestellt ist, machen Sie auf der Schalttafel den Unterbrecher für die Gleichstromschaltung ausfindig, stellen Sie den Unterbrecher auf AUS, und kleben Sie den Schaltergriff des Unterbrechers mit Klebeband in der AUS-Stellung fest.

Avvertenza Prima di svolgere una qualsiasi delle procedure seguenti, verificare che il circuito CC non sia alimentato. Per verificare che tutta l'alimentazione sia scollegata (OFF), individuare l'interruttore automatico sul quadro strumenti che alimenta il circuito CC, mettere l'interruttore in posizione OFF e fissarlo con nastro adesivo in tale posizione.

Advarsel Før noen av disse prosedyrene utføres, kontroller at strømmen er frakoblet likestrømkretsen. Sørg for at all strøm er slått AV. Dette gjøres ved å lokalisere strømbryteren på brytertavlen som betjener likestrømkretsen, slå strømbryteren AV og teipe bryterhåndtaket på strømbryteren i AV-stilling.

Aviso Antes de executar um dos seguintes procedimentos, certifique-se que desligou a fonte de alimentação de energia do circuito de corrente contínua. Para se assegurar que toda a corrente foi DESLIGADA, localize o disjuntor no

painel que serve o circuito de corrente contínua e coloque-o na posição OFF (Desligado), segurando nessa posição a manivela do interruptor do disjuntor com fita isoladora.

¡Atención! Antes de proceder con los siguientes pasos, comprobar que la alimentación del circuito de corriente continua (CC) esté cortada (OFF). Para asegurarse de que toda la alimentación esté cortada (OFF), localizar el interruptor automático en el panel que alimenta al circuito de corriente continua, cambiar el interruptor automático a la posición de Apagado (OFF), y sujetar con cinta la palanca del interruptor automático en posición de Apagado (OFF).

Warning! Innan du utför någon av följande procedurer måste du kontrollera att strömförsörjningen till likströmskretsen är bruten. Kontrollera att all strömförsörjning är BRUTEN genom att slå AV det överspänningsskydd som skyddar likströmskretsen och tejpa fast överspänningsskyddets omkopplare i FRÅN-läget.

Related Documentation

- [General Safety Guidelines and Warnings on page 213](#)
- [General Electrical Safety Guidelines and Warnings on page 241](#)
- [DC Power Electrical Safety Guidelines for Switches on page 246](#)
- [DC Power Grounding Requirements and Warning on page 250](#)
- [DC Power Wiring Sequence Warning on page 251](#)
- [DC Power Wiring Terminations Warning on page 253](#)

DC Power Grounding Requirements and Warning

An insulated grounding conductor that is identical in size to the grounded and ungrounded branch circuit supply conductors but is identifiable by green and yellow stripes is installed as part of the branch circuit that supplies the device. The grounding conductor is a separately derived system at the supply transformer or motor generator set.



WARNING: When you install the device, the ground connection must always be made first and disconnected last.

Waarschuwing Bij de installatie van het toestel moet de aardverbinding altijd het eerste worden gemaakt en het laatste worden losgemaakt.

Varoitus Laitetta asennettaessa on maahan yhdistäminen aina tehtävä ensiksi ja maadoituksen irti kytkeminen viimeiseksi.

Attention Lors de l'installation de l'appareil, la mise à la terre doit toujours être connectée en premier et déconnectée en dernier.

Warnung Der Erdanschluß muß bei der Installation der Einheit immer zuerst hergestellt und zuletzt abgetrennt werden.

Avvertenza In fase di installazione dell'unità, eseguire sempre per primo il collegamento a massa e disconnetterlo per ultimo.

Advarsel Når enheten installeres, må jordledningen alltid tilkobles først og frakobles sist.

Aviso Ao instalar a unidade, a ligação à terra deverá ser sempre a primeira a ser ligada, e a última a ser desligada.

¡Atención! Al instalar el equipo, conectar la tierra la primera y desconectarla la última.

Varning! Vid installation av enheten måste jordledningen alltid anslutas först och kopplas bort sist.

Related Documentation

- [General Safety Guidelines and Warnings on page 213](#)
- [General Electrical Safety Guidelines and Warnings on page 241](#)
- [DC Power Electrical Safety Guidelines for Switches on page 246](#)
- [DC Power Copper Conductors Warning](#)
- [DC Power Disconnection Warning on page 249](#)
- [DC Power Wiring Sequence Warning on page 251](#)
- [DC Power Wiring Terminations Warning on page 253](#)

DC Power Wiring Sequence Warning



WARNING: Wire the DC power supply using the appropriate lugs. When connecting power, the proper wiring sequence is ground to ground, +RTN to +RTN, then –48 V to –48 V. When disconnecting power, the proper wiring sequence is –48 V to –48 V, +RTN to +RTN, then ground to ground. Note that the ground wire must always be connected first and disconnected last.

Waarschuwing De juiste bedradingsvolgorde verbonden is aarde naar aarde, +RTN naar +RTN, en –48 V naar –48 V. De juiste bedradingsvolgorde losgemaakt is en –48 naar –48 V, +RTN naar +RTN, aarde naar aarde.

Varoitus Oikea yhdistettävä kytkentäjärytitys on maajohto maajohtoon, +RTN varten +RTN, –48 V varten –48 V. Oikea irrotettava kytkentäjärytitys on –48 V varten –48 V, +RTN varten +RTN, maajohto maajohtoon.

Attention Câblez l'alimentation CC En utilisant les crochets appropriés à l'extrémité de câblage. En reliant la puissance, l'ordre

approprié de câblage est rectifié pour rectifier, +RTN à +RTN, puis -48 V à -48 V. En débranchant la puissance, l'ordre approprié de câblage est -48 V à -48 V, +RTN à +RTN, a alors rectifié pour rectifier. Notez que le fil de masse devrait toujours être relié d'abord et débranché pour la dernière fois. Notez que le fil de masse devrait toujours être relié d'abord et débranché pour la dernière fois.

Warnung Die Stromzufuhr ist nur mit geeigneten Ringösen an das DC Netzteil anzuschliessen. Die richtige Anschlusssequenz ist: Erdanschluss zu Erdanschluss, +RTN zu +RTN und dann -48V zu -48V. Die richtige Sequenz zum Abtrennen der Stromversorgung ist -48V zu -48V, +RTN zu +RTN und dann Erdanschluss zu Erdanschluss. Es ist zu beachten dass der Erdanschluss immer zuerst angeschlossen und als letztes abgetrennt wird.

Avvertenza Mostra la morsettiera dell'alimentatore CC. Cablare l'alimentatore CC usando i connettori adatti all'estremità del cablaggio, come illustrato. La corretta sequenza di cablaggio è da massa a massa, da positivo a positivo (da linea ad L) e da negativo a negativo (da neutro a N). Tenere presente che il filo di massa deve sempre venire collegato per primo e scollegato per ultimo.

Advarsel Riktig tilkoples tilkoplingssekvens er jord til jord, +RTN til +RTN, -48 V til -48 V. Riktig frakoples tilkoplingssekvens er -48 V til -48 V, +RTN til +RTN, jord til jord.

Aviso Ate con alambre la fuente de potencia cc Usando los terminales apropiados en el extremo del cableado. Al conectar potencia, la secuencia apropiada del cableado se muele para moler, +RTN a +RTN, entonces -48 V a -48 V. Al desconectar potencia, la secuencia apropiada del cableado es -48 V a -48 V, +RTN a +RTN, entonces molió para moler. Observe que el alambre de tierra se debe conectar siempre primero y desconectar por último. Observe que el alambre de tierra se debe conectar siempre primero y desconectar por último.

¡Atención! Wire a fonte de alimentação de DC Usando os talões apropriados na extremidade da fiação. Ao conectar a potência, a seqüência apropriada da fiação é moída para moer, +RTN a +RTN, então -48 V a -48 V. Ao desconectar a potência, a seqüência apropriada da fiação é -48 V a -48 V, +RTN a +RTN, moeu então para moer. Anote que o fio à terra deve sempre ser conectado primeiramente e desconectado por último. Anote que o fio à terra deve sempre ser conectado primeiramente e desconectado por último.

Varning! Korrekt kopplingssekvens ar jord till jord, +RTN till +RTN, -48 V till -48 V. Korrekt kopplas kopplingssekvens ar -48 V till -48 V, +RTN till +RTN, jord till jord.

- Related Documentation**
- [General Safety Guidelines and Warnings on page 213](#)
 - [General Electrical Safety Guidelines and Warnings on page 241](#)

- [DC Power Electrical Safety Guidelines for Switches on page 246](#)
- [DC Power Disconnection Warning on page 249](#)
- [DC Power Grounding Requirements and Warning on page 250](#)
- [DC Power Wiring Terminations Warning on page 253](#)

DC Power Wiring Terminations Warning



WARNING: When stranded wiring is required, use approved wiring terminations, such as closed-loop or spade-type with upturned lugs. These terminations must be the appropriate size for the wires and must clamp both the insulation and conductor.

Waarschuwing Wanneer geslagen bedrading vereist is, dient u bedrading te gebruiken die voorzien is van goedgekeurde aansluitingspunten, zoals het gesloten-lus type of het grijperschop type waarbij de aansluitpunten omhoog wijzen. Deze aansluitpunten dienen de juiste maat voor de draden te hebben en dienen zowel de isolatie als de geleider vast te klemmen.

Varoitus Jos säikeellinen johdin on tarpeen, käytä hyväksyttyä johdinliitäntää, esimerkiksi suljettua silmukkaa tai kourumaista liitäntää, jossa on ylöspäin käännetyt kiinnityskorvat. Tällaisten liitäntöjen tulee olla kooltaan johtimiin sopivia ja niiden tulee puristaa yhteen sekä eristeen että johdinosan.

Attention Quand des fils torsadés sont nécessaires, utiliser des douilles terminales homologuées telles que celles à circuit fermé ou du type à plage ouverte avec cosses rebroussées. Ces douilles terminales doivent être de la taille qui convient aux fils et doivent être refermées sur la gaine isolante et sur le conducteur.

Warnung Wenn Litzenverdrahtung erforderlich ist, sind zugelassene Verdrahtungsabschlüsse, z.B. für einen geschlossenen Regelkreis oder gabelförmig, mit nach oben gerichteten Kabelschuhen zu verwenden. Diese Abschlüsse sollten die angemessene Größe für die Drähte haben und sowohl die Isolierung als auch den Leiter festklemmen.

Avvertenza Quando occorre usare trecce, usare connettori omologati, come quelli a occhio o a forcilla con linguette rivolte verso l'alto. I connettori devono avere la misura adatta per il cablaggio e devono serrare sia l'isolante che il conduttore.

Advarsel Hvis det er nødvendig med flertrådede ledninger, brukes godkjente ledningsavslutninger, som for eksempel lukket sløyfe eller spadetype med oppoverbøyde kabelsko. Disse avslutningene skal ha riktig størrelse i forhold til ledningene, og skal klemme sammen både isolasjonen og lederen.

Aviso Quando forem requeridas montagens de instalação eléctrica de cabo torcido, use terminações de cabo aprovadas, tais como, terminações de cabo

em circuito fechado e planas com terminais de orelha voltados para cima. Estas terminações de cabo deverão ser do tamanho apropriado para os respectivos cabos, e deverão prender simultaneamente o isolamento e o fio condutor.

¡Atención! Cuando se necesite hilo trenzado, utilizar terminales para cables homologados, tales como las de tipo "bucle cerrado" o "espada", con las lengüetas de conexión vueltas hacia arriba. Estos terminales deberán ser del tamaño apropiado para los cables que se utilicen, y tendrán que sujetar tanto el aislante como el conductor.

Warning! När flertrådiga ledningar krävs måste godkända ledningskontakter användas, t.ex. kabelsko av sluten eller öppen typ med uppåtvänd tapp. Storleken på dessa kontakter måste vara avpassad till ledningarna och måste kunna hålla både isoleringen och ledaren fastklämda.

Related Documentation

- [General Safety Guidelines and Warnings on page 213](#)
- [General Electrical Safety Guidelines and Warnings on page 241](#)
- [DC Power Electrical Safety Guidelines for Switches on page 246](#)
- [DC Power Disconnection Warning on page 249](#)
- [DC Power Grounding Requirements and Warning on page 250](#)
- [DC Power Wiring Sequence Warning on page 251](#)

Multiple Power Supplies Disconnection Warning



WARNING: For a device that has more than one power supply connection, you must ensure that all power connections are fully disconnected so that power to the device is completely removed.

Related Documentation

- [General Safety Guidelines and Warnings on page 213](#)
- [General Electrical Safety Guidelines and Warnings on page 241](#)
- [AC Power Electrical Safety Guidelines on page 244](#)
- [DC Power Electrical Safety Guidelines for Switches on page 246](#)

TN Power Warning



WARNING: The device is designed to work with a TN power system.

Waarschuwing Het apparaat is ontworpen om te functioneren met TN energiesystemen.

Varoitus Koje on suunniteltu toimimaan TN-sähkövoimajärjestelmien yhteydessä.

Attention Ce dispositif a été conçu pour fonctionner avec des systèmes d'alimentation TN.

Warnung Das Gerät ist für die Verwendung mit TN-Stromsystemen ausgelegt.

Avvertenza Il dispositivo è stato progettato per l'uso con sistemi di alimentazione TN.

Advarsel Utstyret er utfomet til bruk med TN-strømsystemer.

Aviso O dispositivo foi criado para operar com sistemas de corrente TN.

¡Atención! El equipo está diseñado para trabajar con sistemas de alimentación tipo TN.

Varning! Enheten är konstruerad för användning tillsammans med elkraftssystem av TN-typ.

**Related
Documentation**

- [General Safety Guidelines and Warnings on page 213](#)
- [General Electrical Safety Guidelines and Warnings on page 241](#)
- [Grounded Equipment Warning on page 228](#)
- [Multiple Power Supplies Disconnection Warning on page 254](#)

Agency Approvals and Compliance Statements

- [Agency Approvals for EX Series Switches on page 257](#)
- [Compliance Statements for EMC Requirements for EX Series Switches on page 258](#)
- [Compliance Statements for Acoustic Noise for EX Series Switches on page 262](#)

Agency Approvals for EX Series Switches

This topic applies to hardware devices in the EX Series product family, which includes EX Series switches, the EX Series Redundant Power System (RPS), and the XRE200 External Routing Engine.

These hardware devices comply with the following standards:

- Safety
 - CAN/CSA-C22.2 No. 60950-1 Information Technology Equipment
 - UL 60950-1 Information Technology Equipment
 - EN 60950-1 Information Technology Equipment
 - IEC 60950-1 Information Technology Equipment
 - EN 60825-1 Safety of Laser Products - Part 1: Equipment classification and requirements
- EMC
 - FCC 47CFR Part 15 Class A (USA)
 - EN 55022 Class A Emissions (Europe)
 - ICES-003 Class A
 - VCCI Class A (Japan)
 - AS/NZS CISPR 22 Class A (Australia/New Zealand)
 - CISPR 22 Class A
 - EN 55024
 - EN 300386

- EN 61000-3-2 Power Line Harmonics
- EN 61000-3-3 Voltage Fluctuations and Flicker
- EN 61000-4-2 ESD
- EN 61000-4-3 Radiated Immunity
- EN 61000-4-4 EFT
- EN 61000-4-5 Surge
- EN 61000-4-6 Low Frequency Common Immunity
- EN 61000-4-11 Voltage Dips and Sags

**Related
Documentation**

- [Compliance Statements for EMC Requirements for EX Series Switches on page 258](#)
- [Compliance Statements for Acoustic Noise for EX Series Switches on page 262](#)

Compliance Statements for EMC Requirements for EX Series Switches

This topic applies to hardware devices in the EX Series product family, which includes EX Series switches, the EX Series Redundant Power System (RPS), and the XRE200 External Routing Engine.

This topic describes the EMC requirements for these hardware devices for:

- [Canada on page 258](#)
- [European Community on page 259](#)
- [Israel on page 259](#)
- [Japan on page 259](#)
- [Korea on page 260](#)
- [United States on page 260](#)
- [FCC Part 15 Statement on page 260](#)
- [Nonregulatory Environmental Standards on page 261](#)

Canada

This Class A digital apparatus complies with Canadian ICES-003.

Cet appareil numérique de la classe A est conforme à la norme NMB-003 du Canada.

The Industry Canada label identifies certified equipment. This certification means that the equipment meets certain telecommunications network protective, operational, and safety requirements. Industry Canada does not guarantee the equipment will operate to the users' satisfaction.

Before installing this equipment, users should ensure that it is permissible to connect the equipment to the facilities of the local telecommunications company. The equipment must also be installed using an acceptable method of connection. In some cases, the

inside wiring associated with a single line individual service can be extended by means of a certified connector assembly. The customer should be aware that compliance with the above conditions might not prevent degradation of service in some situations.

Repairs to certified equipment should be made by an authorized Canadian maintenance facility designated by the supplier. Any repairs or alterations made by the user to this equipment, or equipment malfunctions, might give the telecommunications company cause to request the user to disconnect the equipment.



CAUTION: Users should not attempt to make electrical ground connections by themselves, but should contact the appropriate inspection authority or an electrician, as appropriate.

Users should ensure for their own protection that the electrical ground connections of the power utility, telephone lines, and internal metallic water pipe system, if present, are connected together. This precaution might be particularly important in rural areas.

European Community

This is a Class A device. In a domestic environment this device might cause radio interference, in which case the user needs to take adequate measures.

Israel

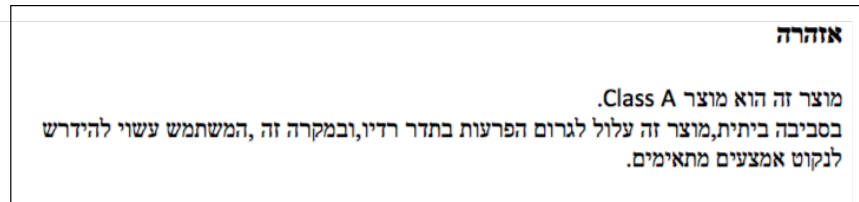

Translation from Hebrew—Warning: This product is Class A. In residential environments, the product may cause radio interference, and in such a situation, the user may be required to take adequate measures.

Japan

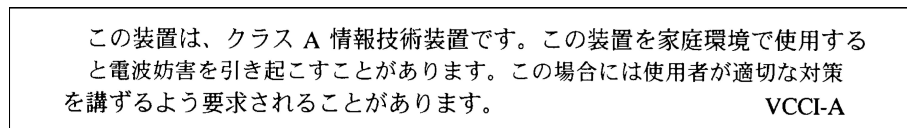

The preceding translates as follows:

This is a Class A device. In a domestic environment this device might cause radio interference, in which case the user needs to take adequate measures.

VCCI-A

Korea

이 기기는 업무용(A급) 전자파적합기기로서 판매자 또는 사용자는 이 점을 주의하시기 바라며, 가정외의 지역에서 사용하는 것을 목적으로 합니다.

Korean Class A Warning 9040913

The preceding translates as follows:

This equipment is Industrial (Class A) electromagnetic wave suitability equipment and seller or user should take notice of it, and this equipment is to be used in the places except for home

United States

The device has been tested and found to comply with the limits for a Class A digital device, pursuant to Part 15 of the FCC Rules. These limits are designed to provide reasonable protection against harmful interference when the equipment is operated in a commercial environment. This equipment generates, uses, and can radiate radio frequency energy and, if not installed and used in accordance with the instruction manual, might cause harmful interference to radio communications. Operation of this equipment in a residential area is likely to cause harmful interference, in which case users need to correct the interference at their own expense.

FCC Part 15 Statement

This equipment has been tested and found to comply with the limits for a Class A digital device pursuant to Part 15 of the FCC Rules. These limits are designed to provide reasonable protection against harmful interference in a residential installation. This equipment generates, uses, and can radiate radio frequency energy and, if not installed and used in accordance with the instructions, might cause harmful interference to radio communications. However, there is no guarantee that interference will not occur in a particular installation.

If this equipment does cause harmful interference to radio or television reception, which can be determined by turning the equipment off and on, the user is encouraged to try and correct the interference by one or more of the following measures:

- Reorient or relocate the receiving antenna.
- Increase the separation between the equipment and the receiver.
- Connect the equipment into an outlet on a circuit different from that to which the receiver is connected.
- Consult the dealer or an experienced radio or TV technician for help.

Nonregulatory Environmental Standards

NEBS compliance—These EX Series switches are Network Equipment Building System (NEBS) compliant:

- EX2200-24T and EX2200-48T
- EX3200-24T, EX3200-48T
- EX3300-24T, EX3300-48T
- EX3400
- EX4200-24T, EX4200-24F, EX4200-24F-S, EX4200-48T and EX4200-48T-S
- EX4300-24T, EX4300-24T-S, EX4300-24P, EX4300-24P-S, EX4300-32F, EX4300-32F-S, EX4300-48T, EX4300-48T-AFI, EX4300-48T-S, EX4300-48P, and EX4300-48P-S
- All EX4500 switches with AC power supplies
- EX4550-32T-AFO, EX4550-32T-AFI, EX4550-32F-AFO, EX4550-32F-AFI, and EX4550-32F-S
- EX4600-40F and EX4600-40F-S
- All EX6200 switches



NOTE: For the EX6200-48P line cards, the intrabuilding ports must use shielded intrabuilding cabling or wiring that is grounded at both ends.

- All EX8200 switches

These switches meet the following NEBS compliance standards:

- SR-3580 NEBS Criteria Levels (Level 4 Compliance)
- GR-1089-CORE: EMC and Electrical Safety for Network Telecommunications Equipment
- GR-63-CORE: NEBS, Physical Protection
 - The equipment is suitable for installation as part of the Common Bonding Network (CBN).
 - The equipment is suitable for installation in locations where the National Electrical Code (NEC) applies.
 - The battery return connection is to be treated as an Isolated DC return (DC-I), as defined in GR-1089-CORE.

Related Documentation

- [Agency Approvals for EX Series Switches on page 257](#)
- [Compliance Statements for Acoustic Noise for EX Series Switches on page 262](#)

Compliance Statements for Acoustic Noise for EX Series Switches

This topic applies to hardware devices in the EX Series product family, which includes EX Series switches, the EX Series Redundant Power System (RPS), and the XRE200 External Routing Engine.

Maschinenlärminformations-Verordnung - 3. GPSGV, der höchste Schalldruckpegel beträgt 70 dB(A) oder weniger gemäss EN ISO 7779

Translation:

The emitted sound pressure is below 70 dB(A) per EN ISO 7779.

**Related
Documentation**

- [Agency Approvals for EX Series Switches on page 257](#)
- [Compliance Statements for EMC Requirements for EX Series Switches on page 258](#)