

Europe, Middle East

ENGLISH

FRANÇAIS

DEUTSCH

NEDERLANDS

ITALIANO

ESPAÑOL

PORTUGUÊS

РУССКИЙ

ČESTINA

TÜRKÇE

POLSKI

SVENSKA

SUOMI

SLOVENCINA

MAGYAR

עברית

العربية

North America/

Norteamérica

ENGLISH

FRANÇAIS

ESPAÑOL

Latin America/

América Latina

ENGLISH

ESPAÑOL

PORTUGUÊS

Asia Pacific

日本語

简体中文

繁體中文

한국어

ENGLISH

THRUSTMASTER®

FERRARI 488 GT3 WHEEL ADD-ON

THRUSTMASTER®

FERRARI 488 GT3 WHEEL ADD-ON

PC (Windows 10/11)

PS4™ / PS5™

Xbox Series / Xbox One

User Manual



Carefully read the instructions provided in this manual **before** installing the product, **before** any use of the product and **before** any maintenance. Be sure to follow the safety instructions. Failure to follow these instructions may result in accidents and/or damage. Keep this manual so that you can refer to the instructions in the future.

TABLE OF CONTENTS

1. BOX CONTENTS	5
2. FEATURES	6
3. INFORMATION REGARDING USE OF THE WHEEL	8
4. INSTALLATION OF THE QUICK RELEASE HOLDER	13
<i>Installation of the quick release holder for latch base</i>	<i>14</i>
<i>Installation of the quick release holder for screw base</i>	<i>17</i>
5. MAPPING	21
<i>Mapping for PC</i>	<i>21</i>
<i>Mapping for PS4™/PS5™</i>	<i>22</i>
<i>Mapping for Xbox Series/Xbox One</i>	<i>23</i>
6. LED OPERATION	24
<i>How to enter/exit the LED menu</i>	<i>25</i>
<i>How to adjust the LED intensity</i>	<i>27</i>
<i>How to change the LED mode: GT3 or Formula</i>	<i>28</i>

7. CUSTOMIZATION OF THE PADDLE

SHIFTERS29

How to adjust the paddle shifter spacing...31

How to adjust the paddle shifter reach.....33

*How to adjust the magnetic sensitivity and
the sound level of the paddle shifters35*

8. FAQ AND TECHNICAL SUPPORT.....37



FERRARI 488 GT3 WHEEL ADD-ON

Be part of the legend of GT racing with Ferrari 488 GT3 Wheel Add-On, a wheel designed for performance, and compatible with all Thrustmaster wheel bases.

This manual will help you install and use your Ferrari 488 GT3 Wheel Add-On under the best conditions. Before getting started racing, carefully read the instructions and the warnings: they will help you get the most enjoyment out of your product.



1. Box contents

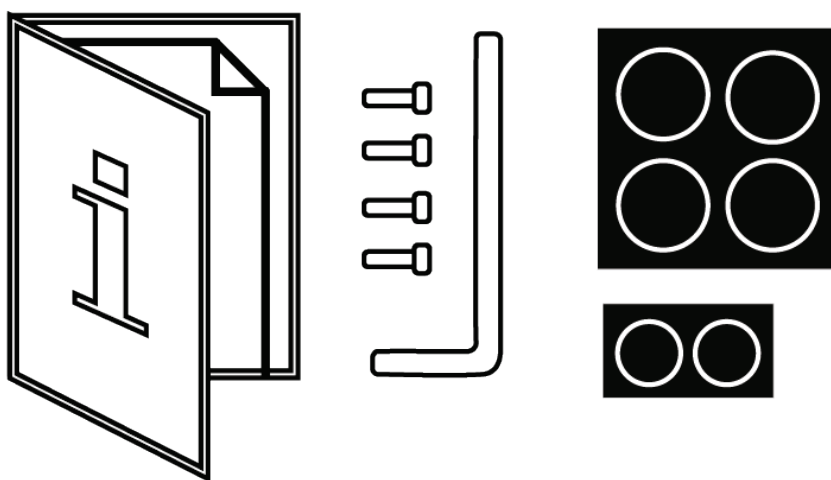
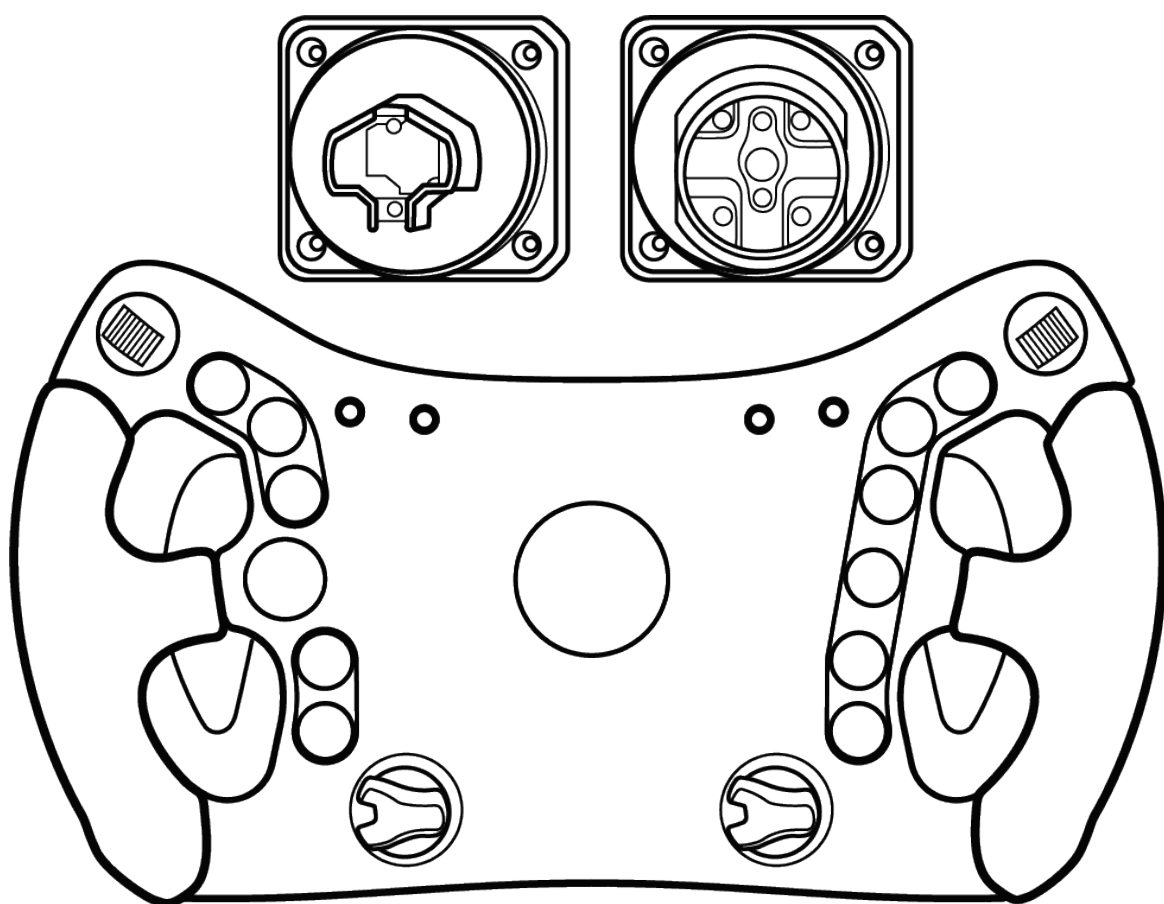



2. Features

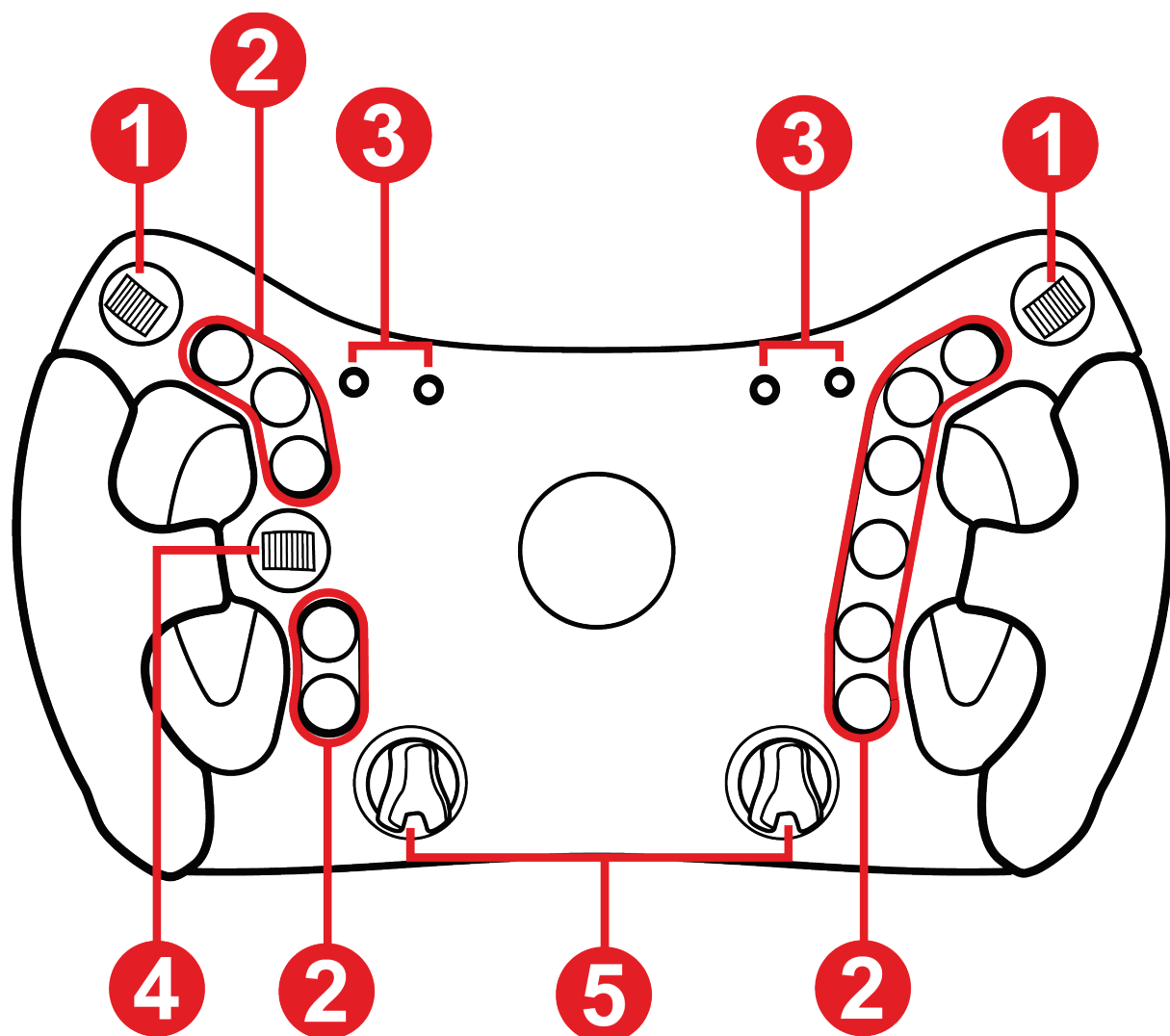

- ❶ Thumb encoders
- ❷ 11 action buttons
- ❸ RPM LEDs and race data (flags, pits)
- ❹ D-pad
- ❺ Rotary encoders

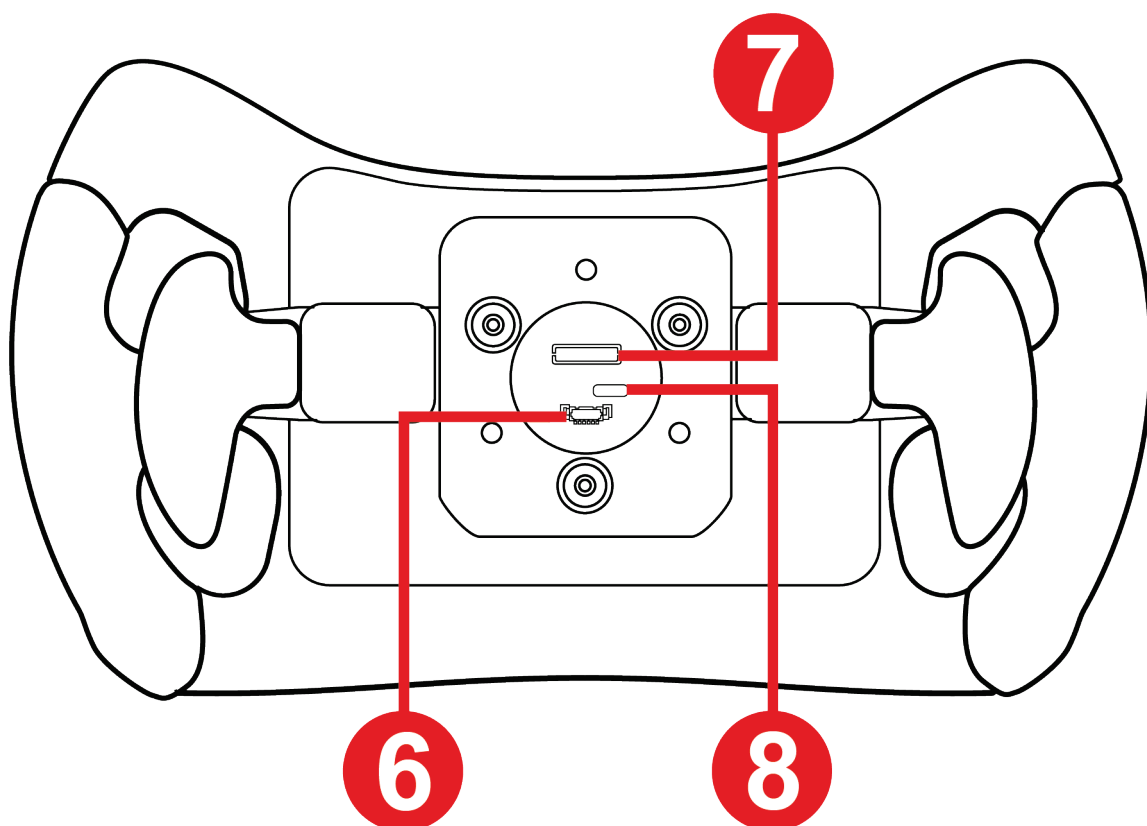

⑥ Connection port for quick release holder for screw base

⑦ Connection port for quick release holder for latch base

⑧ USB-C port (if a firmware update is required – cable not included)

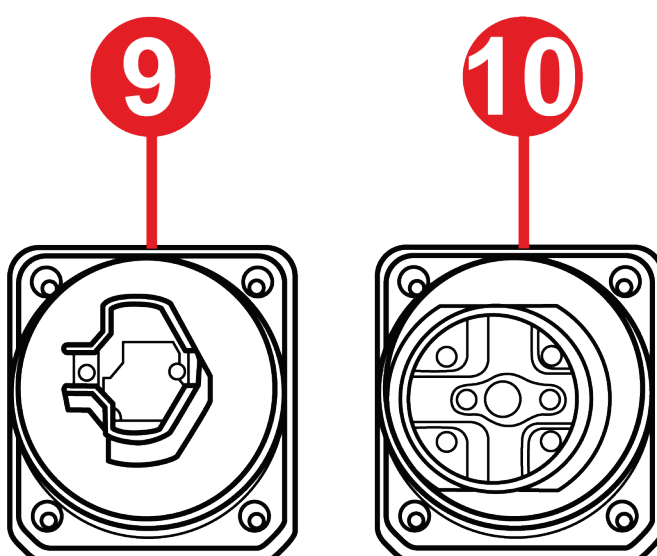

⑨ Quick release holder for latch base

⑩ Quick release holder for screw base



3. Information regarding use of the wheel



Documentation

Before using this product, carefully read this documentation again, and keep it for future reference.



Electrical shock

- Keep the product in a dry location and do not expose it to dust or sunlight.
- Do not twist or pull on the connectors and cables.
- Follow the connection directions.
- Do not spill any liquid on the product or its connectors.
- Do not short-circuit the product.
- Never dismantle the product (except in the cases of customization specified in this manual); do not throw it onto a fire and do not expose it to high temperatures.
- Do not open up the device: there are no user-serviceable parts inside. Any repairs must be carried out by the manufacturer, a specified agency or a qualified technician.



Securing the gaming area

- Do not place any object in the gaming area which may disrupt the practice of the user, or which may provoke an inappropriate movement or an interruption by another person (coffee cup, telephone, keys, for example).
- Do not cover the power cables with a carpet or rug, blanket or covering or any other item, and do not place any cables where people will be walking.



Injuries due to Force Feedback and repeated movements

Using a Force Feedback racing wheel may cause muscle or joint pain. To avoid any problems:

- Warm up beforehand, and avoid lengthy periods of practice.
- Take a 10 to 15-minute break after each hour of practice.
- If you feel any fatigue or pain in your hands, wrists, arms, feet or legs, press the button to turn off Force Feedback, power off the base and rest for a few hours before you start practicing again.
- If the symptoms or pains indicated above persist when you start practicing again, stop practicing and consult your doctor.
- Do not set the Force Feedback at a level that is too high in relation to your expertise and your physical condition.
- Keep the device out of the reach of people less than 16 years of age.
- Make sure that the base and the wheel are properly attached, as per the manual's instructions.



Risk of unforeseen, powerful and rapid rotations: never place a hand or an arm through the openings in the wheel rim, or in the wheel's trajectory of rotation.



When using the product, always leave both hands correctly positioned on the wheel without ever completely letting go.



Product to be handled only by people **16 years of age or older.**



4. Installation of the quick release holder

Ferrari 488 GT3 Wheel Add-On comes with two quick release holders corresponding to the Thrustmaster base formats.

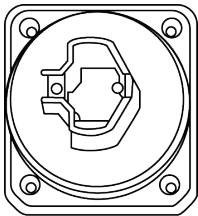
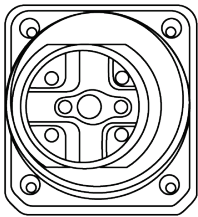
System	Compatibility
 Quick release holder for latch base	T818, T818 Ferrari SF1000 Simulator and future Thrustmaster bases.
 Quick release holder for screw base	T-GT / T-GT II Servo Base, T300 RS Servo Base, TS PC Racer, TS-XW, TX Racing Wheel Servo Base, TS-XW Servo Base.



Before each use, verify that **Ferrari 488 GT3 Wheel Add-On** is still properly attached to the support, as per the manual's instructions for the base.



Installation of the quick release holder for latch base

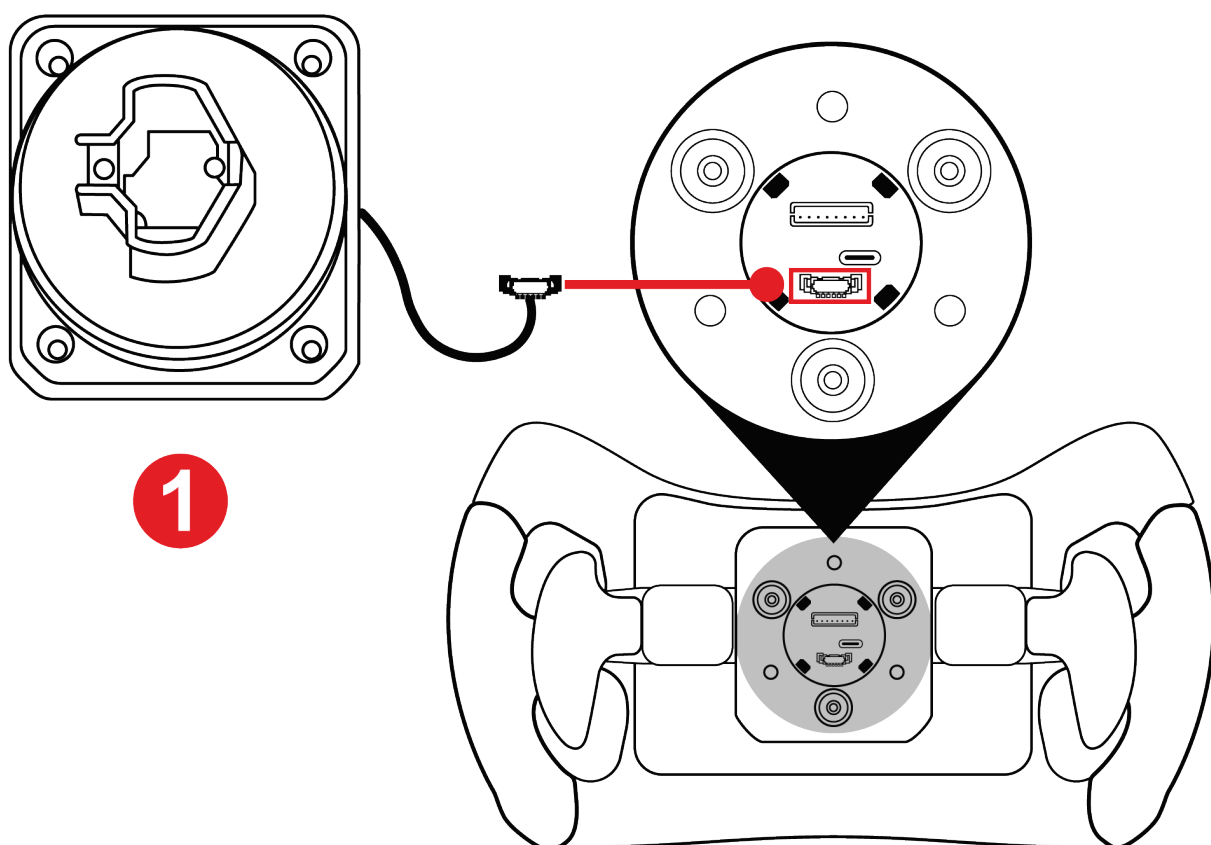

1 Plug the quick release holder connector into the corresponding port on the back of the wheel.



To avoid pinching the cable, retract it into its housing before screwing the holder.

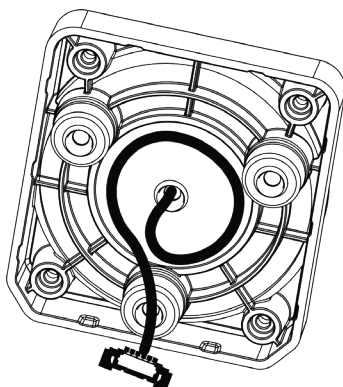

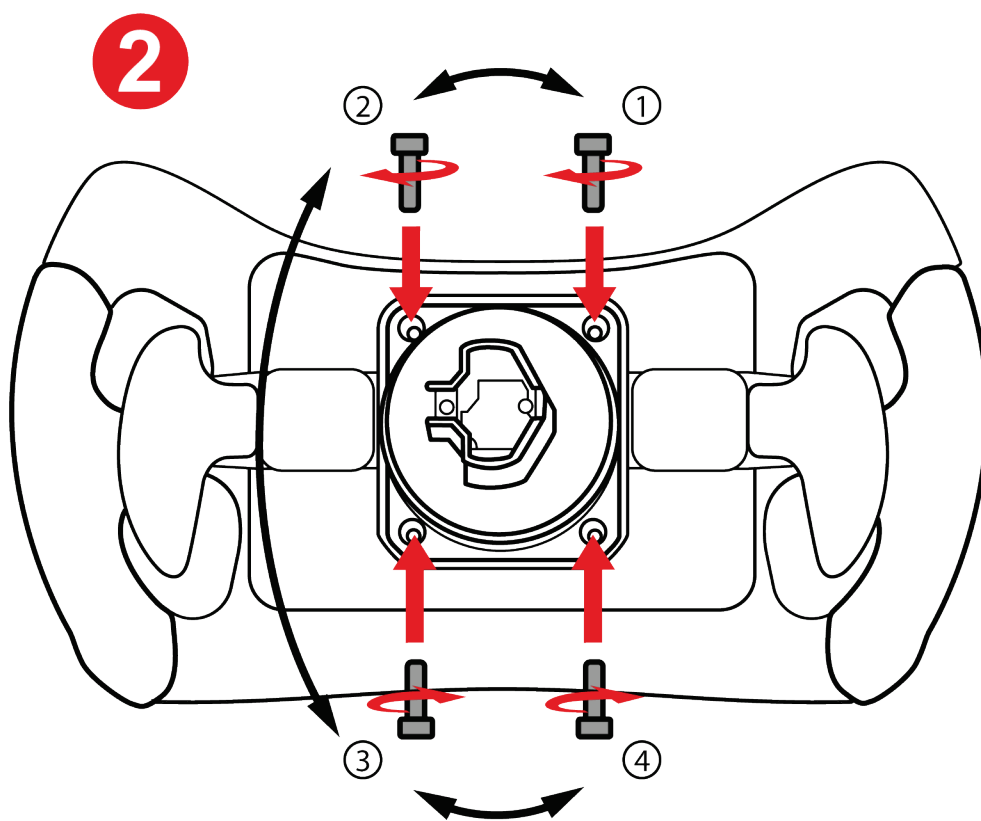

2 Insert the quick release holder and tighten it using the Torx wrench supplied.



When mounting the holder, do not overtighten the screws.

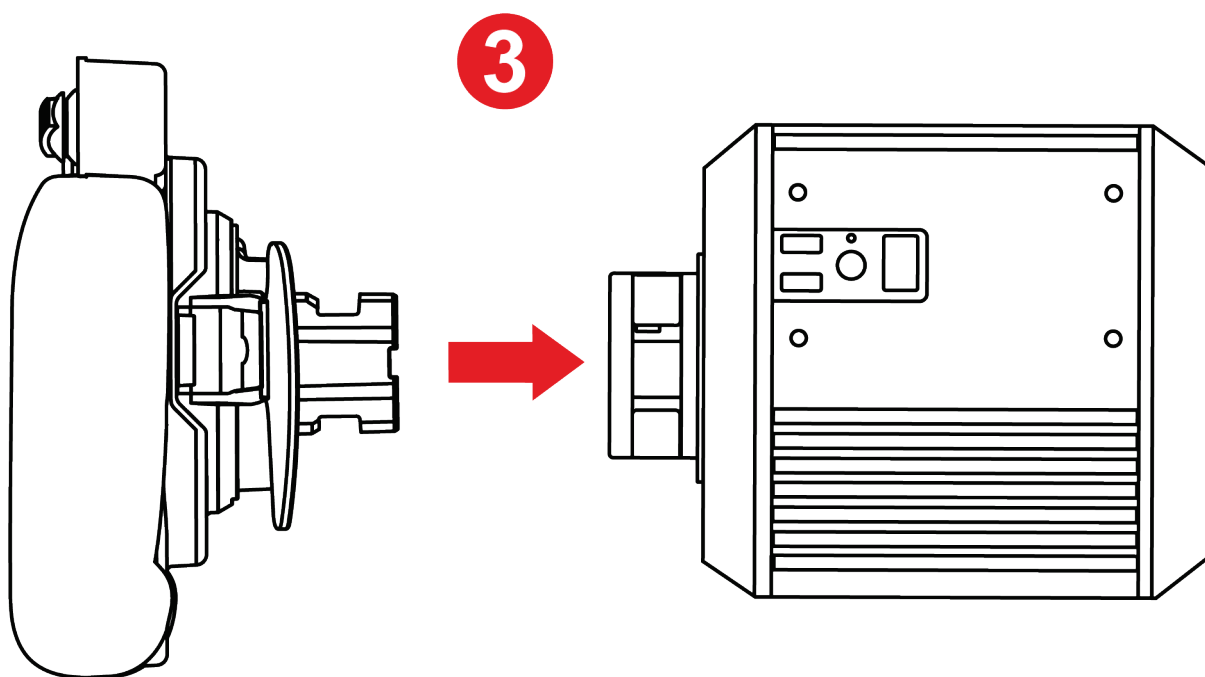

3 Mount the wheel onto the base.



Follow the installation procedure specified in the user manual of the base.



Installation of the quick release holder for screw base

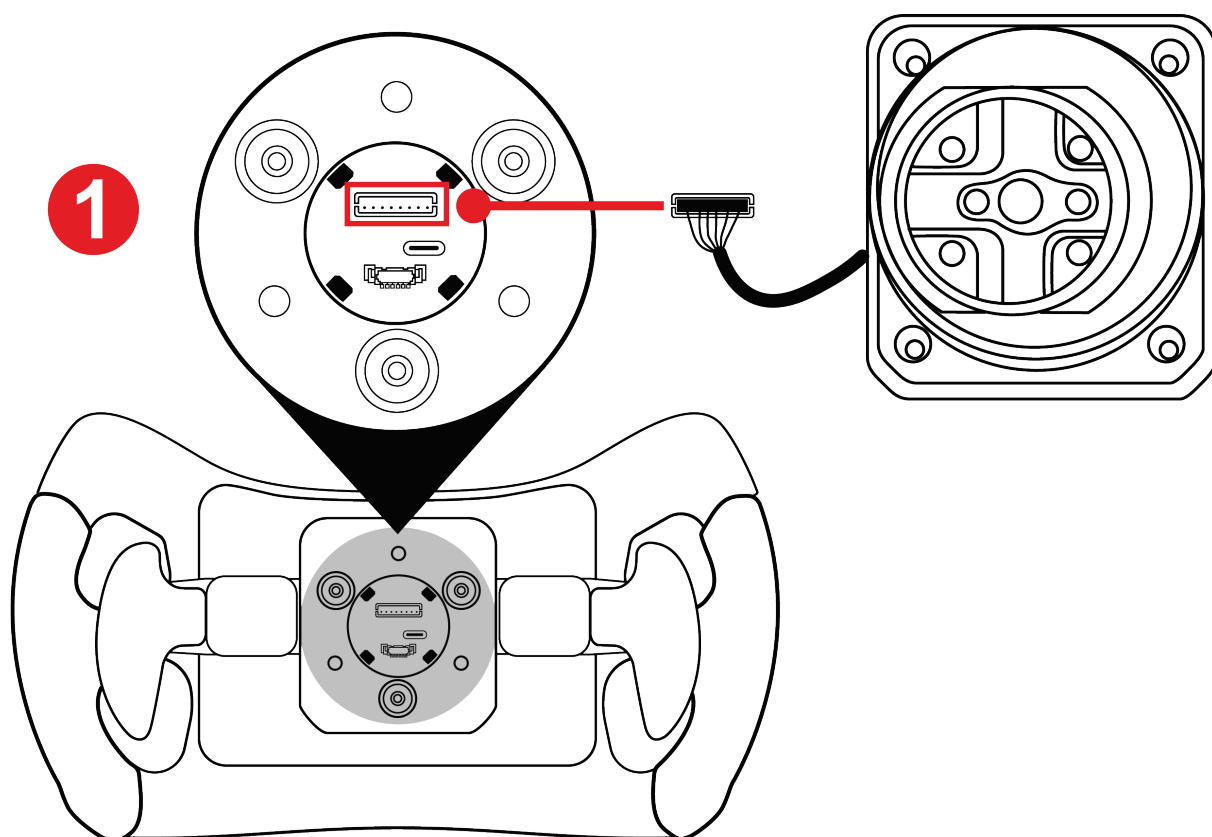

1 Plug the quick release holder connector into the corresponding port on the back of the wheel.



To avoid pinching the cable, retract it into its housing before screwing the holder.

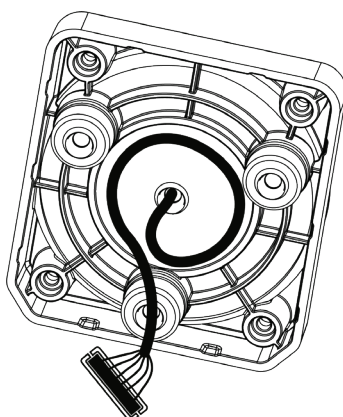

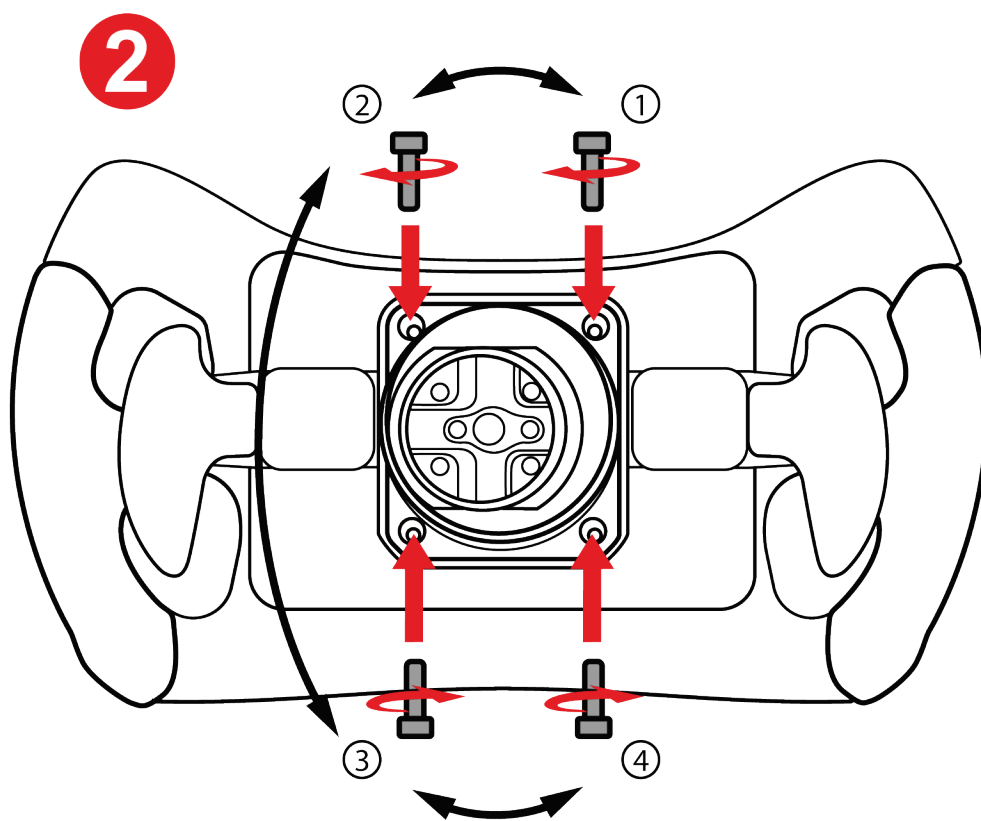

2 Insert the quick release holder and tighten it using the Torx wrench supplied.



When mounting the holder, do not overtighten the screws.

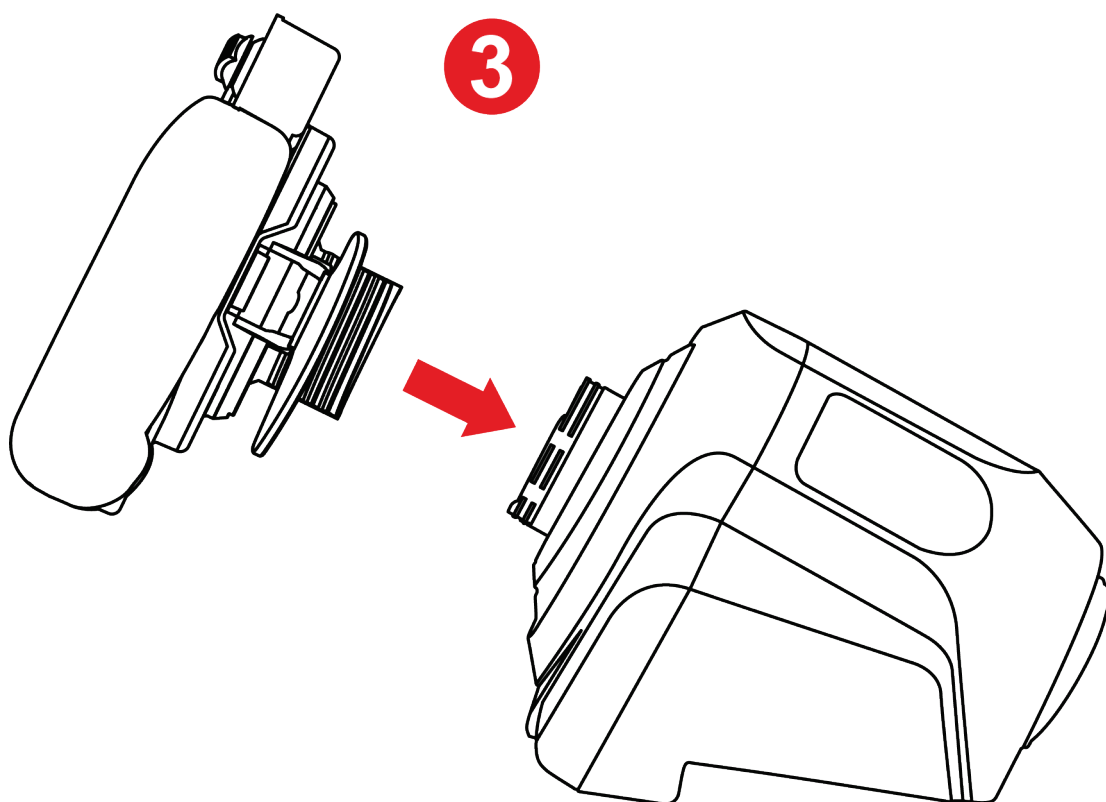

3 Mount the wheel onto the base.



Follow the installation procedure specified in the user manual of the base.



Never connect the Quick Release Adapter (supplied with the T818 base and sold separately) to the quick release holder for screw base if you intend to use it on a T818 base.

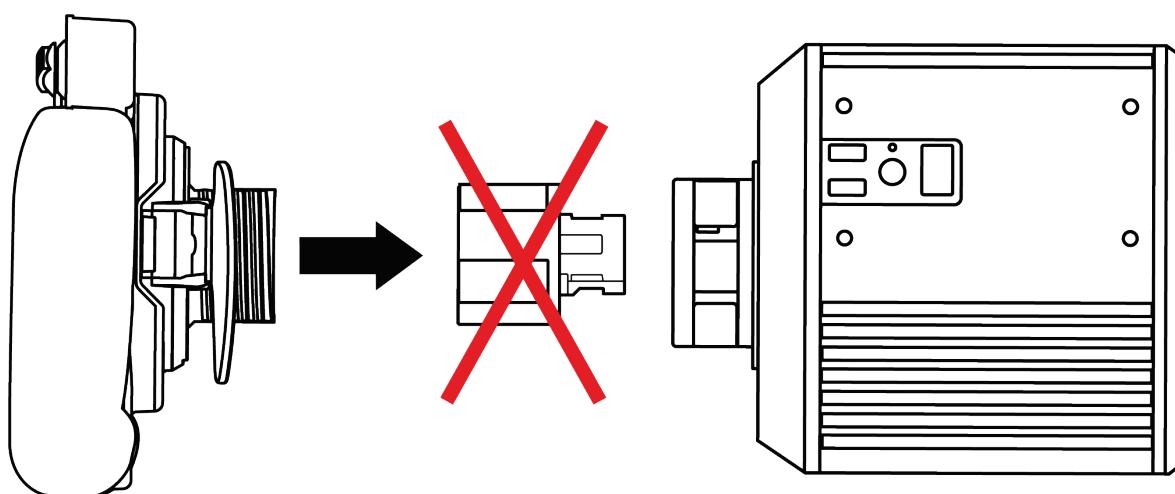
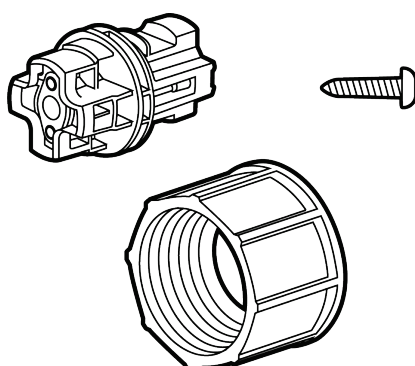

For use on a T818 base or a base equipped with a connector for latch base, use only the **quick release holder for latch base** supplied with **Ferrari 488 GT3 Wheel Add-On**.



5. Mapping

Mapping for PC

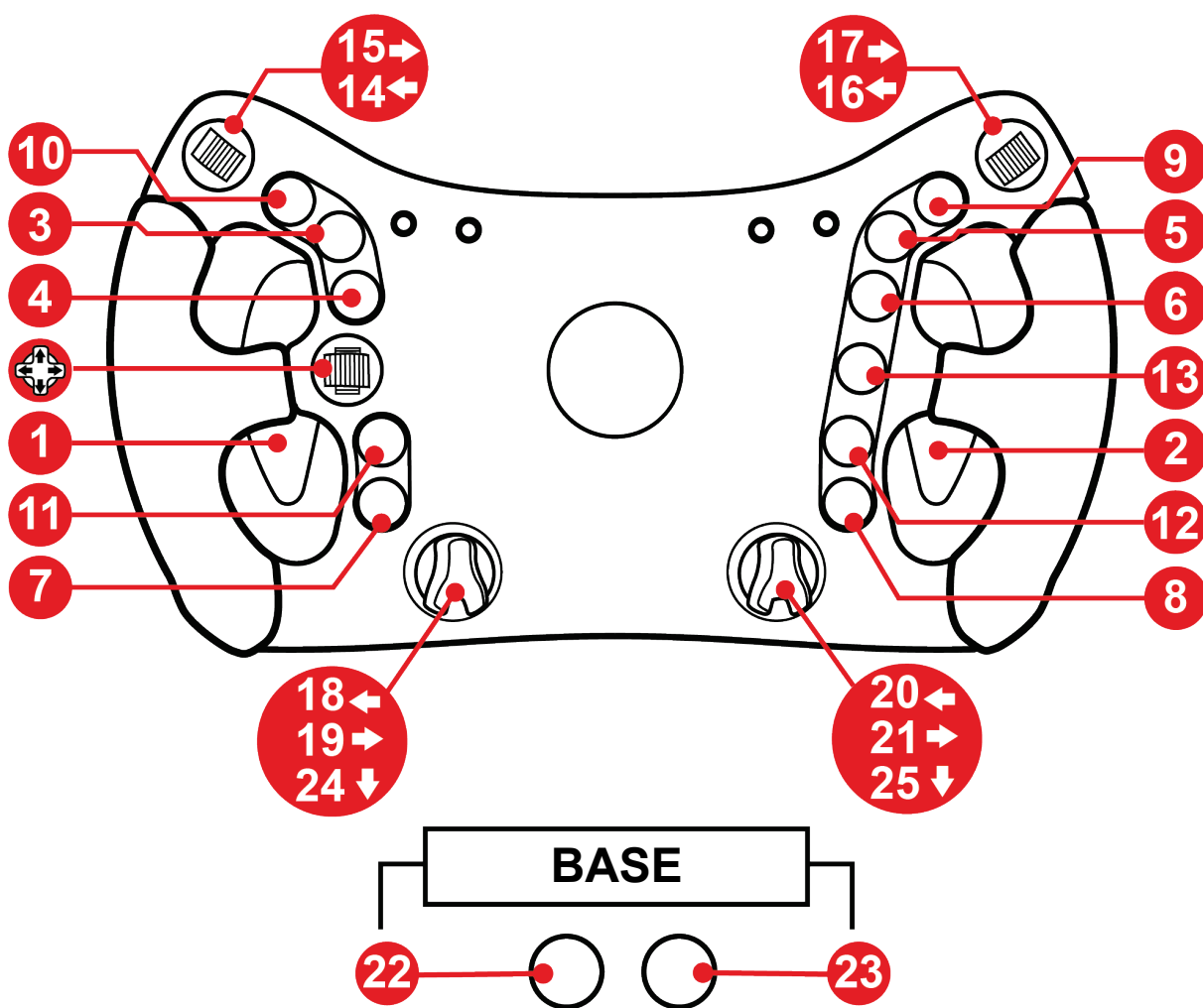



Mapping for PS4™/PS5™

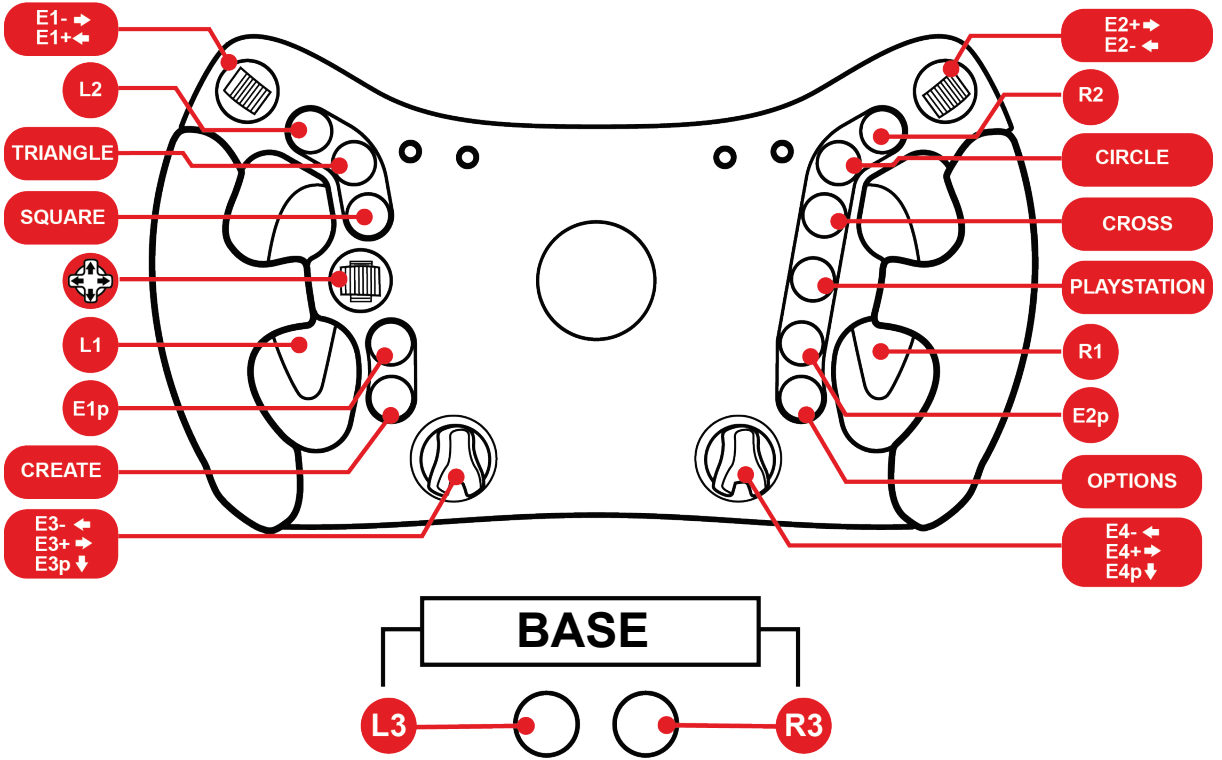



Mapping for Xbox Series/Xbox One

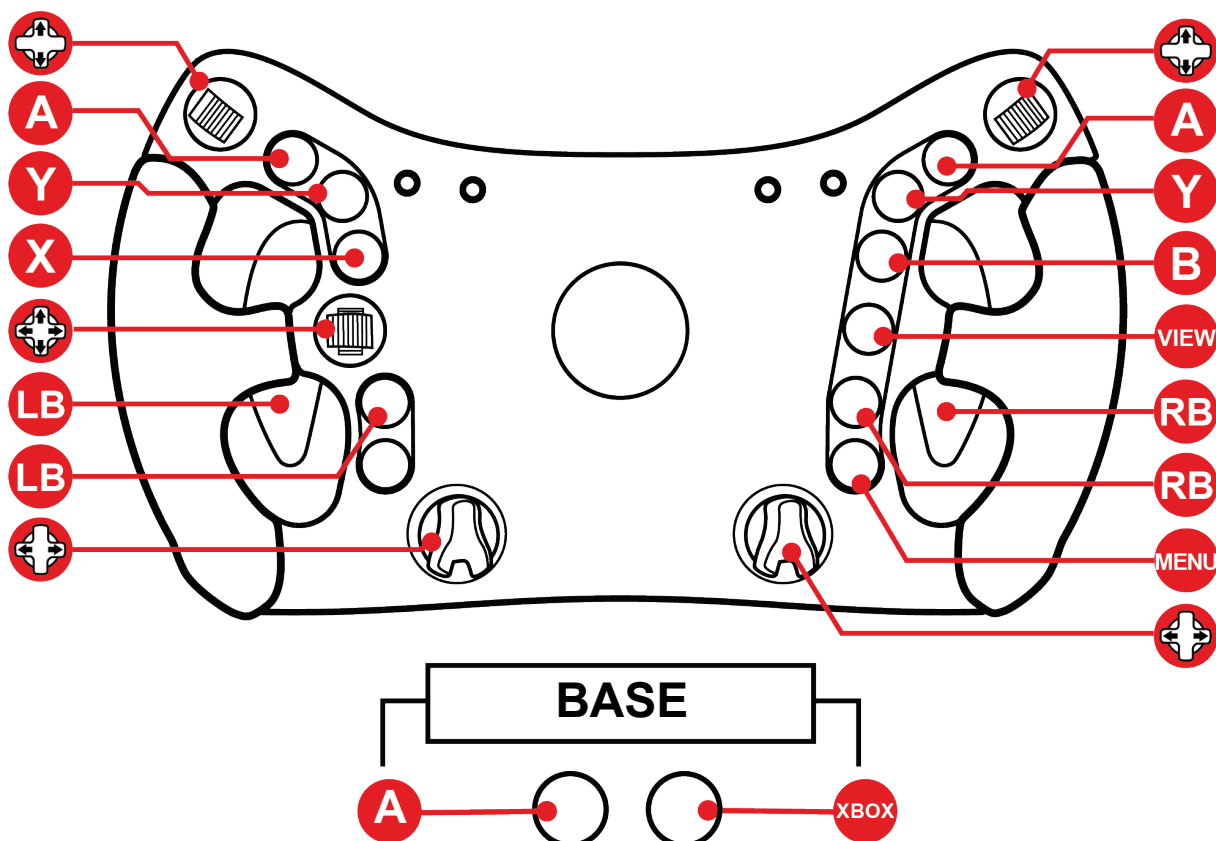

On Xbox Series et Xbox One:

- The LEDs on Ferrari 488 GT3 Wheel Add-On are not functional due to console protocol restrictions.
- Some functions (encoders, number of buttons) are limited by the console protocol.



6. LED operation

Ferrari 488 GT3 Wheel Add-On displays race data via the LEDs: flag, pit and RPM.

The data displayed can be customized (intensity and color of the RPM LEDs), depending on the mode (GT3 or Formula).

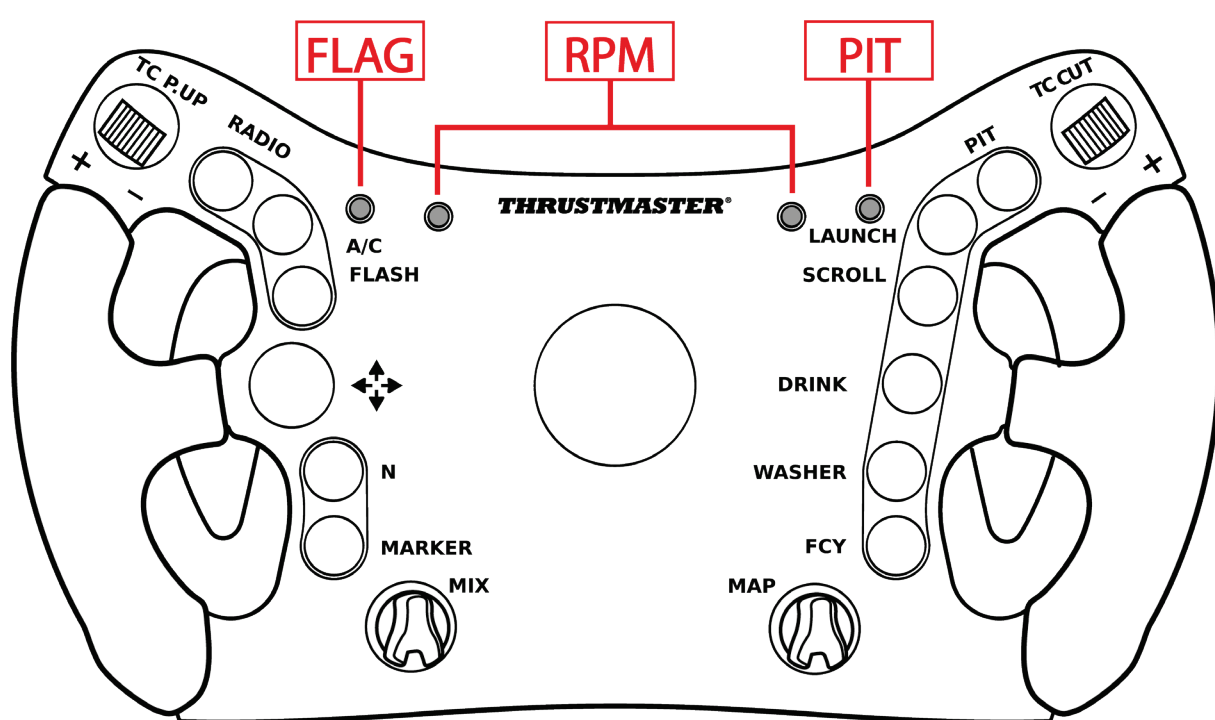

The LEDs are functional on PC and PS4™/PS5™.

On Xbox Series and Xbox One, the LEDs are not functional due to console protocol restrictions.



How to enter/exit the LED menu

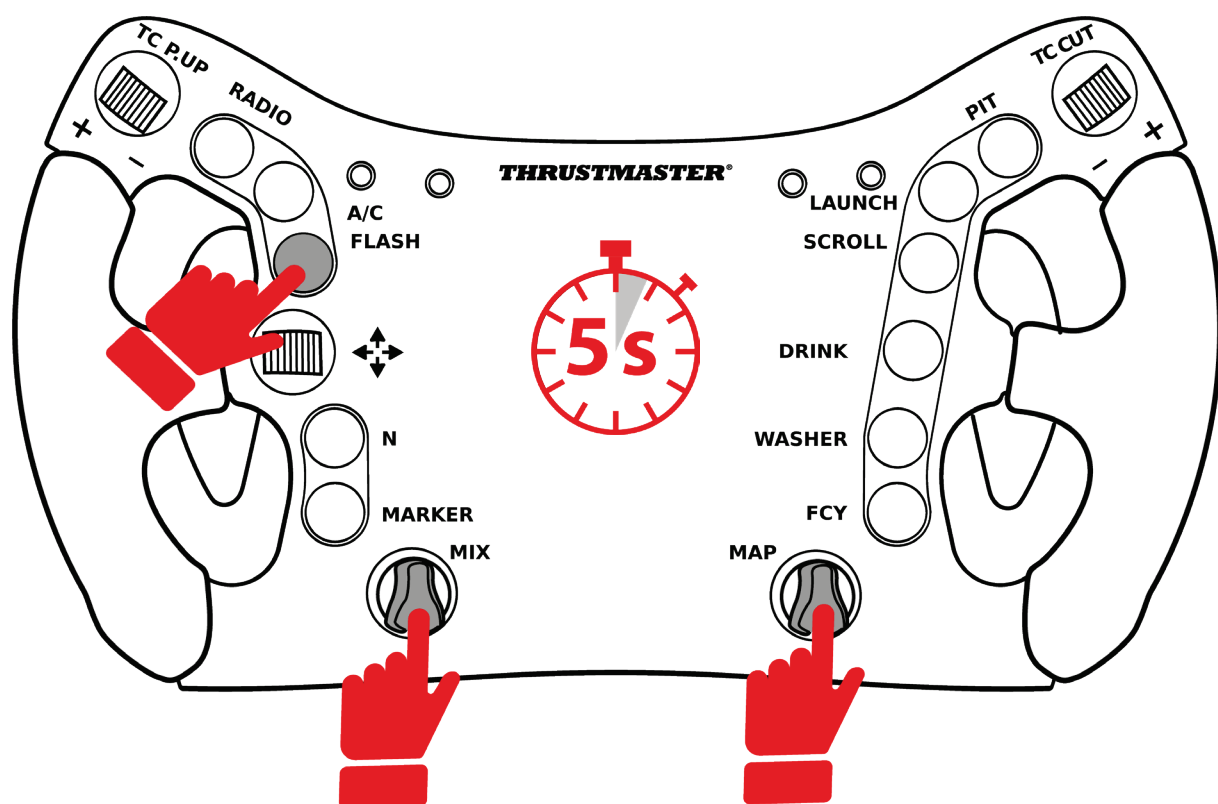

- To enter the LED menu, simultaneously press the **FLASH** button and both **rotary encoders** for **5 seconds**, then release them.

- To exit the LED menu, simultaneously press the **FLASH** button and both **rotary encoders**, then release them.



FLAG

RPM

PIT



Enter the LED menu: the FLAG and PIT LEDs and one of the RPM LEDs (red on the left, or blue on the right) light up.



Exit the LED menu: all four LEDs turn off.



How to adjust the LED intensity

- Enter the LED menu by simultaneously pressing the **FLASH** button and both **rotary encoders** for 5 seconds, then release them.
- Turn the **left encoder (MIX)** to the left to decrease intensity, or to the right to increase intensity.



- Exit the LED menu by simultaneously pressing the **FLASH** button and both **rotary encoders**, then release them.



How to change the LED mode: GT3 or Formula

- Enter the LED menu by simultaneously pressing the **FLASH** button and both **rotary encoders** for **5 seconds**, then release them.
- Turn the **right encoder (MAP)** to the left to select the GT3 mode (red LED), or to the right to select the Formula mode (blue LED).



GT3 mode (default mode)



FORMULA mode

- Exit the LED menu by simultaneously pressing the **FLASH** button and both **rotary encoders**, then release them.



7. Customization of the paddle shifters

The paddle shifters of **Ferrari 488 GT3 Wheel Add-On** are adjustable in **spacing** and **reach**.

Spacing consists in adjusting the paddle shifter in width, which modifies the distance between the grip and the paddle shifter.

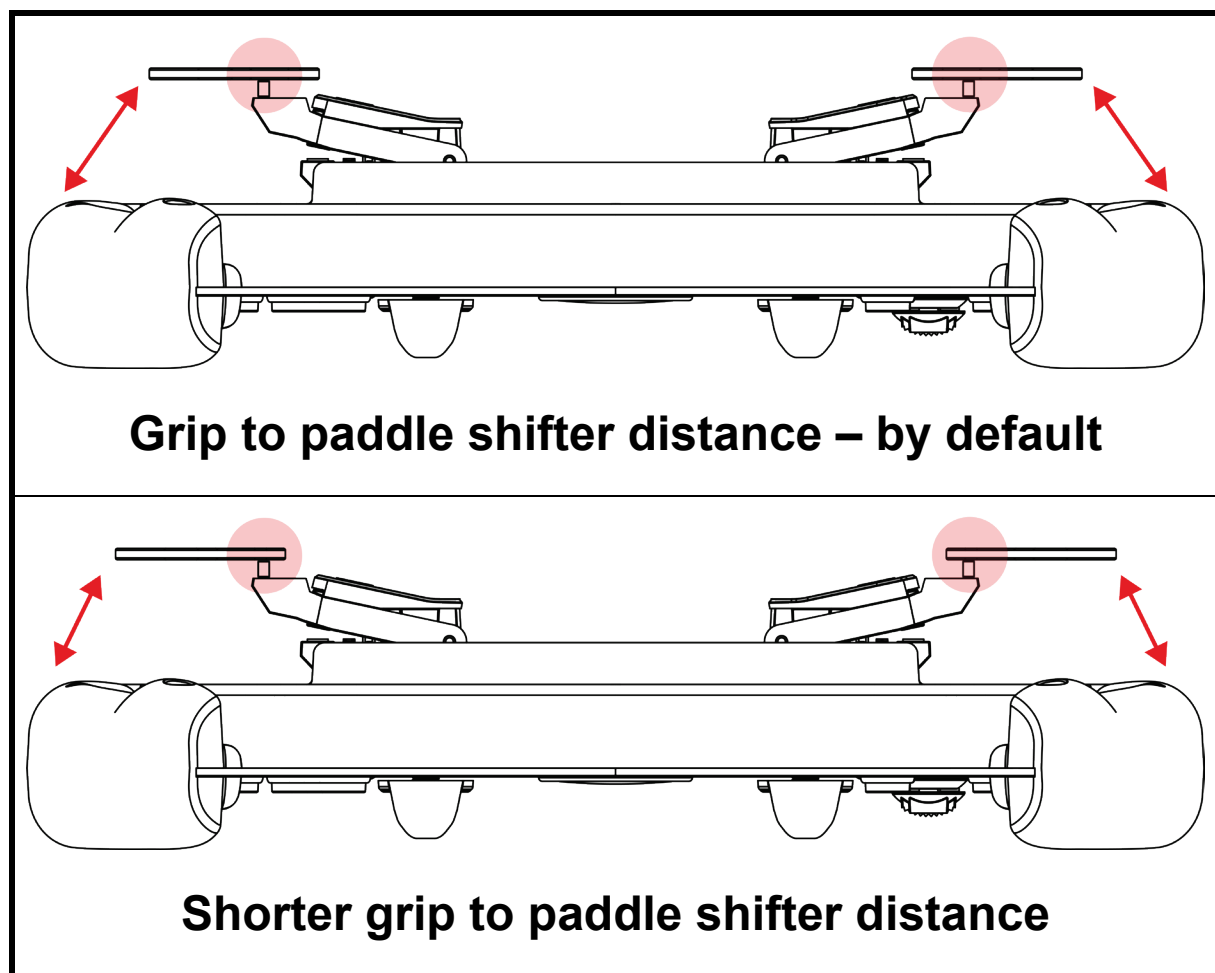



Adjusting the **reach** using the spacers modifies the paddle shifter activation distance.

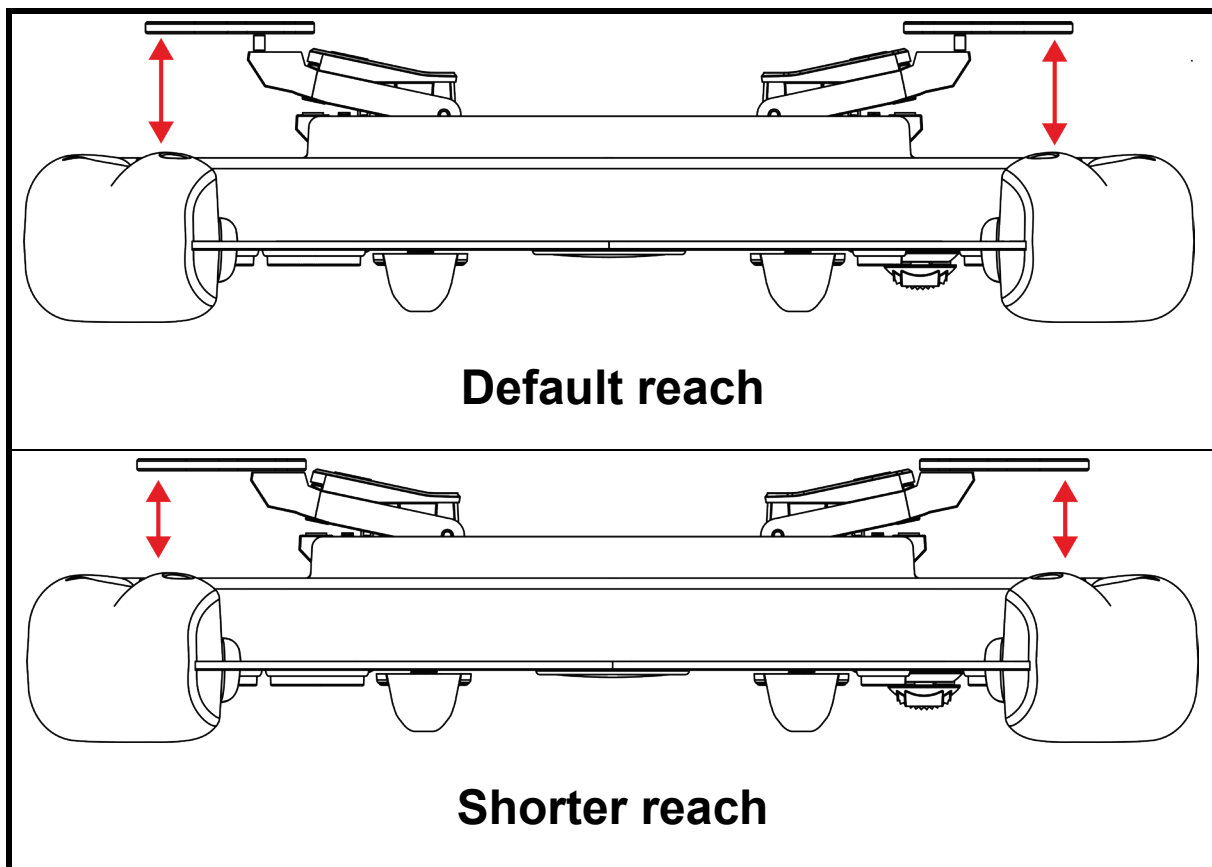

It is also possible to adjust the **magnetic sensitivity** and **sound level** produced by the paddle shifters, using the supplied set of pads.

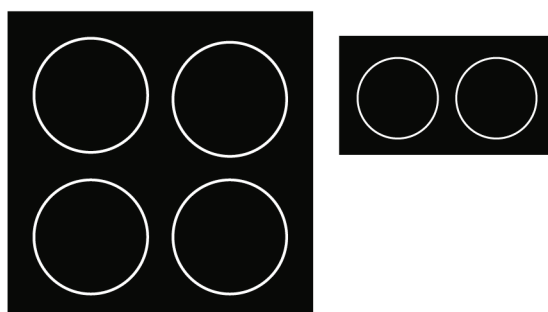



How to adjust the paddle shifter spacing

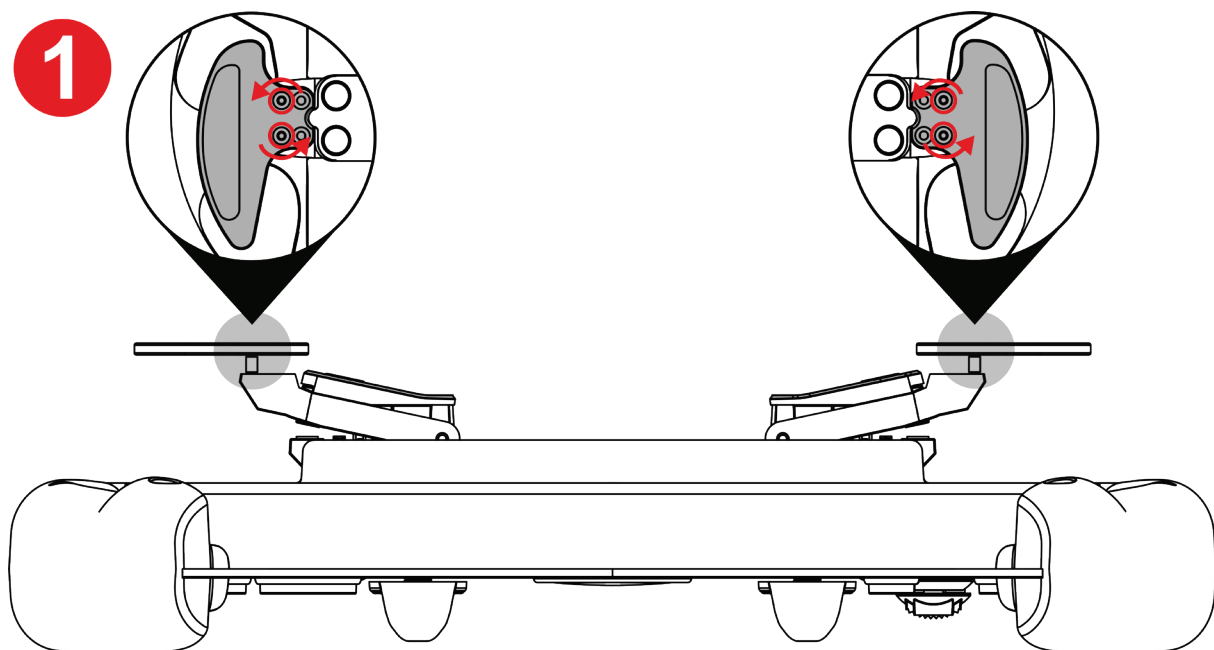

1 Unscrew the four paddle shifter screws using the Torx wrench supplied.

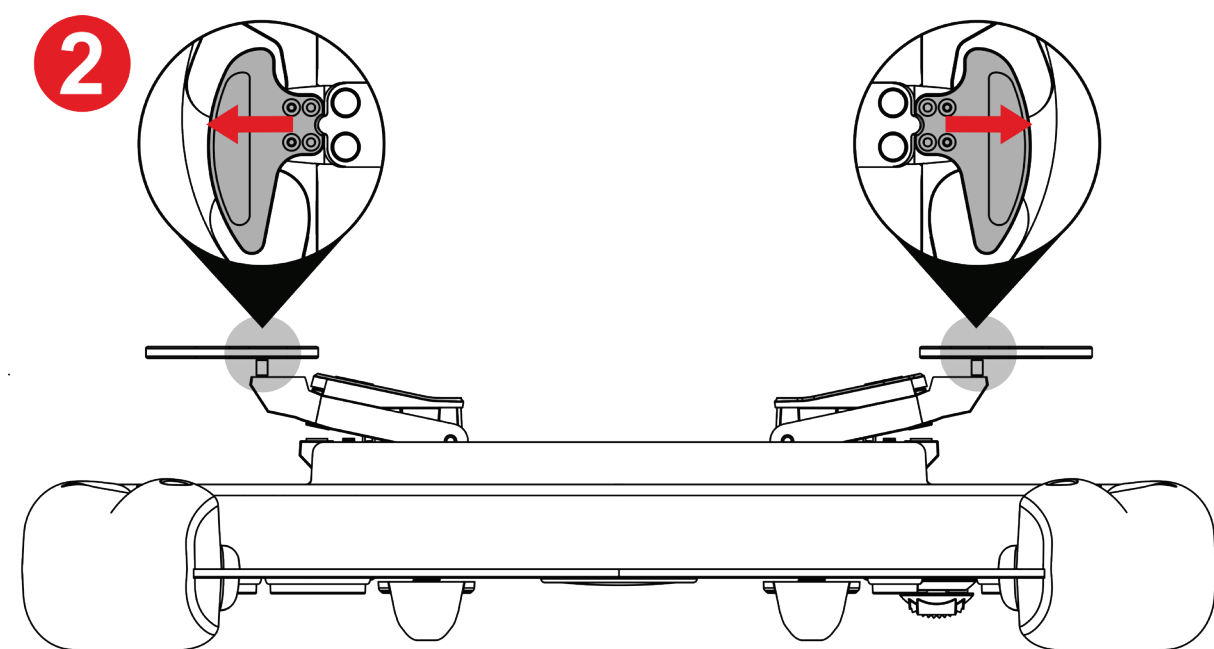

2 Shift the paddle shifters outwards to match the holes.

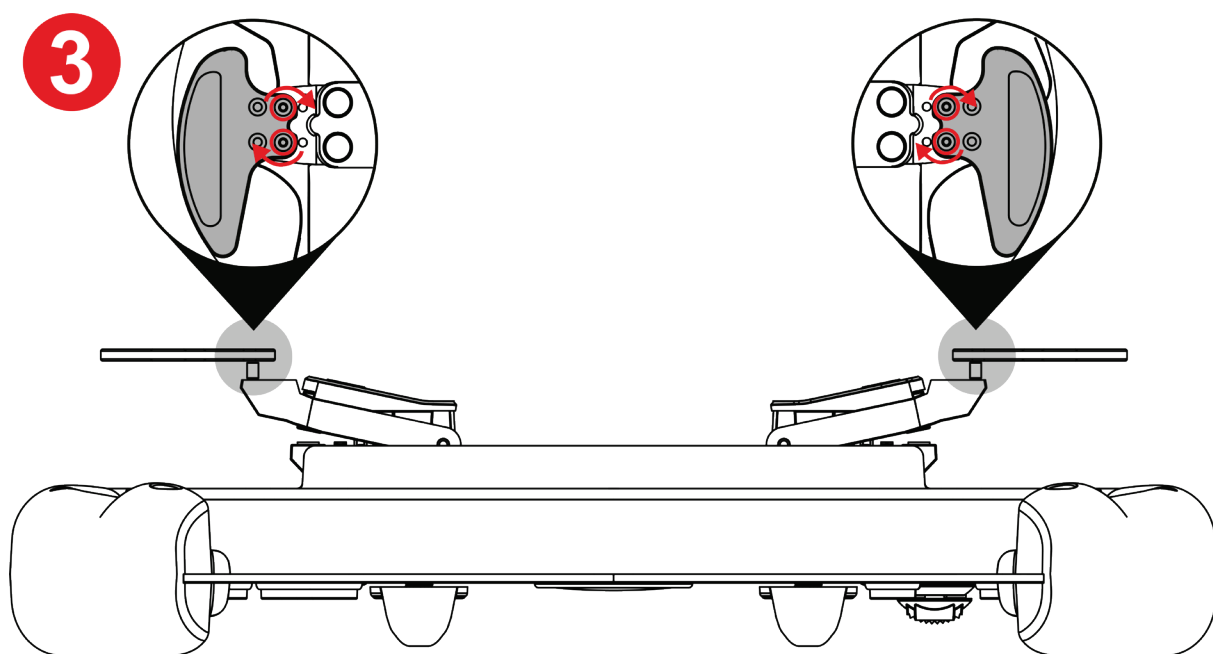

3 Tighten the four paddle shifter screws using the Torx wrench supplied.



How to adjust the paddle shifter reach

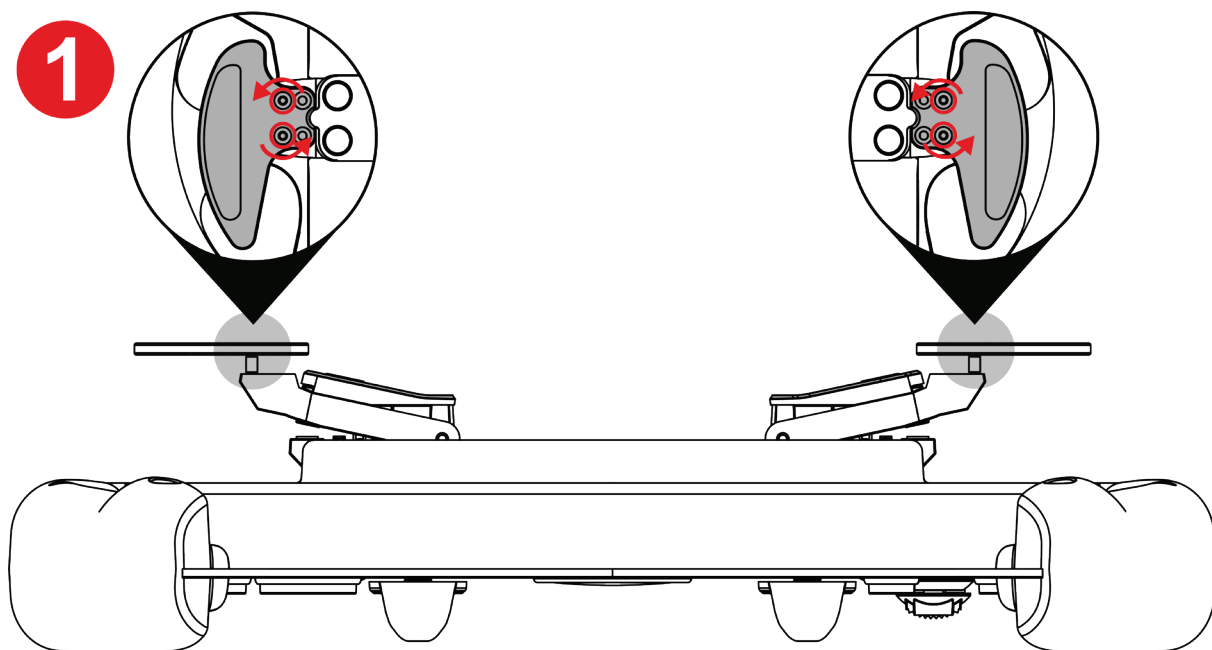

1 Unscrew the four paddle shifter screws using the Torx wrench supplied.

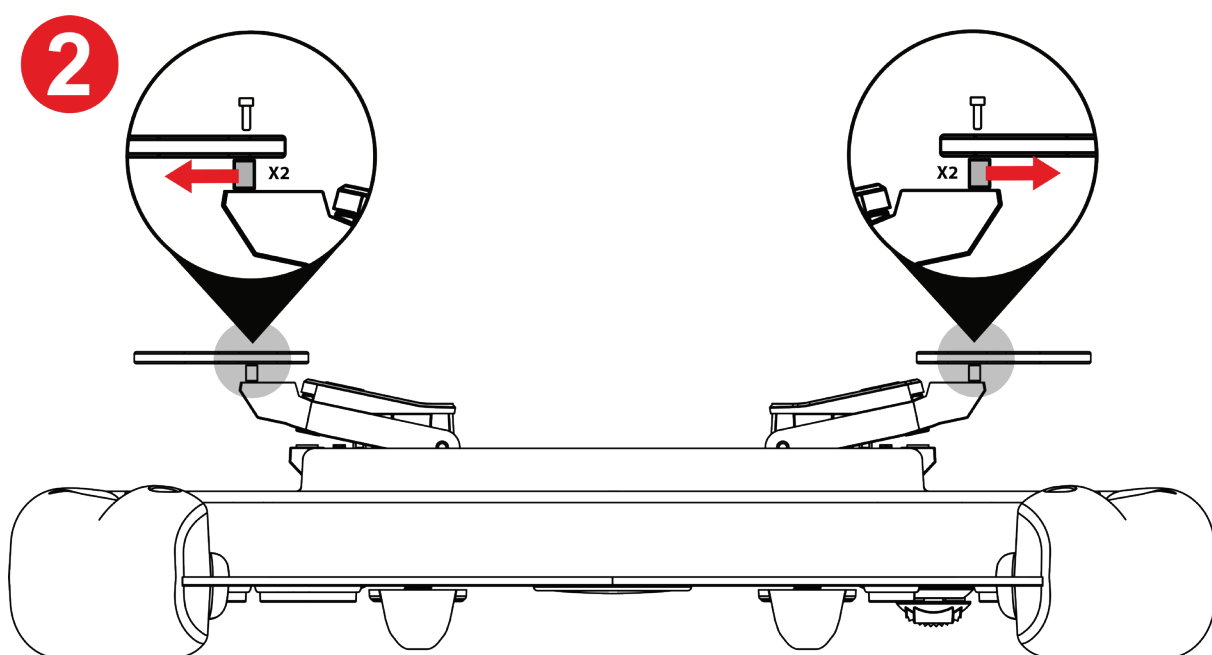

2 Remove the spacers.

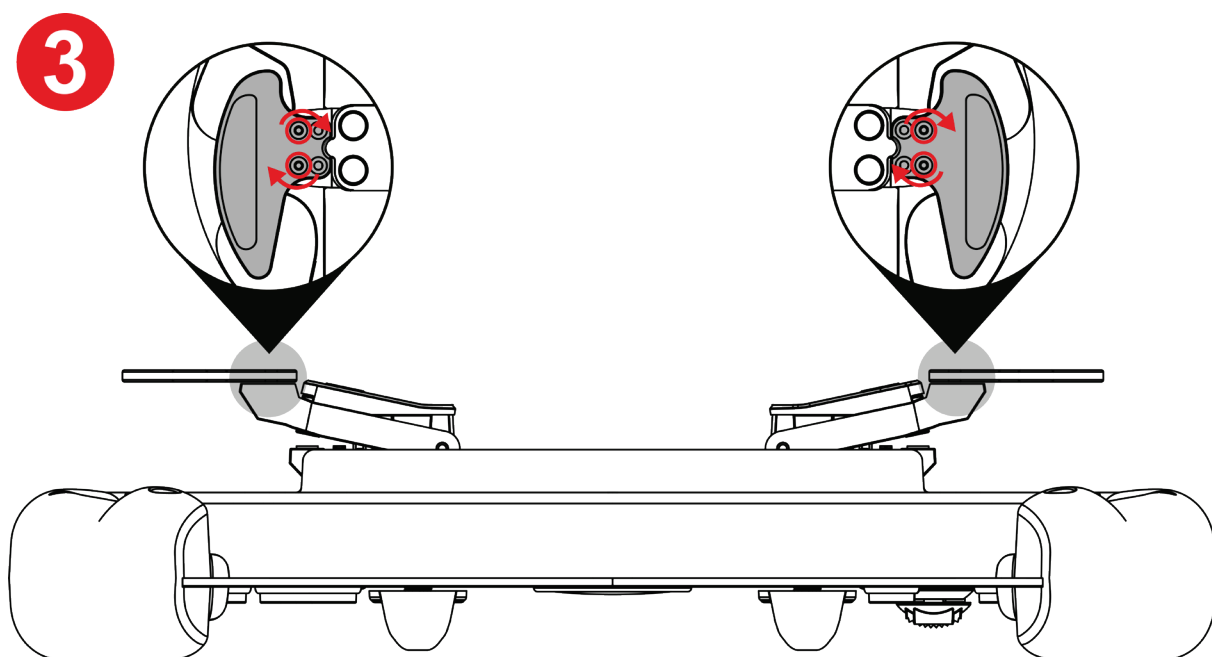

3 Tighten the four paddle shifter screws using the Torx wrench supplied.



How to adjust the magnetic sensitivity and the sound level of the paddle shifters

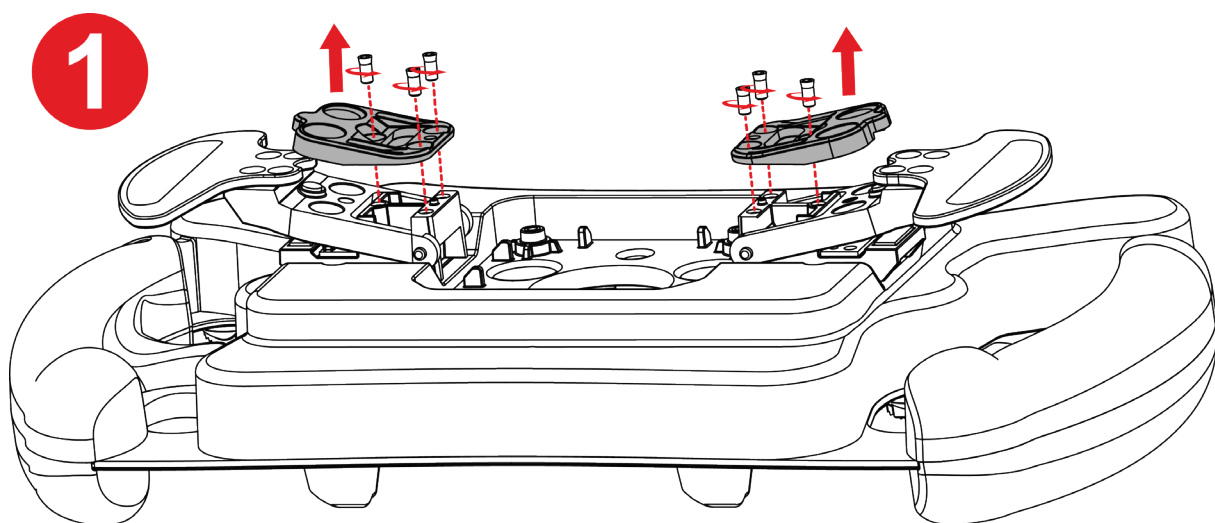

1 Remove the magnetic stops by unscrewing the six stop screws using the Torx key supplied.

2

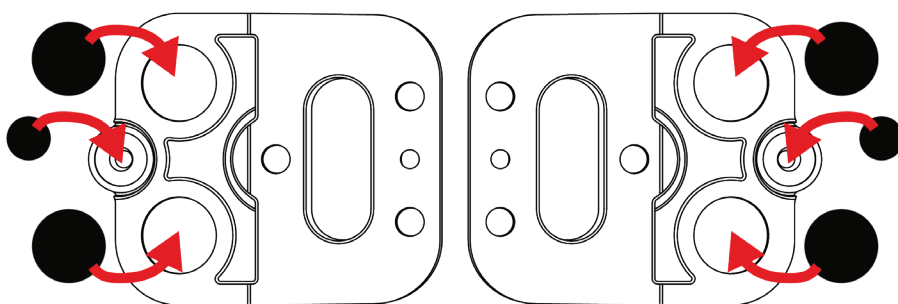
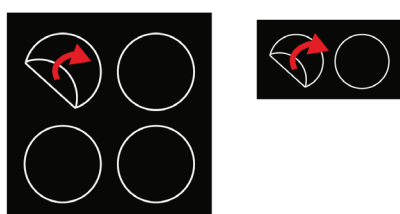

2 Peel off the supplied pads and affix them in the appropriate places underneath the magnetic stops.



Refer to the **Magnetic sensitivity and paddle shifter sound attenuation table** for possible configurations and their effects.





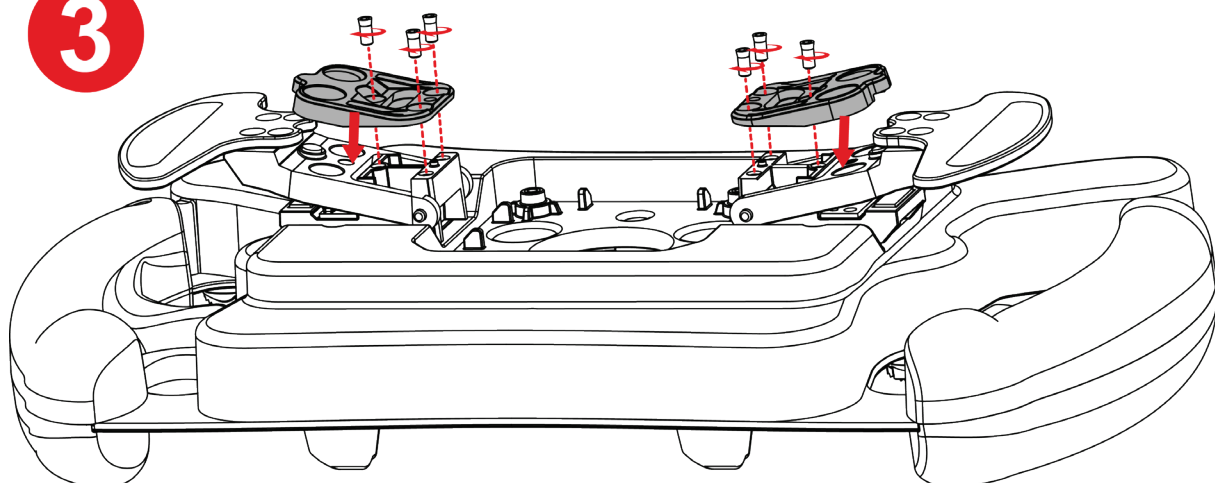

3

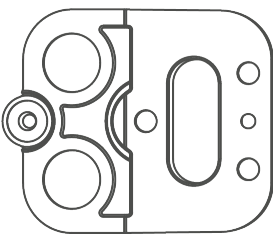
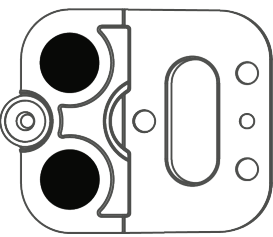
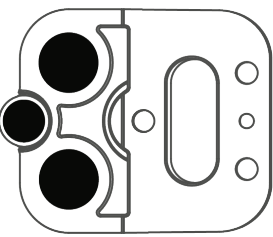

3 Reinstall the magnetic stops and tighten the six stop screws using the Torx wrench supplied.

Magnetic sensitivity and paddle shifter sound attenuation table

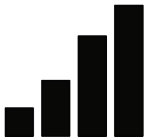
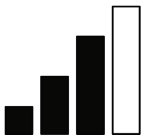
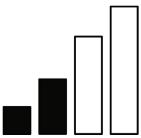
	 (by default)		
Magnetic sensitivity			
Sound			



8. FAQ and technical support

Do you have questions regarding Ferrari 488 GT3 Wheel Add-On, or are you experiencing technical problems? If so, visit the Thrustmaster technical support website:

<https://support.thrustmaster.com/product/ferrarif488gt3addon>.

On this page, you can also update the wheel's firmware.



THRUSTMASTER®



FERRARI 488 GT3 WHEEL ADD-ON



PC (Windows 10/11)

PS4™ / PS5™

Xbox Series / Xbox One

Manuel de l'utilisateur



Lisez attentivement les instructions fournies dans ce manuel **avant** d'installer le produit, **avant** toute utilisation et **avant** tout entretien. Conformez-vous aux consignes de sécurité. Le non-respect de ces instructions peut causer des accidents et/ou des dommages. Conservez ce manuel pour toute consultation ultérieure des instructions.

TABLE DES MATIÈRES

1.	CONTENU DE LA BOITE	5
2.	CARACTERISTIQUES	6
3.	INFORMATIONS LIEES A L'UTILISATION .	8
4.	INSTALLATION DU SYSTEME D'ATTACHE RAPIDE	13
	<i>Installation du système d'attache rapide à loquet</i>	<i>14</i>
	<i>Installation du système d'attache rapide à vis...</i>	<i>17</i>
5.	MAPPING	21
	<i>Mapping PC.....</i>	<i>21</i>
	<i>Mapping PS4™/PS5™</i>	<i>22</i>
	<i>Mapping Xbox Series/Xbox One</i>	<i>23</i>
6.	FONCTIONNEMENT DES LED	24
	<i>Entrer dans le menu LED/ quitter le menu LED.....</i>	<i>25</i>
	<i>Régler l'intensité des LED.....</i>	<i>27</i>
	<i>Changer le mode des LED : GT3 ou Formula..</i>	<i>28</i>

7.	PERSONNALISATION DES PALETTES.....	29
	<i>Ajuster l'écartement des palettes</i>	<i>31</i>
	<i>Ajuster la course des palettes</i>	<i>33</i>
	<i>Ajuster la sensibilité magnétique et le son des palettes</i>	<i>35</i>
8.	FAQ ET SUPPORT TECHNIQUE	37



FERRARI 488 GT3 WHEEL ADD-ON

Inscrivez-vous dans la légende de la compétition GT au volant de la Ferrari 488 GT3 Wheel Add-On, une roue pensée pour la performance et compatible avec les toutes les bases Thrustmaster.

Ce manuel va vous aider à installer et utiliser dans les meilleures conditions votre roue Ferrari 488 GT3 Wheel Add-On. Avant de vous lancer dans la course, lisez attentivement les instructions et les avertissements, ils vous aideront à tirer le maximum de plaisir de votre produit.



1. Contenu de la boîte

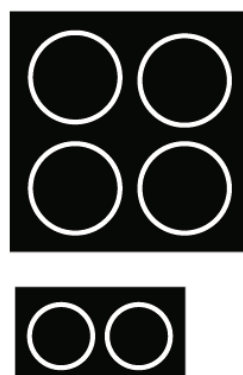
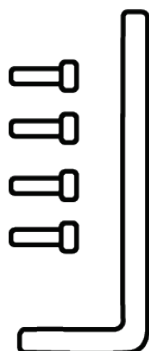
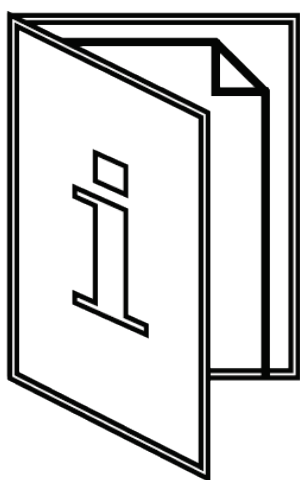
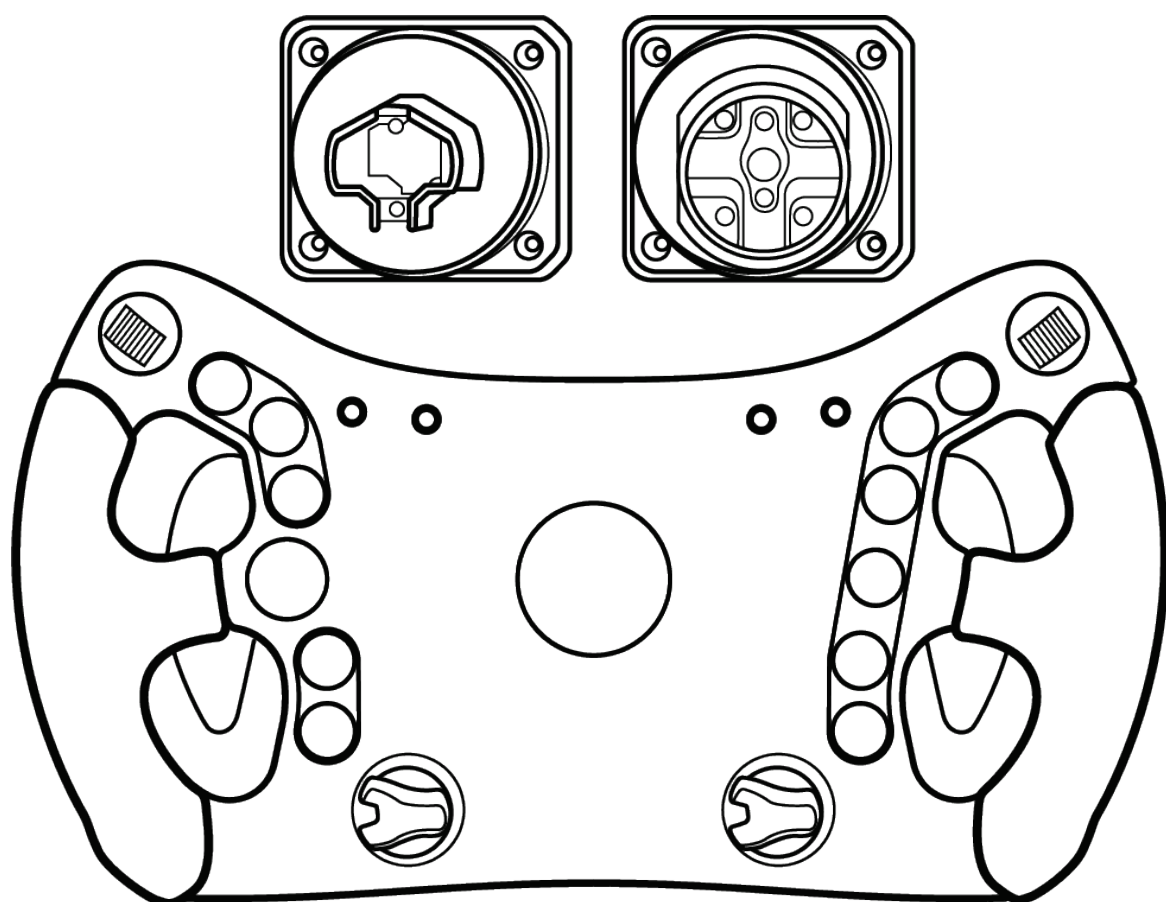



2. Caractéristiques

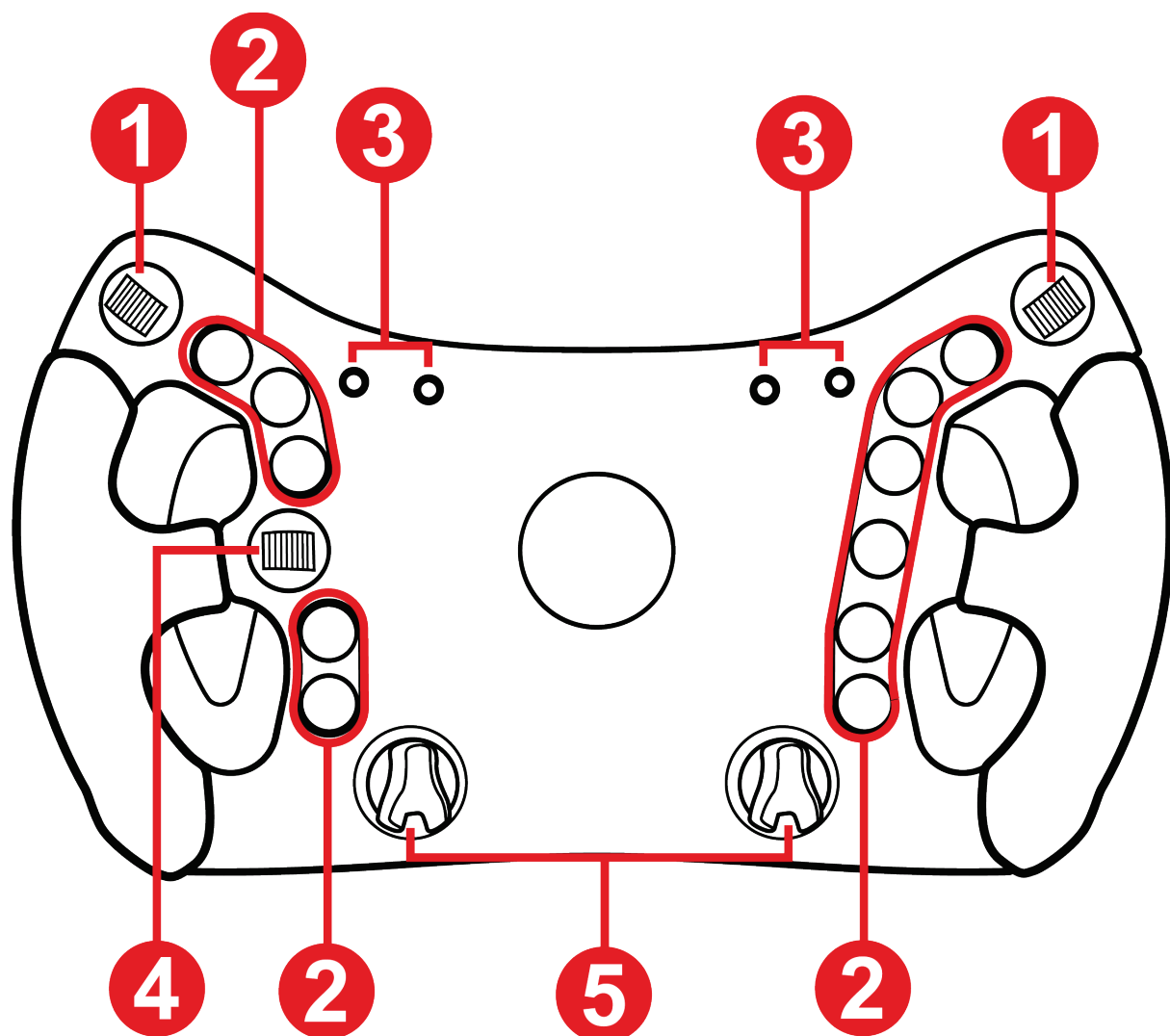

❶ Encodeurs de pouce

❷ 11 boutons d'action

❸ LED RPM et informations de course (drapeaux, stands)

❹ D-pad

❺ Encodeurs rotatifs

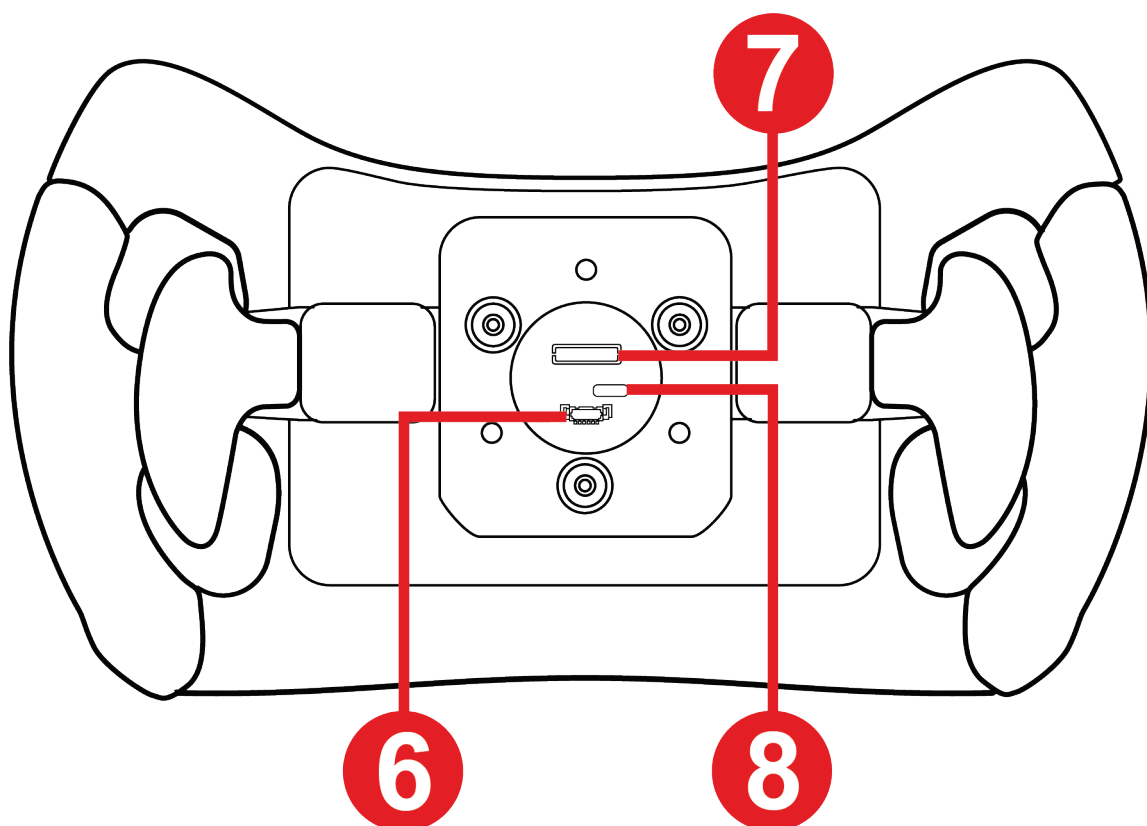

⑥ Port de branchement du support d'attache rapide à loquet

⑦ Port de branchement du support d'attache rapide à vis

⑧ Port USB-C (si mise à jour du firmware requise – câble non fourni)

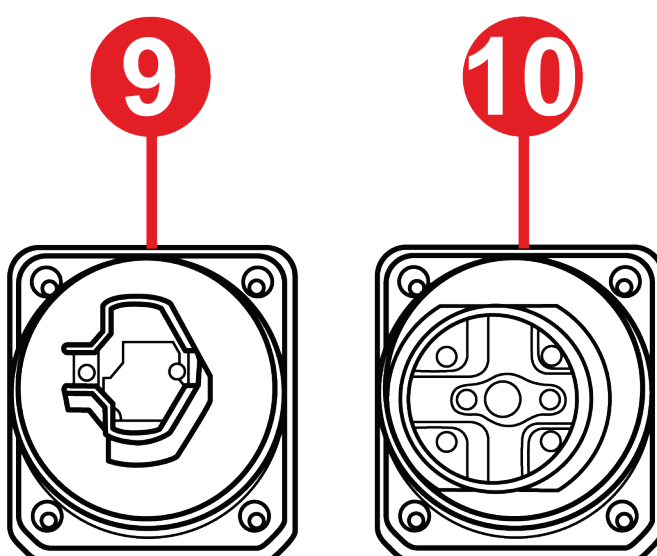

⑨ Support d'attache rapide à loquet

⑩ Support d'attache rapide à vis



3. Informations liées à l'utilisation



Documentation

Avant d'utiliser ce produit, relisez attentivement cette documentation et conservez-la pour pouvoir la consulter ultérieurement.



Choc électrique

- Conservez le produit dans un endroit sec et ne l'exposez ni à la poussière ni au soleil.
- Ne tordez pas et ne tirez pas sur les connecteurs et câbles.
- Respectez les sens de branchement.
- Ne renversez pas de liquide sur le produit et ses connecteurs.
- Ne mettez pas le produit en court-circuit.
- Ne démontez jamais le produit (hormis dans les cas de personnalisation spécifiés dans ce manuel), ne le jetez pas au feu et ne l'exposez pas à des températures élevées.
- N'ouvrez pas l'appareil. L'appareil ne contient pas de pièces réparables par l'utilisateur. Confiez toute réparation au fabricant, à une agence spécifiée ou un technicien qualifié.



Sécurisation de la zone de jeu

- Ne posez pas d'objet pouvant perturber la pratique de l'utilisateur, provoquer un mouvement inapproprié ou une interruption par une autre personne (tasse à café, téléphone, clés, par exemple).
- Ne couvrez pas les câbles d'alimentation par un tapis, couverture ou autre et ne placez pas de câble dans un lieu de passage.



Blessures dues au retour de force et aux mouvements répétitifs

Utiliser un volant à retour de force peut causer des douleurs aux muscles et aux articulations. Afin d'éviter tout problème :

- Échauffez-vous et évitez les périodes trop longues de pratique.
- Faites une pause de 10 à 15 minutes après chaque heure de pratique.
- Si vous éprouvez fatigue ou douleur au niveau des mains, des poignets, des bras, des pieds ou des jambes, appuyez sur le bouton d'arrêt du retour de force, éteignez la base et reposez-vous pendant quelques heures avant de recommencer à pratiquer.
- Si les symptômes ou les douleurs indiqués ci-dessus persistent lorsque vous reprenez la pratique, arrêtez de pratiquer et consultez votre médecin.
- Ne réglez pas le retour de force à un niveau trop élevé par rapport à votre expertise et votre condition physique.
- Laissez hors de portée des personnes de moins de 16 ans.
- Vérifiez que la base et le volant sont correctement fixés, conformément aux instructions du manuel.



Risque de rotations imprévues, puissantes et rapides : n'introduisez jamais une main ou un bras à l'intérieur de la roue du volant ou sur la trajectoire de rotation du volant.

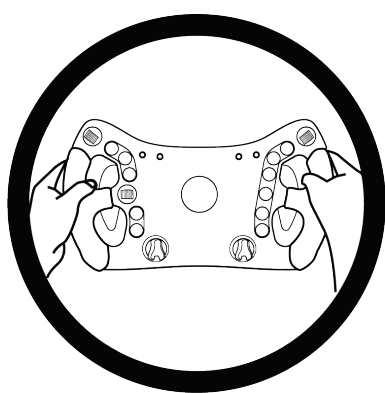

Lors des phases d'utilisation, laissez toujours vos deux mains correctement positionnées sur le volant sans jamais le lâcher complètement.



Produit à manipuler uniquement par des personnes âgées de **16 ans ou plus**.



4. Installation du système d'attache rapide

La roue **Ferrari 488 GT3 Wheel Add-On** est fournie avec deux systèmes d'attache rapide correspondant aux formats des bases Thrustmaster.

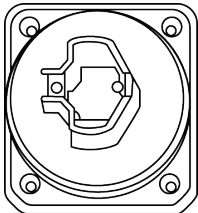
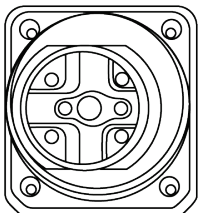
Systeme	Bases compatibles
 Attache rapide à loquet	T818 et futures bases Thrustmaster.
 Attache rapide à vis	T-GT / T-GT II Servo Base, T300 RS Servo Base, TS PC Racer, TS-XW, TX Racing Wheel Servo Base, TS-XW Servo Base.



Avant chaque utilisation, vérifiez que la roue **Ferrari 488 GT3 Wheel Add-On** est toujours correctement fixée à la base, conformément aux instructions du manuel de la base.



Installation du système d'attache rapide à loquet

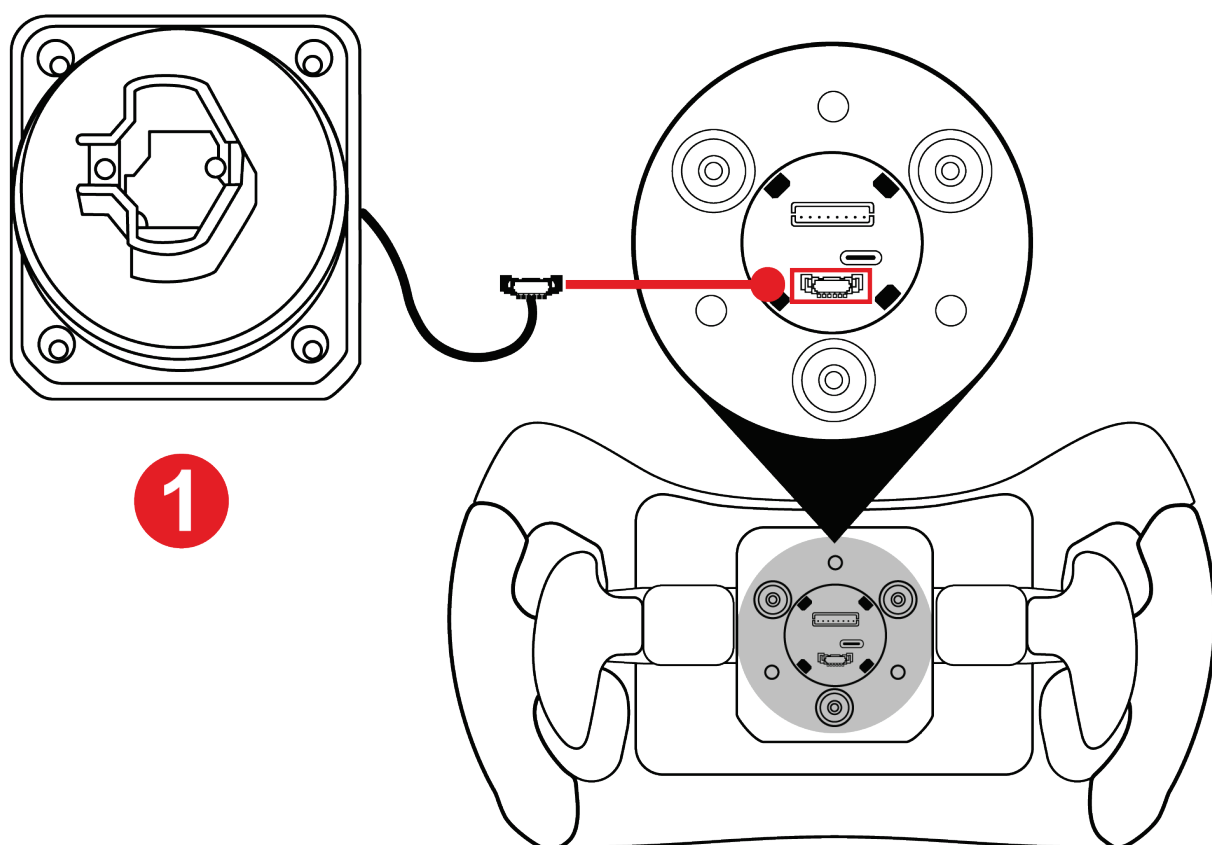

1 Branchez le connecteur du système d'attache rapide sur le port correspondant situé au dos de la roue.



Pour éviter de pincer le câble, rentrez celui-ci dans son logement avant de procéder au serrage.

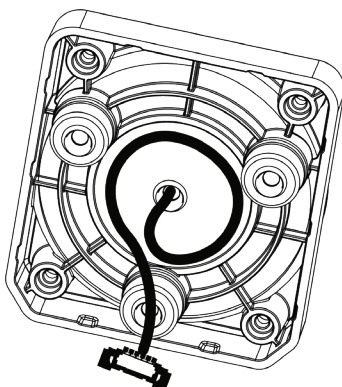

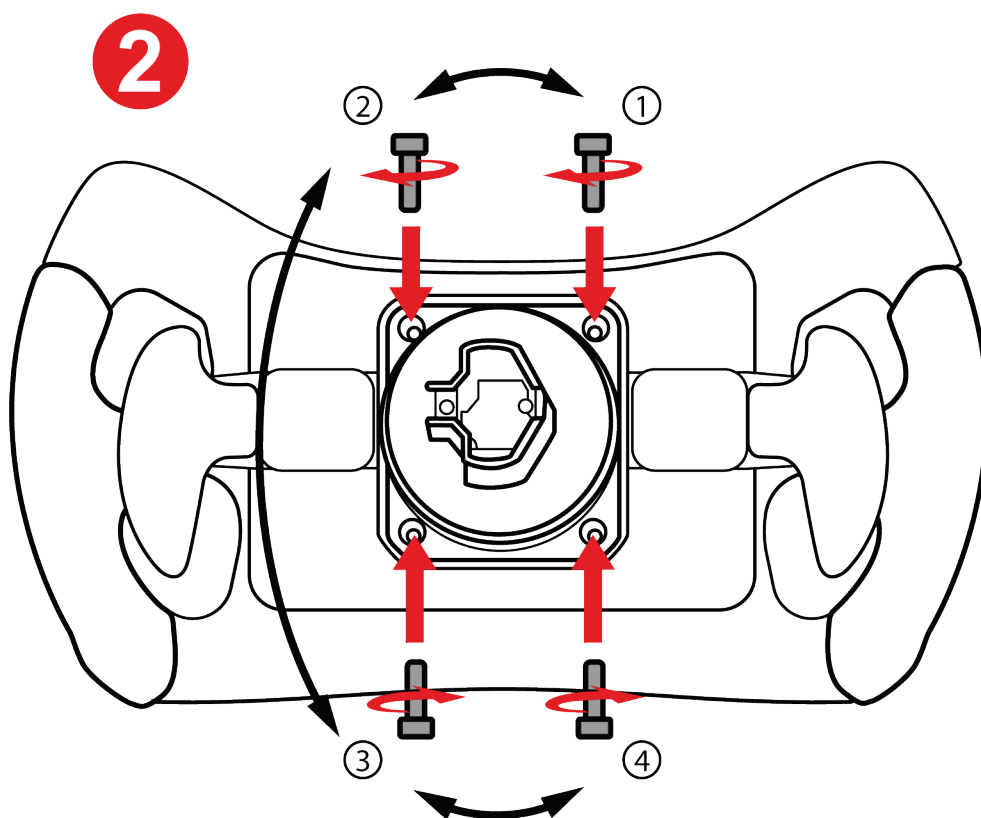

2 Insérez le système d'attache rapide et vissez-le à l'aide de la clé Torx fournie.



Lors du montage du support, ne serrez pas trop fort les vis.

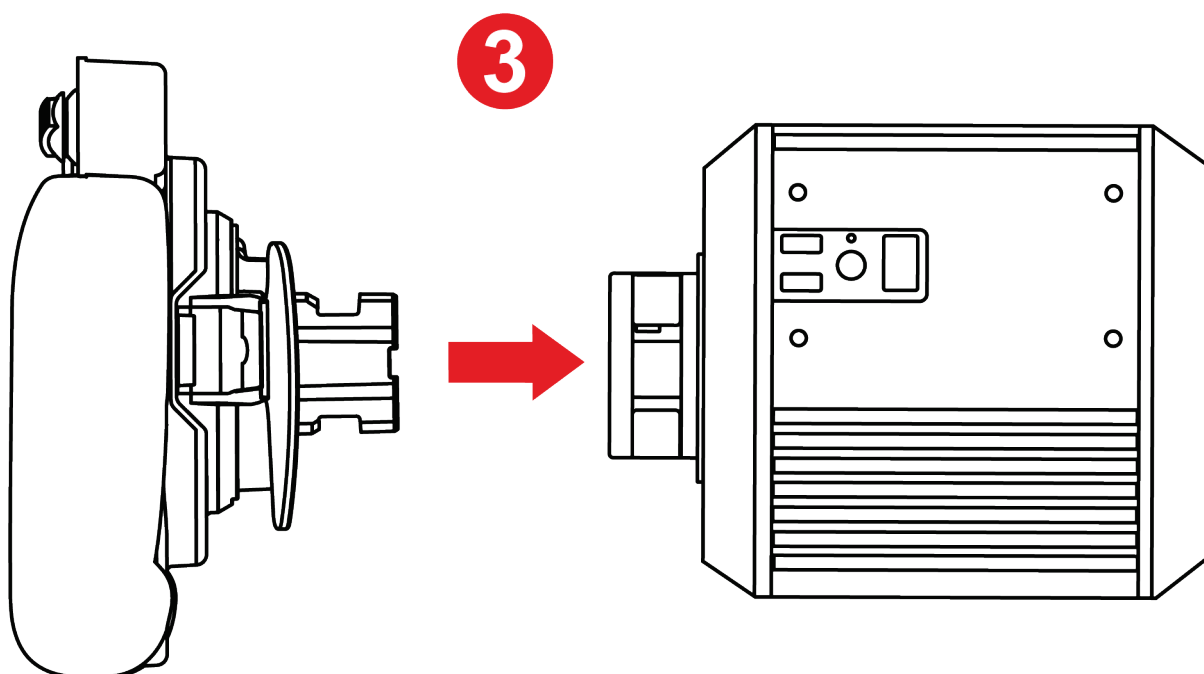

3 Montez la roue sur la base.



Respectez la procédure de montage spécifiée dans le manuel de la base.



Installation du système d'attache rapide à vis

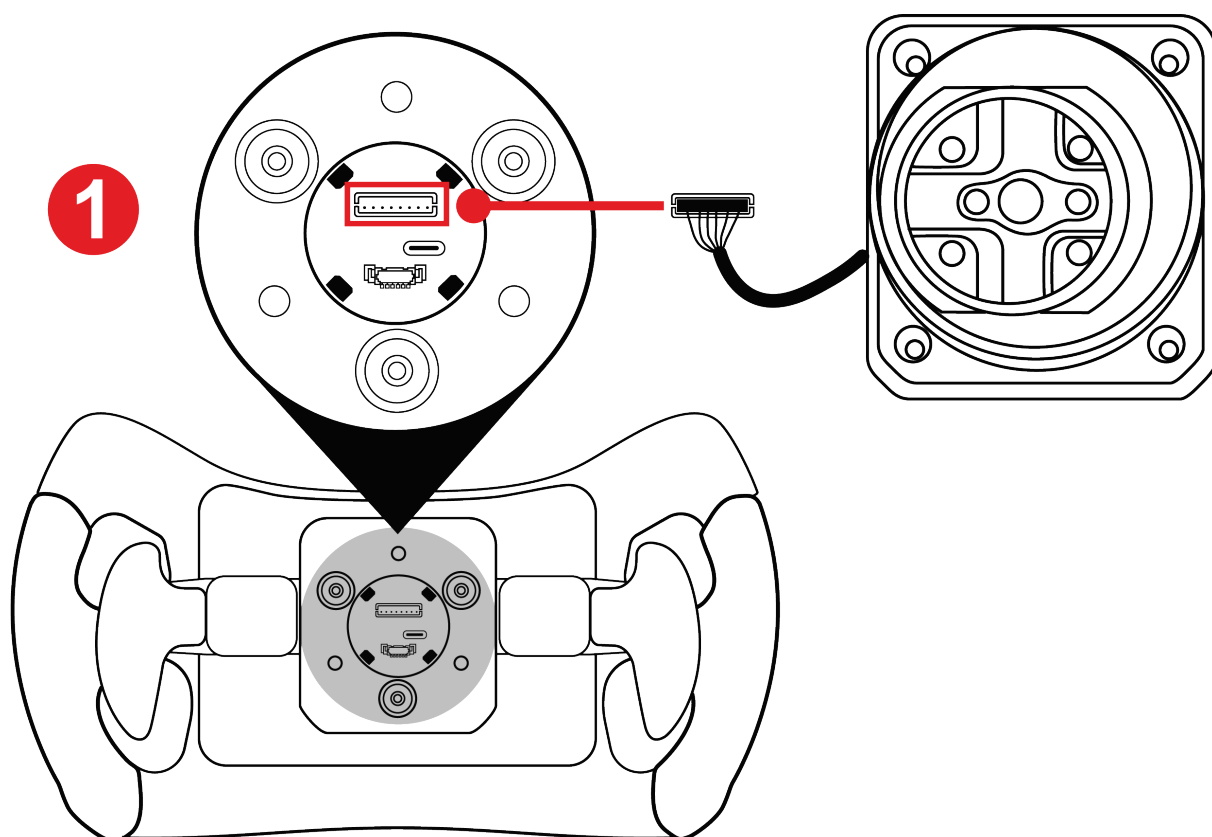

1 Branchez le connecteur du système d'attache rapide sur le port correspondant situé au dos de la roue.



Pour éviter de pincer le câble, rentrez celui-ci dans son logement avant de procéder au serrage.

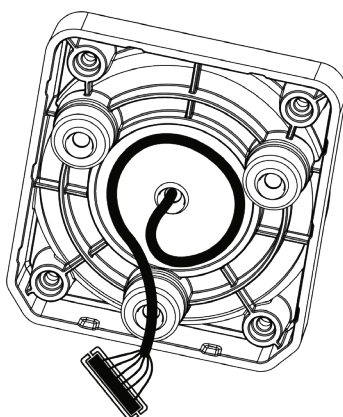

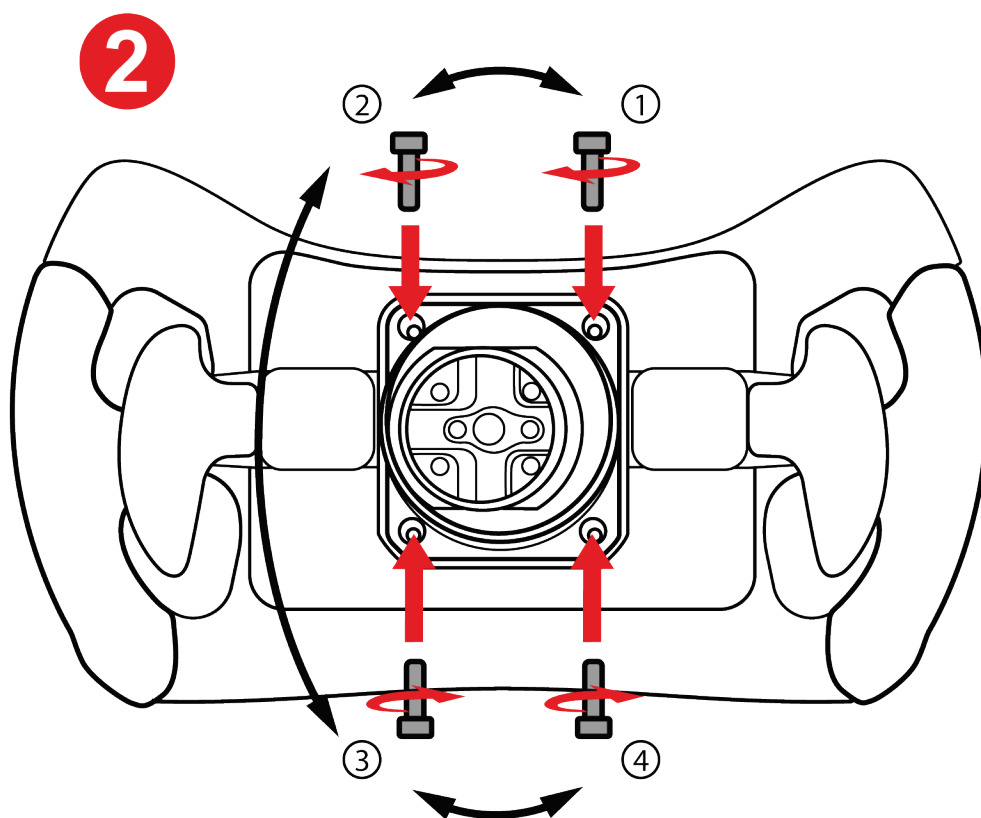

2 Insérez le système d'attache rapide et vissez-le à l'aide de la clé Torx fournie.



Lors du montage du support, ne serrez pas trop fort les vis.

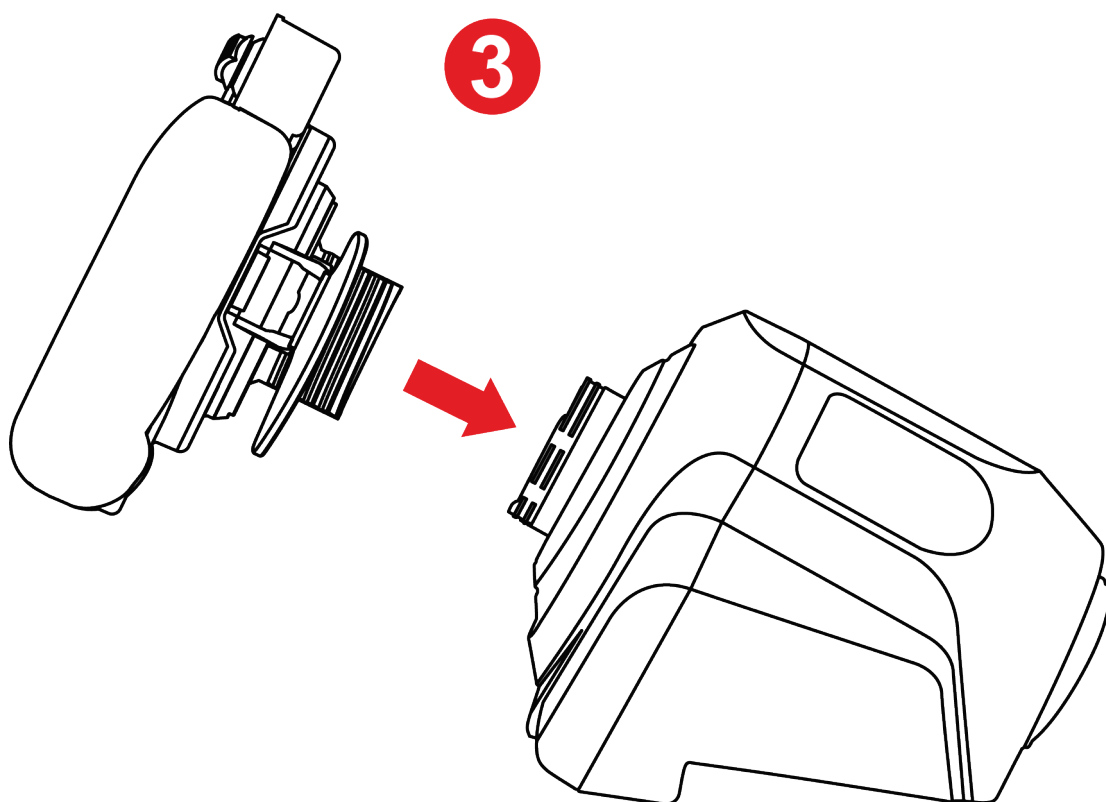

3 Montez la roue sur la base.



Respectez la procédure de montage spécifiée dans le manuel de la base.



Ne branchez jamais le Quick Release Adapter (fourni avec la base T818 et vendu séparément) sur le système d'attache rapide à vis, en vue de l'utiliser sur une base T818.

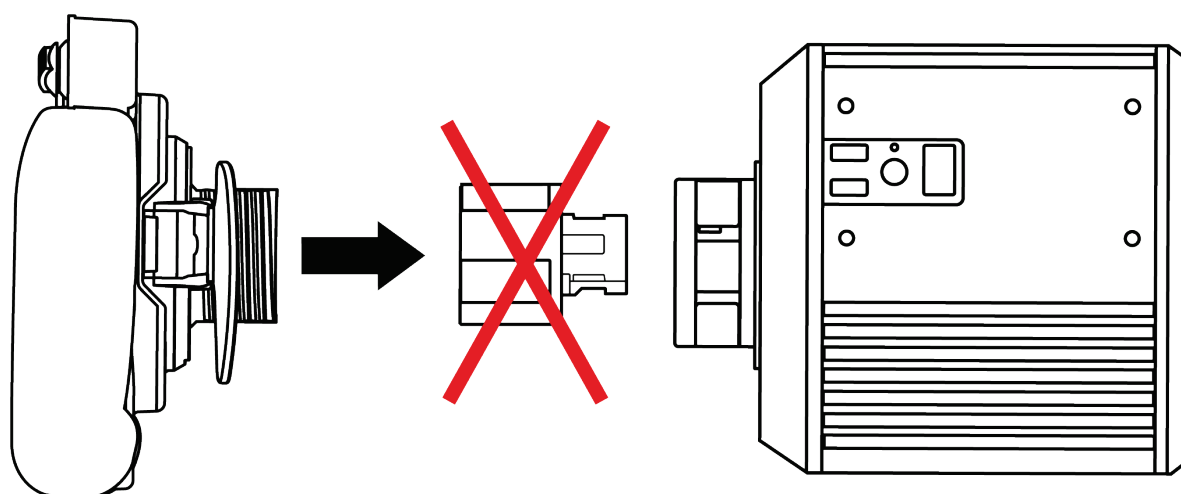
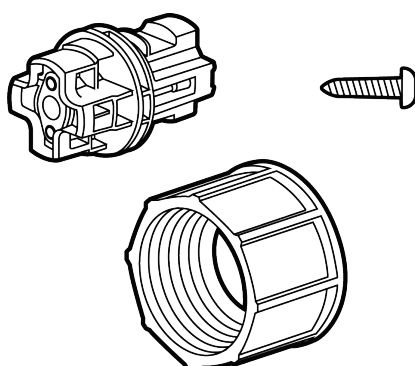

Pour une utilisation sur une base T818 ou une base équipée d'un système de branchement à loquet, utilisez uniquement le **système d'attache rapide à loquet** fourni avec la roue **Ferrari 488 GT3 Wheel Add-On**.



5. Mapping

Mapping PC

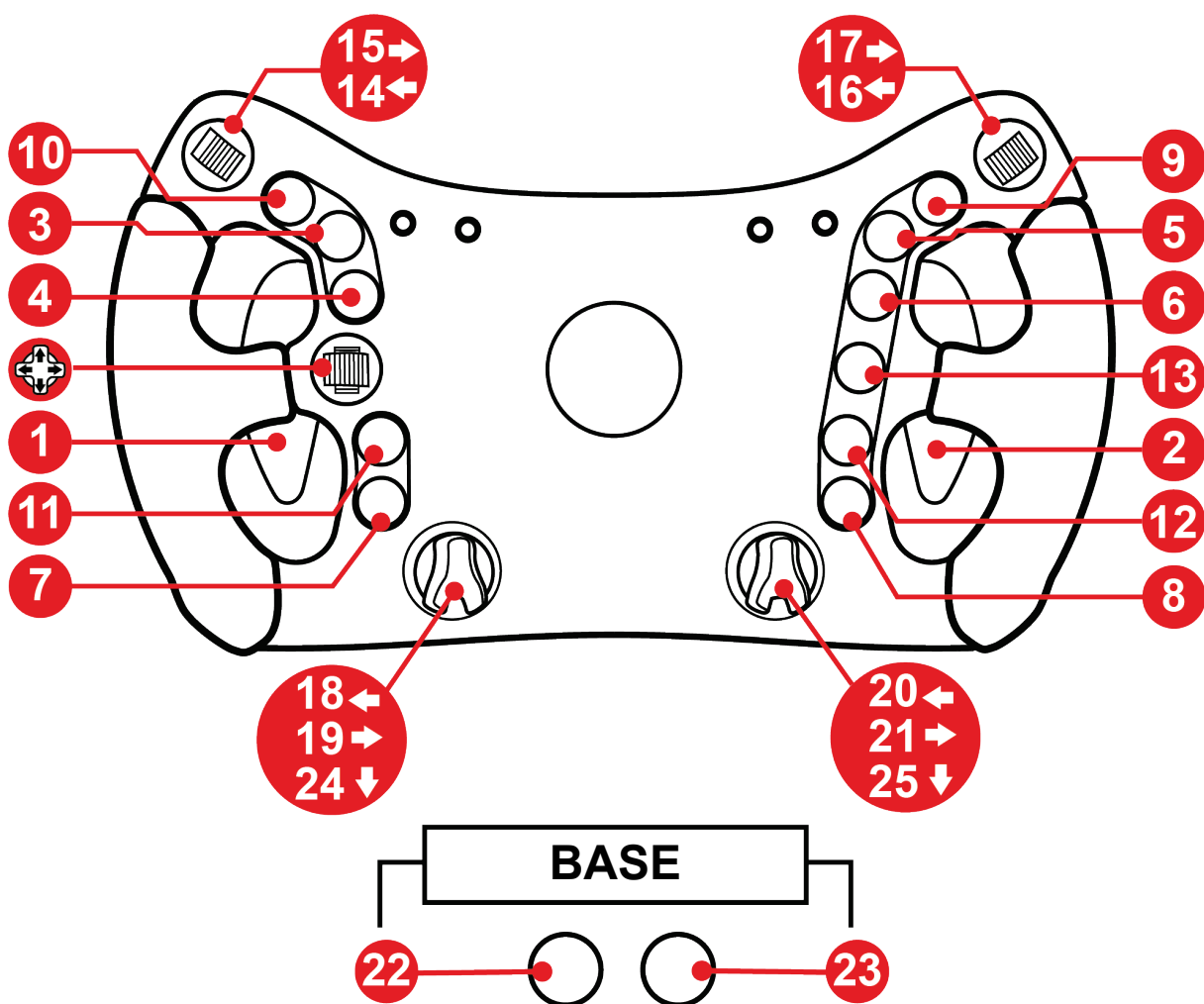



Mapping PS4™/PS5™

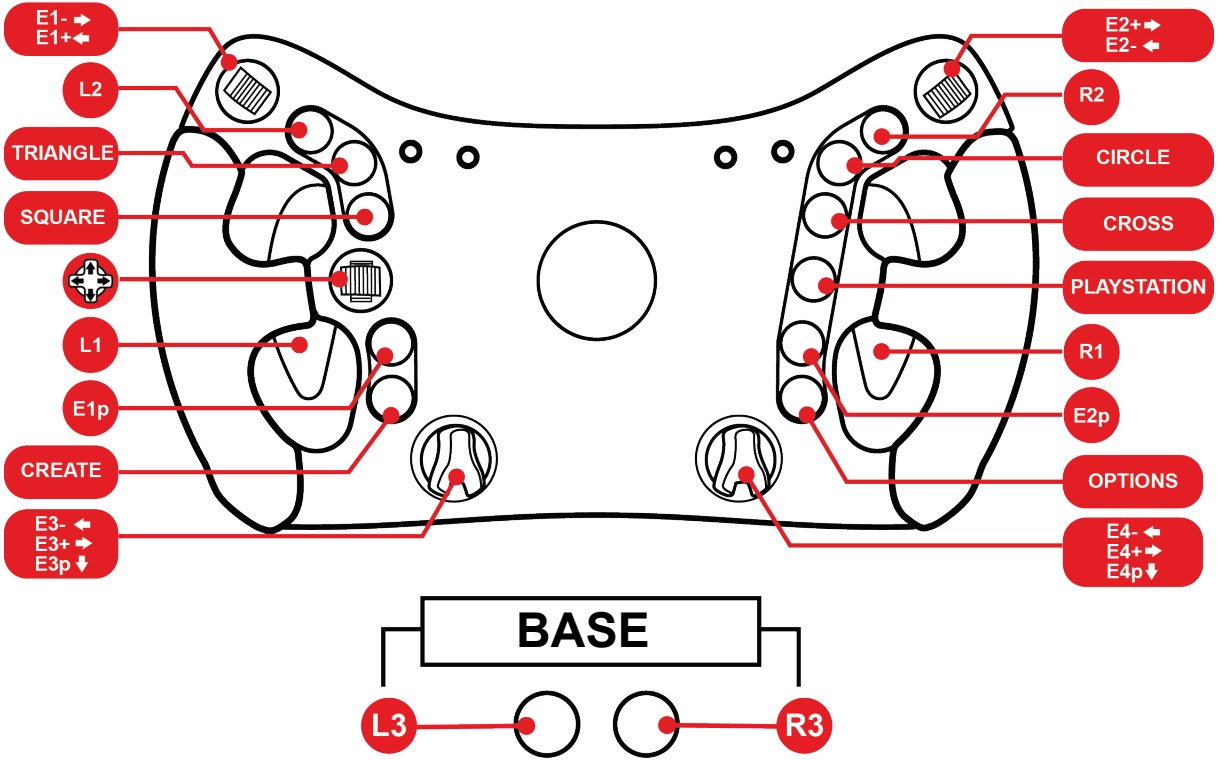



Mapping Xbox Series/Xbox One

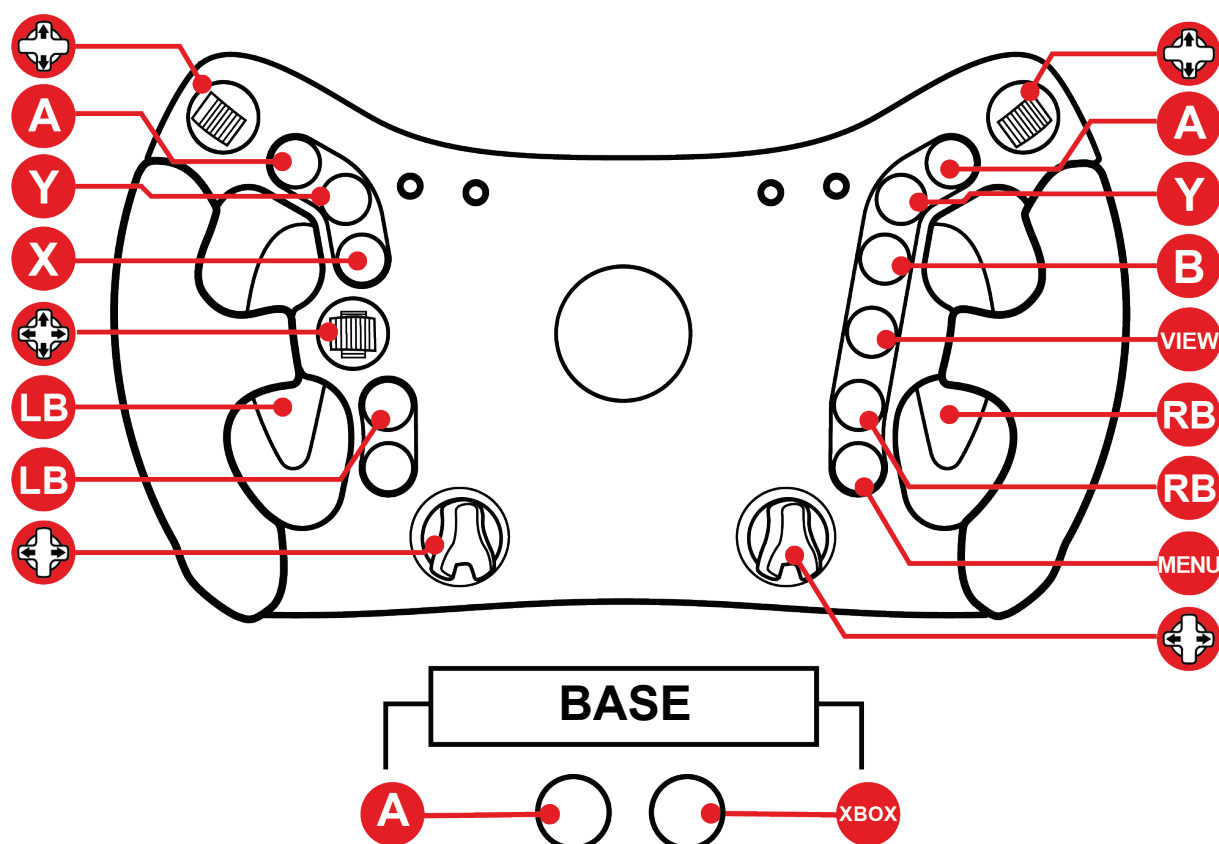

Sur Xbox Series et Xbox One :

- Les LED de la roue Ferrari 488 GT3 ne sont pas fonctionnelles en raison des restrictions du protocole de la console.
- Certaines fonctionnalités (encodeurs, nombre de boutons) sont limitées par le protocole de la console.



6. Fonctionnement des LED

La roue **Ferrari 488 GT3 Wheel Add-On** offre des informations consultables via les LED : drapeau (flag), stand (pit) et RPM.

L'affichage de ces informations peut être personnalisé : intensité, couleur des LED RPM en fonction du mode (GT3 ou Formula).

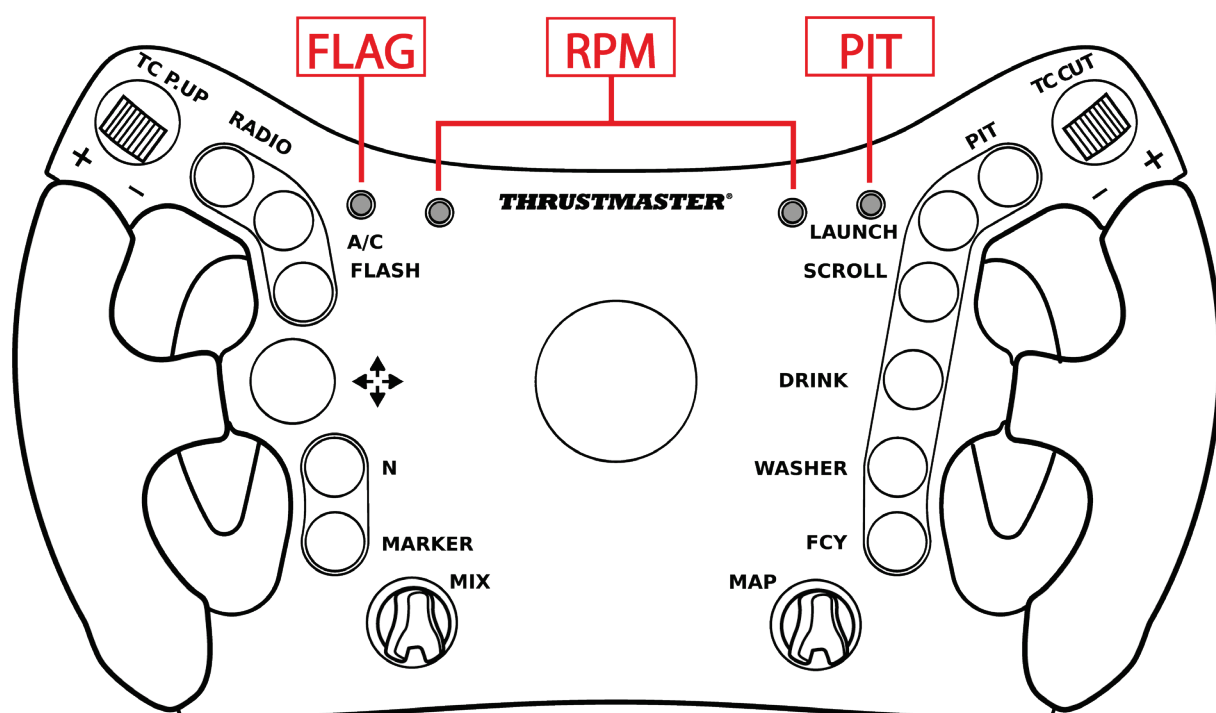

Les LED sont fonctionnelles sur PC et PS4™/PS5™.

Sur Xbox Series et Xbox One, les LED ne sont pas fonctionnelles en raison des restrictions du protocole de la console.



Entrer dans le menu LED/quitter le menu LED

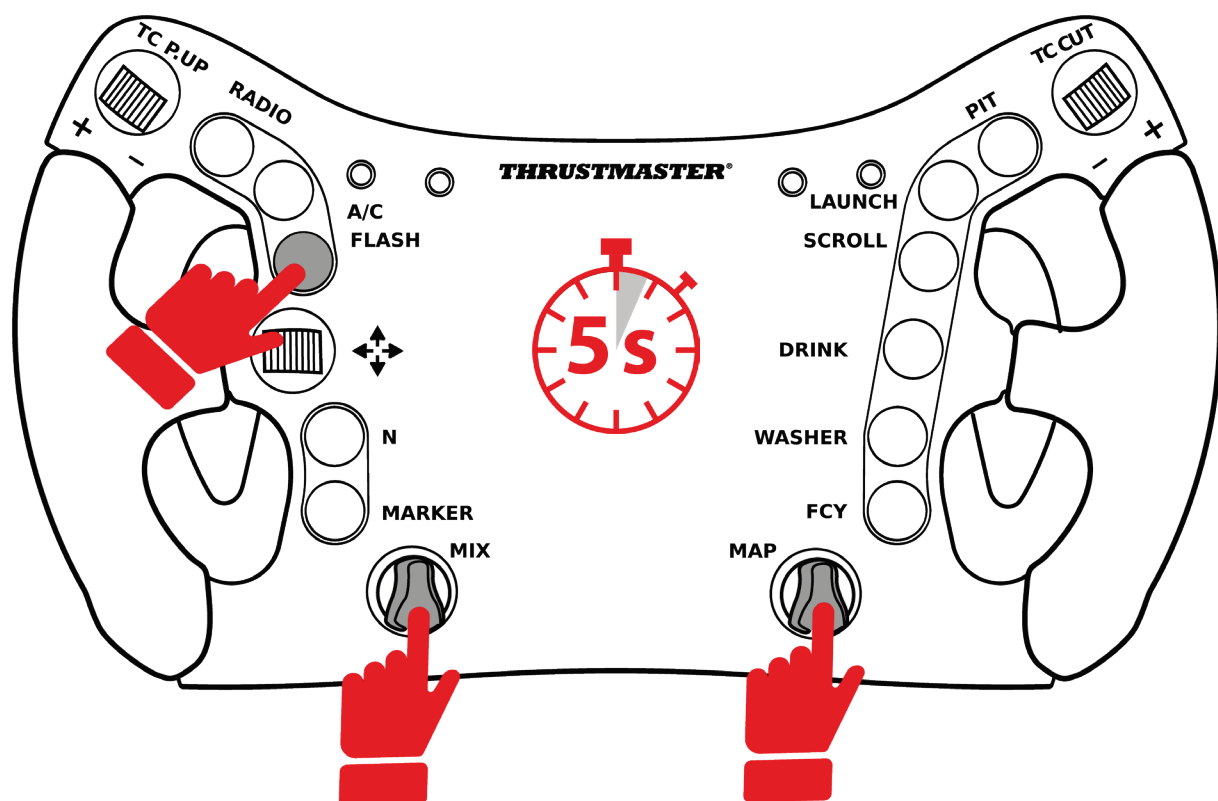

- Pour entrer dans le menu LED, appuyez simultanément sur le bouton **FLASH** et les deux **encodeurs rotatifs** pendant **5 secondes**, puis relâchez-les.

- Pour quitter le menu LED, appuyez simultanément sur le bouton **FLASH** et les deux **encodeurs rotatifs**, puis relâchez-les.



FLAG

RPM

PIT



Entrée dans le menu LED : les LED FLAG, PIT et l'une des LED RPM (rouge à gauche, ou bleue à droite) s'allument.



Sortie du menu LED : les quatre LED s'éteignent.



Régler l'intensité des LED

- Entrez dans le menu LED en appuyant simultanément sur le bouton **FLASH** et les deux **encodeurs rotatifs pendant 5 secondes**, puis relâchez-les.
- Tournez l'**encodeur gauche (MIX)** vers la gauche pour diminuer l'intensité, ou vers la droite pour augmenter l'intensité.



- Quittez le menu LED en appuyant simultanément sur le bouton **FLASH** et les deux **encodeurs rotatifs**, puis relâchez-les.



Changer le mode des LED : GT3 ou Formula

- Entrez dans le menu LED en appuyant simultanément sur le bouton **FLASH** et les deux **encodeurs rotatifs** pendant 5 secondes, puis relâchez-les.
- Tournez l'**encodeur droit (MAP)** vers la gauche pour sélectionner le mode GT3 (LED rouge), ou vers la droite pour sélectionner le mode Formula (LED bleue).



Mode GT3 (mode par défaut)



Mode FORMULA

- Quittez le menu LED en appuyant simultanément sur le bouton **FLASH** et les deux **encodeurs rotatifs**, puis relâchez-les.



7. Personnalisation des palettes

Les palettes de la roue **Ferrari 488 GT3 Wheel Add-On** sont ajustables en **écartement** et en **course**.

L'**écartement** consiste à ajuster en largeur la palette, ce qui modifie la distance entre la poignée et la palette de vitesse.

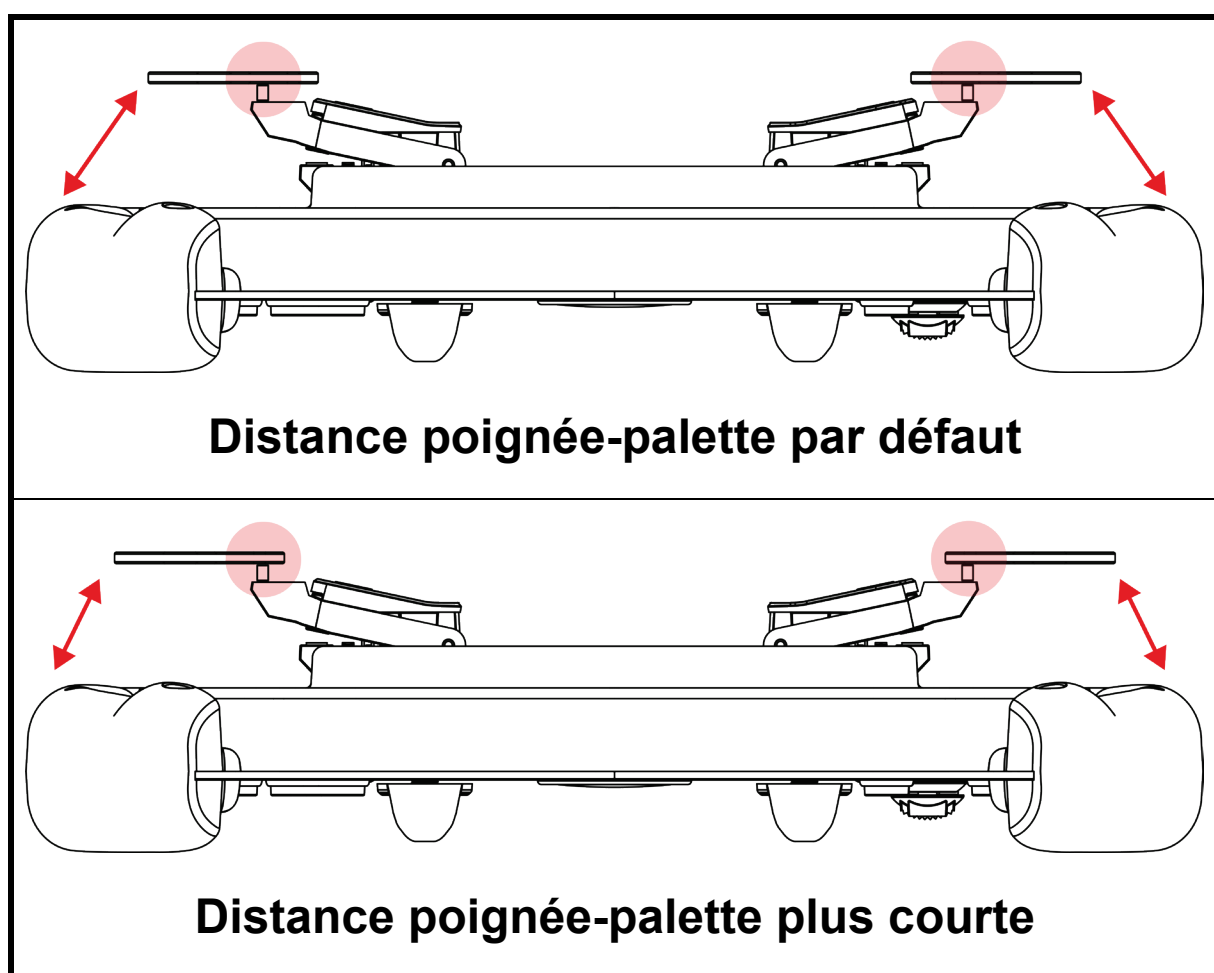



L'ajustement de la **course** grâce aux entretoises modifie la distance d'activation de la palette.

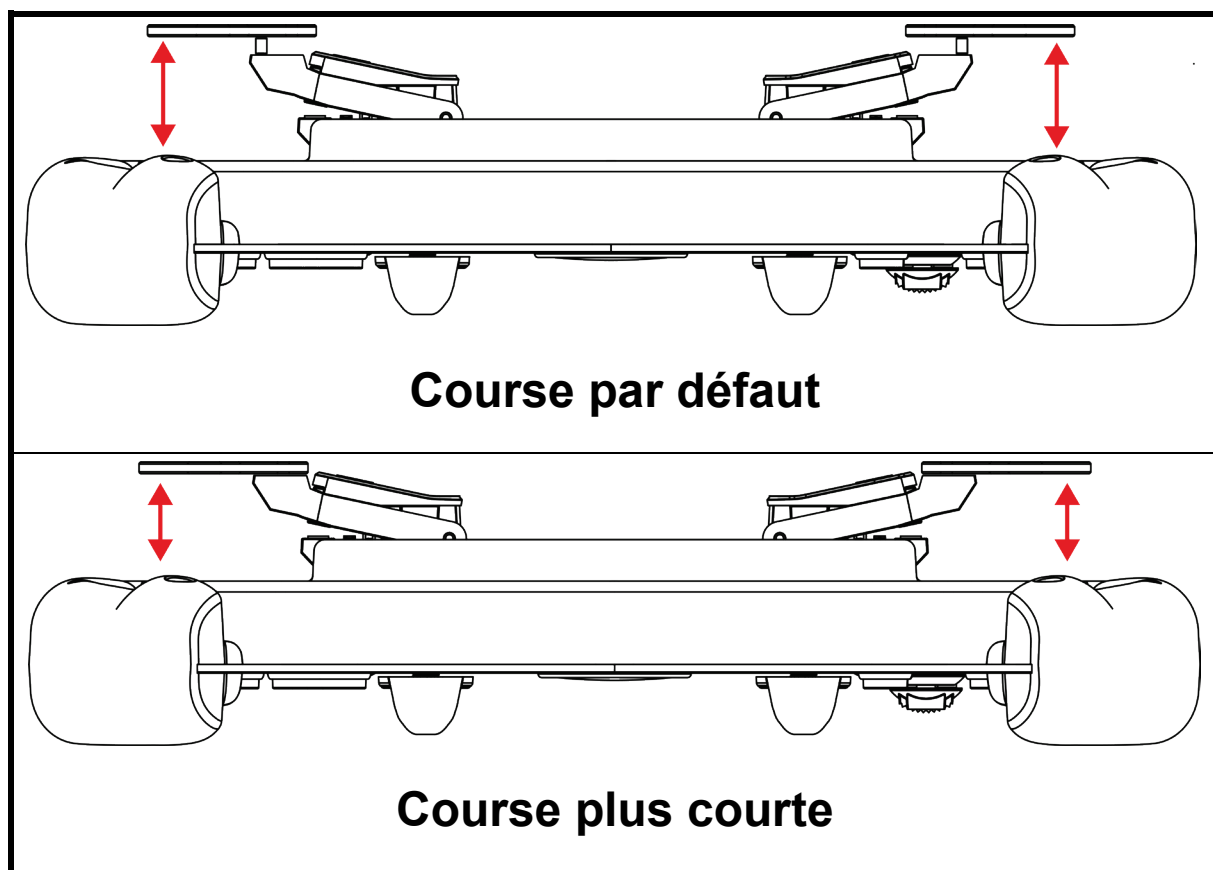

Il est également possible d'ajuster la **sensibilité magnétique** et le **niveau sonore** produit par les palettes en utilisant les kits de patins fournis.

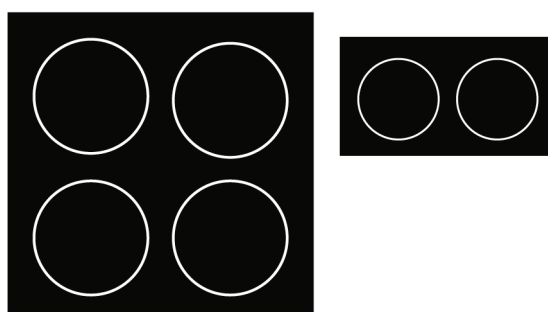



Ajuster l'écartement des palettes

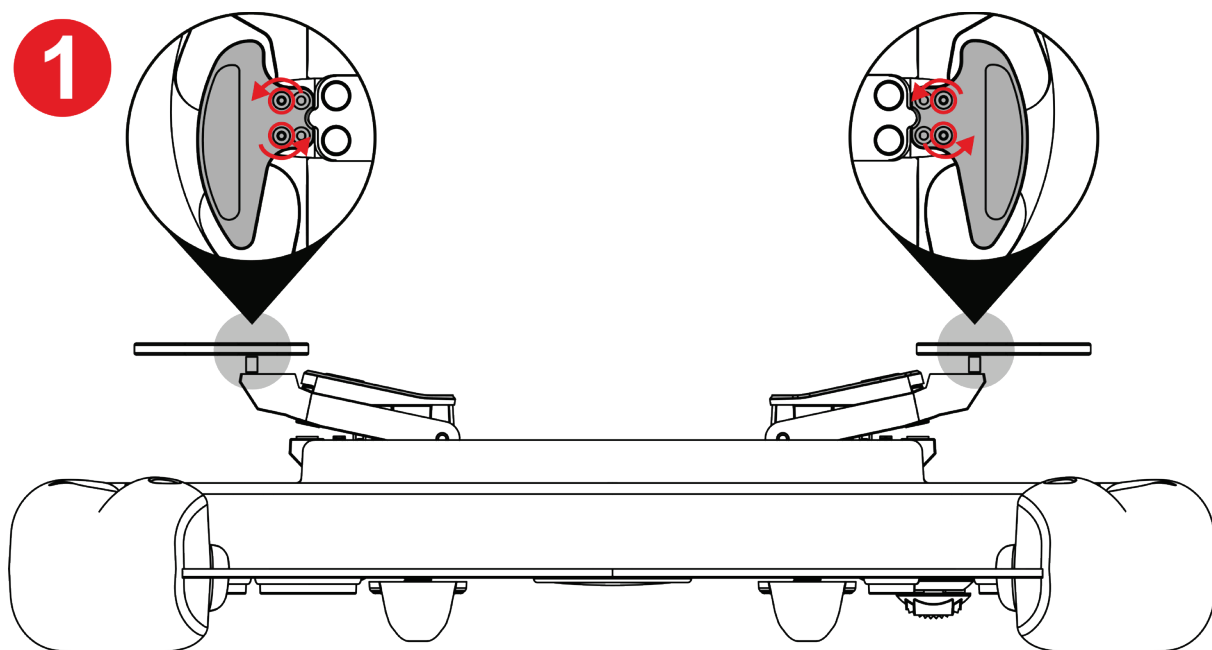

1 Dévissez les quatre vis des palettes à l'aide de la clé Torx fournie.

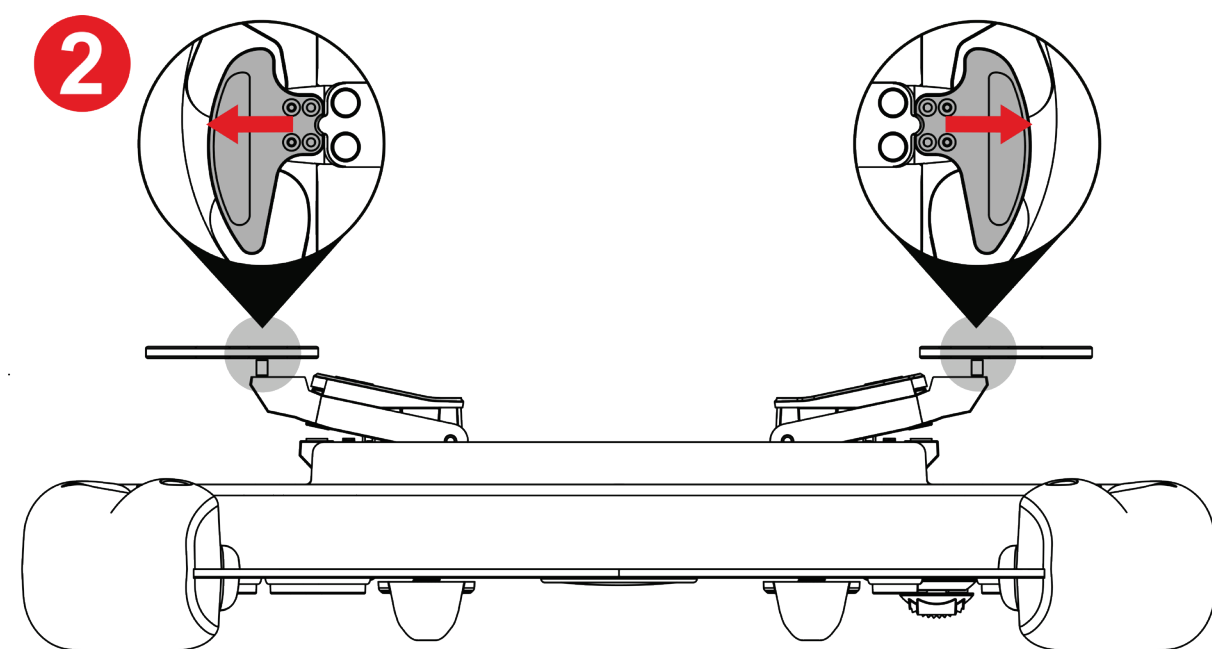

2 Décalez les palettes vers l'extérieur pour faire correspondre les trous.

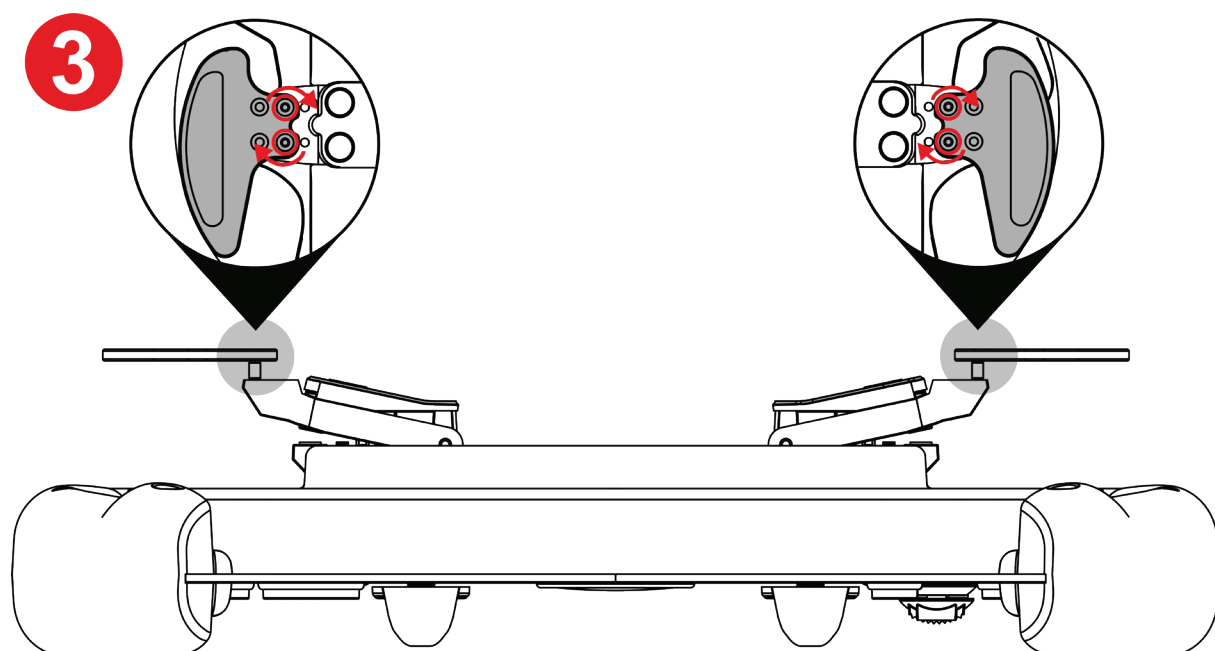

3 Revissez les quatre vis des palettes à l'aide de la clé Torx fournie.



Ajuster la course des palettes

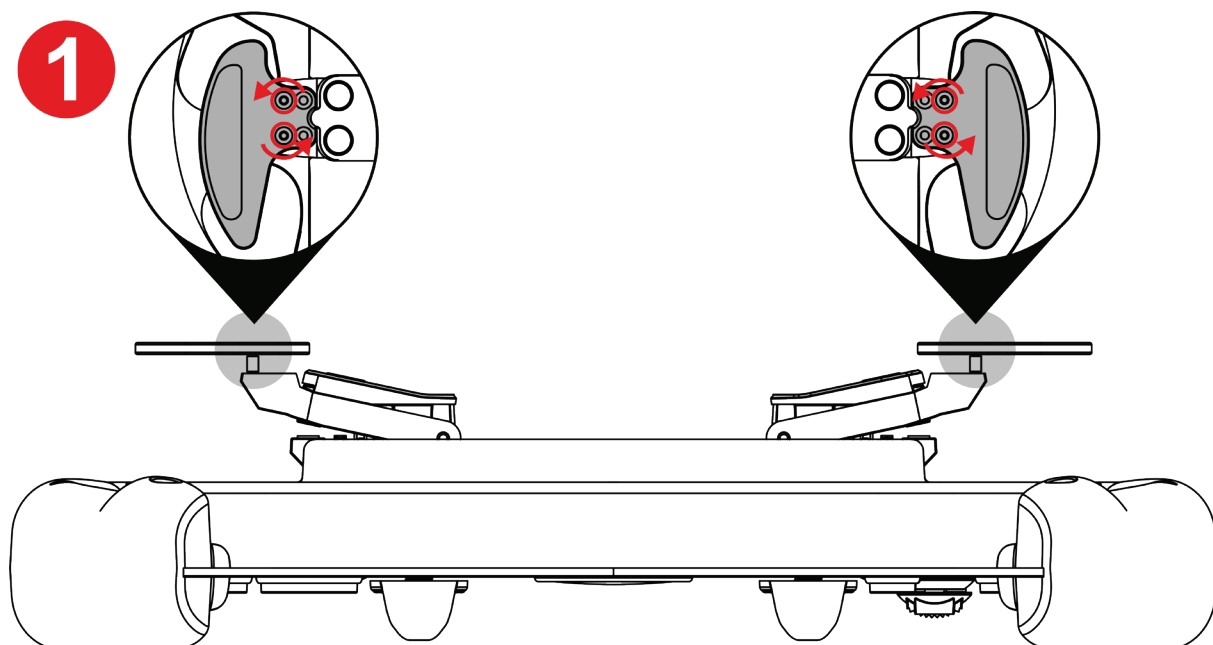

1 Dévissez les quatre vis des palettes à l'aide de la clé Torx fournie.

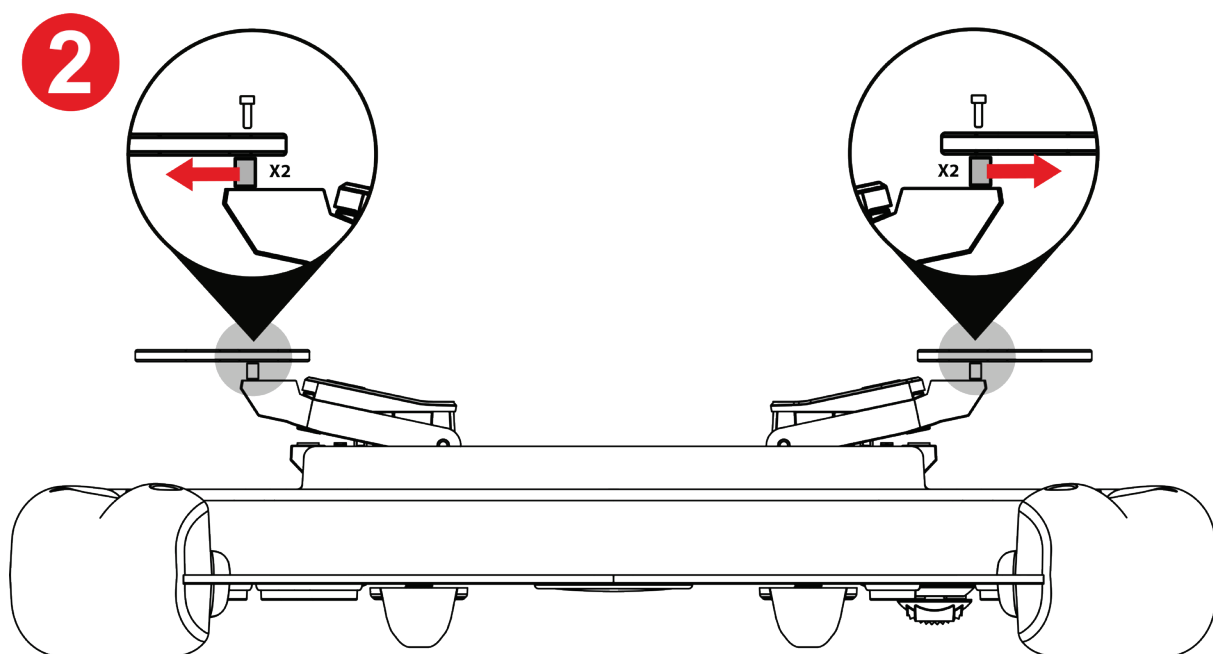

2 Retirez les entretoises.

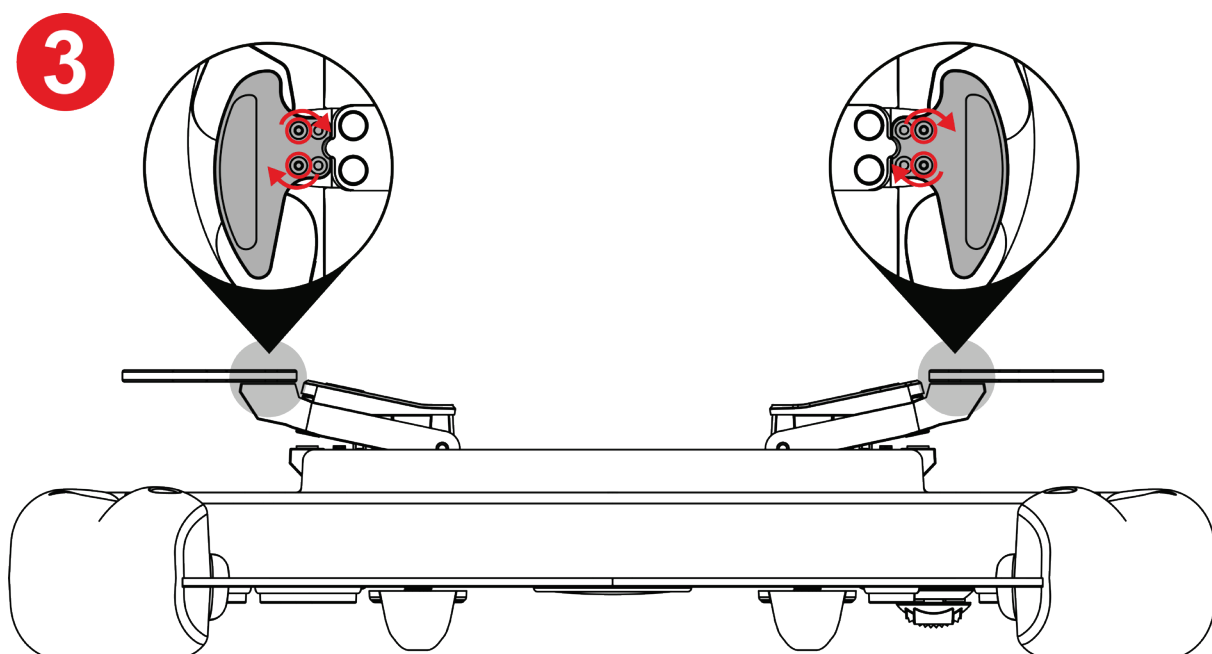

3 Revissez les quatre vis des palettes à l'aide de la clé Torx fournie.



Ajuster la sensibilité magnétique et le son des palettes

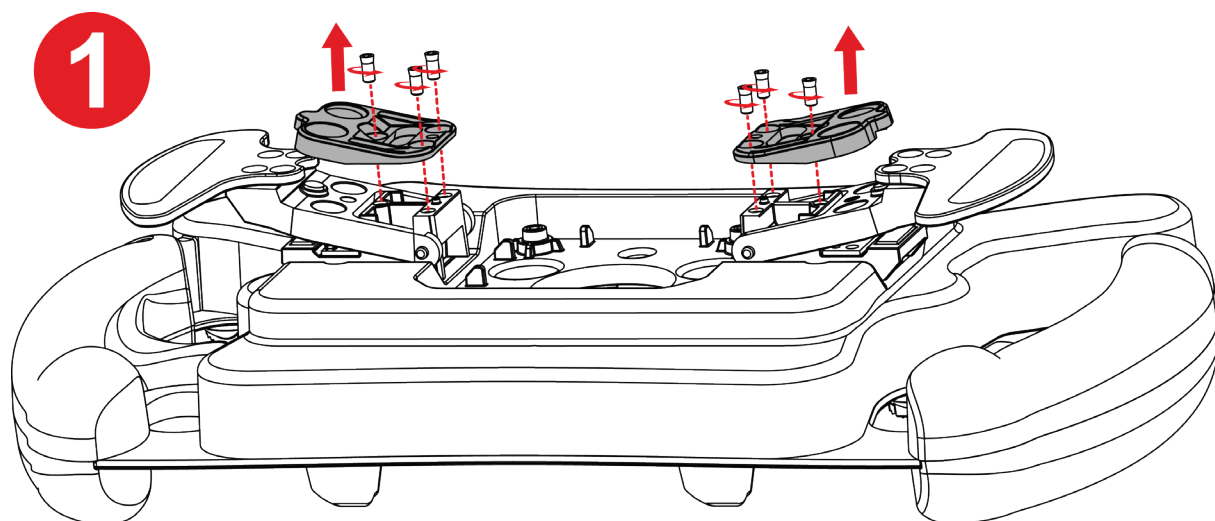

❶ Retirez les butées magnétiques en dévissant les six vis des butées à l'aide de la clé Torx fournie.

❷

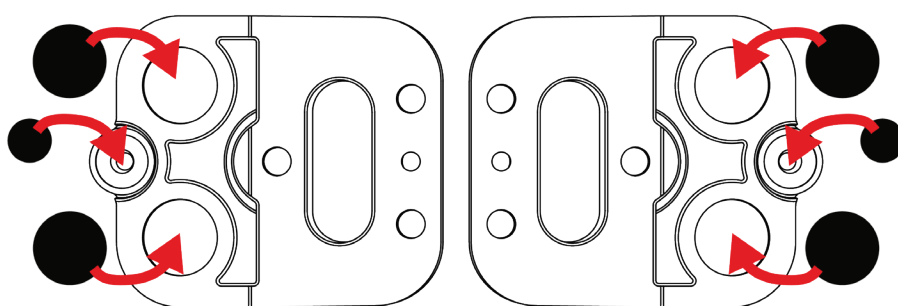
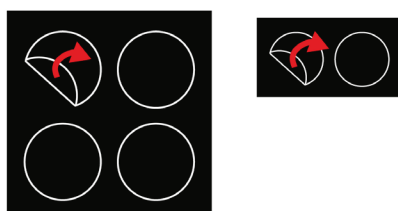

❷ Décollez les patins fournis et apposez-les aux emplacements prévus à cet effet, sous les butées magnétiques.



Reportez-vous au **Tableau de sensibilité magnétique et d'atténuation du son des palettes** pour connaître les configurations possibles et leurs effets.



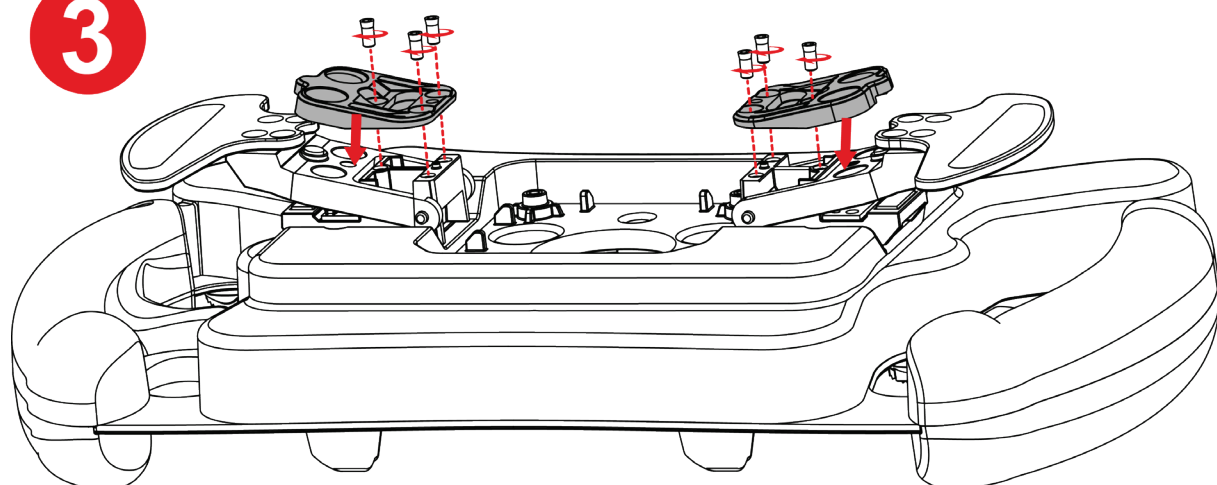

3

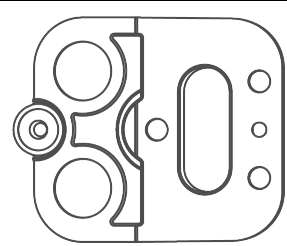
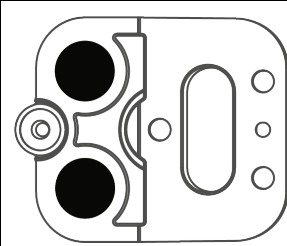
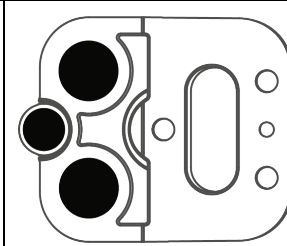

3 Remettez en place les butées magnétiques et revissez les six vis des butées à l'aide de la clé Torx fournie.

Tableau de sensibilité magnétique et d'atténuation du son des palettes

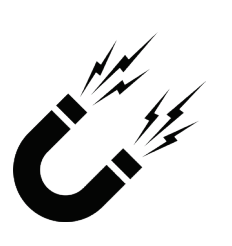
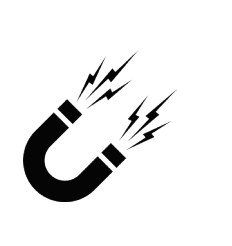
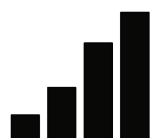
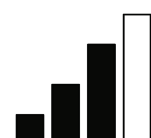
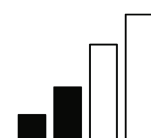
	 (par défaut)		
Sensibilité magnétique			
Son			



8. FAQ et support technique

Vous avez des questions ou vous rencontrez des problèmes techniques concernant la roue Ferrari 488 GT3 Wheel Add-On ? Consultez le site du support technique Thrustmaster :

<https://support.thrustmaster.com/product/ferrarif488gt3addon>.

Sur cette page, vous pourrez également mettre à jour le firmware de la roue.



THRUSTMASTER®

FERRARI 488 GT3 WHEEL ADD-ON

PC (Windows 10/11)

PS4™ / PS5™

Xbox Series / Xbox One

Benutzerhandbuch



Lesen Sie die Anweisungen in diesem Benutzerhandbuch **sorgfältig durch**, **bevor** Sie das Produkt installieren, **bevor** Sie es benutzen und **bevor** Sie es warten. Beachten Sie unbedingt die Sicherheitsanweisungen. Die Nichtbeachtung dieser Anweisungen kann zu Unfällen und/oder Schäden führen. Bewahren Sie dieses Benutzerhandbuch auf, damit Sie auch in Zukunft darin nachschlagen können.

VERPACKUNGSGEHALT

1.	VERPACKUNGSGEHALT	5
2.	FUNKTIONEN	6
3.	INFORMATIONEN ZUR VERWENDUNG DES LENKRADS	8
4.	MONTAGE DER QUICK RELEASE- HALTERUNG	13
	<i>Montage der Quick Release-Halterung für Verriegelungsbasis</i>	<i>14</i>
	<i>Montage der Quick Release-Halterung für Schraubbasis</i>	<i>17</i>
5.	MAPPING	21
	<i>Mapping für PC</i>	<i>21</i>
	<i>Mapping für PS4™/PS5™</i>	<i>22</i>
	<i>Mapping für Xbox Series/Xbox One</i>	<i>23</i>
6.	FUNKTIONSGEWISE DER LEDS	24
	<i>Aufrufen/Verlassen des LED-Menüs</i>	<i>25</i>
	<i>Einstellung der LED-Intensität</i>	<i>27</i>

Änderung des LED-Modus: GT3 oder

Formula28

7. INDIVIDUELLE ANPASSUNG DER

SCHALTWIPPEN29

8. FAQ UND TECHNISCHER SUPPORT37



FERRARI 488 GT3 WHEEL ADD-ON

Werden Sie Teil der Legende des GT-Rennsports mit dem Ferrari 488 GT3 Wheel Add-On, einem Lenkrad, das auf Performance ausgelegt und mit allen Thrustmaster-Lenkradbasen kompatibel ist.

Dieses Handbuch wird Ihnen helfen, Ihr Ferrari 488 GT3 Wheel Add-On unter optimalen Umständen zu installieren und zu verwenden. Bevor Sie mit dem Rennen beginnen, lesen Sie die Anweisungen und Warnhinweise sorgfältig durch: Sie werden Ihnen helfen, Ihr Produkt optimal zu nutzen.



1. Verpackungsinhalt

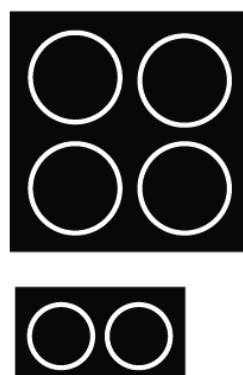
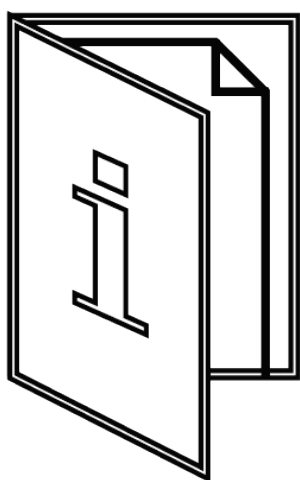
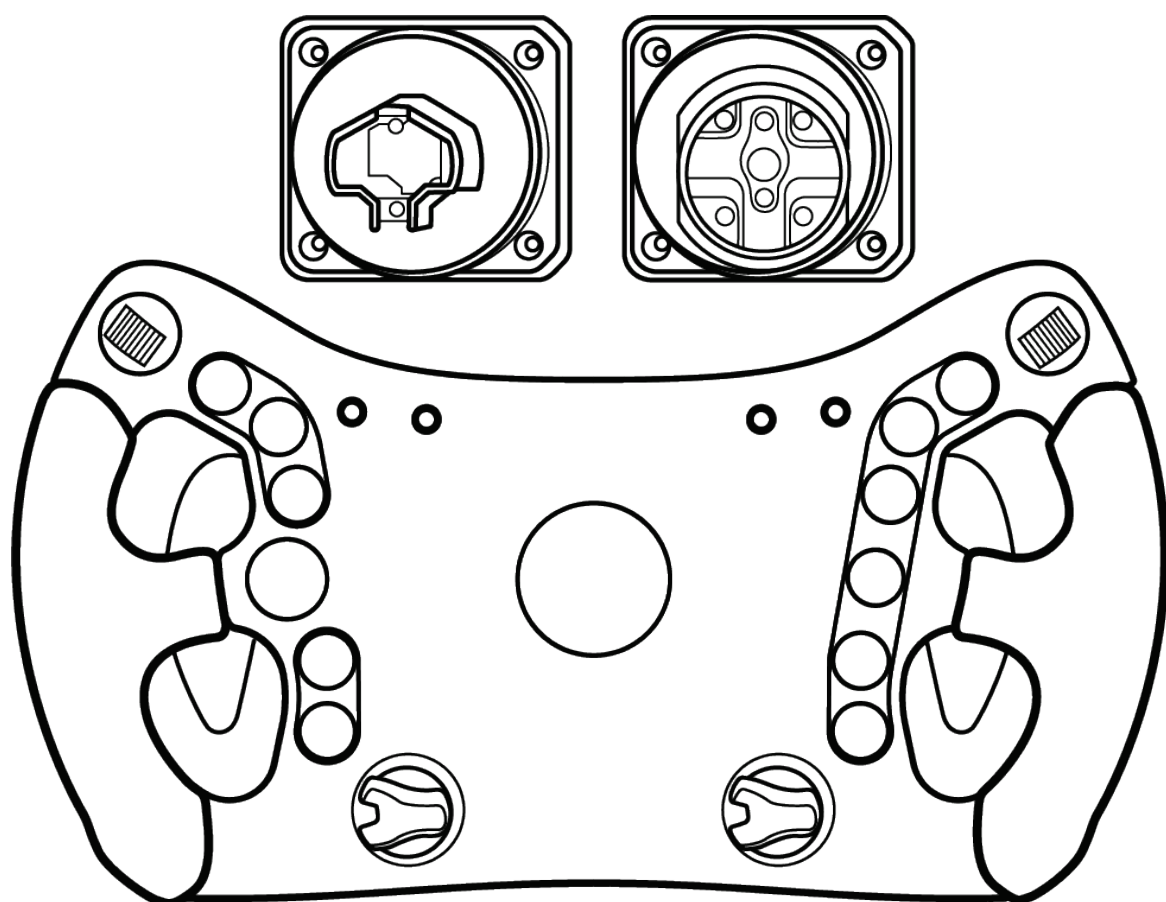



2. Funktionen

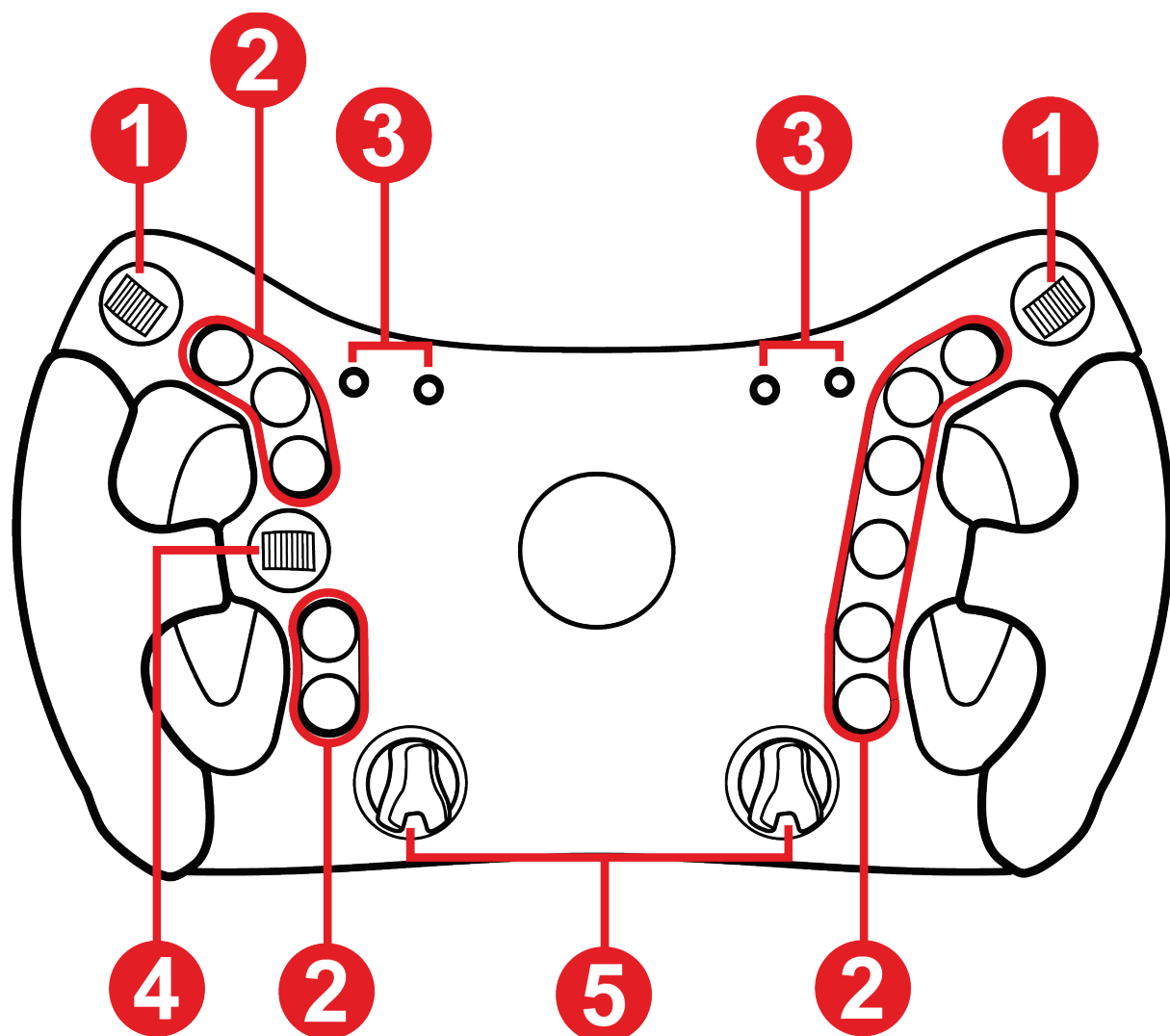

- ❶ Daumen-Encoder
- ❷ 11 Aktionstasten
- ❸ RPM-LEDs und Renndaten (Flaggen, Boxen)
- ❹ D-Pad
- ❺ Dreh-Encoder

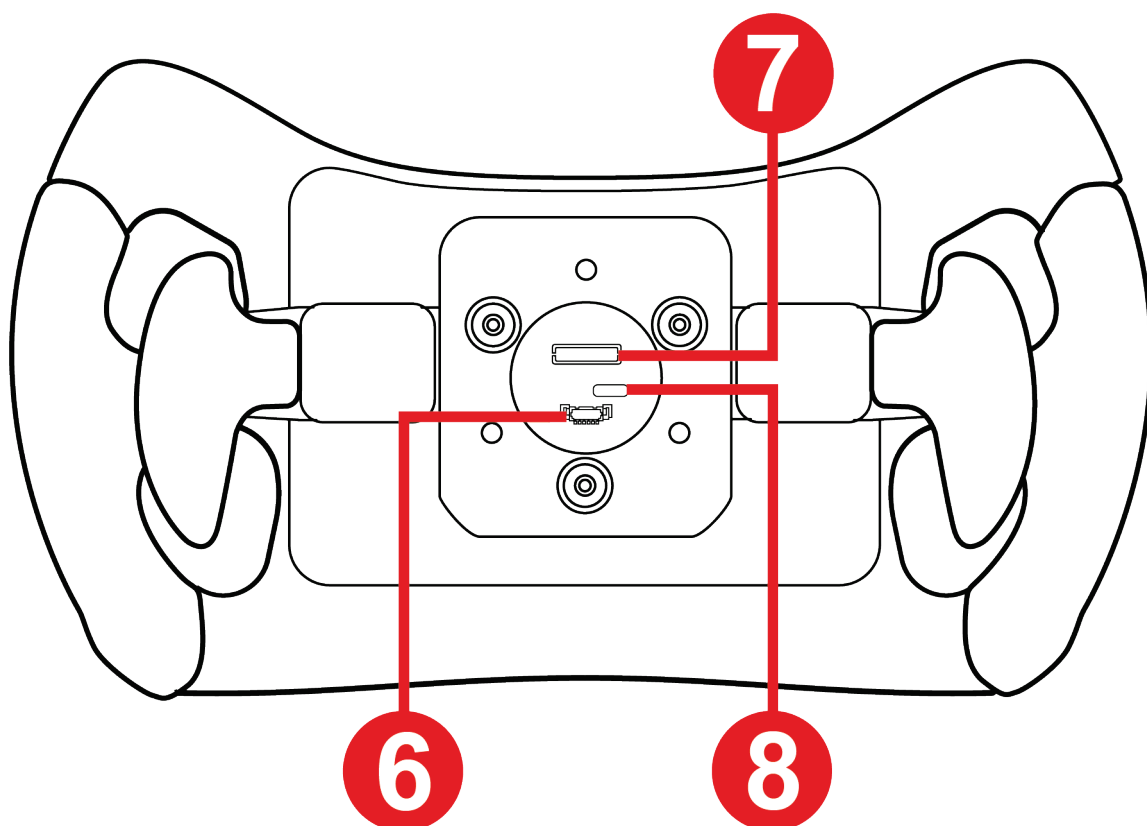

⑥ Anschluss für Quick Release-Halterung mit Schraubbasis

⑦ Anschluss für Quick Release-Halterung mit Verriegelungsbasis

⑧ USB-C-Anschluss (falls ein Firmware-Update erforderlich ist – Kabel nicht enthalten)

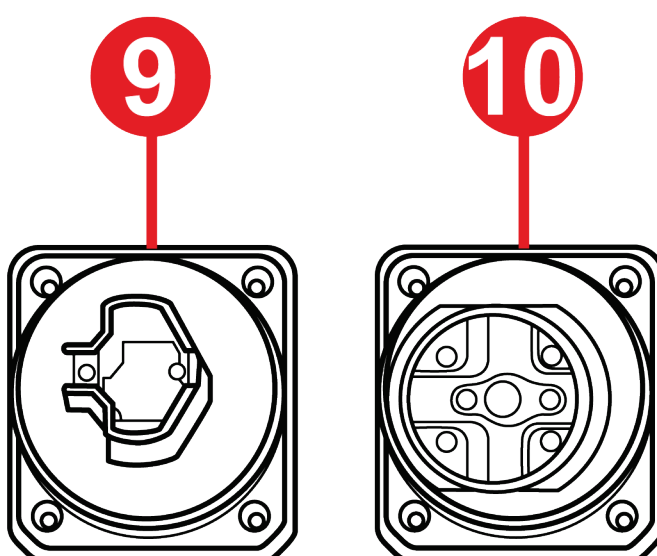

⑨ Anschluss für Quick Release-Halterung mit Verriegelungsbasis

⑩ Anschluss für Quick Release-Halterung mit Schraubbasis



3. Informationen zur Verwendung des Lenkrads



Dokumentation

Bevor Sie dieses Produkt verwenden, lesen Sie diese Dokumentation noch einmal sorgfältig durch und bewahren Sie diese auf, damit Sie später darin nachschlagen können.



Stromschlag

- Bewahren Sie dieses Produkt an einem trockenen Ort auf, und setzen Sie es weder Staub noch Sonnenlicht aus.
- Ziehen Sie nicht an den Anschlüssen und Kabeln, und verdrehen Sie diese nicht.
- Befolgen Sie die Anweisungen zum Herstellen von Anschlüssen.
- Schütten Sie keine Flüssigkeiten auf das Gerät oder seine Anschlüsse.
- Schließen Sie das Produkt nicht kurz.
- Zerlegen Sie das Produkt nicht (mit Ausnahme der in diesem Handbuch beschriebenen kundenspezifischen Anpassungen), werfen Sie es nicht in ein Feuer und setzen Sie es keinen hohen Temperaturen aus.
- Öffnen Sie das Gerät nicht: Im Inneren befinden sich keine vom Benutzer zu wartenden Teile. Jegliche Reparaturen müssen vom Hersteller, einer autorisierten Stelle oder einem qualifizierten Techniker durchgeführt werden.



Absicherung des Spielbereichs

- Legen Sie keine Gegenstände in den Spielbereich, die den Benutzer in seiner Tätigkeit stören oder eine unerwünschte Handlung oder eine Störung durch eine andere Person herbeiführen könnten (z. B. Kaffeetasse, Telefon, Schlüssel).
- Decken Sie die Stromkabel nicht mit Teppichen oder Läufern, Decken oder anderen Gegenständen ab und verlegen Sie keine Kabel dort, wo Personen entlanglaufen.



Verletzungen im Zusammenhang mit sich wiederholenden Fahrbewegungen

Die Verwendung einer Gangschaltung kann zu Muskel- oder Gelenkschmerzen führen. So lassen sich Probleme vermeiden:

- Wärmen Sie sich vorher auf und vermeiden Sie es, über einen längeren Zeitraum zu spielen.
- Legen Sie nach jeder Stunde Spielzeit eine 10- bis 15-minütige Pause ein.
- Sollten Sie Ermüdungserscheinungen oder Schmerzen in Händen, Handgelenken, Armen, Füßen oder Beinen verspüren, drücken Sie die Taste, um das Force Feedback auszuschalten, schalten Sie die Basis aus und ruhen Sie sich ein paar Stunden lang aus, bevor Sie wieder mit dem Spiel beginnen.
- Wenn die oben beschriebenen Symptome oder Schmerzen bei der Wiederaufnahme des Spiels weiterhin bestehen, hören Sie auf zu spielen und suchen Sie Ihren Arzt auf.
- Stellen Sie das Force Feedback nicht auf einen Wert ein, der im Verhältnis zu Ihrer Erfahrung und Ihrer körperlichen Verfassung zu hoch ist.
- Bewahren Sie das Gerät außerhalb der Reichweite von Personen unter 16 Jahren auf.



- Vergewissern Sie sich, dass die Basis der Schaltung entsprechend den Anweisungen in diesem Handbuch richtig befestigt sind.

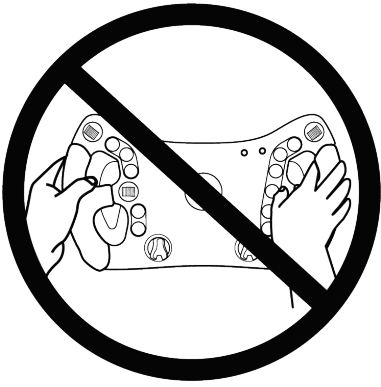

Gefahr von unvorhergesehenen, heftigen und schnellen Drehungen: Stecken Sie niemals eine Hand oder einen Arm durch die Öffnungen des Lenkrads oder in den Drehbereich des Lenkrads.

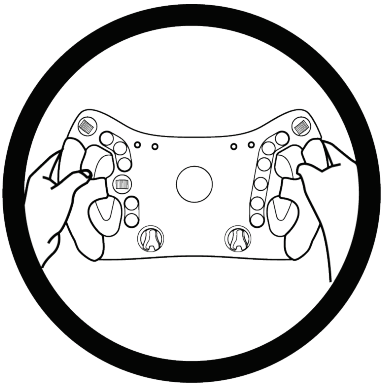

Lassen Sie bei der Benutzung des Produkts immer beide Hände korrekt auf dem Lenkrad liegen, ohne es jemals ganz loszulassen.



Das Produkt darf nur von Personen bedient werden, die **mindestens 16 Jahre alt sind.**



4. Montage der Quick Release-Halterung

Das **Ferrari 488 GT3 Wheel Add-On** wird mit zwei Quick Release-Halterungen geliefert, die auf die jeweiligen Basis-Formate von Thrustmaster abgestimmt sind.

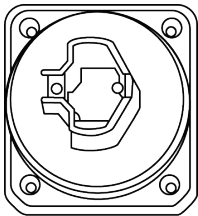
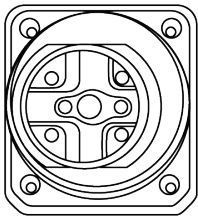
System	Kompatibilität
 Quick Release-Halterung für Verriegelungsbasis	T818, T818 Ferrari SF1000 Simulator und zukünftige Thrustmaster-Basen.
 Quick Release-Halterung für Schraubbasis	T-GT / T-GT II Servo Base, T300 RS Servo Base, TS PC Racer, TS-XW, TX Racing Wheel Servo Base, TS-XW Servo Base.



Überprüfen Sie vor jedem Gebrauch, ob das **Ferrari 488 GT3 Wheel Add-On** noch ordnungsgemäß an der Halterung befestigt ist, wie es im Benutzerhandbuch der Basis angegeben ist.



Montage der Quick Release-Halterung für Verriegelungsbasis

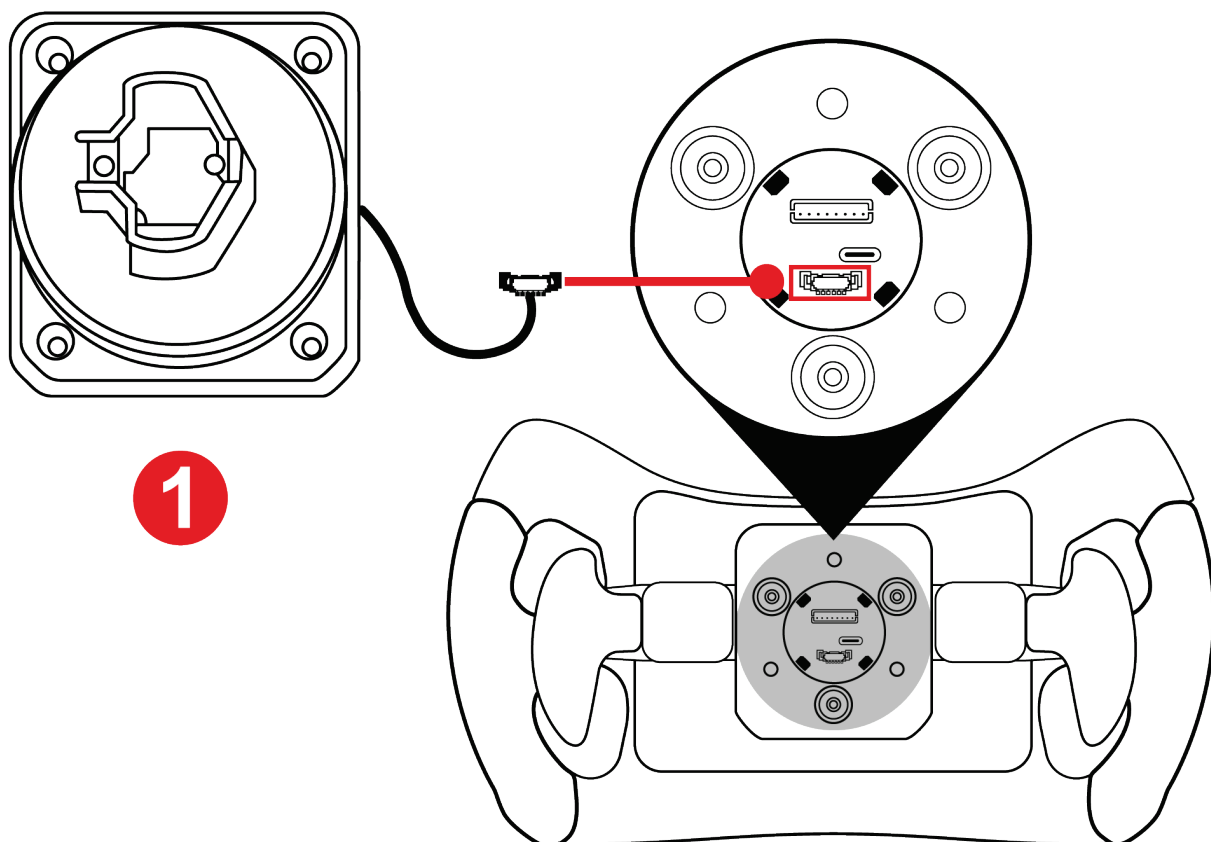

1 Stecken Sie den Stecker der Quick Release-Halterung in den entsprechenden Anschluss auf der Rückseite des Lenkrads.



Um ein Einklemmen des Kabels zu vermeiden, stecken Sie dieses in das Gehäuse zurück, bevor Sie die Halterung anschrauben.

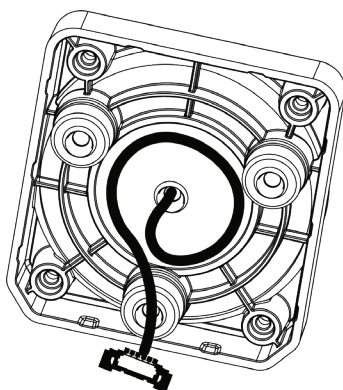

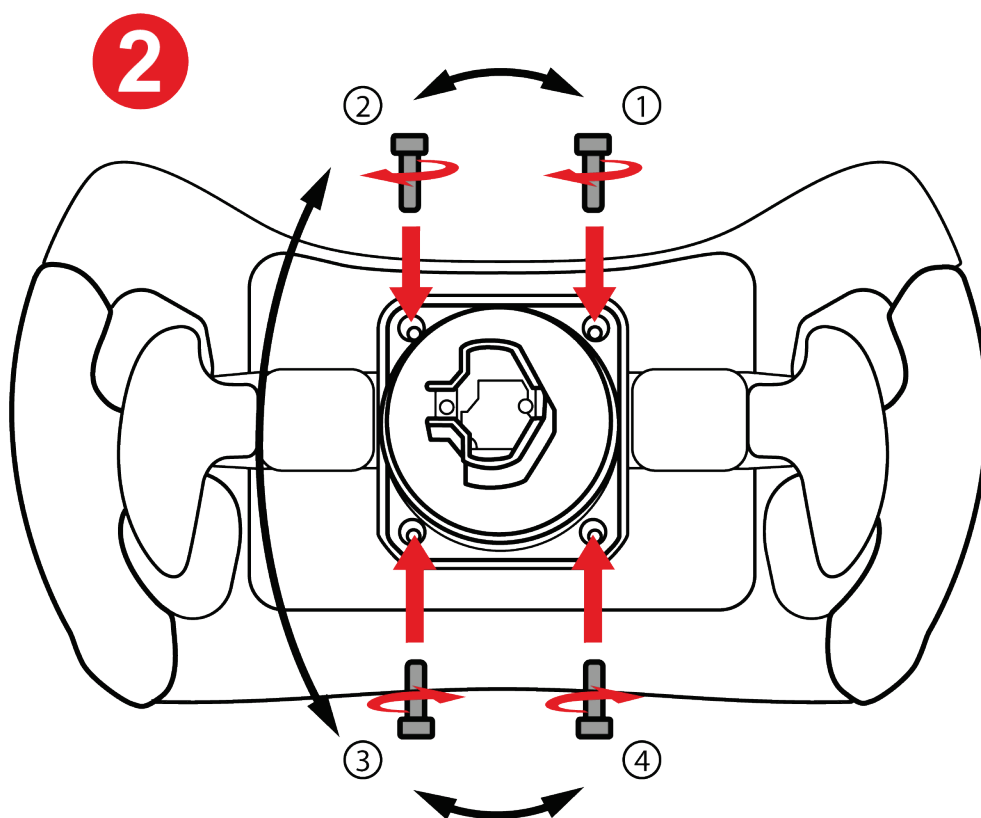

2 Setzen Sie die Quick Release-Halterung ein und ziehen Sie diese mit dem mitgelieferten Torx-Schlüssel fest.



Ziehen Sie die Schrauben bei der Montage der Halterung nicht zu fest an.

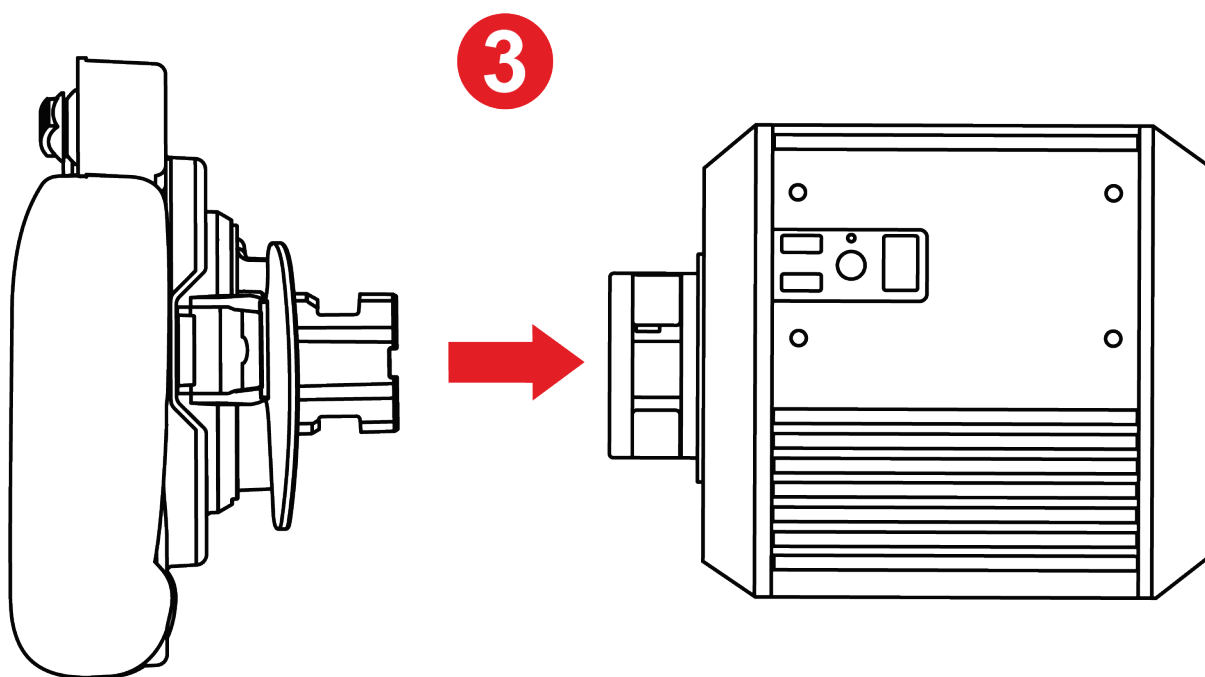

3 Bringen Sie das Lenkrad an der Basis an.



Befolgen Sie das im Benutzerhandbuch der Basis vorgegebene Montageverfahren.



Montage der Quick Release-Halterung für Schraubbasis

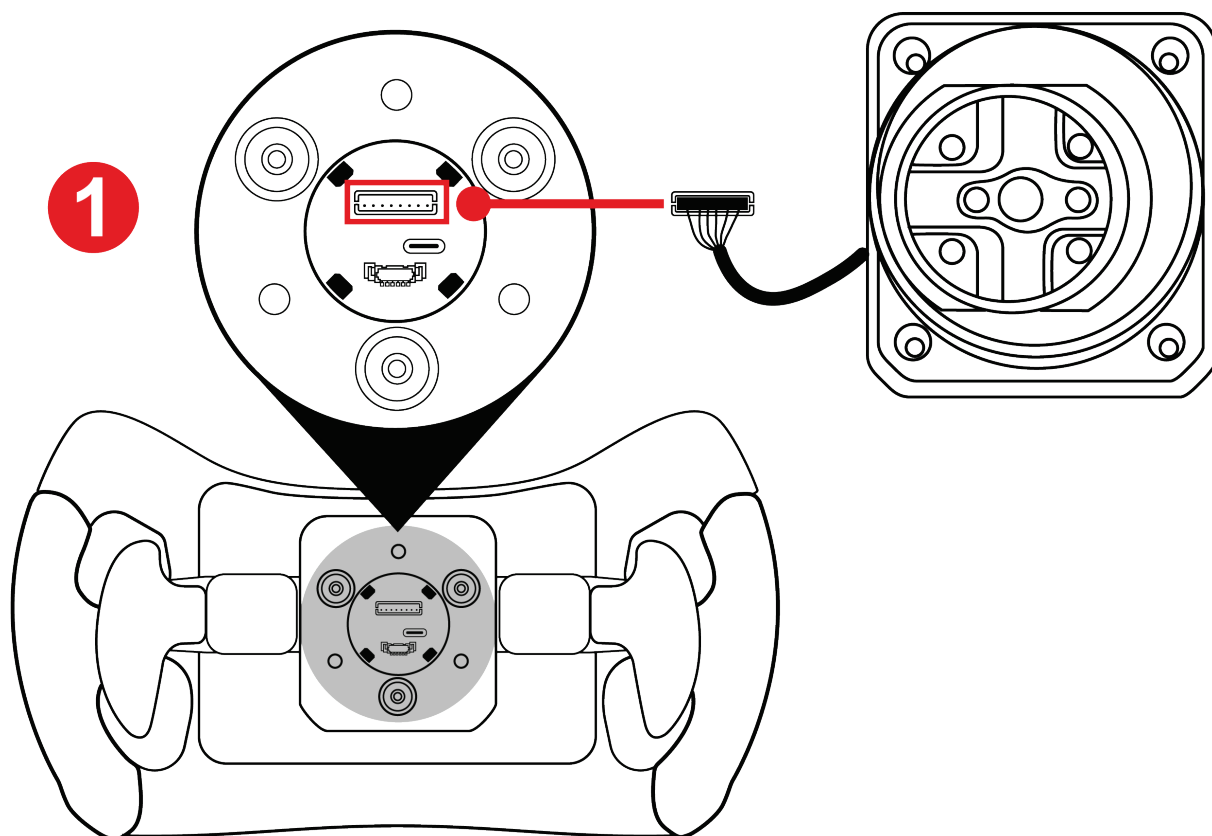

1 Stecken Sie den Stecker der Quick Release-Halterung in den entsprechenden Anschluss auf der Rückseite des Lenkrads.



Um ein Einklemmen des Kabels zu vermeiden, stecken Sie dieses in das Gehäuse zurück, bevor Sie die Halterung anschrauben.

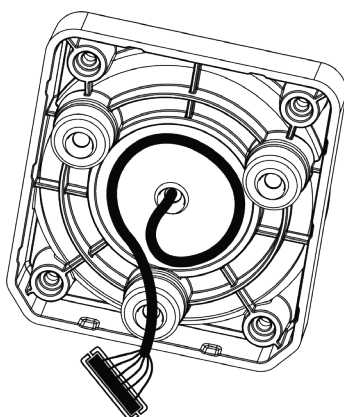

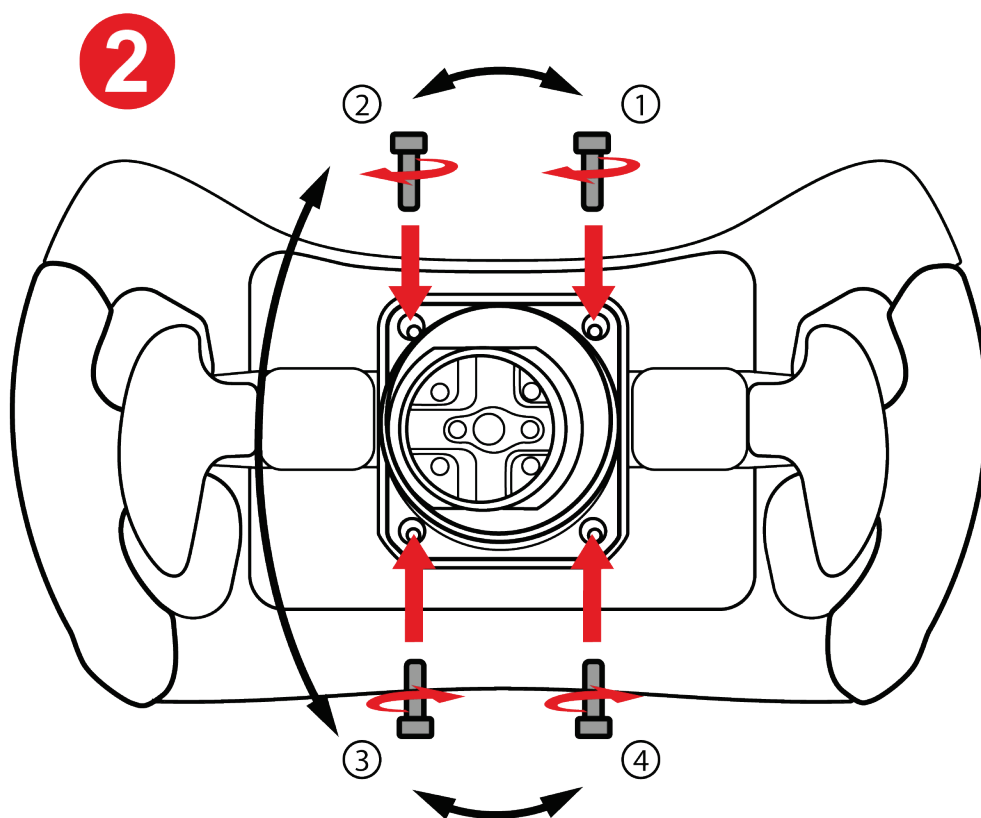

2 Setzen Sie die Quick Release-Halterung ein und ziehen Sie diese mit dem mitgelieferten Torx-Schlüssel fest.



Ziehen Sie die Schrauben bei der Montage der Halterung nicht zu fest an.

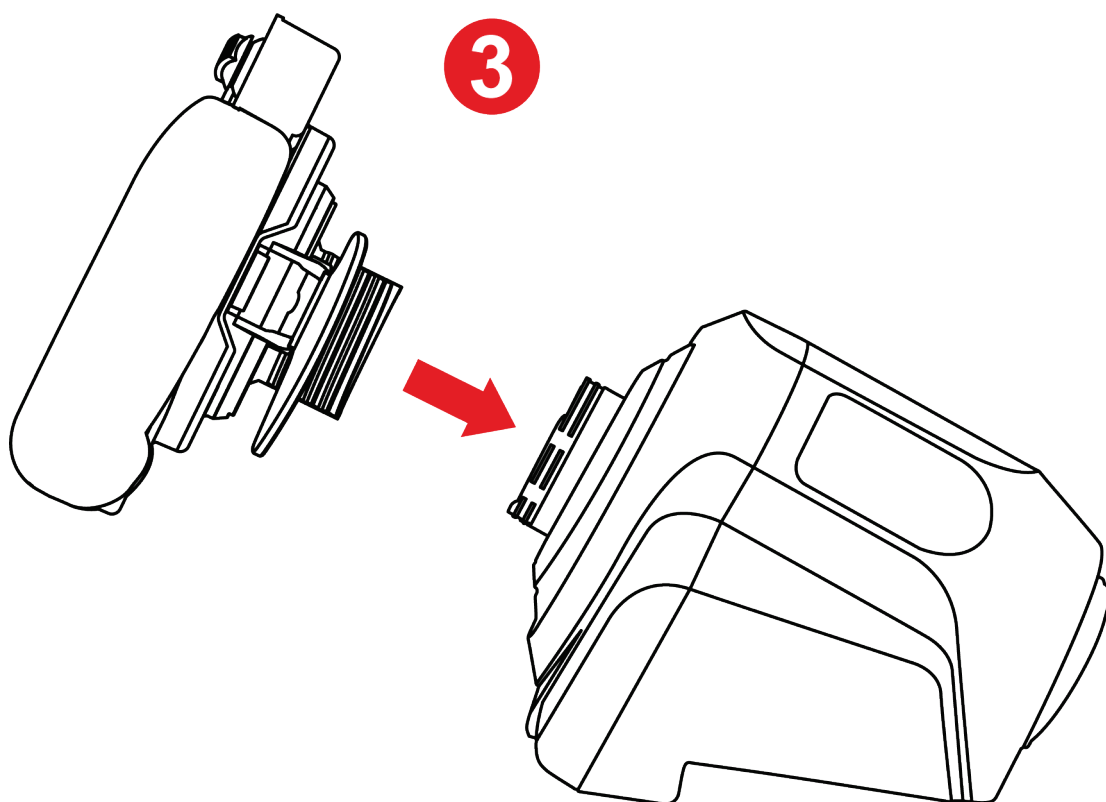

3 Bringen Sie das Lenkrad an der Basis an.



Befolgen Sie das im Benutzerhandbuch der Basis vorgegebene Montageverfahren.



Schließen Sie den Quick Release-Adapter (im Lieferumfang der T818-Basis enthalten und separat erhältlich) auf keinen Fall an die Quick Release-Halterung für die Schraubbasis an, wenn Sie diesen an einer T818-Basis verwenden möchten.

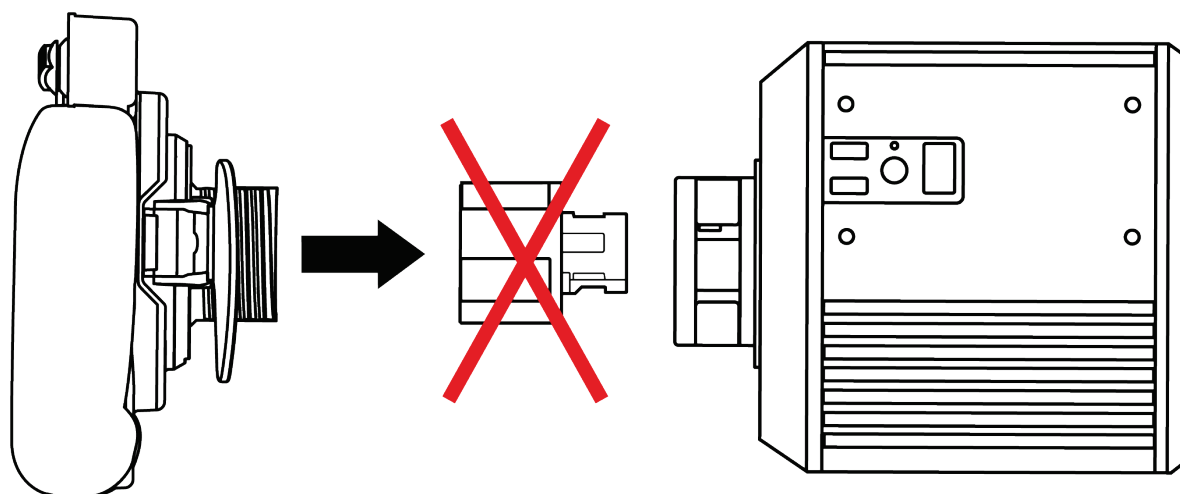
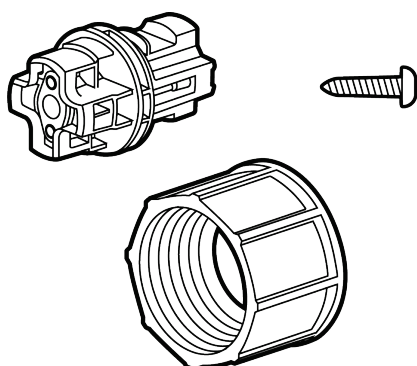

Für die Verwendung an einer T818-Basis oder einer Basis, die mit einem Anschluss für eine Verriegelungsbasis ausgestattet ist, darf nur die **Quick Release-Halterung für die Verriegelungsbasis** benutzt werden, die mit dem **Ferrari 488 GT3 Wheel Add-On** geliefert wird.



5. Mapping

Mapping für PC

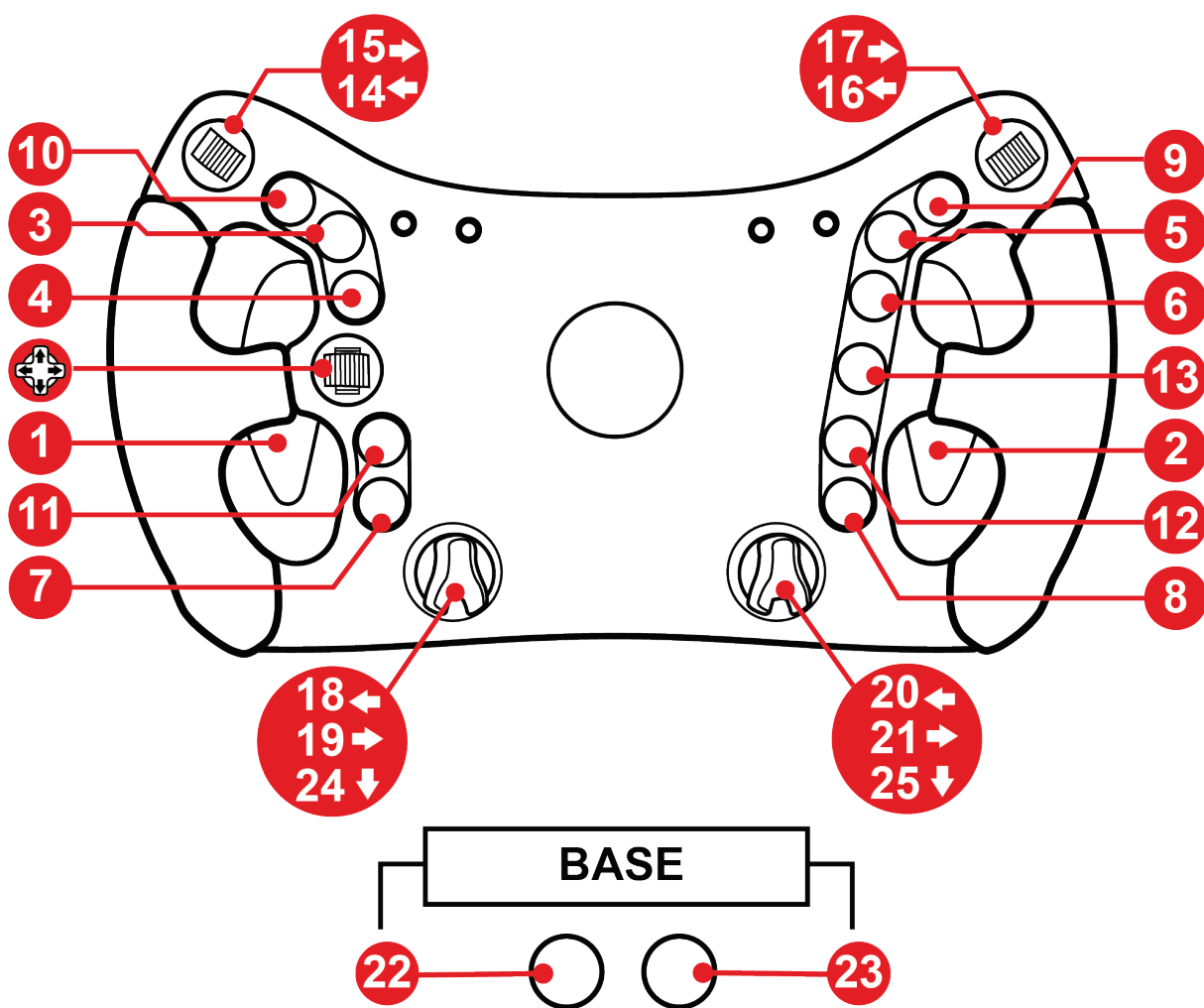



Mapping für PS4™/PS5™

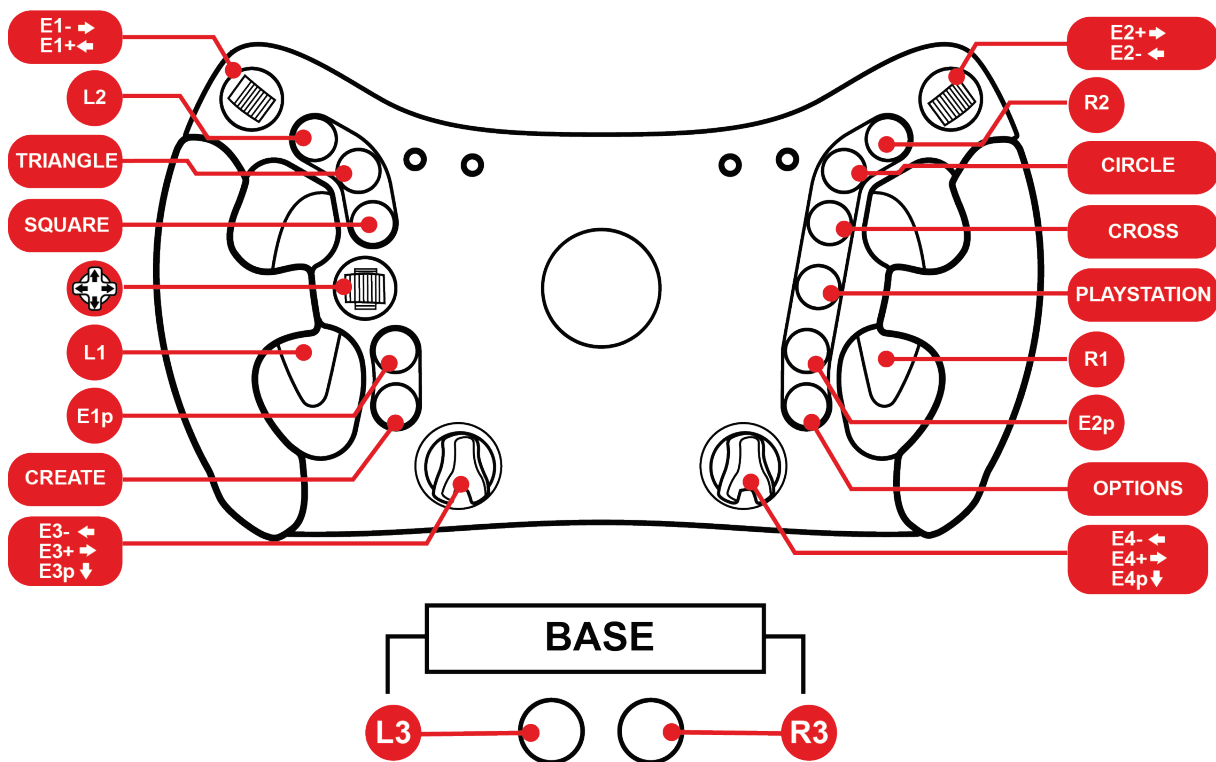



Mapping für Xbox Series/Xbox One

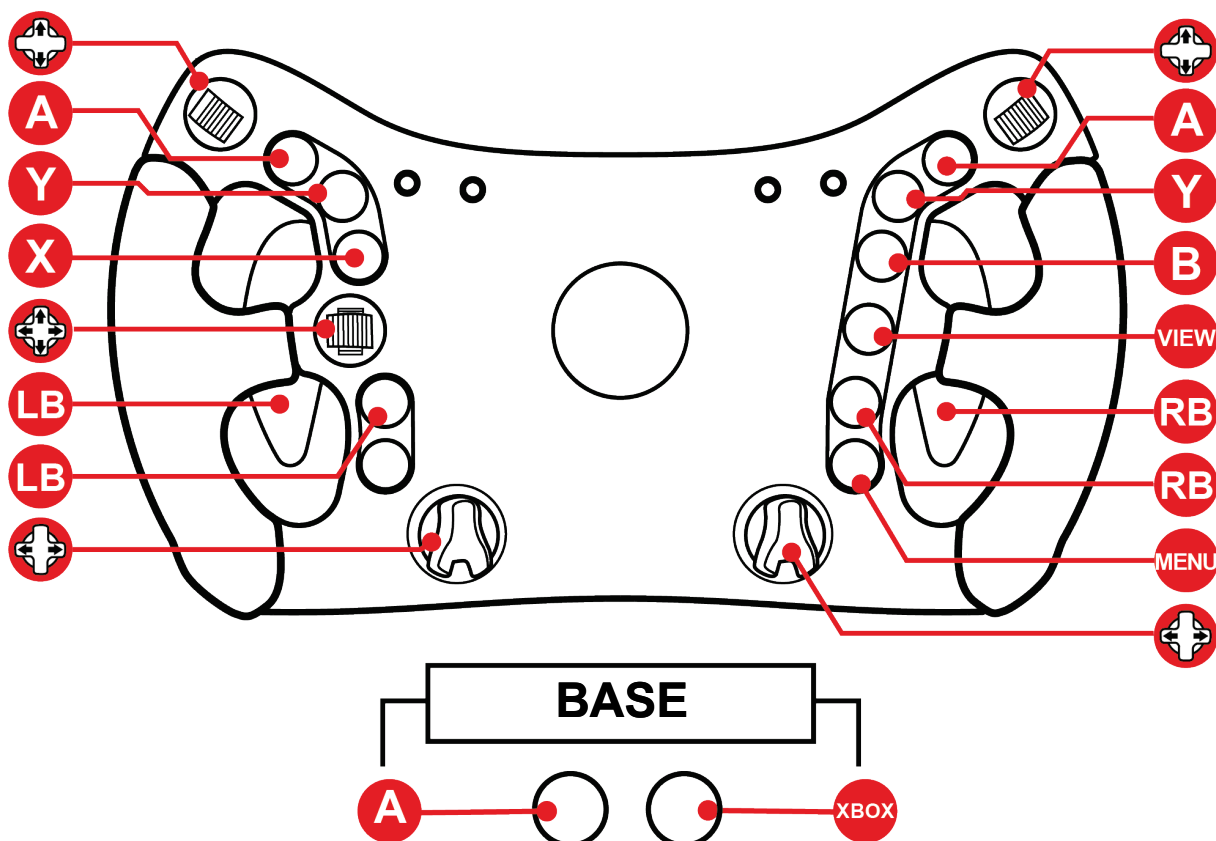

Für Xbox Series und Xbox One gilt:

- Die LEDs auf dem Ferrari 488 GT3 Wheel Add-On sind aufgrund von Einschränkungen des Konsolenprotokolls nicht funktionsfähig.
- Einige Funktionen (Encoder, Anzahl der Tasten) sind durch das Konsolenprotokoll begrenzt.



6. Funktionsweise der LEDs

Das **Ferrari 488 GT3 Wheel Add-On** zeigt die Renndaten über die LEDs an: Flagge, Box und RPM.

Die angezeigten Daten können individuell angepasst werden (Intensität und Farbe der RPM-LEDs), je nach Modus (GT3 oder Formula).

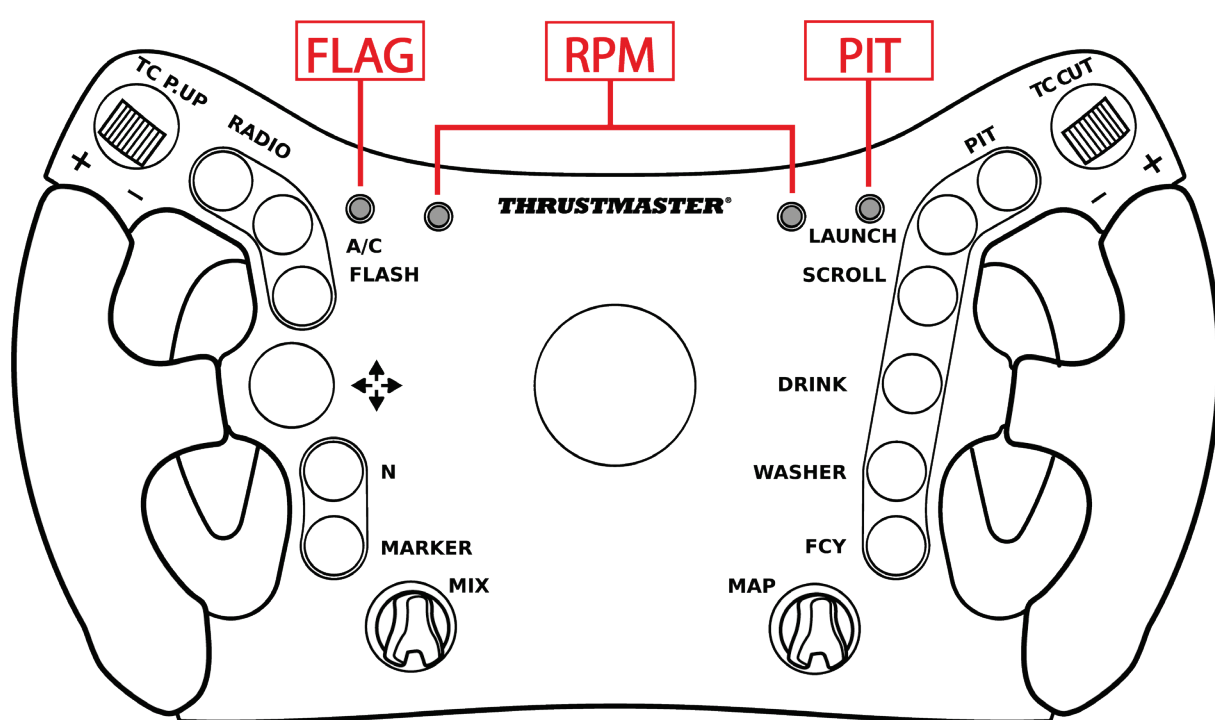

Die LEDs funktionieren auf PC und PS4™/PS5™.

Auf Xbox Series und Xbox One sind die LEDs aufgrund von Konsolenprotokollbeschränkungen nicht funktionsfähig.



Aufrufen/Verlassen des LED-Menüs

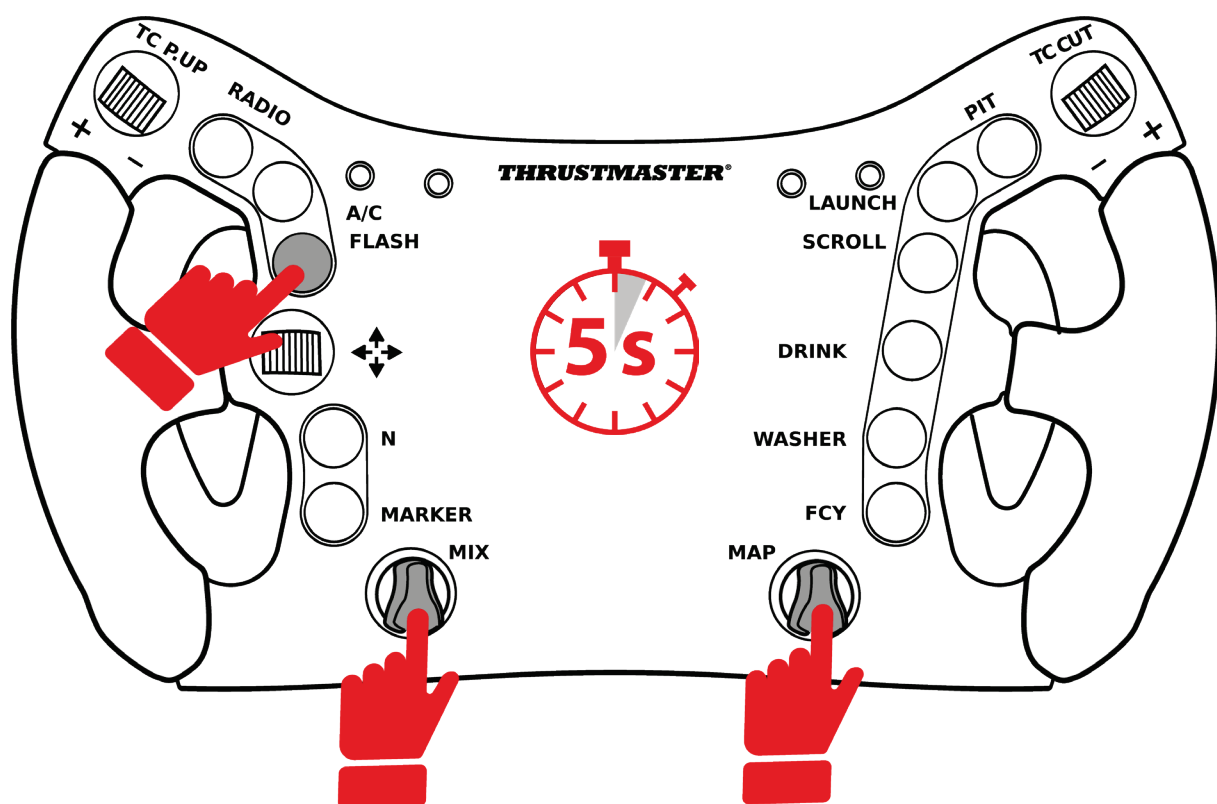

- Um das LED-Menü aufzurufen, drücken Sie gleichzeitig die **FLASH**-Taste und beide **Dreh-Encoder** für **5 Sekunden** und lassen Sie diese anschließend los.

- Um das LED-Menü zu verlassen, drücken Sie gleichzeitig die **FLASH**-Taste und beide **Dreh-Encoder**, und lassen Sie diese anschließend los.



FLAG

RPM

PIT



Aufrufen des LED-Menüs: Die FLAG- und PIT-LEDs und eine der RPM-LEDs (rot auf der linken Seite oder blau auf der rechten Seite) leuchten auf.



Verlassen des LED-Menüs: Alle vier LEDs erlöschen.



Einstellung der LED-Intensität

- Rufen Sie das LED-Menü auf, indem Sie die **FLASH-Taste** und beide **Dreh-Encoder** gleichzeitig 5 Sekunden lang gedrückt halten und dann loslassen.
- Drehen Sie den **linken Encoder (MIX)** nach links, um die Intensität zu verringern, oder nach rechts, um die Intensität zu erhöhen.



- Verlassen Sie das LED-Menü durch gleichzeitiges Drücken der **FLASH-Taste** und beider **Dreh-Encoder** und lassen Sie diese dann los.



Änderung des LED-Modus: GT3 oder Formula

- Rufen Sie das LED-Menü auf, indem Sie die **FLASH-Taste** und beide **Dreh-Encoder gleichzeitig 5 Sekunden** lang gedrückt halten und dann loslassen.
- Drehen Sie den **rechten Encoder (MAP)** nach links, um den GT3-Modus (rote LED) zu wählen, oder nach rechts, um den Formula-Modus (blaue LED) zu wählen.



GT3-Modus (Standardmodus)



FORMULA-Modus

- Verlassen Sie das LED-Menü durch gleichzeitiges Drücken der **FLASH-Taste** und beider **Dreh-Encoder** und lassen Sie diese dann los.



7. Individuelle Anpassung der Schaltwippen

Die Schaltwippen des **Ferrari 488 GT3 Wheel Add-On** sind in ihrem **Abstand** und in ihrer **Griffweite** einstellbar.

Der **Abstand** besteht in der Anpassung der Schaltwippen in der Weite, wodurch der Abstand zwischen dem Griff und der Schaltwippe verändert wird.

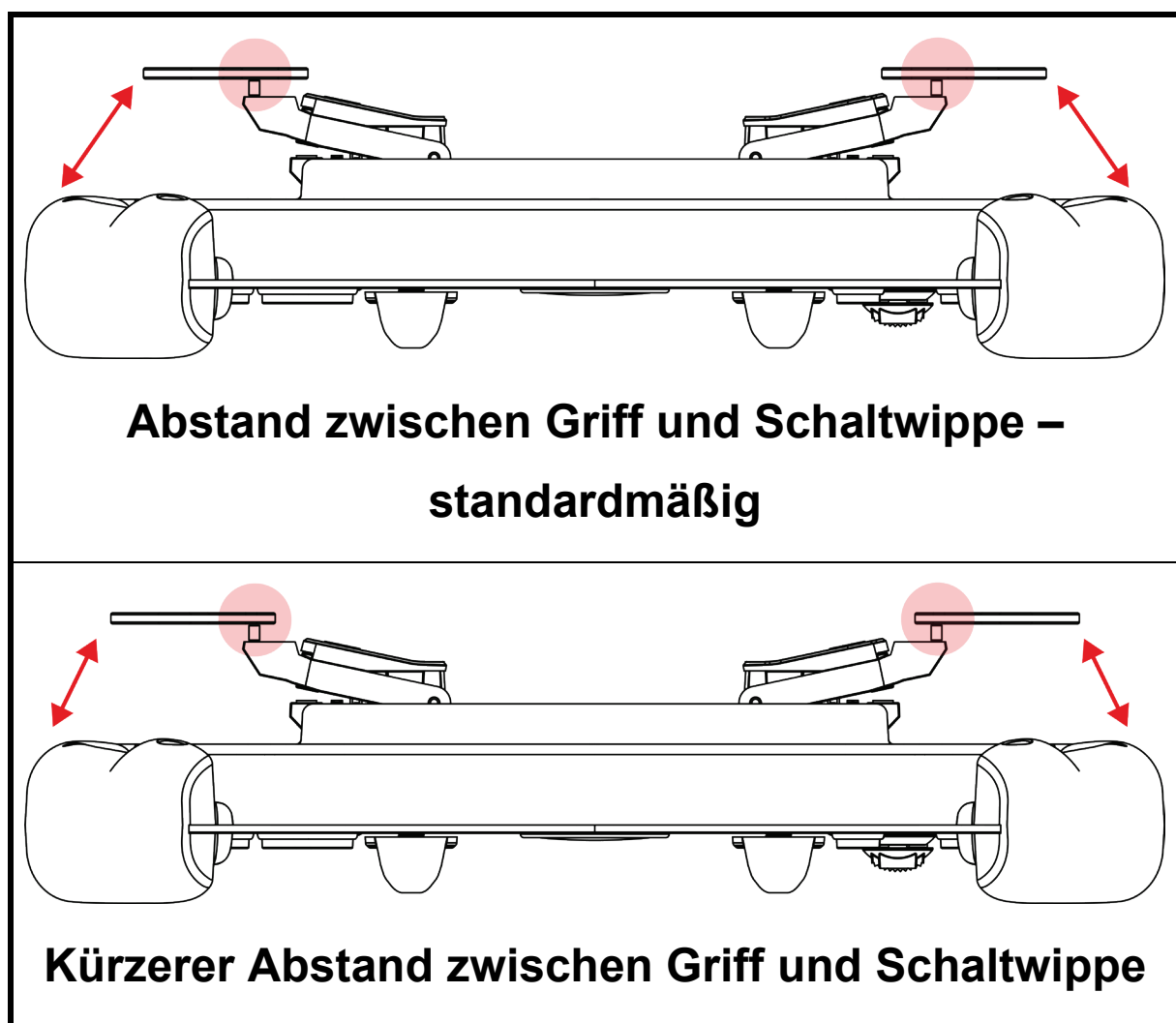



Durch die Anpassung der **Griffweite** mit Hilfe der Abstandshalter wird der Aktivierungsweg der Schaltwippen verändert.

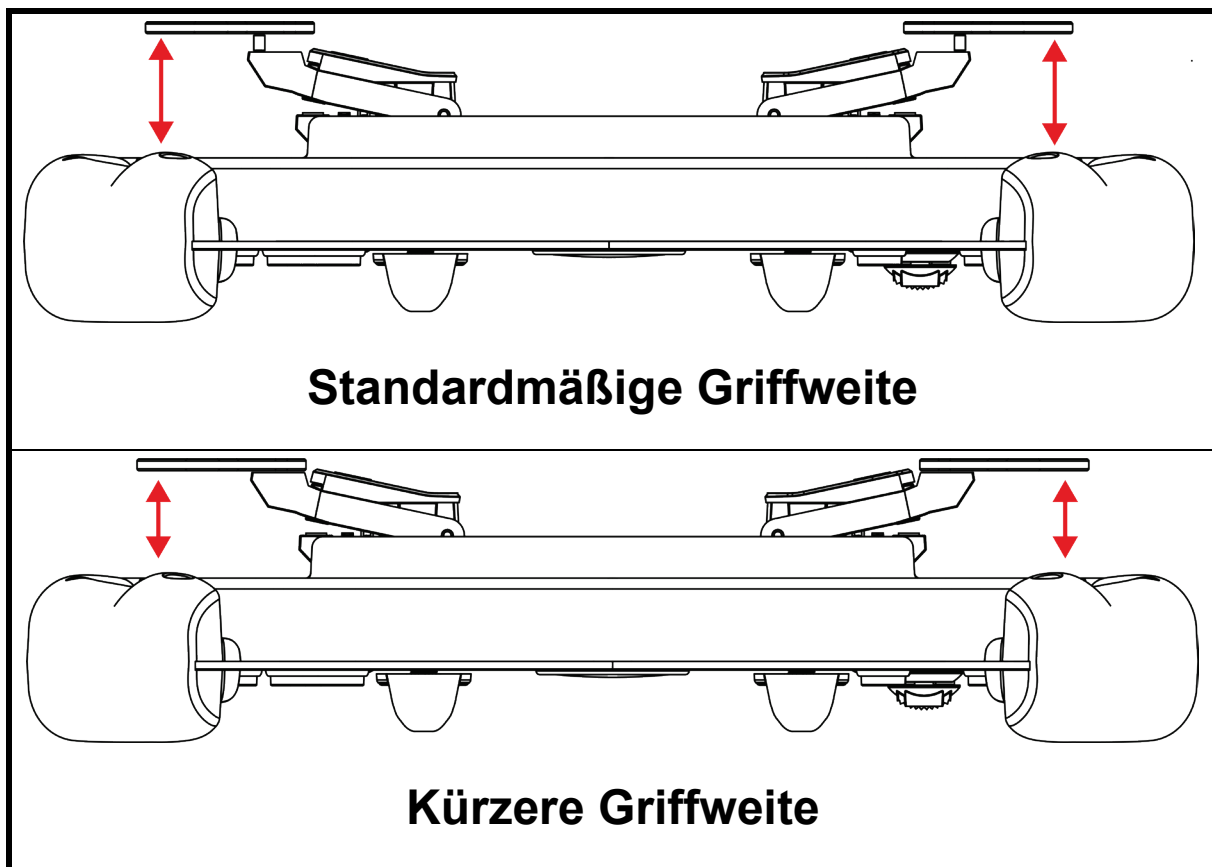

Es ist auch möglich, die **magnetische Sensitivität** und den **Geräuschpegel** der Schaltwippen mit Hilfe der mitgelieferten Pads einzustellen.

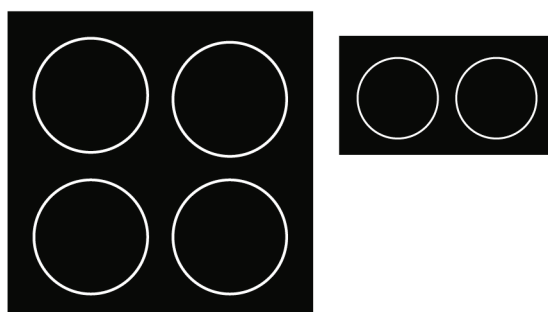



Anpassung des Abstandes der Schaltwippen

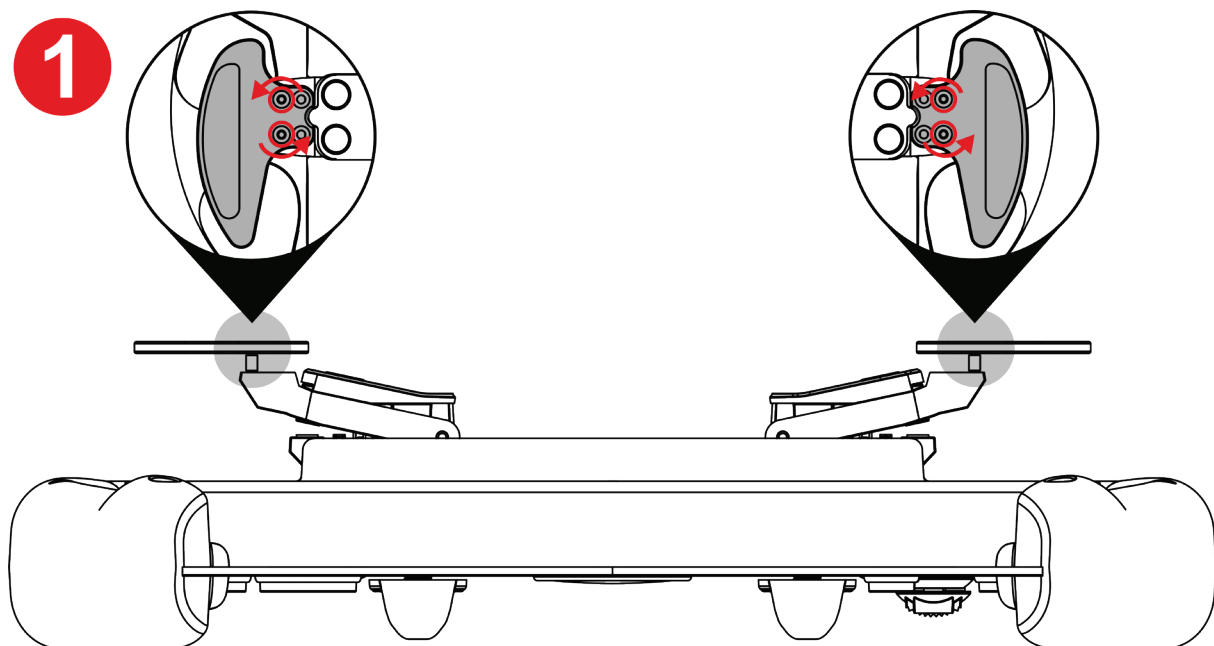

1 Lösen Sie die vier Schrauben der Schaltwippe mit dem mitgelieferten Torx-Schlüssel.

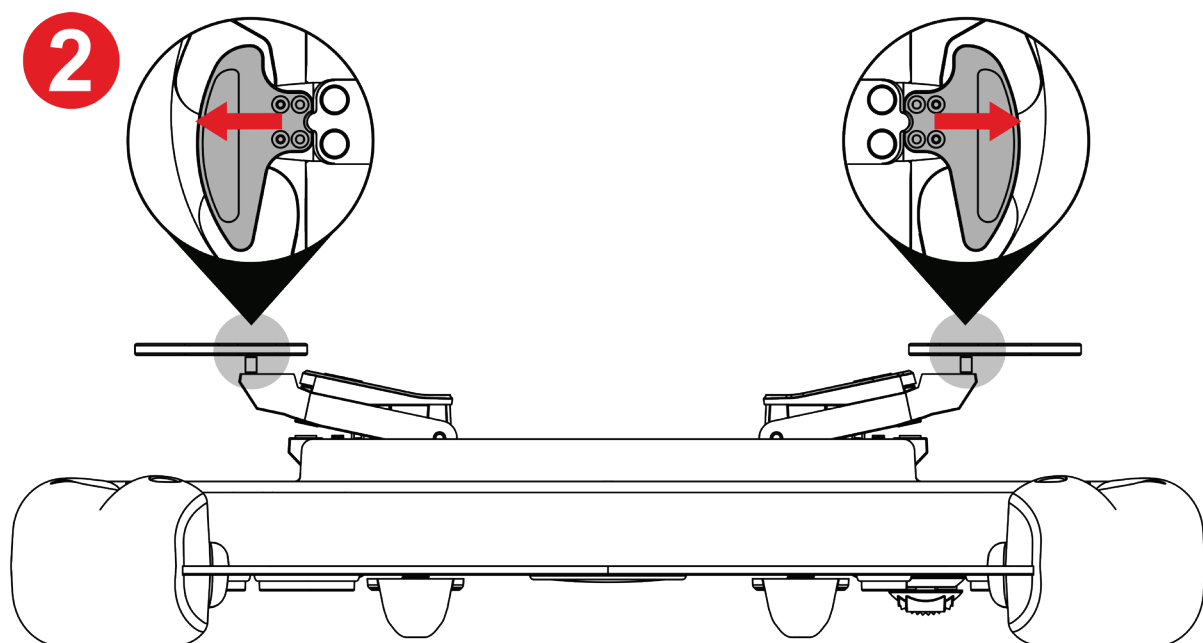

2 Schieben Sie die Schaltwippen nach außen, so dass sie mit den Löchern übereinstimmen.

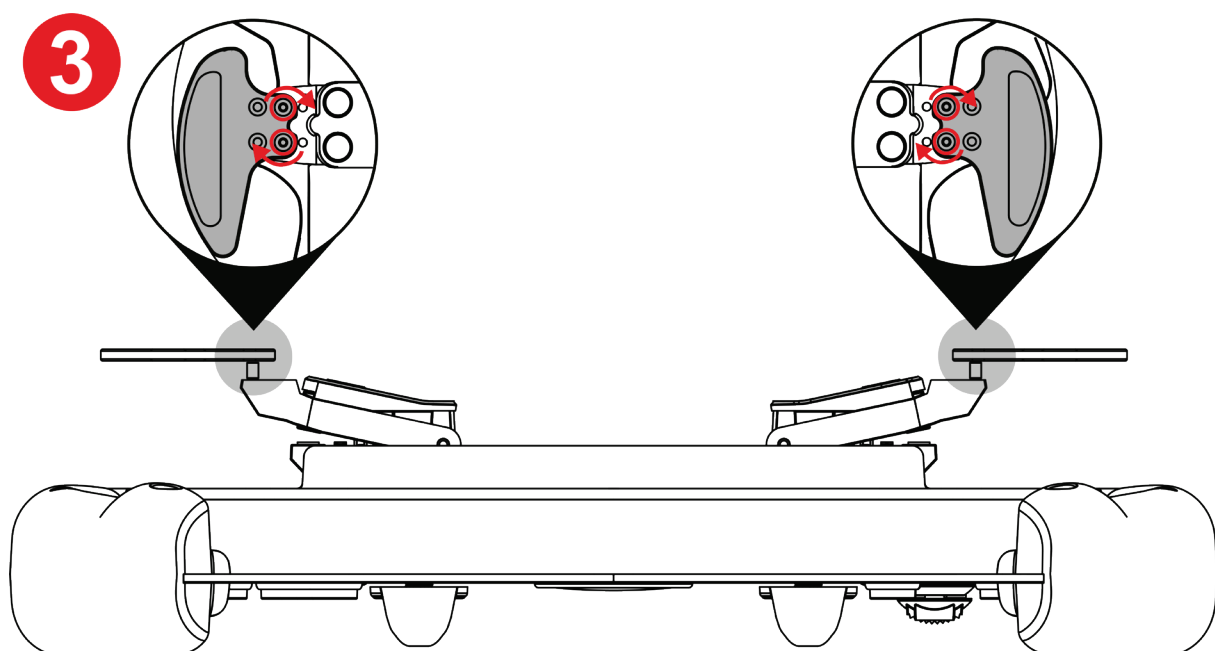

3 Ziehen Sie die vier Schrauben der Schaltwippe mit dem mitgelieferten Torx-Schlüssel wieder an.



Anpassung der Griffweite der Schaltwippen

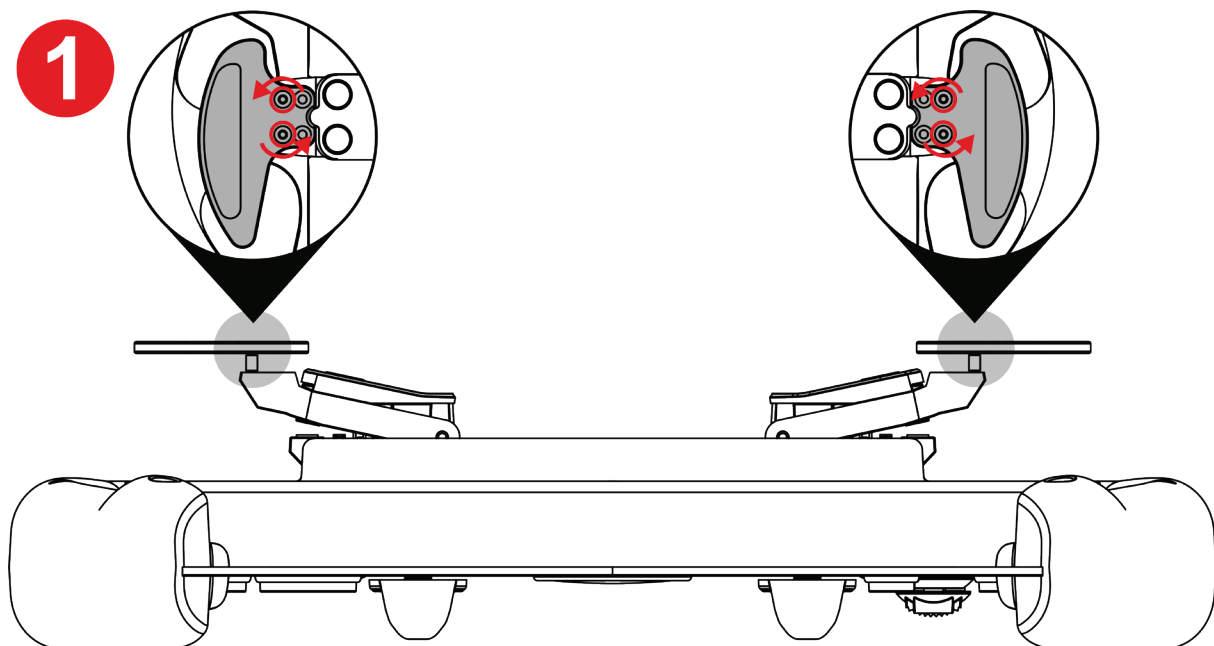

1 Lösen Sie die vier Schrauben der Schaltwippe mit dem mitgelieferten Torx-Schlüssel.

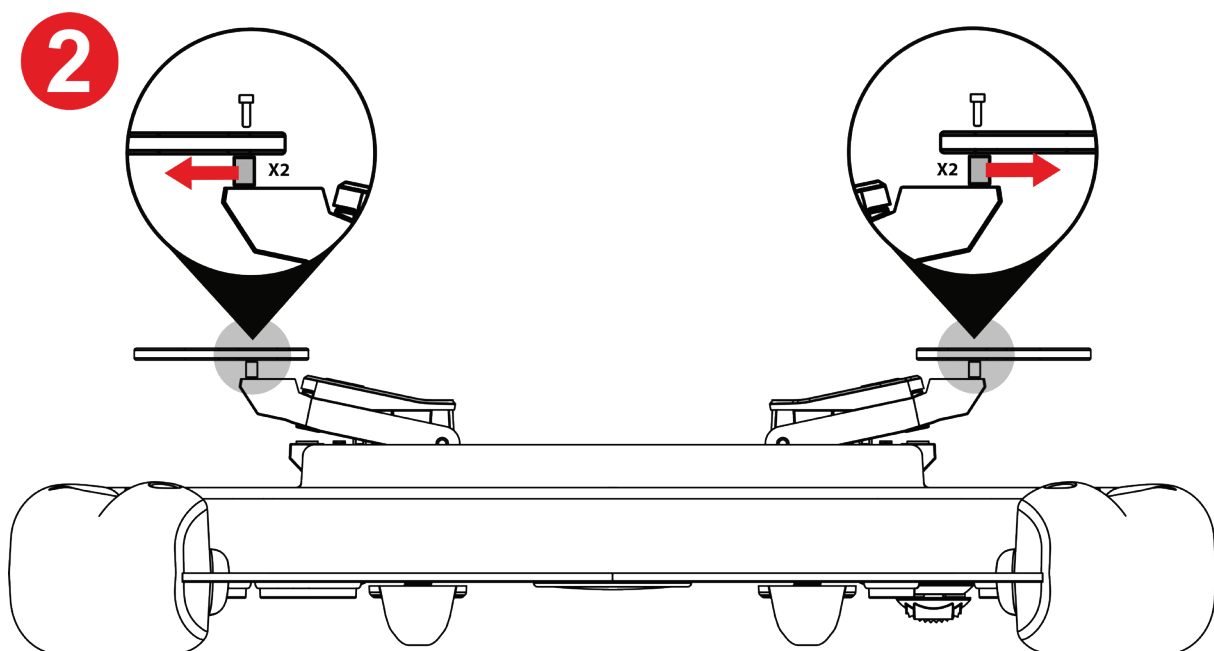

2 Entfernen Sie die Abstandshalter.

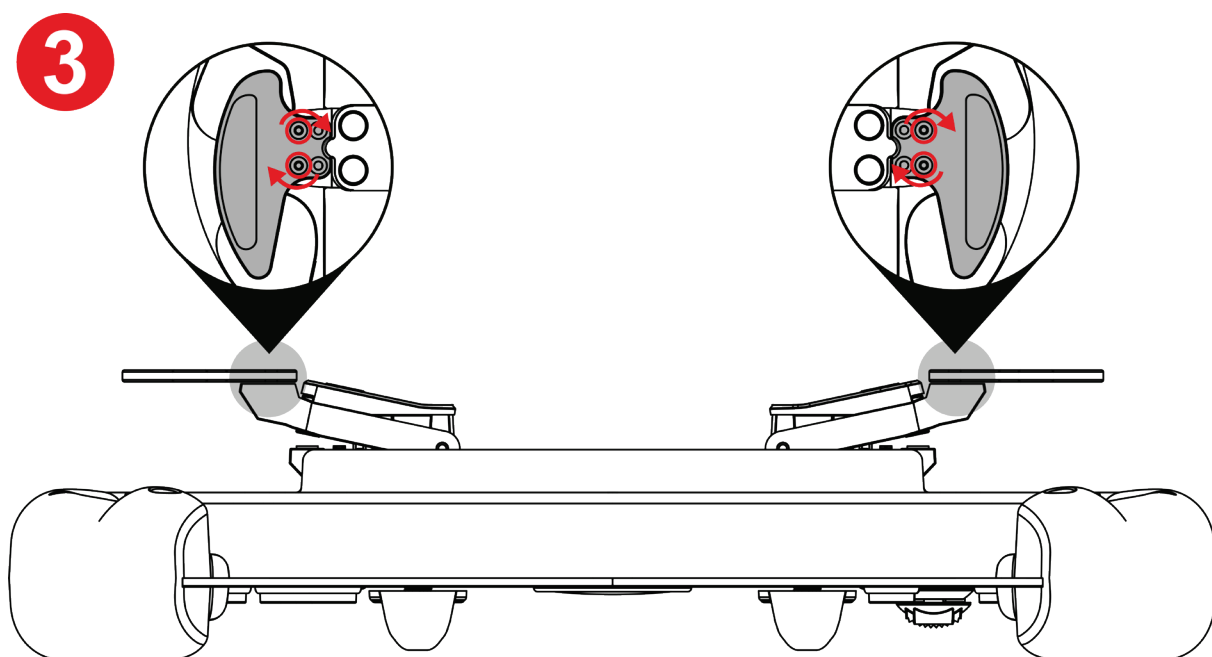

3 Ziehen Sie die vier Schrauben der Schaltwippe mit dem mitgelieferten Torx-Schlüssel wieder an.



Einstellen der magnetischen Sensitivität und des Geräuschpegels der Schaltwippen

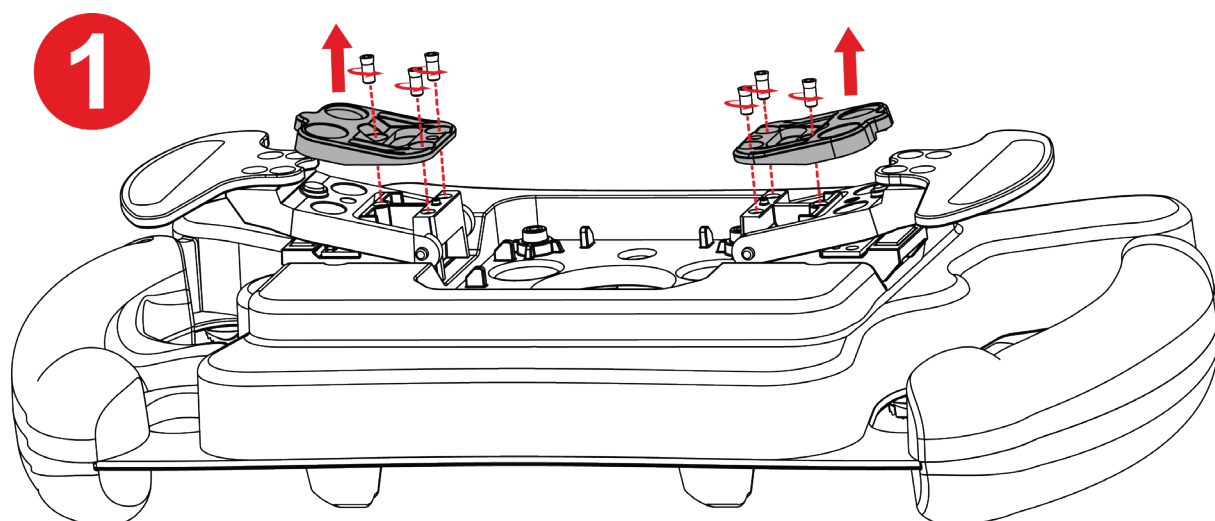

1 Entfernen Sie die Magnet-Anschläge, indem Sie die sechs Anschlagsschrauben mit dem mitgelieferten Torx-Schlüssel herausdrehen.

2

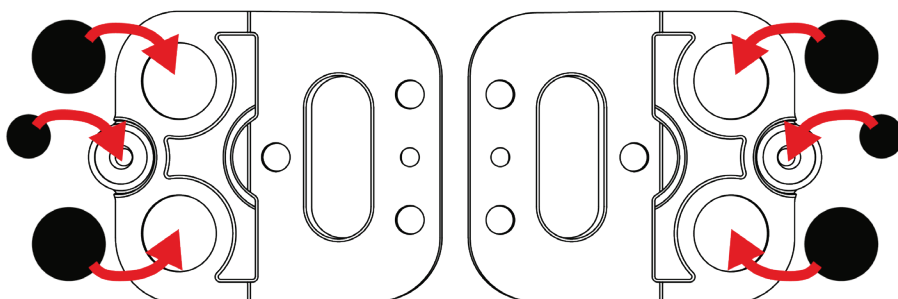
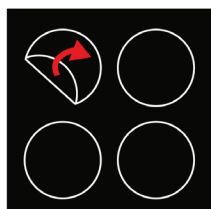

2 Lösen Sie die mitgelieferten Pads ab und bringen Sie sie an den entsprechenden Stellen unter den Magnet-Anschlägen an.



Mögliche Konfigurationen und deren Auswirkungen finden Sie in der Tabelle **Magnetische Sensitivität und Geräuschdämpfung der Schaltwippen**.



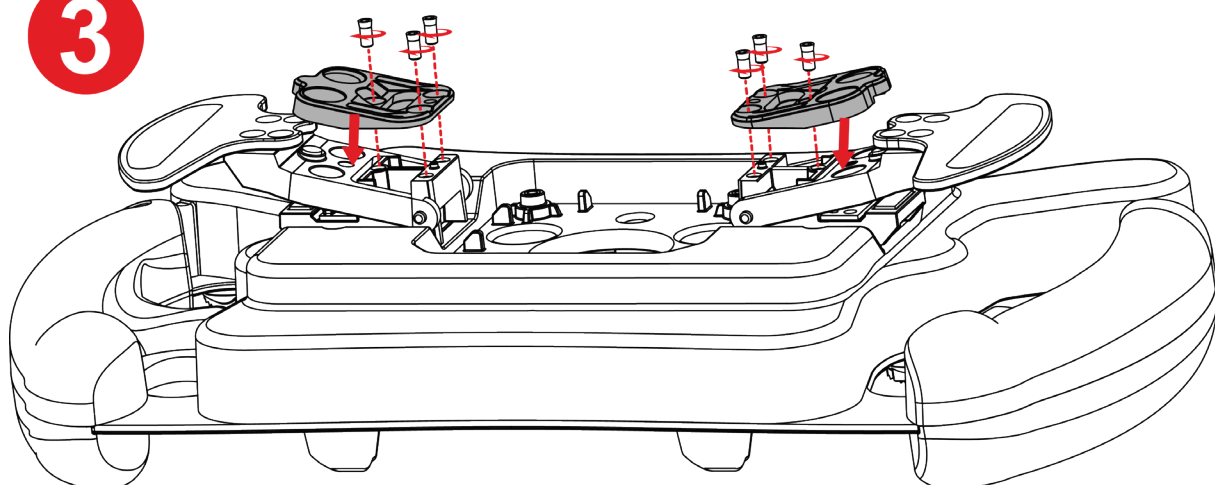

3

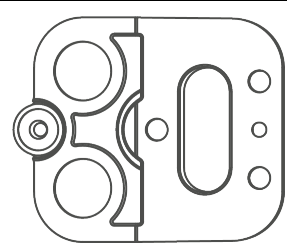
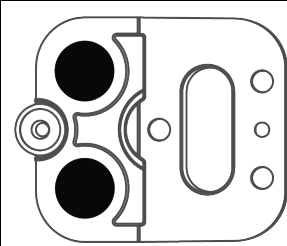
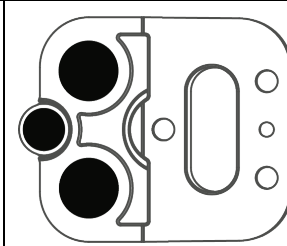

3 Bringen Sie die Magnet-Anschläge wieder an und ziehen Sie die sechs Anschlagschrauben mit dem mitgelieferten Torx-Schlüssel wieder fest.

Tabelle Magnetische Sensitivität und Geräuschdämpfung der Schaltwippen

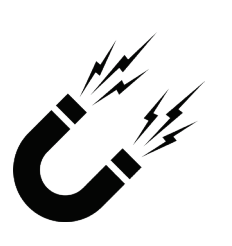
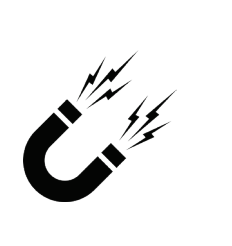
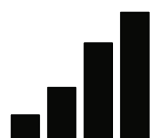
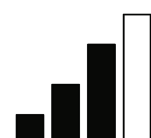
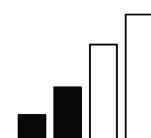
	 (Standard)		
Magnetische Sensitivität			
Geräusch			



8. FAQ und technischer Support

Haben Sie Fragen zum Ferrari 488 GT3 Wheel Add-On oder treten technische Probleme auf? Dann besuchen Sie bitte die Website des technischen Supports von Thrustmaster:

<https://support.thrustmaster.com/product/ferrarif488gt3addon>.

Auf dieser Seite finden Sie auch die Möglichkeit zur Aktualisierung der Firmware des Lenkrads.



THRUSTMASTER®

FERRARI 488 GT3 WHEEL ADD-ON

PC (Windows 10/11)

PS4™ / PS5™

Xbox Series / Xbox One

Gebruikershandleiding



Lees de instructies in deze handleiding zorgvuldig door **voordat** u het product installeert, **gebruikt** en **onderhoudt**. Zorg ervoor dat u de veiligheidsinstructies volgt. Het niet opvolgen van deze instructies kan leiden tot ongelukken en/of schade. Bewaar deze handleiding zodat u de instructies in de toekomst kunt raadplegen.

INHOUDSTAFEL

1.	DOOS INHOUD.....	5
2.	KENMERKEN	6
3.	INFORMATIE OVER HET GEBRUIK VAN HET WIEL	8
4.	INSTALLATIE VAN DE SNELSPANHOUDER.....	13
	<i>Installatie van de snelspanhouder voor de klinkbevestiging</i>	<i>14</i>
	<i>Installatie van de snelspanhouder voor de schroefbevestiging</i>	<i>17</i>
5.	MAPPING.....	21
	<i>Mapping voor PC.....</i>	<i>21</i>
	<i>Mapping voor PS4™/PS5™</i>	<i>22</i>
	<i>Mapping voor Xbox Series/Xbox One</i>	<i>23</i>
6.	LED-WERKING.....	24
	<i>Hoe het led-menu openen/sluiten.....</i>	<i>25</i>

***Hoe moet ik de intensiteit van de leds
aanpassen.....27***

***Hoe kan ik de led-modus wijzigen: GT3 of
Formula28***

7. AANPASSING VAN DE PADDLE

SHIFTERS29

***Hoe kan ik de afstand tussen paddle
shifters aanpassen.....31***

***Hoe kan ik het bereik tussen paddle
shifters aanpassen.....33***

***Hoe kan ik de magnetische gevoeligheid
en het geluidsniveau van de paddle
shifters aanpassen.....35***

8. FAQ EN TECHNISCHE

ONDERSTEUNING.....37



FERRARI 488 GT3 WHEEL ADD-ON

Maak deel uit van de legende van de het GT-racen met het Ferrari 488 GT3 Wheel Add-On, een stuur dat is ontworpen voor topprestaties en compatibel is met alle stuurbasissen van Thrustmaster.

Deze handleiding helpt u bij het installeren en gebruiken van uw Ferrari 488 GT3 Wheel Add-On onder de beste omstandigheden. Lees voordat u begint met racen de instructies en waarschuwingen aandachtig door: ze zullen u helpen het meeste plezier uit uw product te halen.



1. Doos inhoud

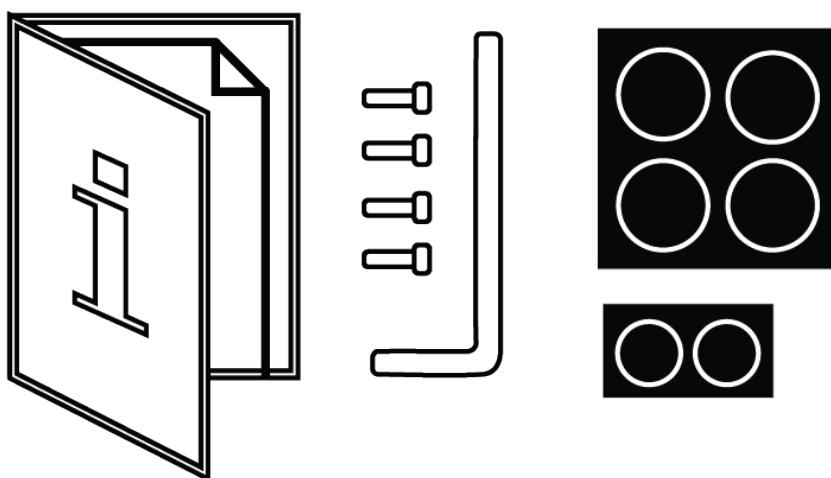
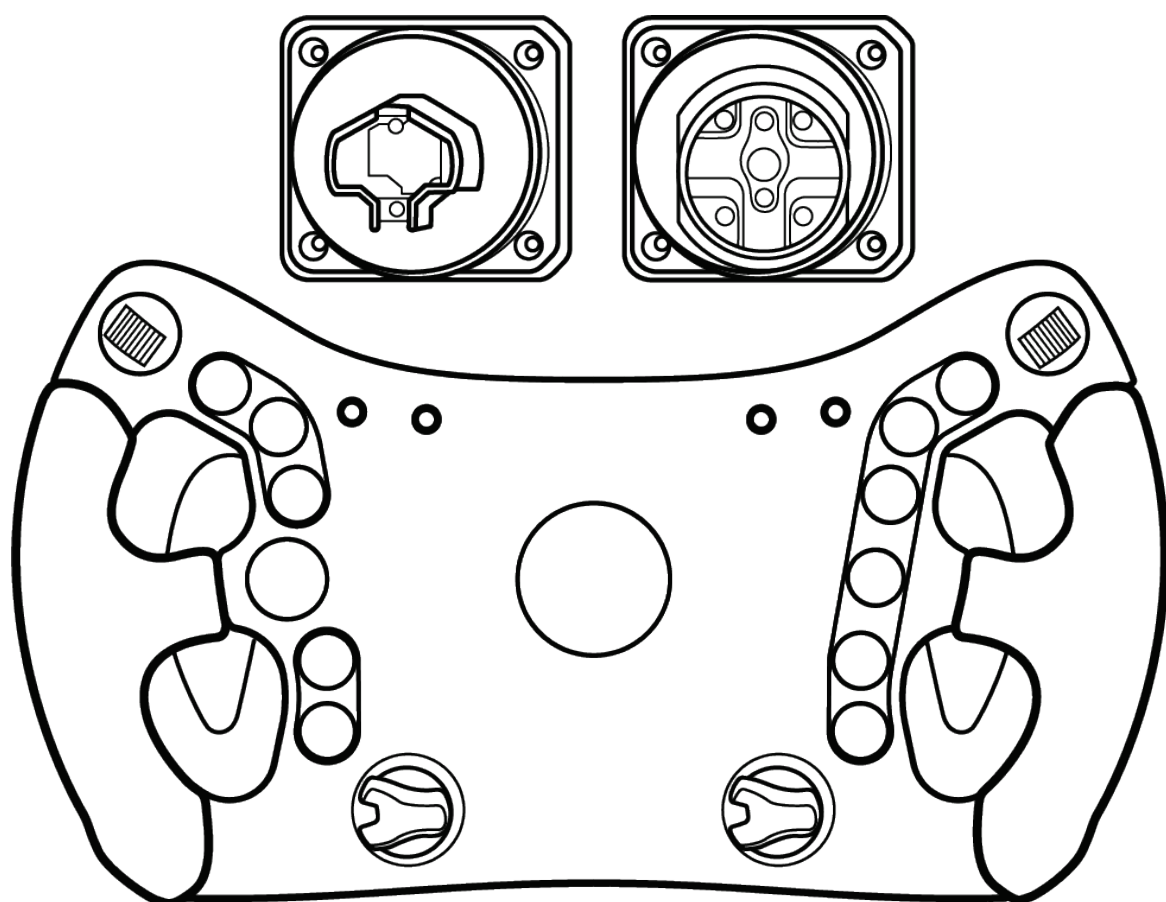



2. Kenmerken

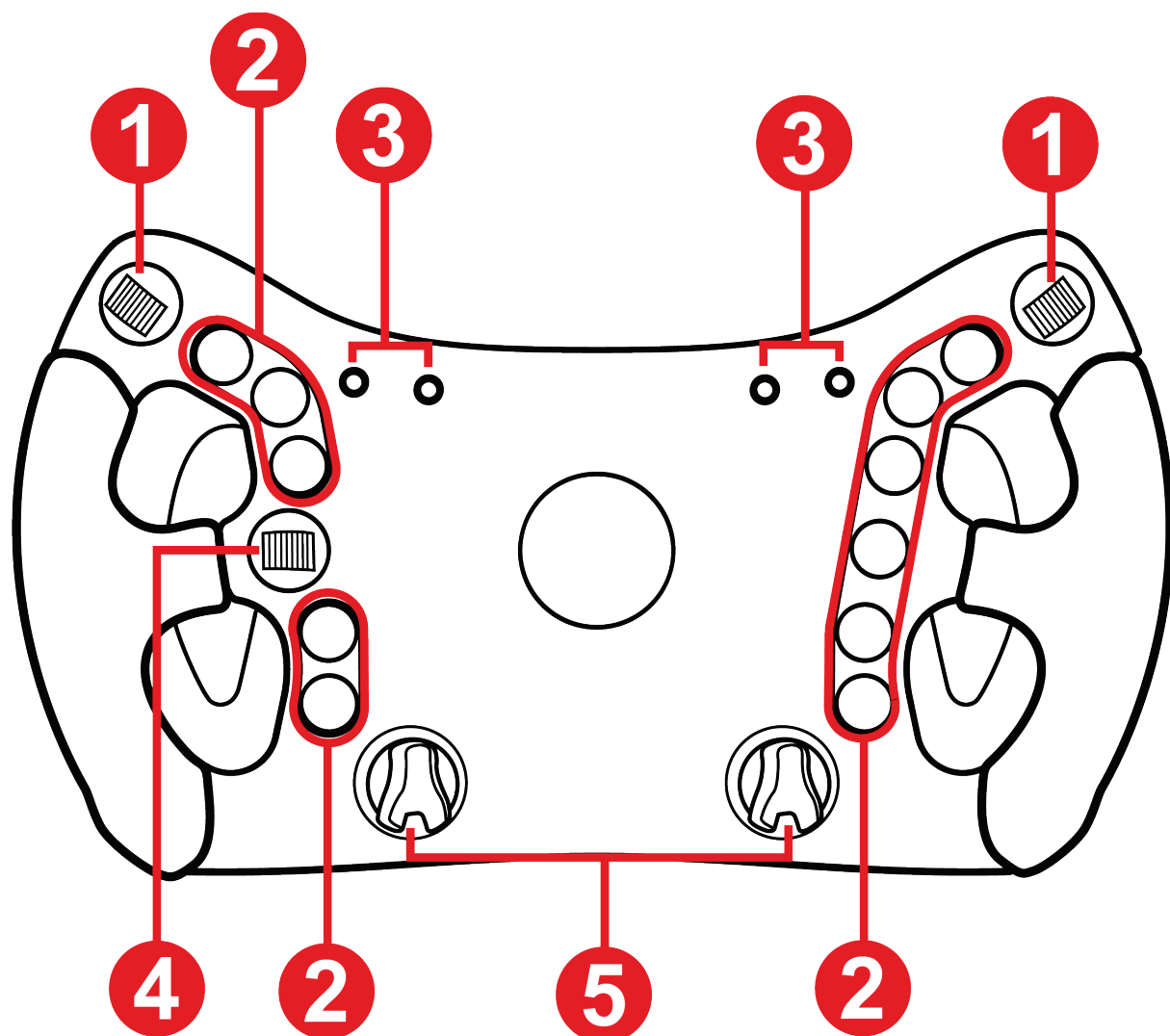

- ❶ Duim-encoders
- ❷ 11 actieknoppen
- ❸ RPM-LED's en racegegevens (vlaggen, pits)
- ❹ D-pad
- ❺ Roterende encoders

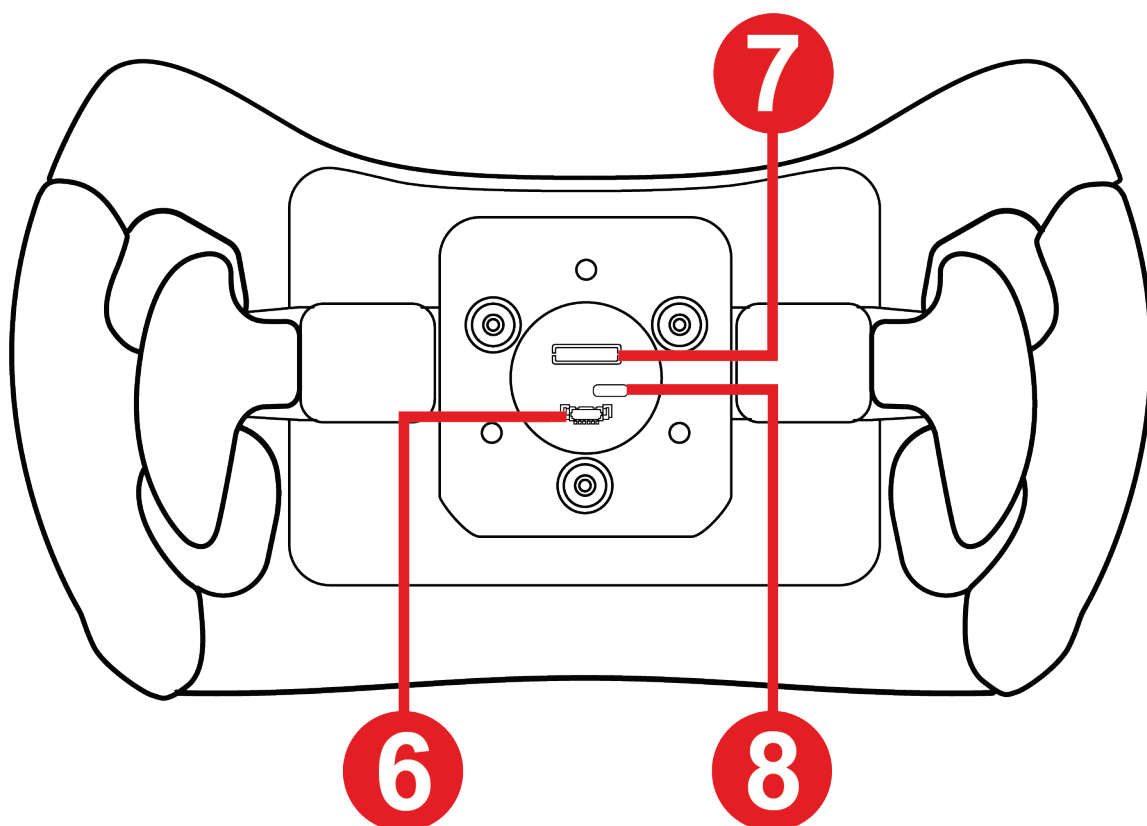

⑥ Aansluitpoort voor snelspanhouder voor schroefbevestiging

⑦ Aansluitpoort voor snelspanhouder voor klinkbevestiging

⑧ USB-C-poort (als een firmware-update vereist is - kabel niet meegeleverd)

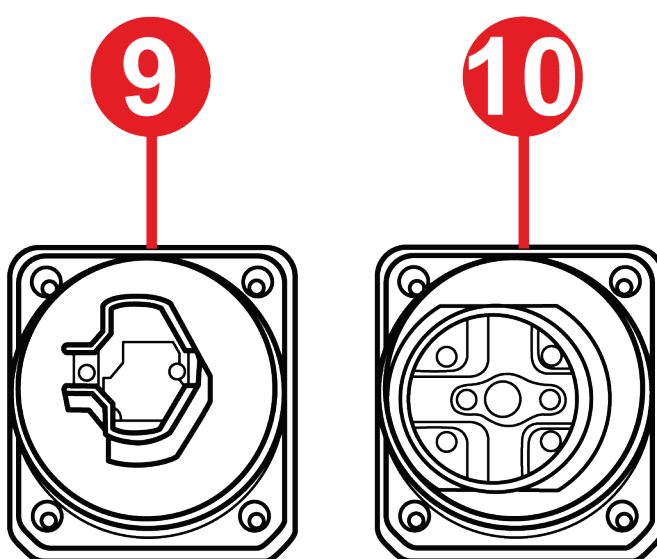

⑨ Snelspanhouder voor klinkbevestiging

⑩ Snelspanhouder voor schroefbevestiging



3. Informatie over het gebruik van het wiel



Documentatie

Lees deze documentatie zorgvuldig door voordat u het product gebruikt, en bewaar deze voor toekomstig gebruik.



Elektrische schok

- Bewaar het product op een droge plaats en stel het niet bloot aan stof of zonlicht.
- Verdraai of trek niet aan de connectors en kabels.
- Volg de aansluitingsinstructies.
- Mors geen vloeistof op het product of de aansluitingen.
- Kortsluit het product niet.
- Demonteer het product nooit (behalve in de gevallen van aanpassingen die in deze handleiding worden vermeld); gooi het niet in het vuur en stel het niet bloot aan hoge temperaturen.
- Open het apparaat niet: er bevinden zich onderdelen binnenin die niet gebruiksvriendelijk zijn. Reparaties moeten worden uitgevoerd door de fabrikant, een gespecificeerd bureau of een gekwalificeerde technicus.



De speelzone beveiligen

- Plaats geen voorwerpen in de speelruimte die de oefening van de gebruiker kunnen verstoren, of die een ongepaste beweging of een onderbreking door een andere persoon kunnen uitlokken (koffiekopje, telefoon, sleutels, bijvoorbeeld).
- Bedek de stroomkabels niet met een tapijt, deken, bedekking of iets dergelijks en leg geen kabels op plaatsen waar mensen lopen.



Schade door Force Feedback en herhaalde bewegingen

Het gebruik van een Force Feedback-racestuur kan spier- of gewrichtspijn veroorzaken. Om problemen te vermijden:

- Doe van tevoren een opwarmingsoefening en vermijd lange oefenperioden.
- Neem 10 à 15 minuten pauze na elk uur spelen.
- Als u vermoeidheid of pijn voelt in uw handen, polsen, armen, voeten of benen, druk dan op de knop om Force Feedback uit te schakelen, schakel de basis uit en rust een paar uur voordat u weer gaat oefenen.
- Als de hierboven aangegeven symptomen of pijnen aanhouden wanneer u weer begint te oefenen, stop dan met oefenen en raadpleeg uw arts.
- Stel de Force Feedback niet in op een niveau dat te hoog is in verhouding tot uw deskundigheid en lichamelijke conditie.
- Houd het apparaat buiten het bereik van personen jonger dan 16 jaar.
- Zorg ervoor dat de basis en het wiel goed bevestigd zijn, volgens de instructies in de handleiding.



Risico op onvoorziene, krachtige en snelle rotaties: steek nooit een hand of arm door de openingen in de velg of in de rotatiebaan van het wiel.

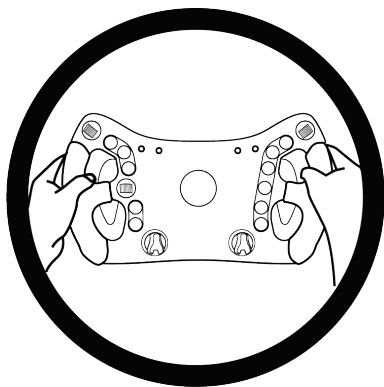

Laat tijdens het gebruik van het product altijd beide handen correct op het stuur liggen, zonder het ooit helemaal los te laten.



Het product mag alleen worden gebruikt door personen van **16 jaar of ouder**.



4. Installatie van de snelspanhouder

Ferrari 488 GT3 Wheel Add-On wordt geleverd met twee snelspanhouders die overeenstemmen met de formaten van Thrustmaster-basissen.

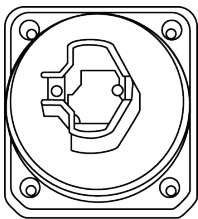
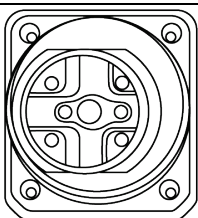
Systemem	Compatibiliteit
 Snelspanhouder voor klinkbevestiging	T818, T818 Ferrari SF1000 Simulator en toekomstige Thrustmaster basissen.
 Snelspanhouder voor schroefbevestiging	T-GT / T-GT II Servo Base, T300 RS Servo Base, TS PC Racer, TS-XW, TX Racing Wheel Servo Base, TS-XW Servo Base.



Controleer voor elk gebruik of de **Ferrari 488 GT3 Wheel Add-On** nog goed is bevestigd aan de steun, volgens de instructies in de handleiding voor de basis.



Installatie van de snelspanhouder voor de klinkbevestiging

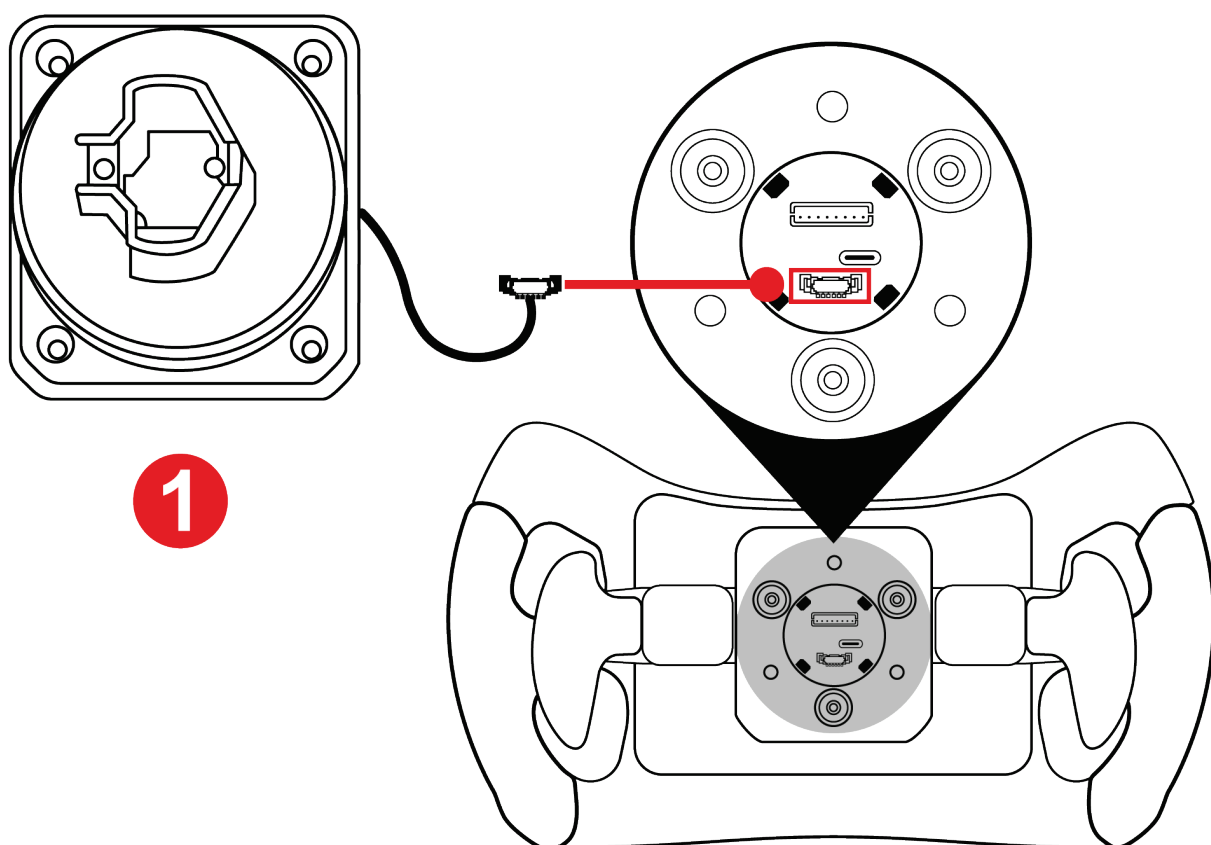

1

1 Steek de connector van de snelspanhouder in de overeenkomstige poort aan de achterkant van het stuur.



Om te voorkomen dat de kabel bekneld raakt, trekt u deze terug in de behuizing voordat u de houder vastschroeft.

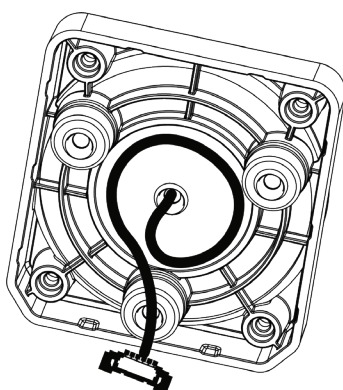

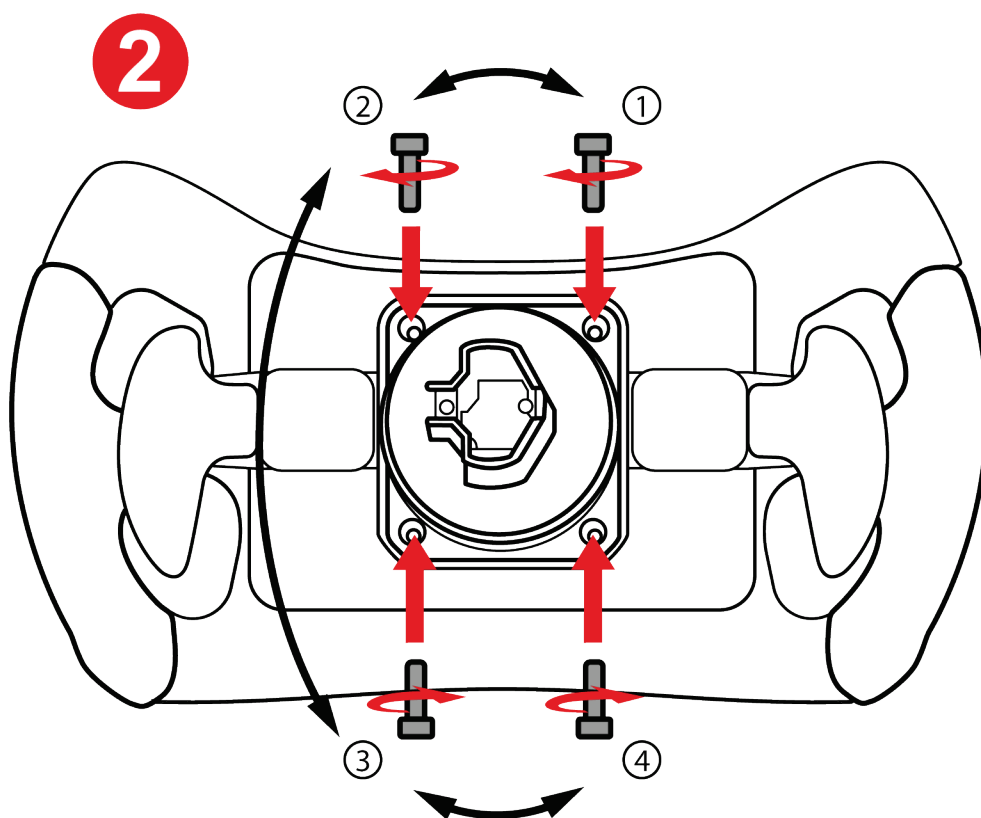

2 Plaats de snelspanhouder en draai deze vast met de meegeleverde Torx-sleutel.



Draai de schroeven niet te vast aan bij het monteren van de houder.

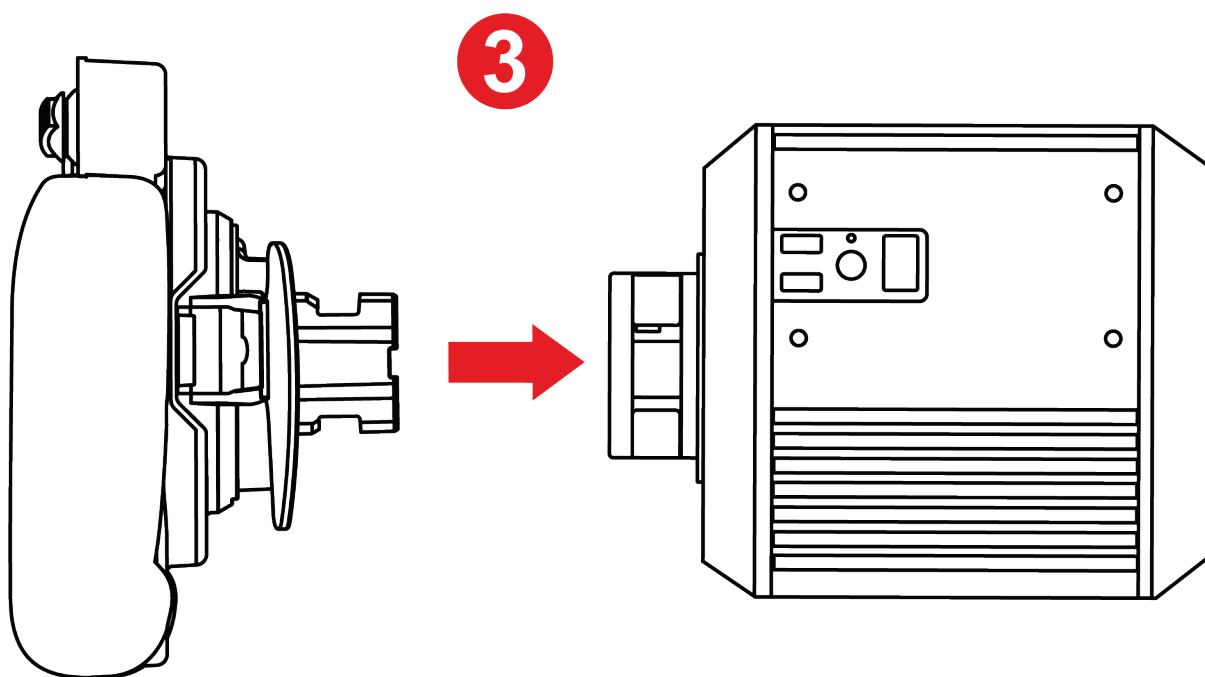

3 Monteer het stuur op de basis.



Volg de installatieprocedure die in de handleiding van de basis vermeld staat.



Installatie van de snelspanhouder voor de schroefbevestiging

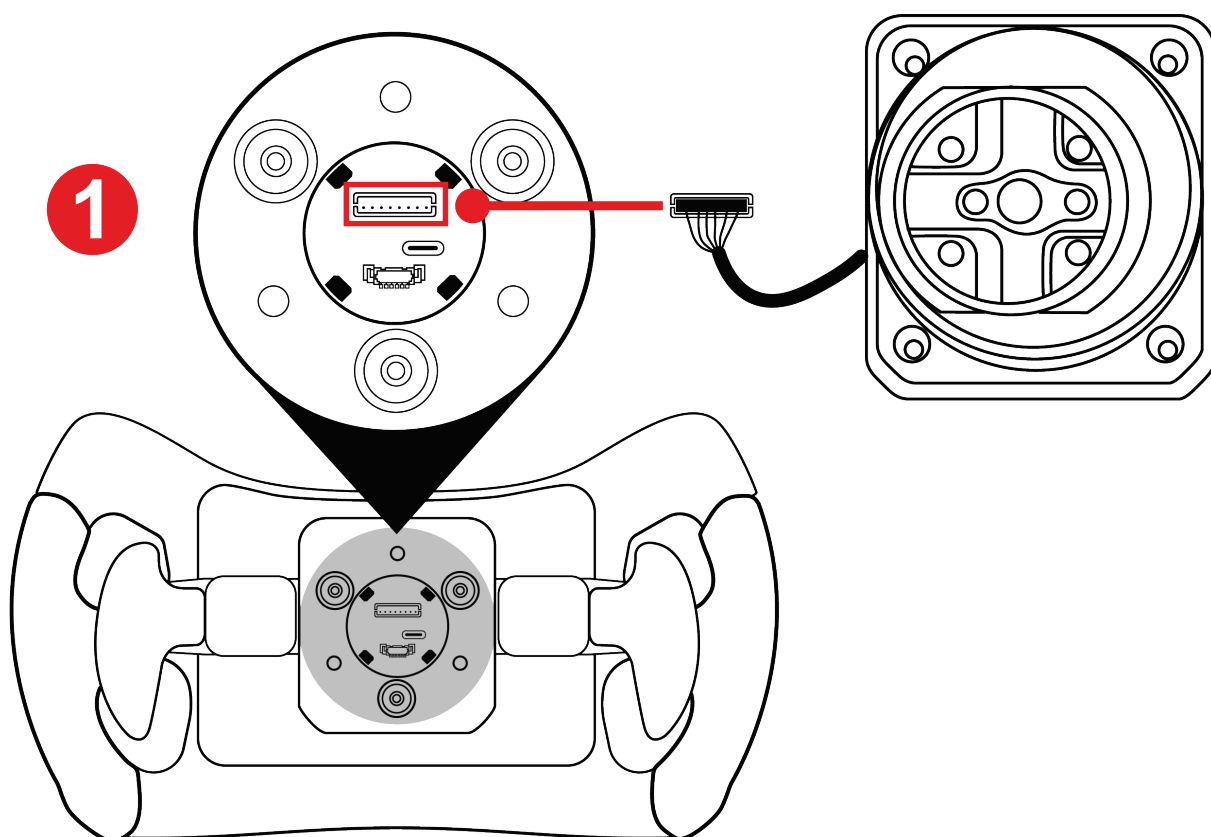

1 Steek de connector van de snelspanhouder in de overeenkomstige poort aan de achterkant van het stuur.



Om te voorkomen dat de kabel bekneld raakt, trekt u deze terug in de behuizing voordat u de houder vastschroeft.

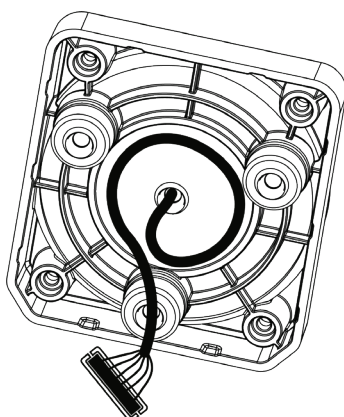

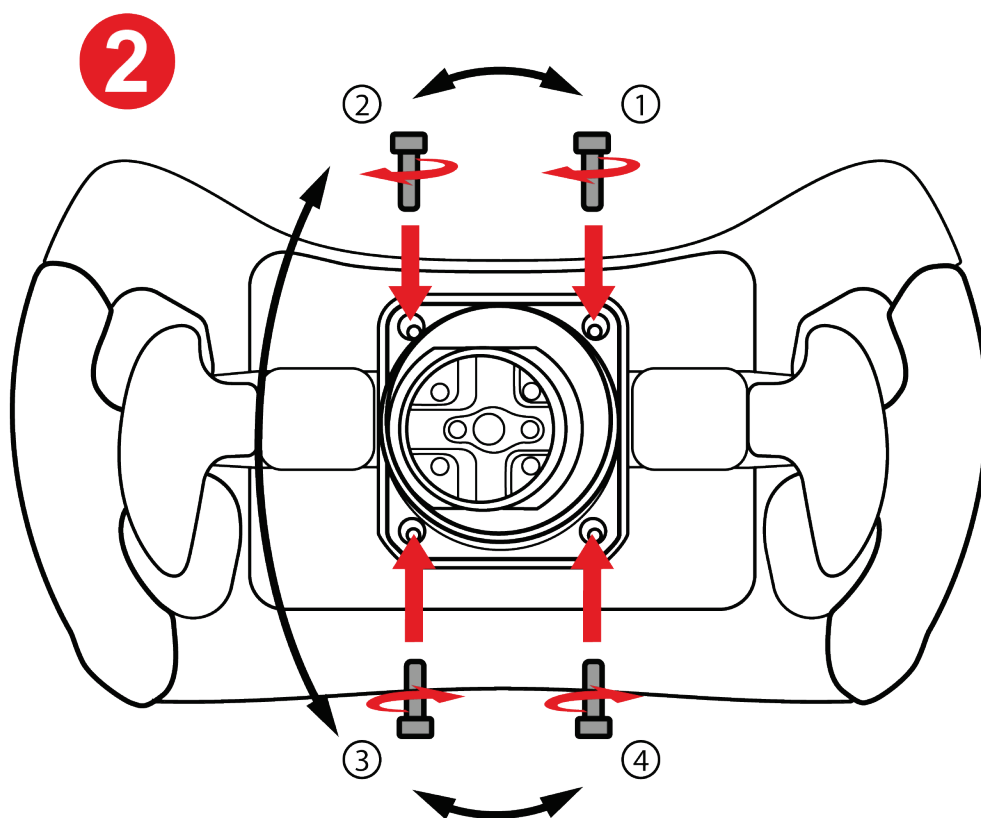

2 Plaats de snelspanhouder en draai deze vast met de meegeleverde Torx-sleutel.



Draai de schroeven niet te vast aan bij het monteren van de houder.

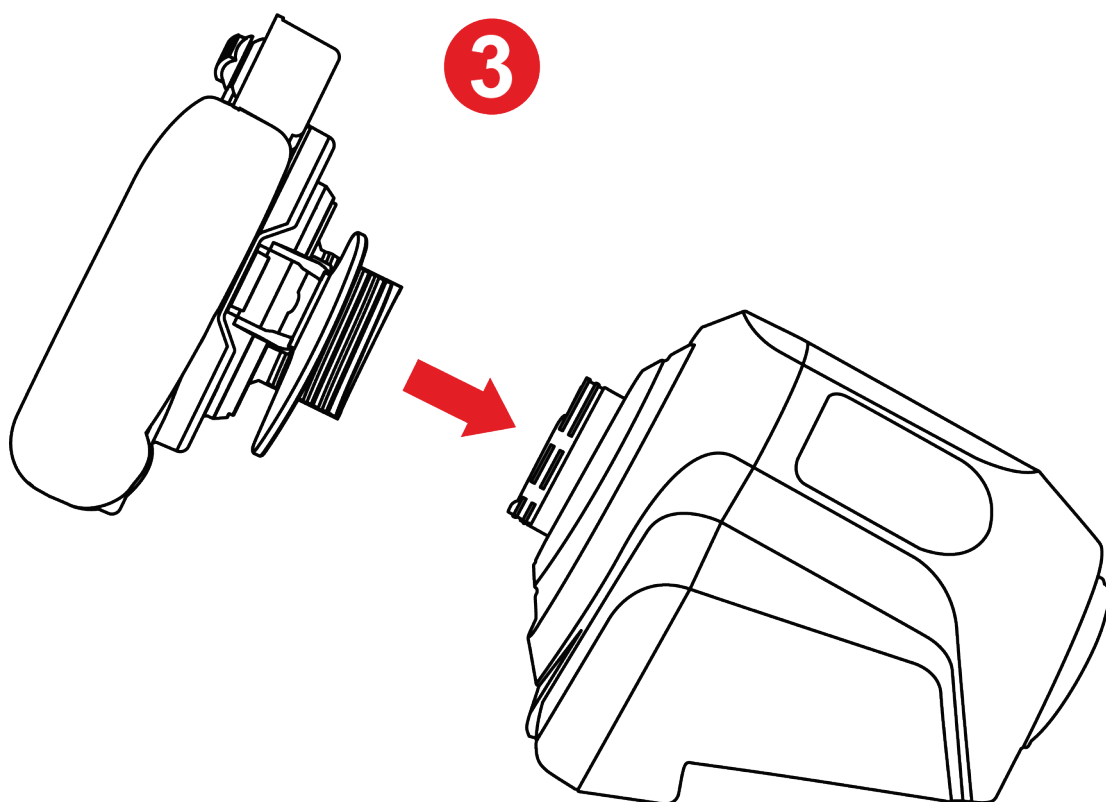

3 Monteer het stuur op de basis.



Volg de installatieprocedure die in de handleiding van de basis vermeld staat.



Sluit de snelspanadapter (bijgeleverd bij de T818 basis en apart verkrijgbaar) nooit aan op de snelspanhouder voor schroefbevestiging als u deze op een T818 basis wilt gebruiken.

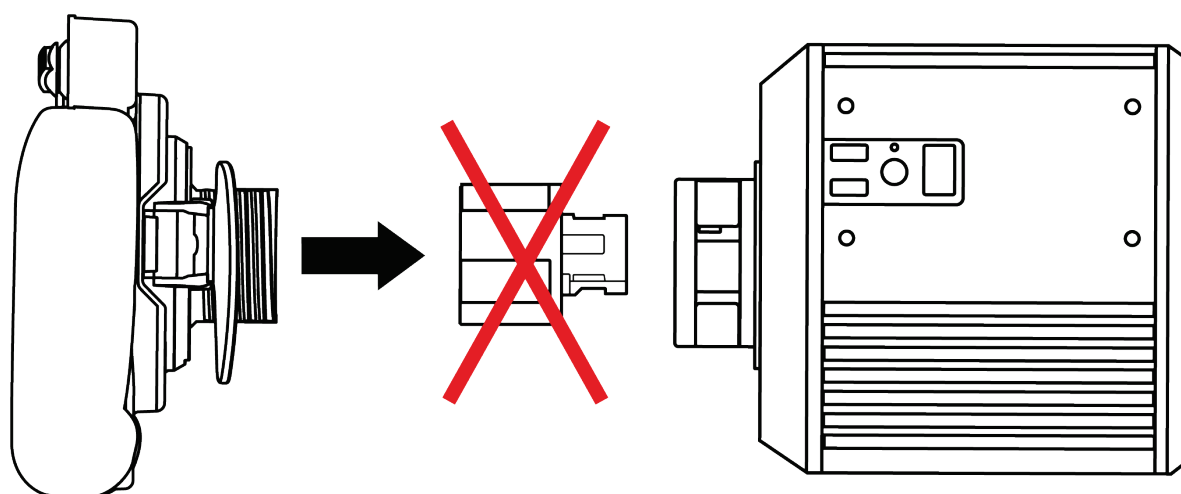
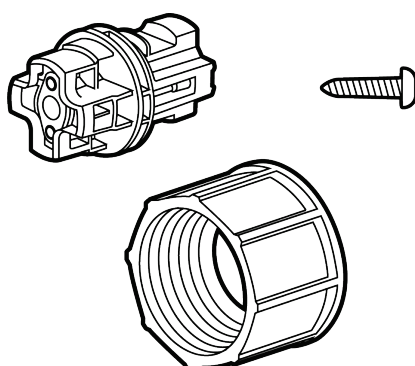

Voor gebruik op een T818 basis of een basis die is uitgerust met een connector voor klinkbevestiging, gebruikt u alleen de **snelspanhouder voor klinkbevestiging** die wordt meegeleverd met de **Ferrari 488 GT3 Wheel Add-On**.



5. Mapping

Mapping voor PC

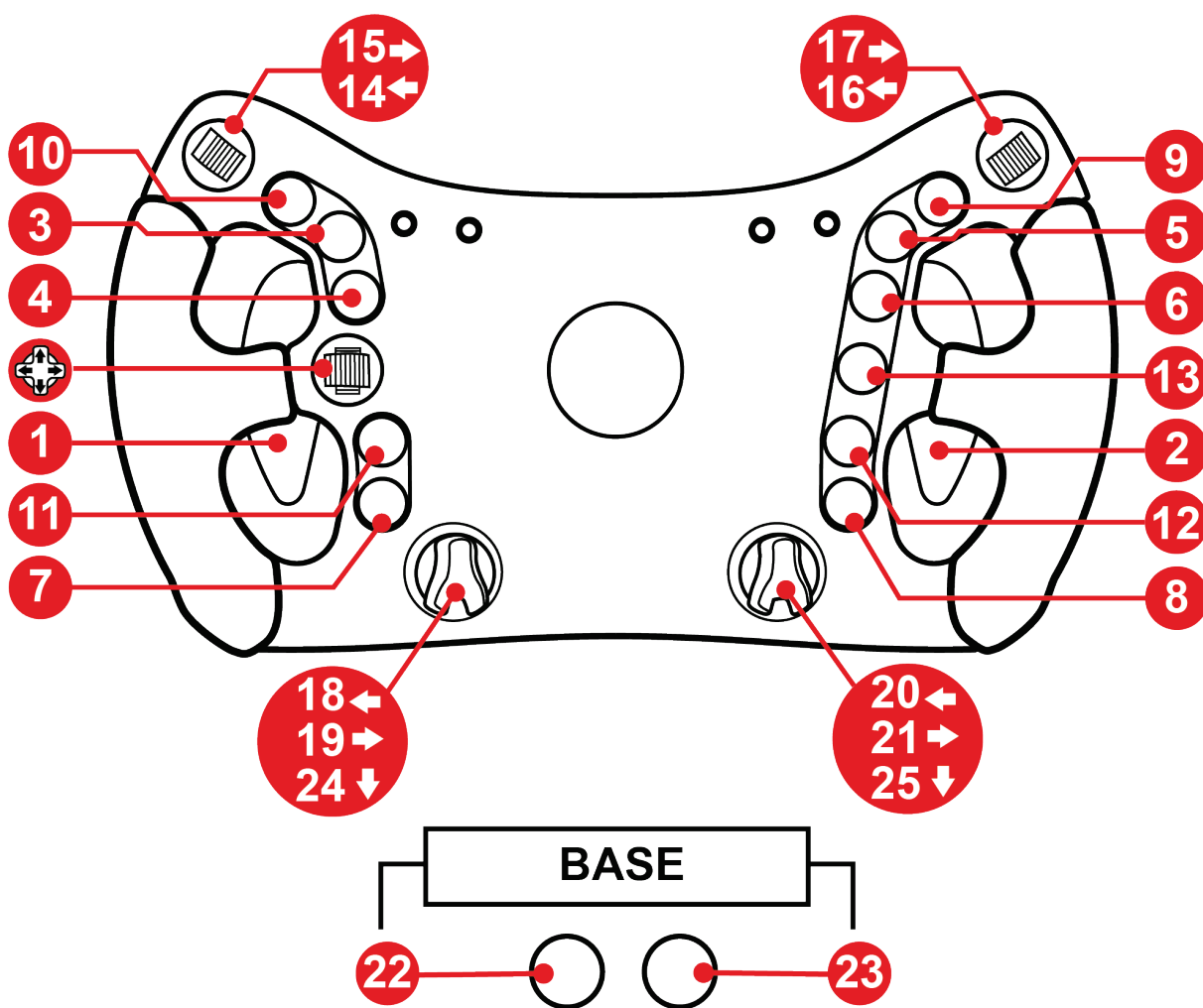



Mapping voor PS4™/PS5™

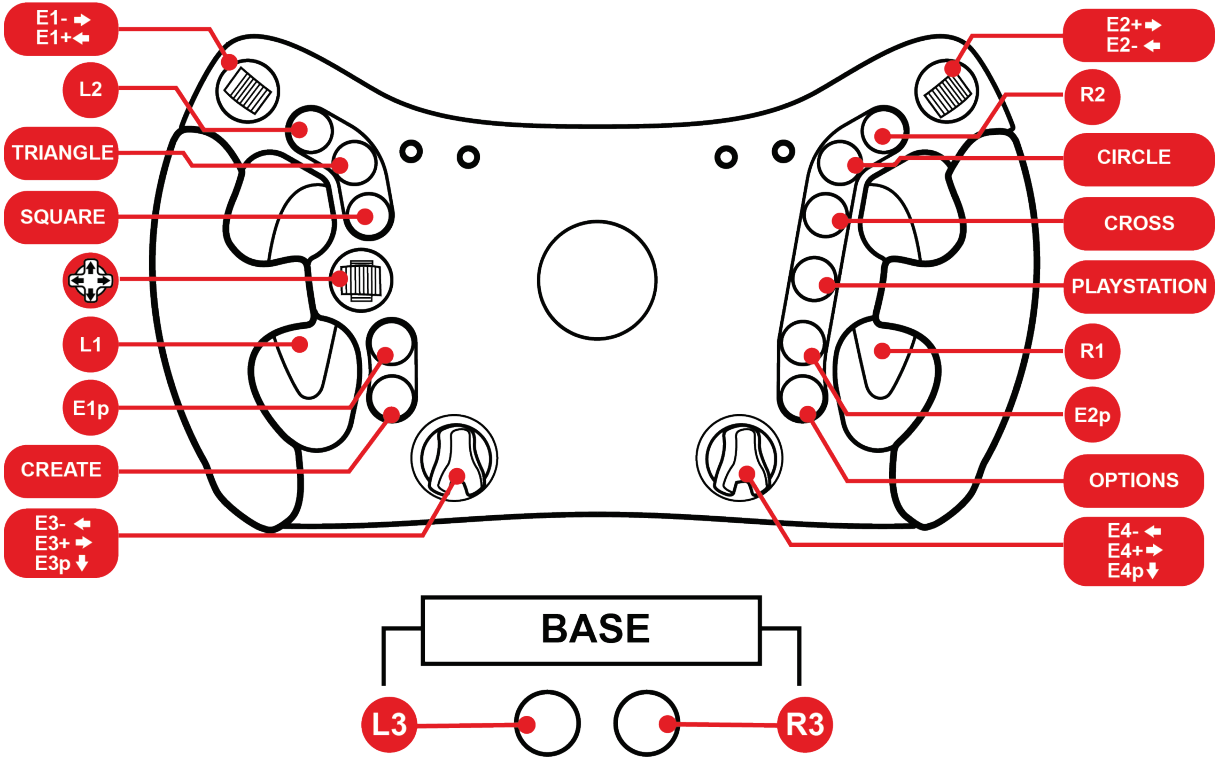



Mapping voor Xbox Series/Xbox One

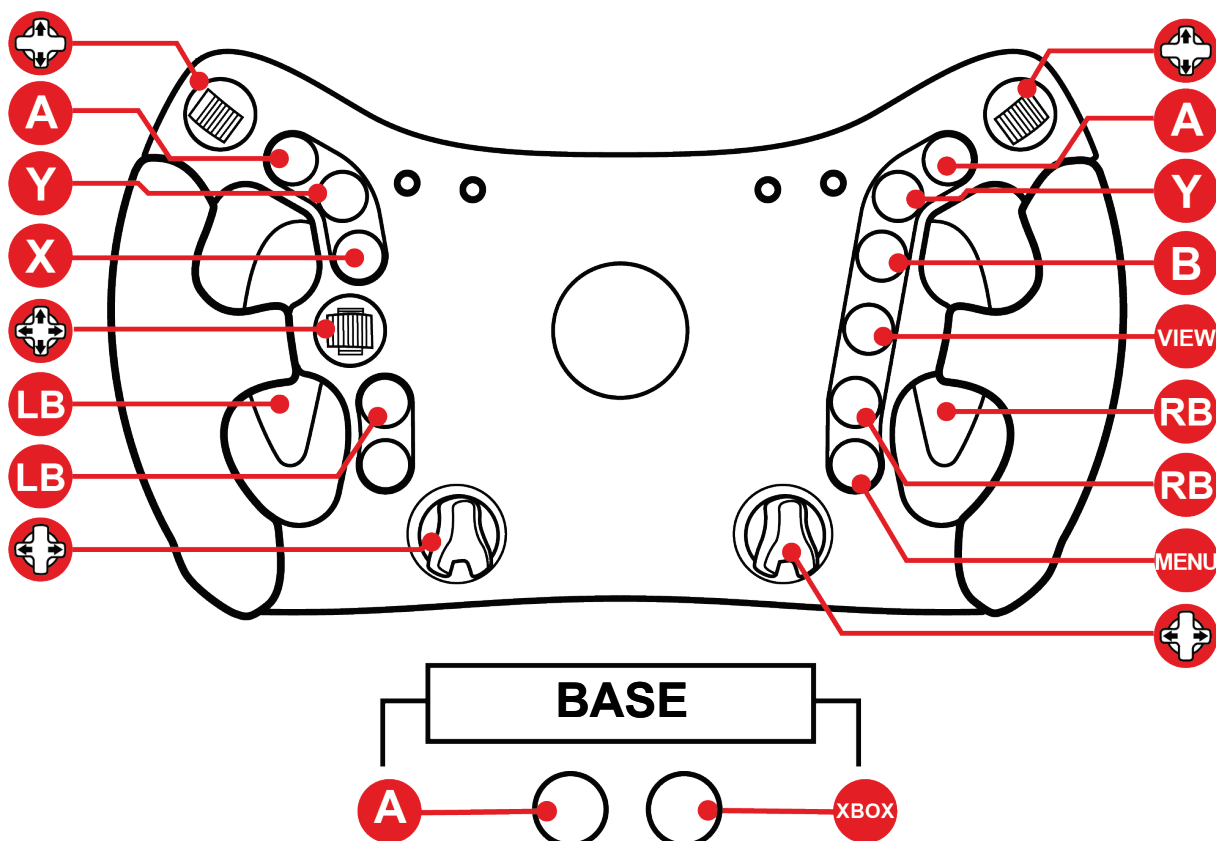

Op Xbox Series en Xbox One:

- De leds op de Ferrari 488 GT3 Wheel Add-On werken niet door beperkingen van het consoleprotocol.
- Sommige functies (encoders, aantal knoppen) worden beperkt door het consoleprotocol.



6. Led-werking

Ferrari 488 GT3 Wheel Add-On geeft racegegevens weer via de ledlampen: vlag, pit en toerental.

De weergegeven gegevens kunnen worden aangepast (intensiteit en kleur van de RPM-leds), afhankelijk van de modus (GT3 of Formula).

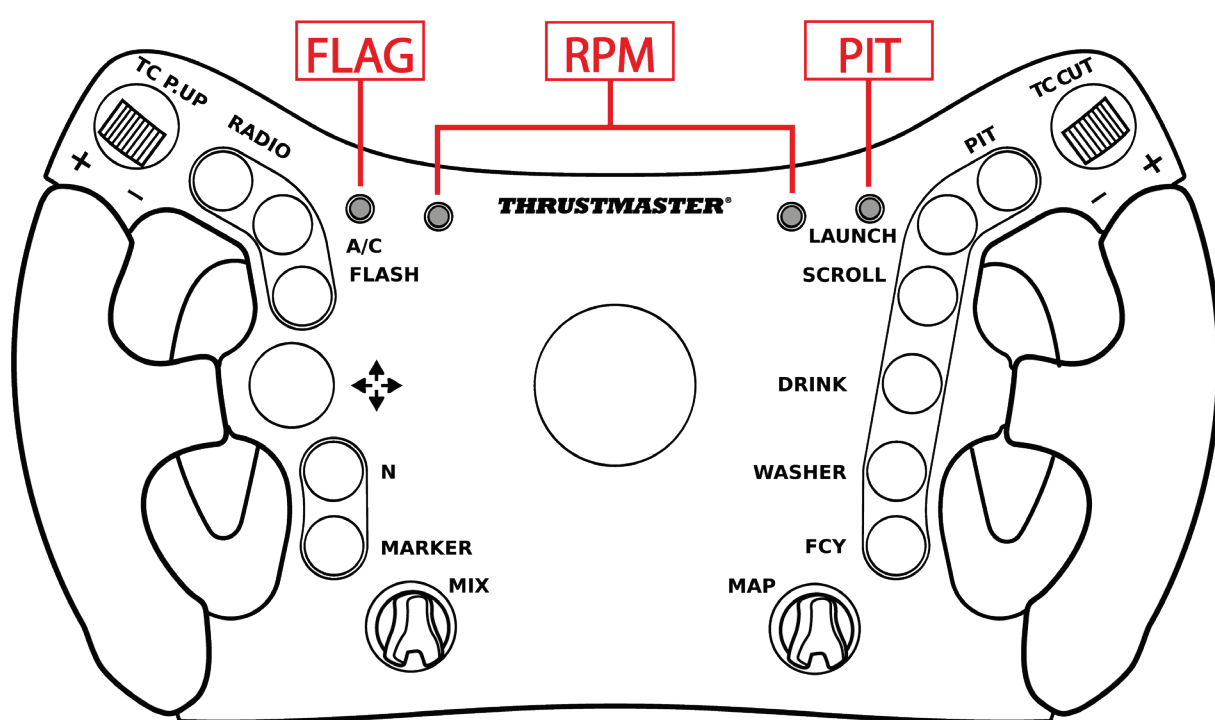

De leds werken op PC en PS4™/PS5™.

Op de Xbox Series en Xbox One zijn de leds niet functioneel vanwege protocolbeperkingen van de console.



Hoe het led-menu openen/sluiten

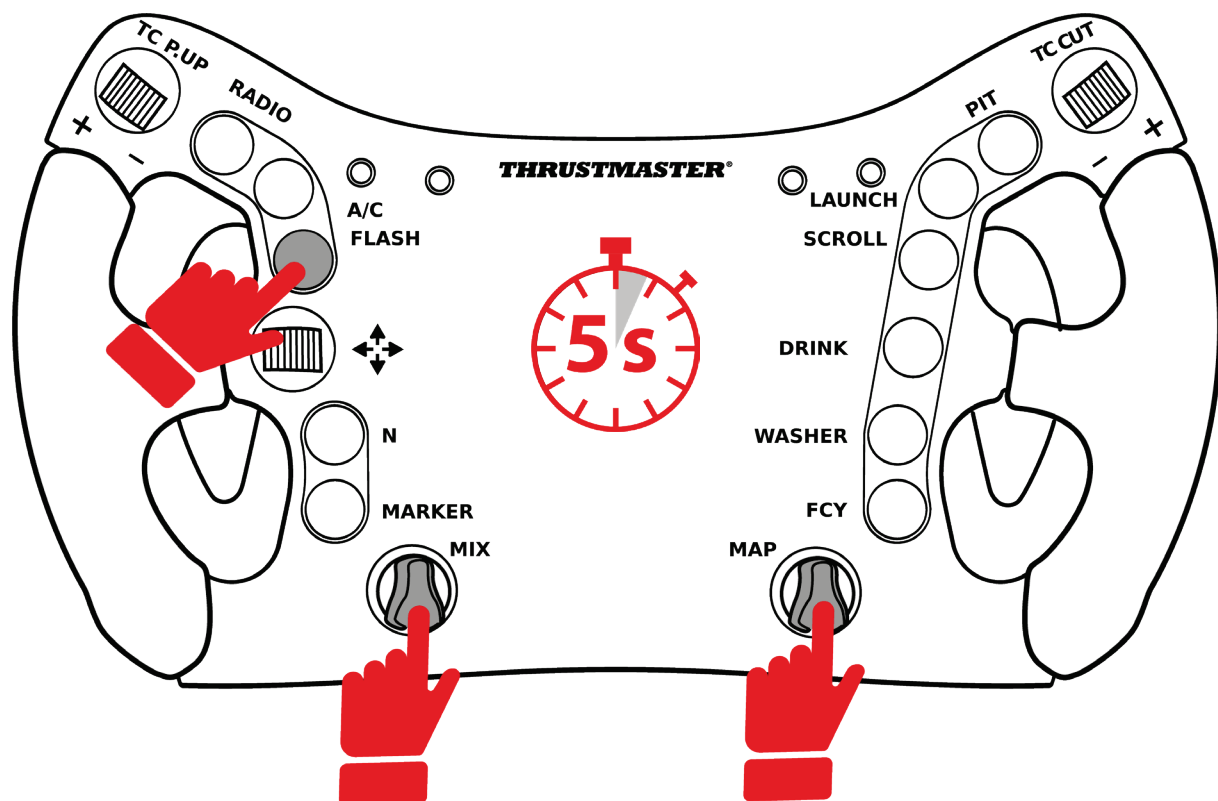

- Om het led-menu te openen, drukt u tegelijkertijd op de **FLASH**-knop en beide **roterende encoders** gedurende **5 seconden**, en laat u ze daarna los.

- Om het led-menu te sluiten, drukt u tegelijkertijd op de **FLASH**-knop en beide **roterende encoders**, en laat u ze daarna los.



FLAG

RPM

PIT

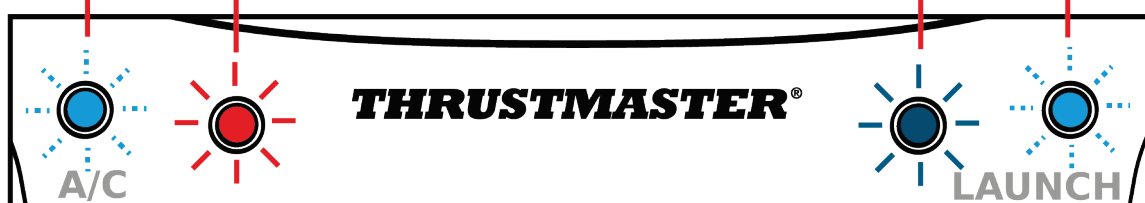

Ga naar het led-menu: de FLAG en PIT leds en een van de RPM leds (links rood of rechts blauw) gaan branden.



Sluit het led-menu af: alle vier de leds gaan uit.



Hoe moet ik de intensiteit van de leds aanpassen

- Open het led-menu door tegelijkertijd te drukken op de **FLASH**-knop en op beide **roterende encoders** gedurende **5 seconden**, en laat ze daarna los.
- Draai de **linker encoder (MIX)** naar links om de intensiteit te verlagen, of naar rechts om de intensiteit te verhogen.



- Sluit het led-menu door tegelijkertijd te drukken op de **FLASH**-knop en op beide **roterende encoders**, en laat ze daarna los.



Hoe kan ik de led-modus wijzigen: GT3 of Formula

- Open het led-menu door tegelijkertijd te drukken op de **FLASH**-knop en op beide **roterende encoders** gedurende **5 seconden**, en laat ze daarna los.
- Draai de **rechter encoder (MAP)** naar links om de GT3-modus (rode led) te selecteren, of naar rechts om de Formula-modus (blauwe led) te selecteren.



GT3-modus (standaard modus)



FORMULA-modus

- Sluit het led-menu door tegelijkertijd te drukken op de **FLASH**-knop en op beide **roterende encoders**, en laat ze daarna los.



7. Aanpassing van de paddle shifters

De paddle shifters van de **Ferrari 488 GT3 Wheel Add-On** zijn verstelbaar qua **afstand** en **bereik**.

De **creatie van afstand** bestaat uit het aanpassen van de breedte van de paddle shifter, waardoor de afstand tussen de handgreep en de paddle shifter verandert.

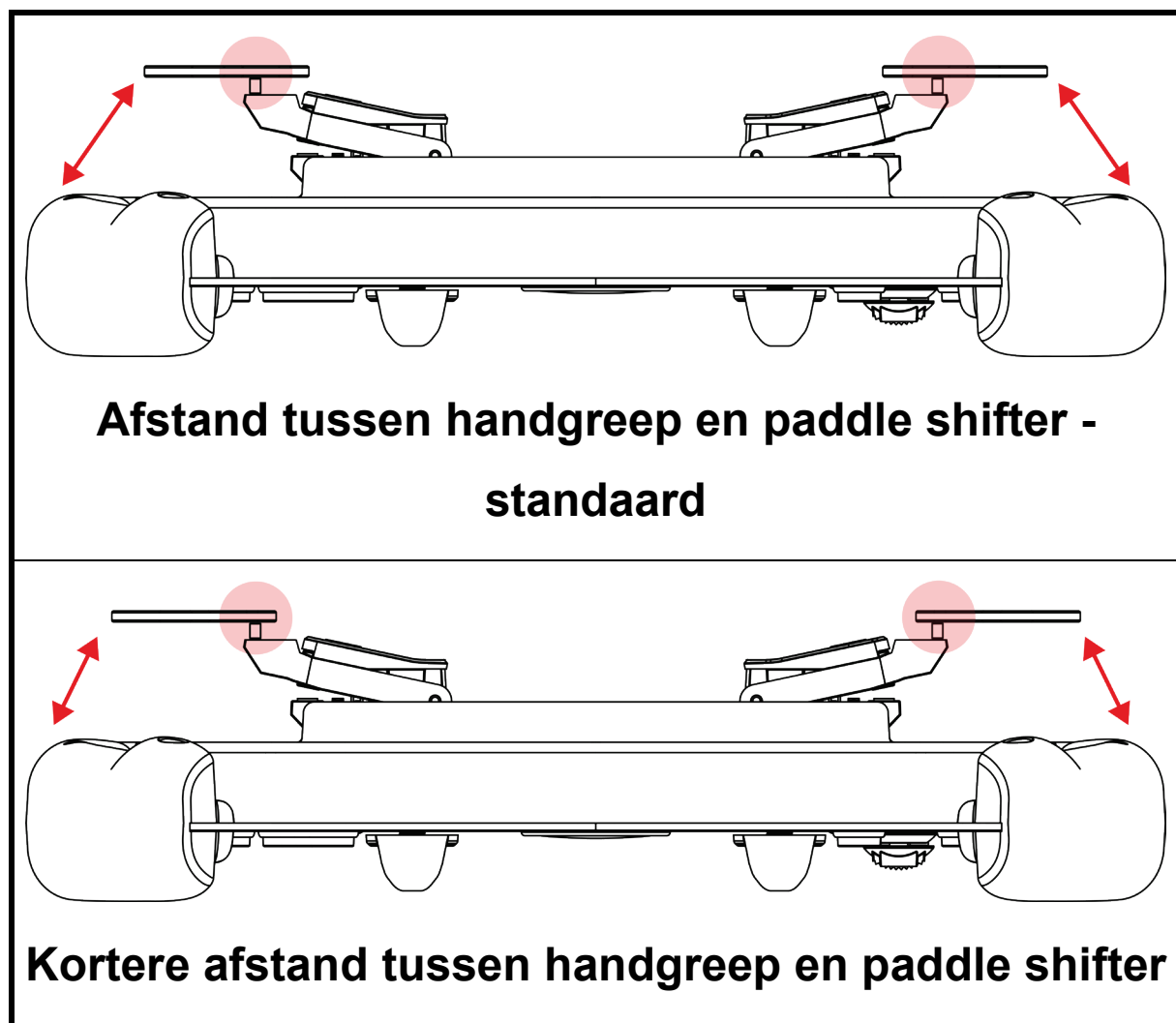



Door het **bereik** aan te passen met behulp van de afstandsstukken, verandert de activeringsafstand van de paddle shifter.

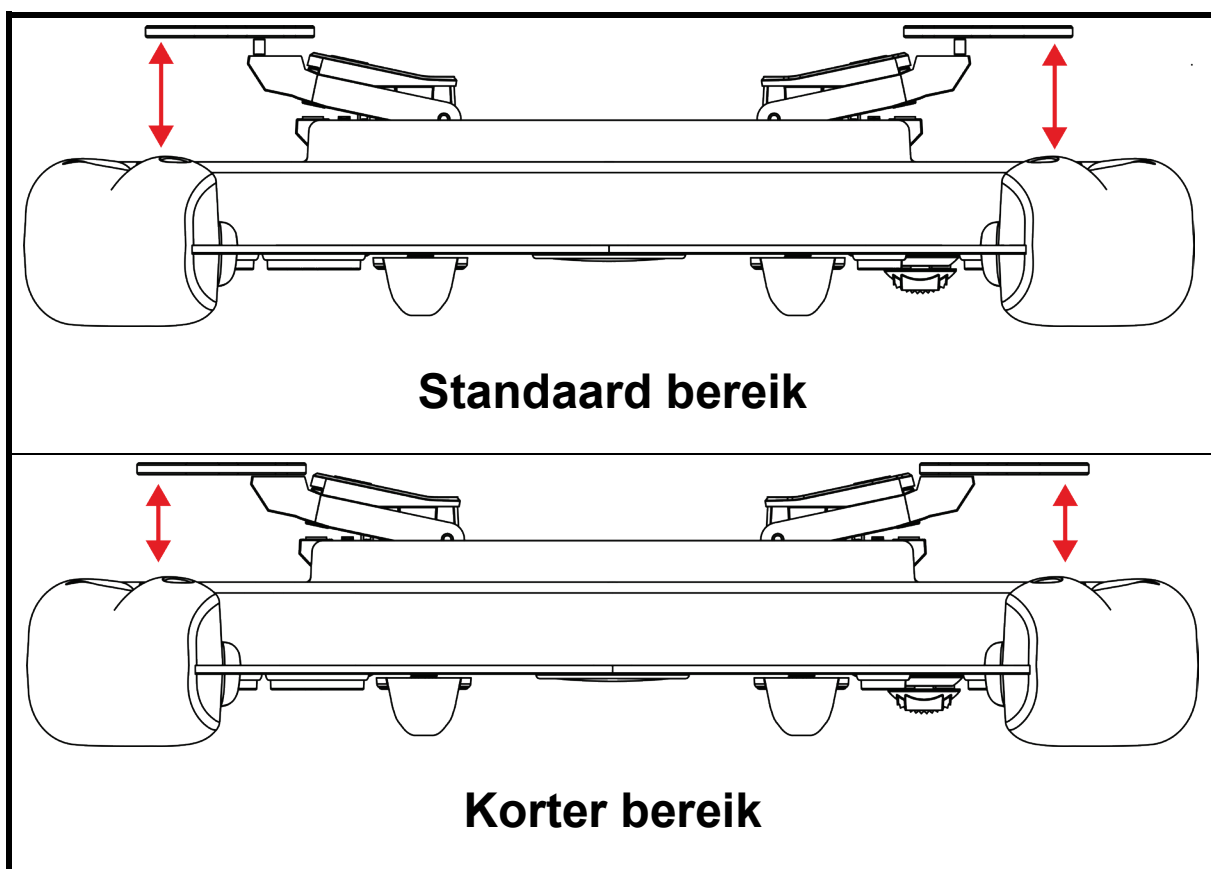

Het is ook mogelijk om de **magnetische gevoeligheid** en het **geluidsniveau** van de paddle shifters aan te passen met behulp van de meegeleverde set pads.

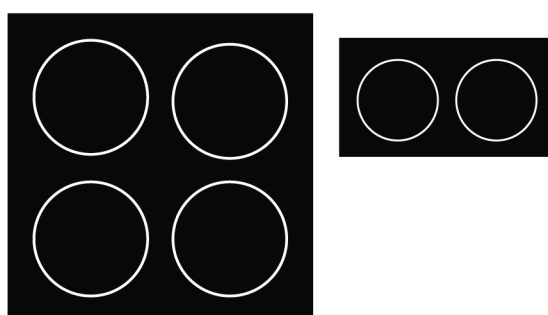



Hoe kan ik de afstand tussen paddle shifters aanpassen

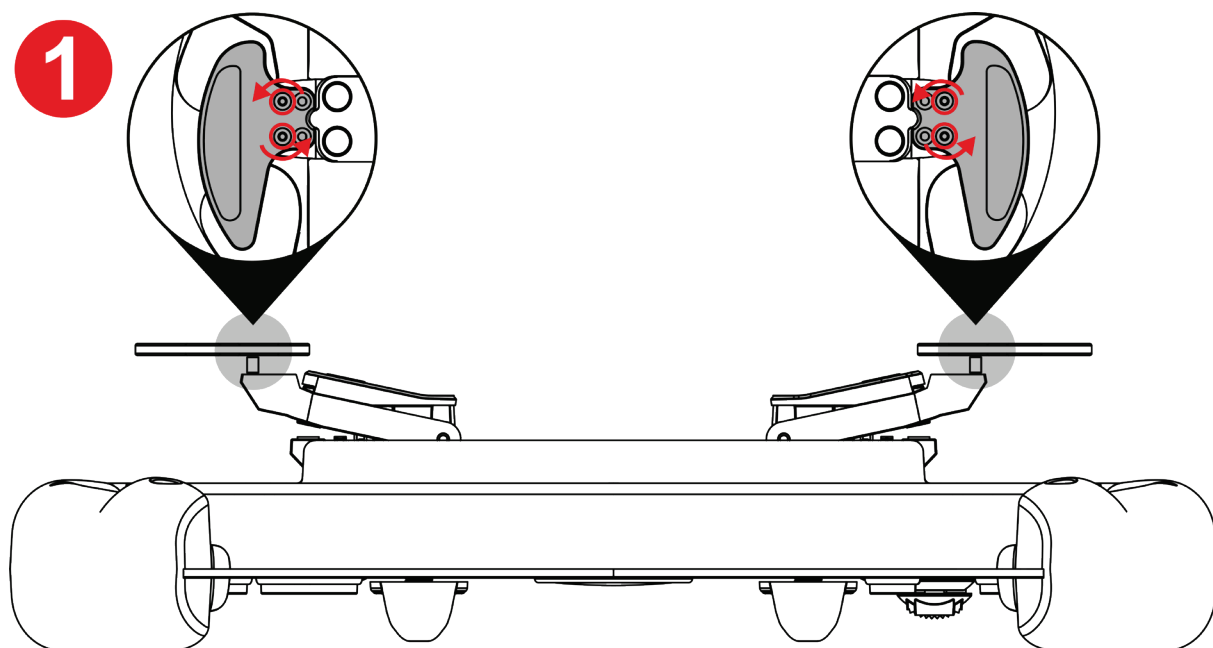

1 Draai de vier schroeven van de paddle shifter los met de bijgeleverde Torx-sleutel.

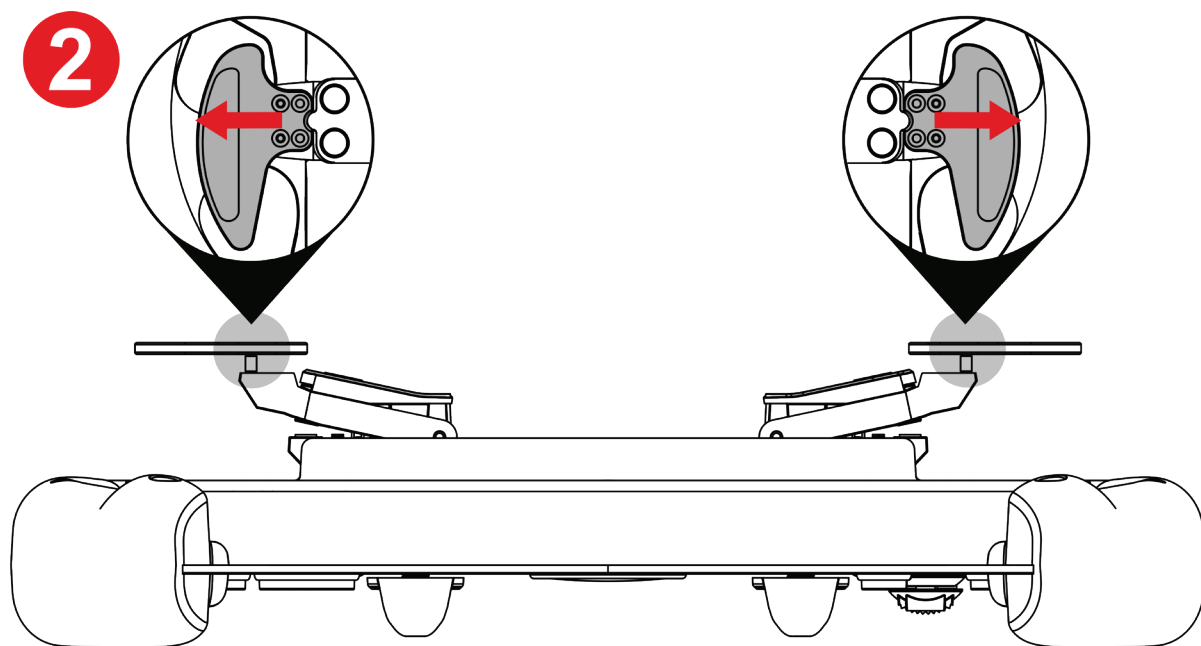

2 Schuif de paddle shifters naar buiten zodat ze overeenkomen met de gaten.

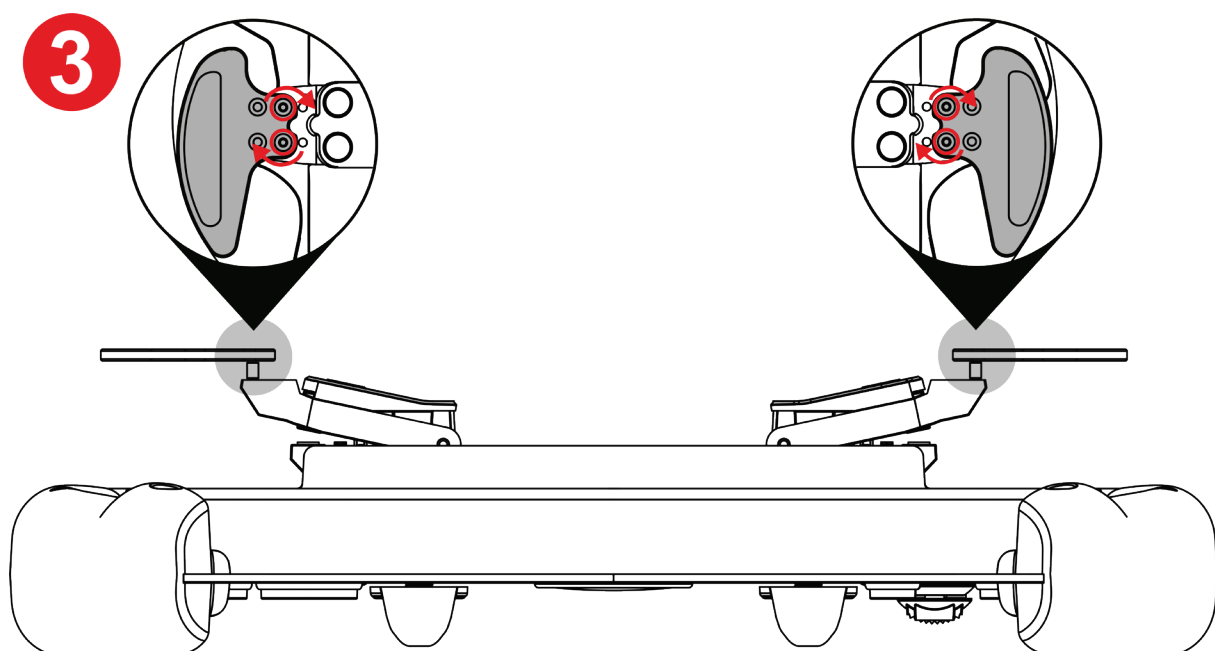

3 Draai de vier schroeven van de paddle shifters vast met de bijgeleverde Torx-sleutel.



Hoe kan ik het bereik tussen paddle shifters aanpassen

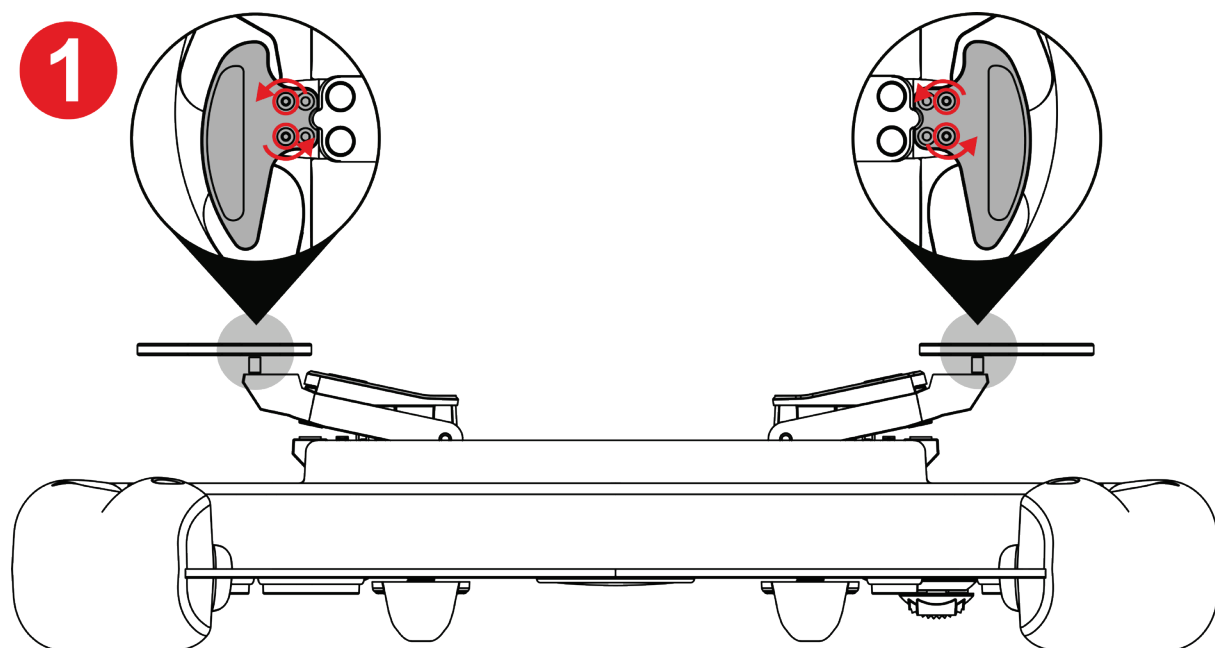

1 Draai de vier schroeven van de paddle shifter los met de bijgeleverde Torx-sleutel.

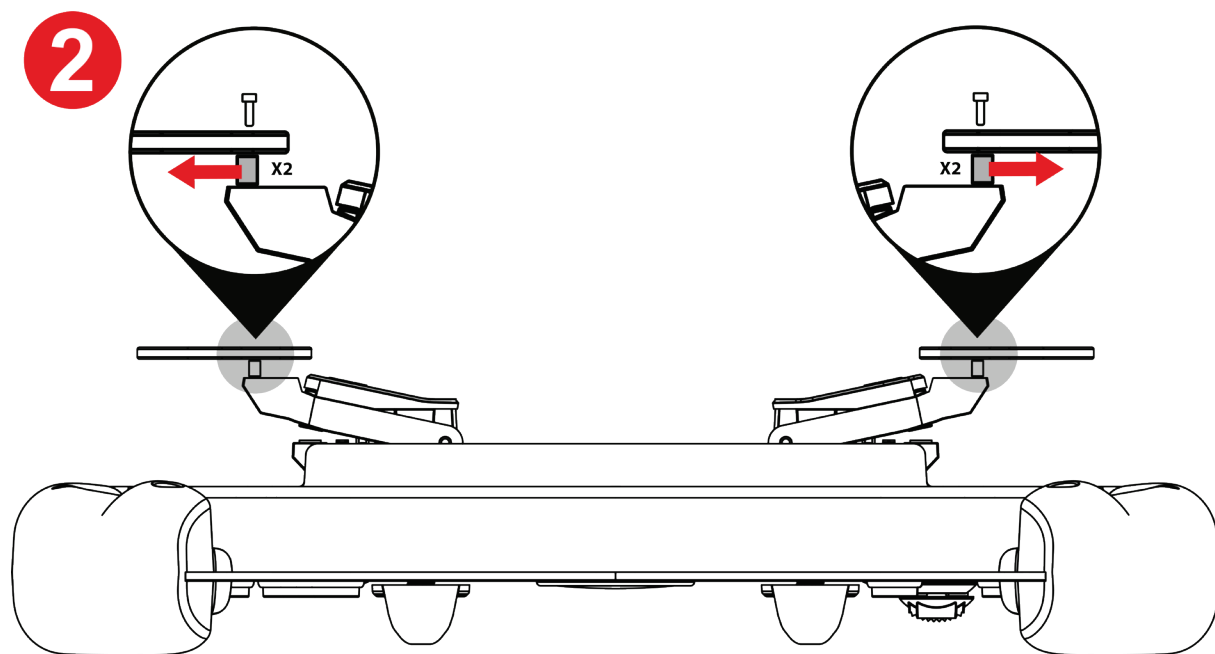

2 Verwijder de afstandstukken.

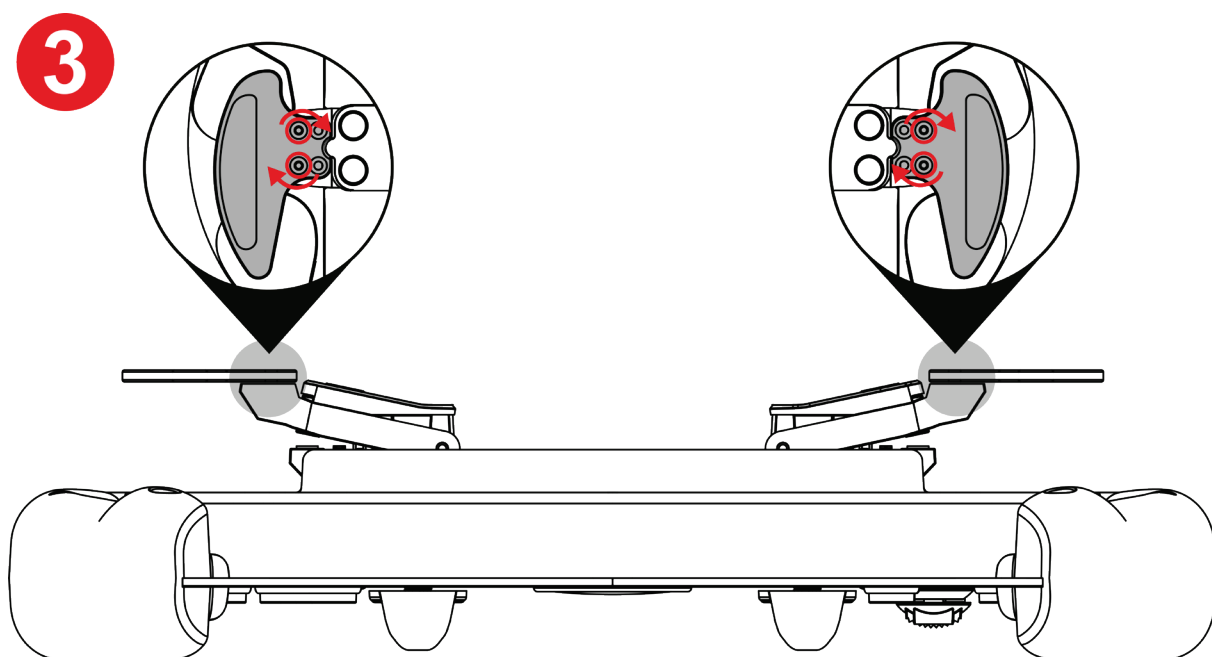

3 Draai de vier schroeven van de paddle shifters vast met de bijgeleverde Torx-sleutel.



Hoe kan ik de magnetische gevoeligheid en het geluidsniveau van de paddle shifters aanpassen

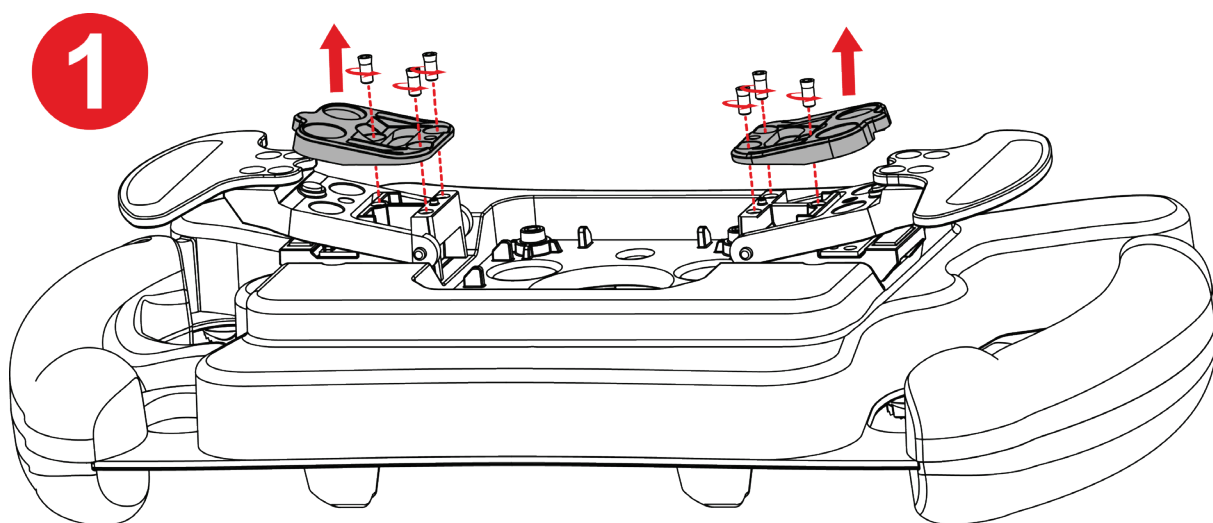

1 Verwijder de magnetische stops door de zes aanslagschroeven los te draaien met behulp van de meegeleverde Torx-sleutel.

2

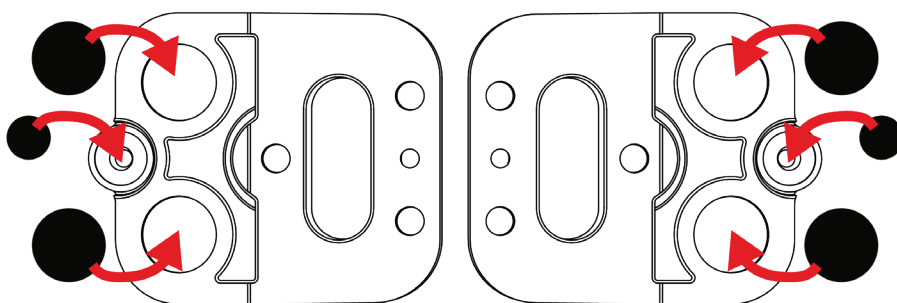
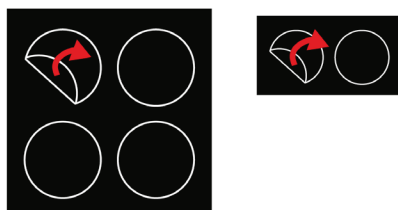

2 Trek de meegeleverde pads eraf en bevestig ze op de juiste plaatsen onder de magnetische stops.



Raadpleeg de tabel **Magnetische gevoeligheid en geluidsdemping voor paddle shifters** voor mogelijke configuraties en hun effecten.



3

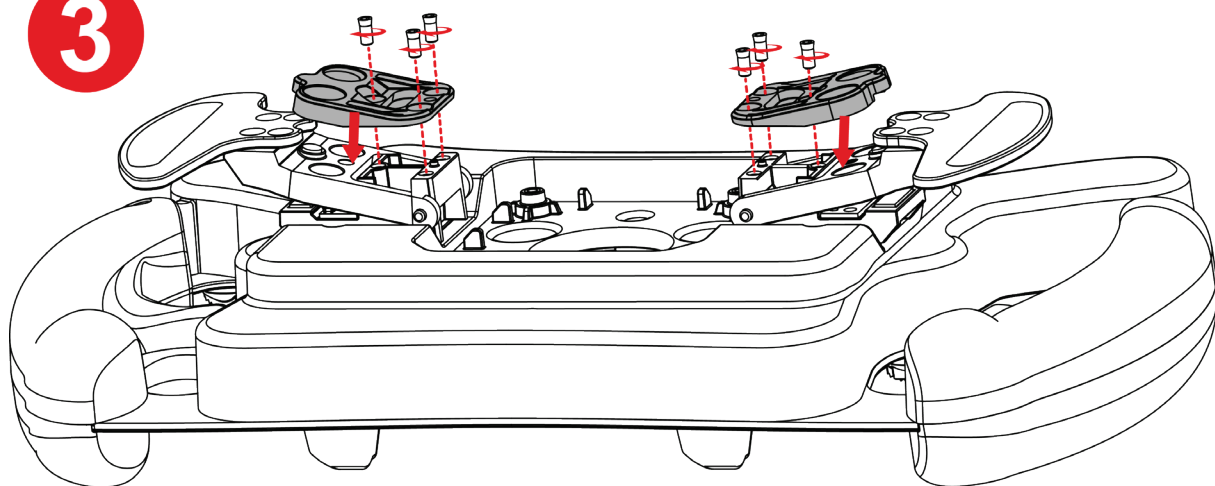

3 Installeer de magnetische stops weer en draai de zes aanslagschroeven vast met de meegeleverde Torx-sleutel.

Magnetische gevoeligheid en geluiddempingstabel voor paddle shifters

	 (standaard)	 2	 4
Magnetische gevoeligheid			
Geluid			



8. FAQ en technische ondersteuning

Heeft u vragen over de Ferrari 488 GT3 Wheel Add-On, of ondervindt u technische problemen? Bezoek dan de website voor technische ondersteuning van Thrustmaster:

<https://support.thrustmaster.com/product/ferrarif488gt3addon>.

Op deze pagina kunt u ook de firmware van het stuur bijwerken.



THRUSTMASTER®

FERRARI 488 GT3 WHEEL ADD-ON

PC (Windows 10/11)

PS4™ / PS5™

Xbox Series / Xbox One

Manuale d'uso



Leggi attentamente le istruzioni fornite nel presente manuale **prima** di installare il prodotto, **prima** di qualsiasi uso del prodotto e **prima** di qualsiasi intervento di manutenzione. Assicurati di rispettare le istruzioni sulla sicurezza. Il mancato rispetto di tali istruzioni potrebbe causare incidenti e/o danni. Conserva questo manuale, in modo tale da poterne consultare le istruzioni in futuro.

INDICE

1.	CONTENUTO DELLA CONFEZIONE	5
2.	CARATTERISTICHE	6
3.	INFORMAZIONI SULL'USO DEL VOLANTE	8
4.	INSTALLAZIONE DEL SUPPORTO A SGANCIO RAPIDO	13
	<i>Installazione del supporto a sgancio rapido per base a chiavistello</i>	<i>14</i>
	<i>Installazione del supporto a sgancio rapido per base a vite</i>	<i>17</i>
5.	MAPPATURA.....	21
	<i>Mappatura per PC.....</i>	<i>21</i>
	<i>Mappatura per PS4™/PS5™</i>	<i>22</i>
	<i>Mappatura per Xbox Series/Xbox One</i>	<i>23</i>
6.	FUNZIONAMENTO DEI LED.....	24
	<i>Come entrare/uscire dal menu LED</i>	<i>25</i>
	<i>Come regolare l'intensità dei LED.....</i>	<i>27</i>

Come cambiare la modalità LED: GT3 o

Formula28

7. PERSONALIZZAZIONE DELLE LEVE DEL CAMBIO.....29

Come regolare l'ampiezza delle leve del cambio31

Come regolare la raggiungibilità delle leve del cambio.....33

Come regolare la sensibilità magnetica e il livello del suono delle leve del cambio35

8. FAQ E ASSISTENZA TECNICA.....37



FERRARI 488 GT3 WHEEL ADD-ON

Entra nella leggenda delle gare GT con il Ferrari 488 GT3 Wheel Add-On, un volante concepito per le prestazioni e compatibile con tutte le basi per volanti Thrustmaster.

Questo manuale ti aiuterà a installare e utilizzare al meglio il tuo Ferrari 488 GT3 Wheel Add-On. Prima di iniziare a guidare, leggi attentamente le istruzioni e le avvertenze: ti aiuteranno a goderti al massimo il tuo prodotto.



1. Contenuto della confezione

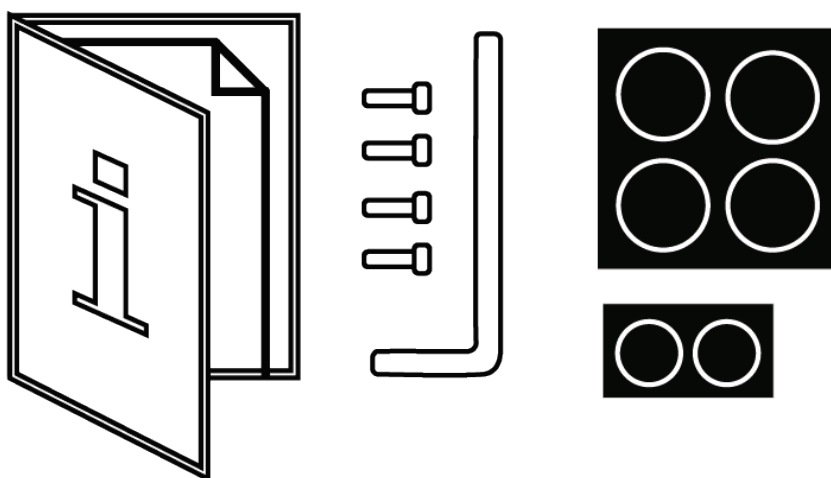
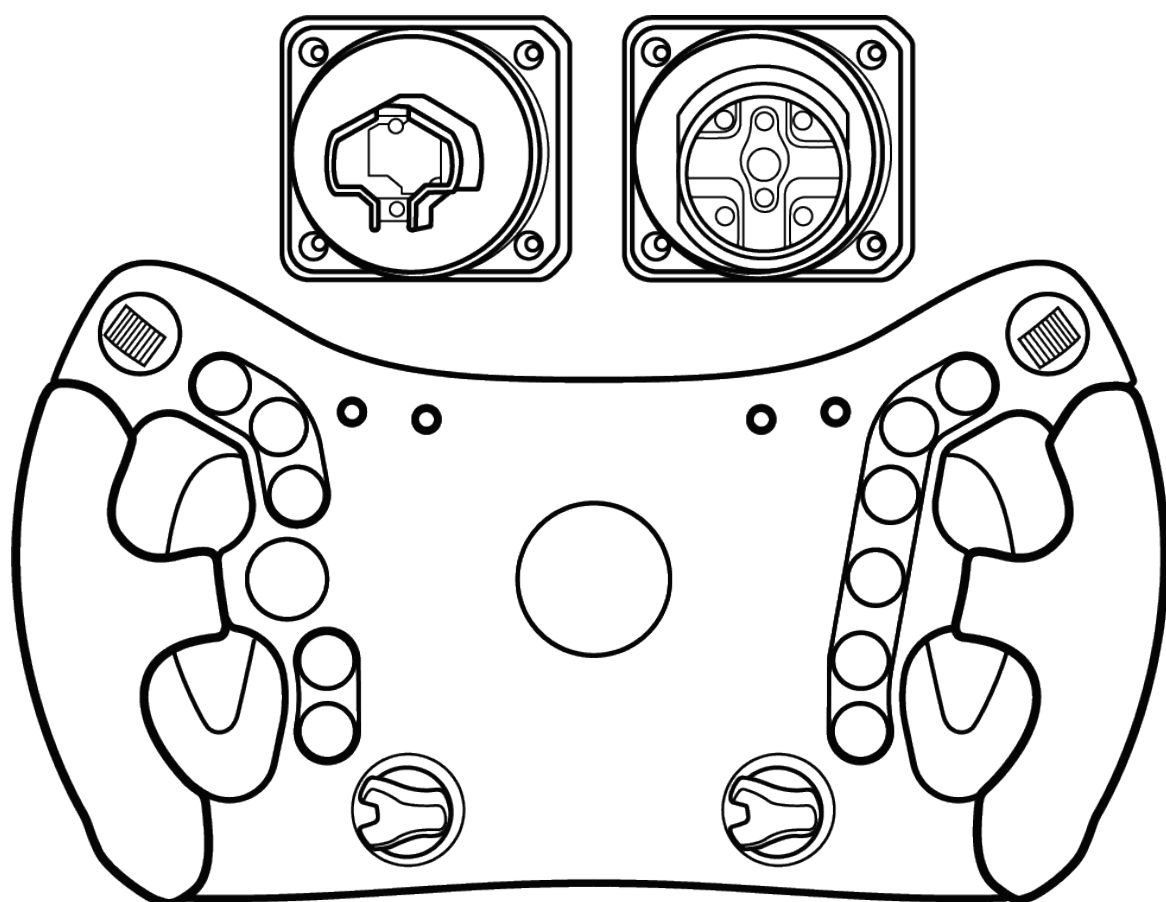



2. Caratteristiche

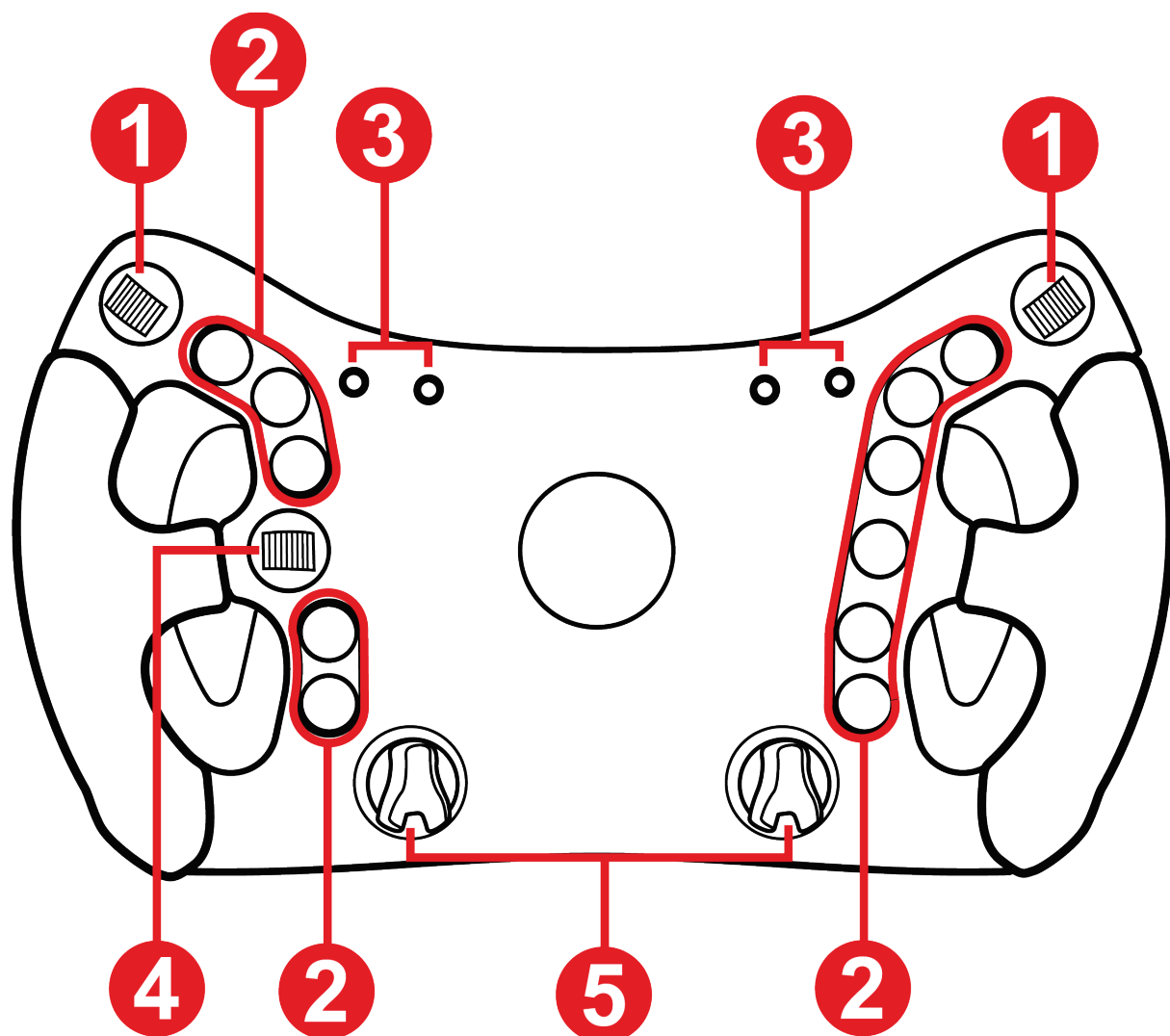

- ❶ Selettori da pollice
- ❷ 11 pulsanti azione
- ❸ LED giri/min e dati di gara (bandiere, box)
- ❹ D-pad
- ❺ Selettori rotanti

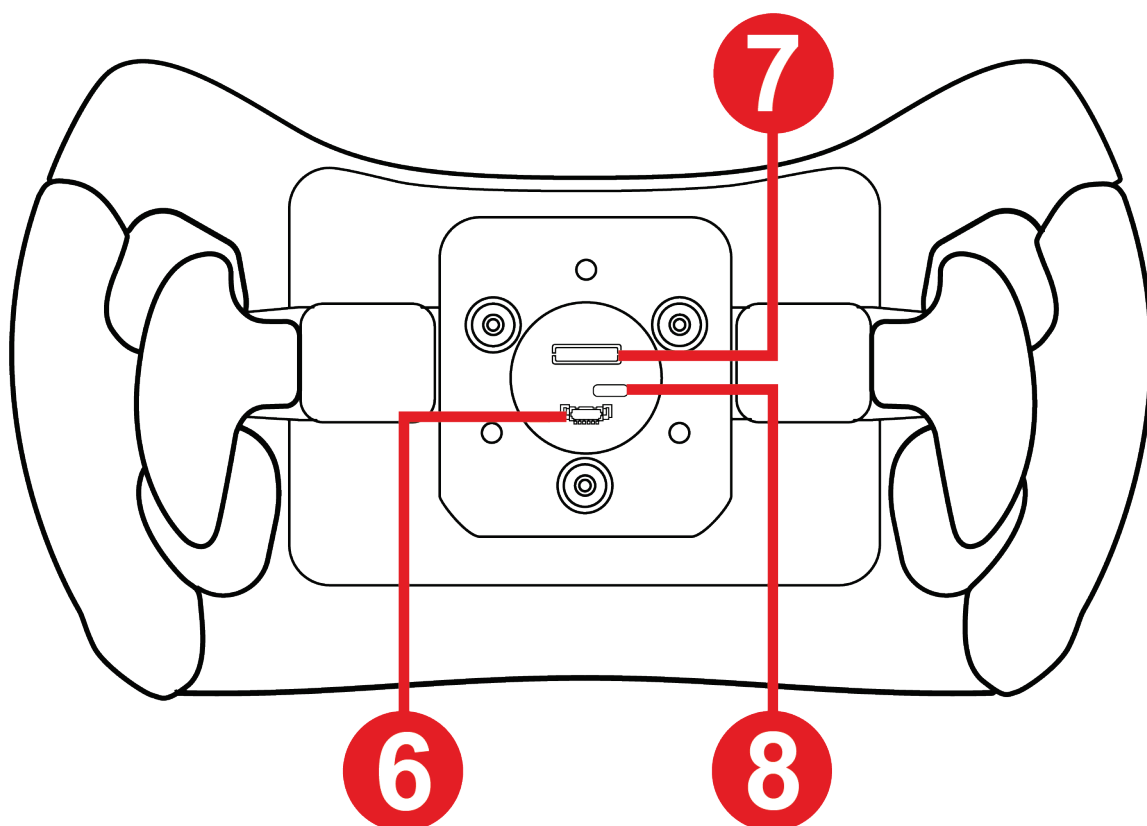

⑥ Porta di connessione per il supporto a sgancio rapido per base a vite

⑦ Porta di connessione per il supporto a sgancio rapido per base a chiavistello

⑧ Porta USB-C (in caso sia necessario aggiornare il firmware – cavo non incluso)

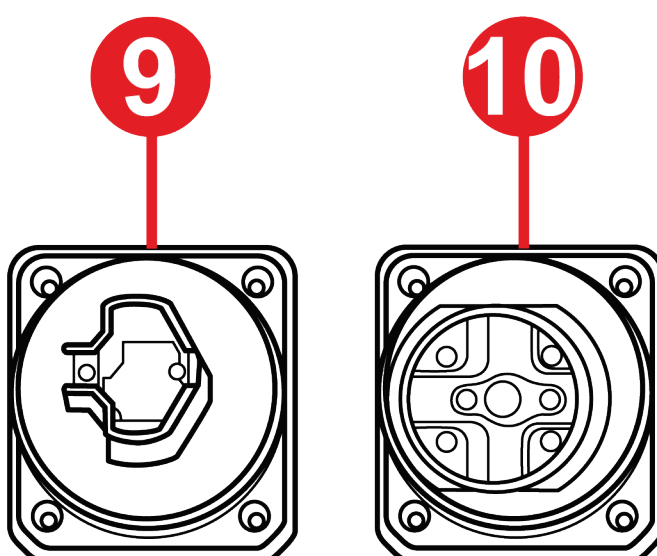

⑨ Supporto a sgancio rapido per base a chiavistello

⑩ Supporto a sgancio rapido per base a vite



3. Informazioni sull'uso del volante



Documentazione

Prima di utilizzare questo prodotto, rileggi con attenzione la presente documentazione, conservandola per una futura consultazione.



Shock elettrico

- Conserva questo prodotto in un luogo asciutto, al riparo dalla polvere o dalla luce solare.
- Non torcere e non tirare i connettori e i cavi.
- Rispetta il verso per il collegamento dei connettori.
- Non versare alcun liquido sul prodotto o sui suoi connettori.
- Non cortocircuitare il prodotto.
- Non smontare mai il prodotto (eccezion fatta per le possibili personalizzazioni descritte nel presente manuale); non cercare di dargli fuoco e non esporlo alle alte temperature.
- Non aprire la periferica: al suo interno non vi sono componenti utili all'utente. Qualsiasi riparazione deve essere eseguita dal produttore, da una specifica agenzia o da un tecnico qualificato.



Rendere sicura l'area di gioco

- Nell'area di gioco, non posizionare alcun oggetto che possa interferire con la pratica dell'utente, o che possa provocare un movimento inappropriato o un'interruzione da parte di un'altra persona (una tazza di caffè, un telefono o delle chiavi, ad esempio).
- Non coprire i cavi di alimentazione con tappeti o moquette, coperte o qualsiasi altro oggetto, e non far passare i cavi dove la gente camminerà.



Infortunati causati dal Force Feedback e da movimenti ripetuti

L'uso di un volante Force Feedback potrebbe causare dolori muscolari o alle articolazioni. Per evitare qualsiasi problema:

- Riscaldati in anticipo ed evita lunghi periodi di allenamento.
- Prenditi una pausa di 10 – 15 minuti dopo ogni ora di allenamento.
- Qualora dovessi avvertire stanchezza o dolore alle mani, ai polsi, alle braccia, ai piedi o alle gambe, premi il pulsante di spegnimento del Force Feedback, spegni la base e riposati alcune ore prima di ricominciare ad allenarti.
- Se i sintomi o i dolori sopracitati dovessero persistere anche dopo aver riiniziato ad allenarti, smetti di allenarti e consulta il tuo medico.
- Non impostare il Force Feedback a un livello troppo alto rispetto alla tua esperienza e alla tua condizione fisica.
- Tieni il prodotto lontano dalla portata delle persone con età inferiore ai 16 anni.
- Assicurati che la base e il volante siano montati correttamente, in base alle istruzioni riportate nel presente manuale.



Rischio di potenti e rapide rotazioni impreviste: non far passare mai una mano o un braccio nelle aperture del volante o nella traiettoria di rotazione del volante.

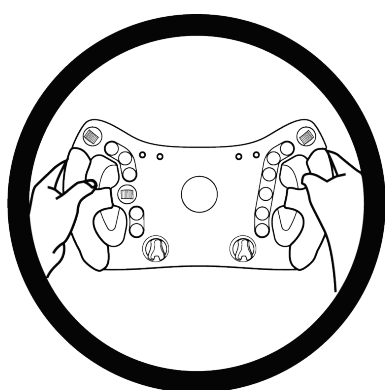

Mentre usi il prodotto, lascia sempre entrambe le mani correttamente posizionate sul volante, senza mai lasciarlo andare del tutto.



Prodotto maneggiabile solo da persone con **almeno 16 anni di età**.



4. Installazione del supporto a sgancio rapido

Il **Ferrari 488 GT3 Wheel Add-On** viene fornito assieme a due supporti a sgancio rapido corrispondenti ai formati delle basi Thrustmaster.

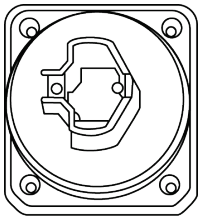
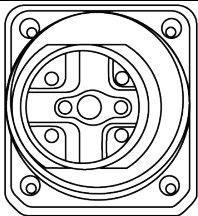
Sistema	Compatibilità
 <p>Supporto a sgancio rapido per base a chiavistello.</p>	T818, T818 Ferrari SF1000 Simulator e future basi Thrustmaster.
 <p>Supporto a sgancio rapido per base a vite</p>	T-GT / T-GT II Servo Base, T300 RS Servo Base, TS PC Racer, TS-XW, TX Racing Wheel Servo Base, TS-XW Servo Base.



Prima di ogni utilizzo, verifica che il **Ferrari 488 GT3 Wheel Add-On** sia correttamente agganciato al supporto, così come indicato dalle istruzioni riportate nel manuale della base.



Installazione del supporto a sgancio rapido per base a chiavistello

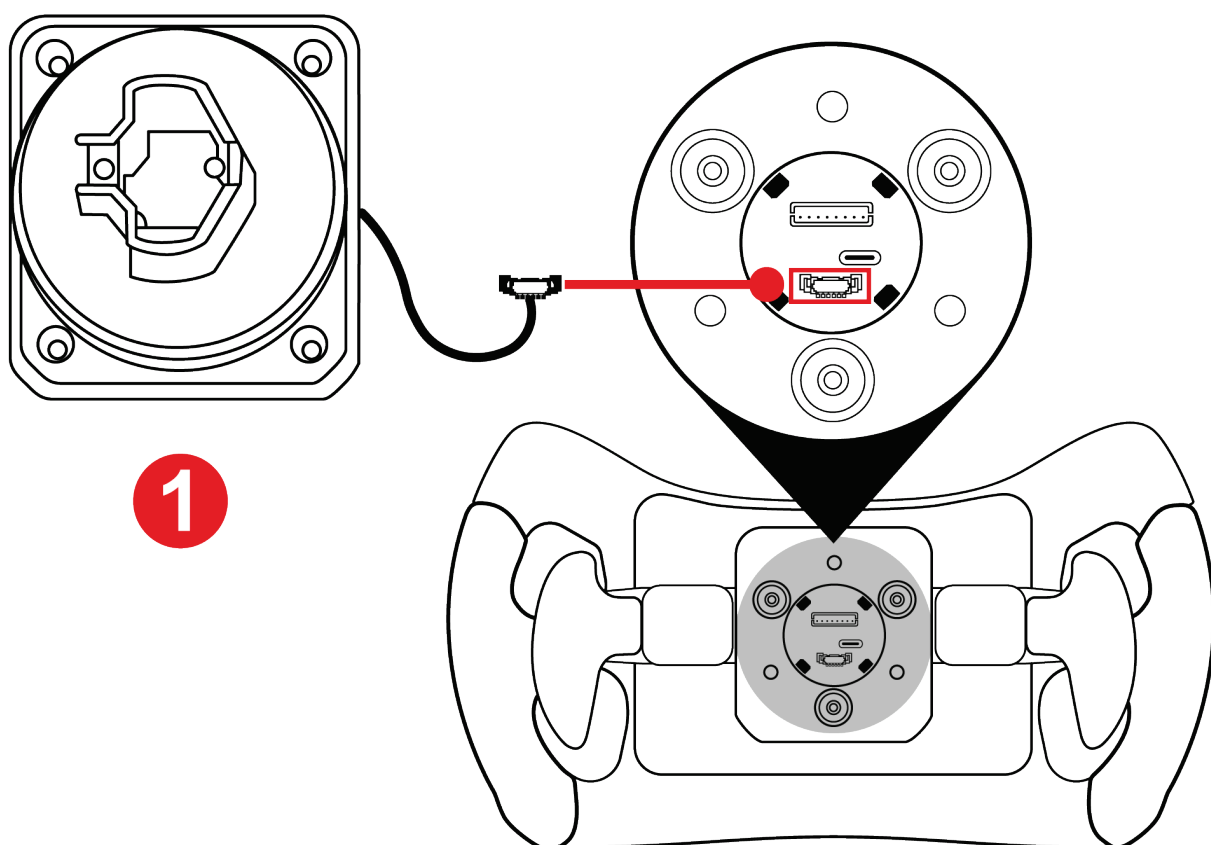

1 Inserisci il connettore del supporto a sgancio rapido nella corrispondente porta sul retro del volante.



Per evitare di schiacciare il cavo, avvolgilo nel relativo alloggiamento prima di avvitare il supporto.

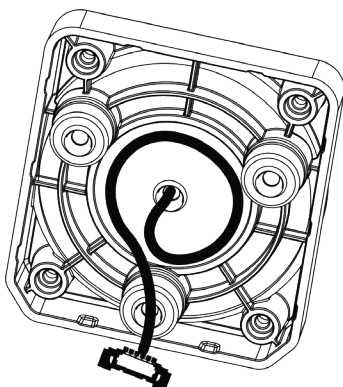

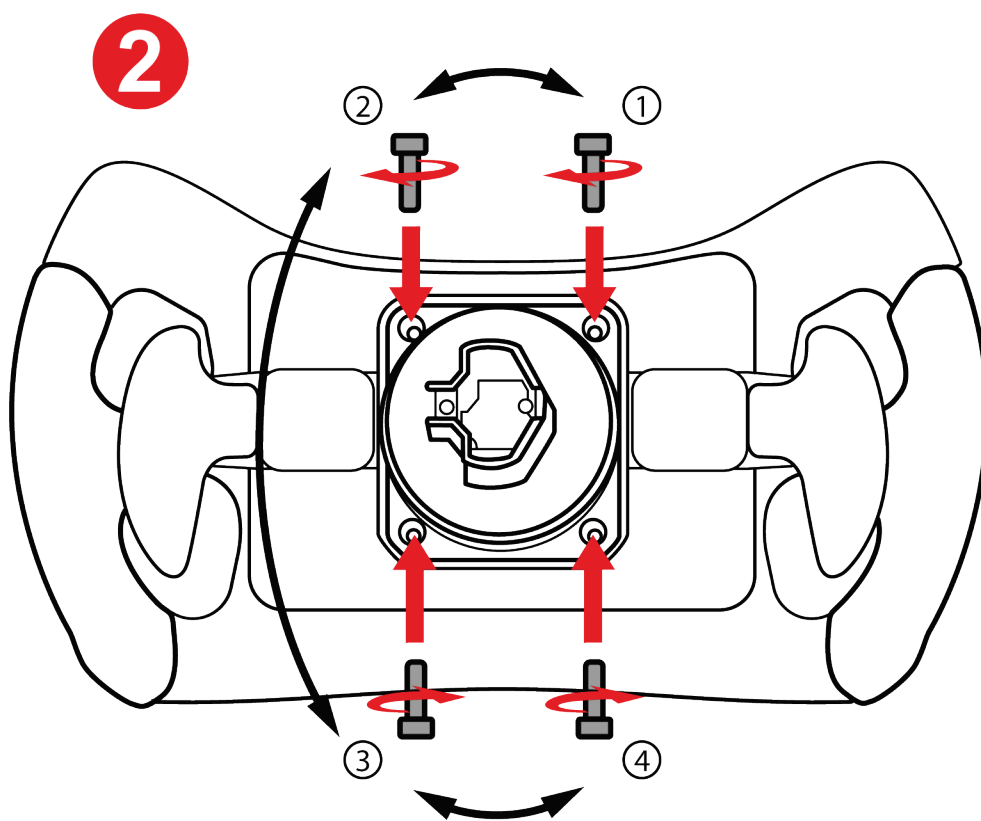

2 Inserisci il supporto a sgancio rapido e stringilo utilizzando la chiave Torx acclusa.



Quando installi il supporto, non stringere troppo le viti.

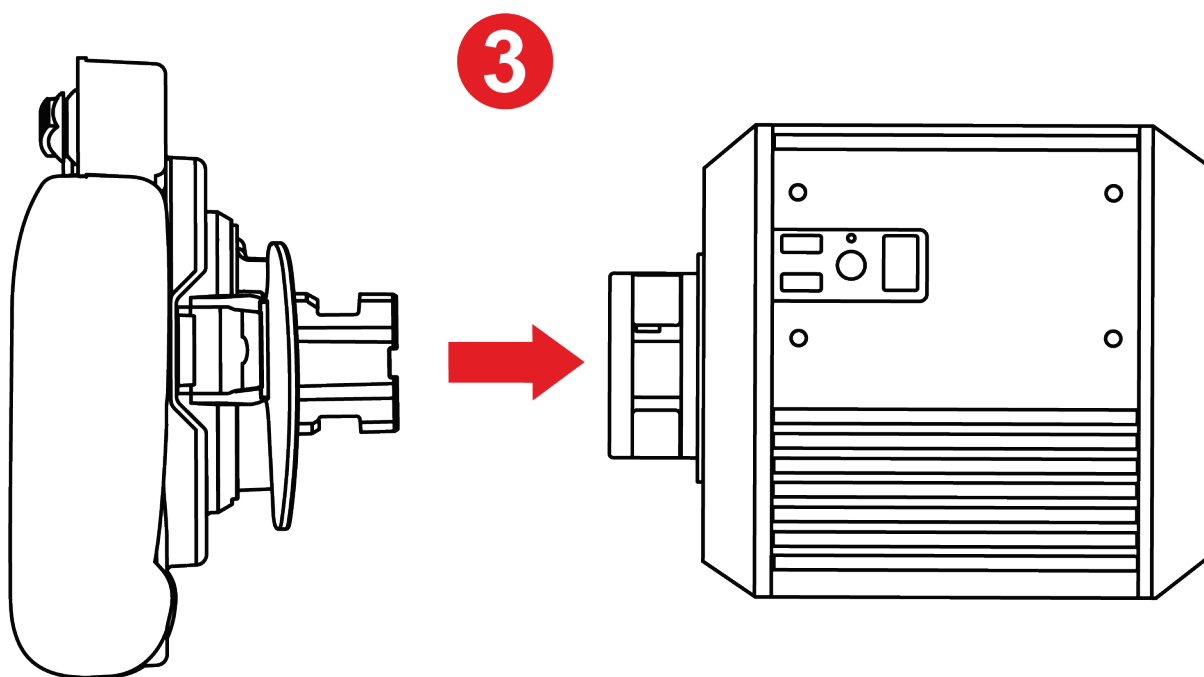

3 Inserisci il volante nella base.



Segui la procedura di installazione descritta nel manuale d'uso della base.



Installazione del supporto a sgancio rapido rapido per base a vite

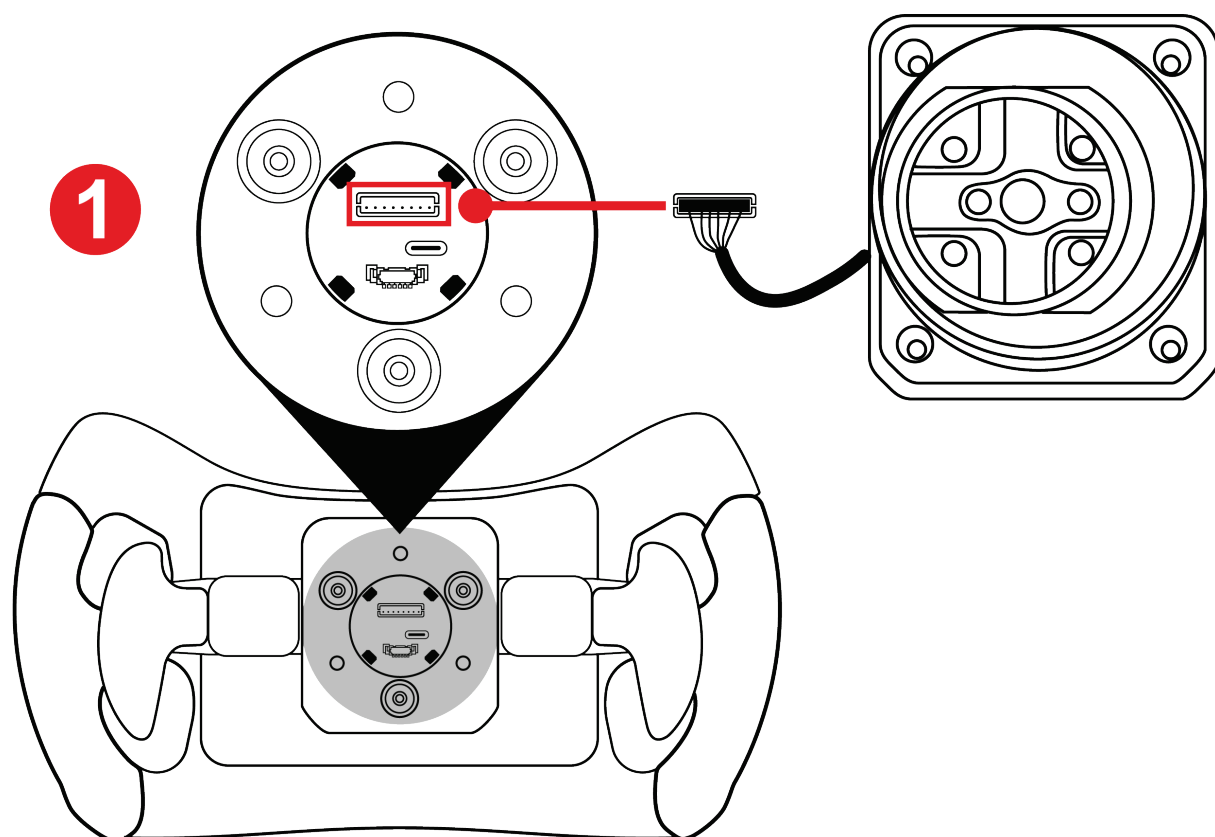

1 Inserisci il connettore del supporto a sgancio rapido nella corrispondente porta sul retro del volante.



Per evitare di schiacciare il cavo, avvolgilo nel relativo alloggiamento prima di avvitare il supporto.

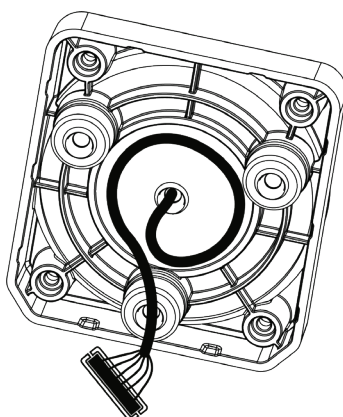

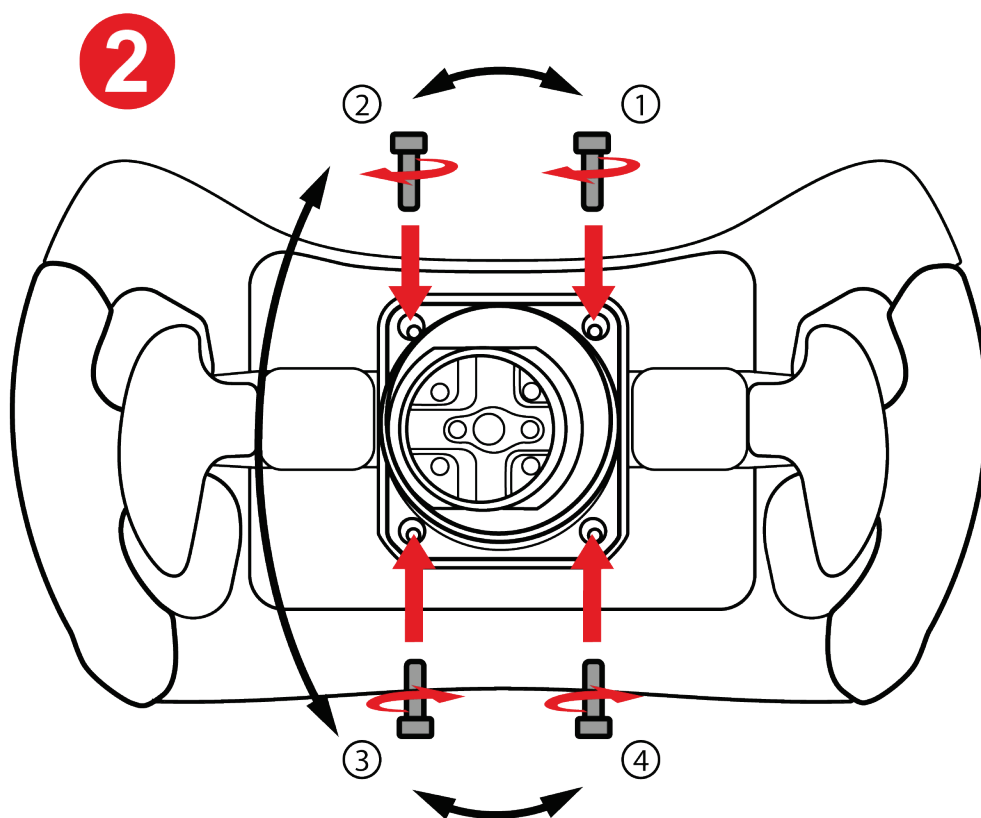

2 Inserisci il supporto a sgancio rapido e stringilo utilizzando la chiave Torx acclusa.



Quando installi il supporto, non stringere troppo le viti.

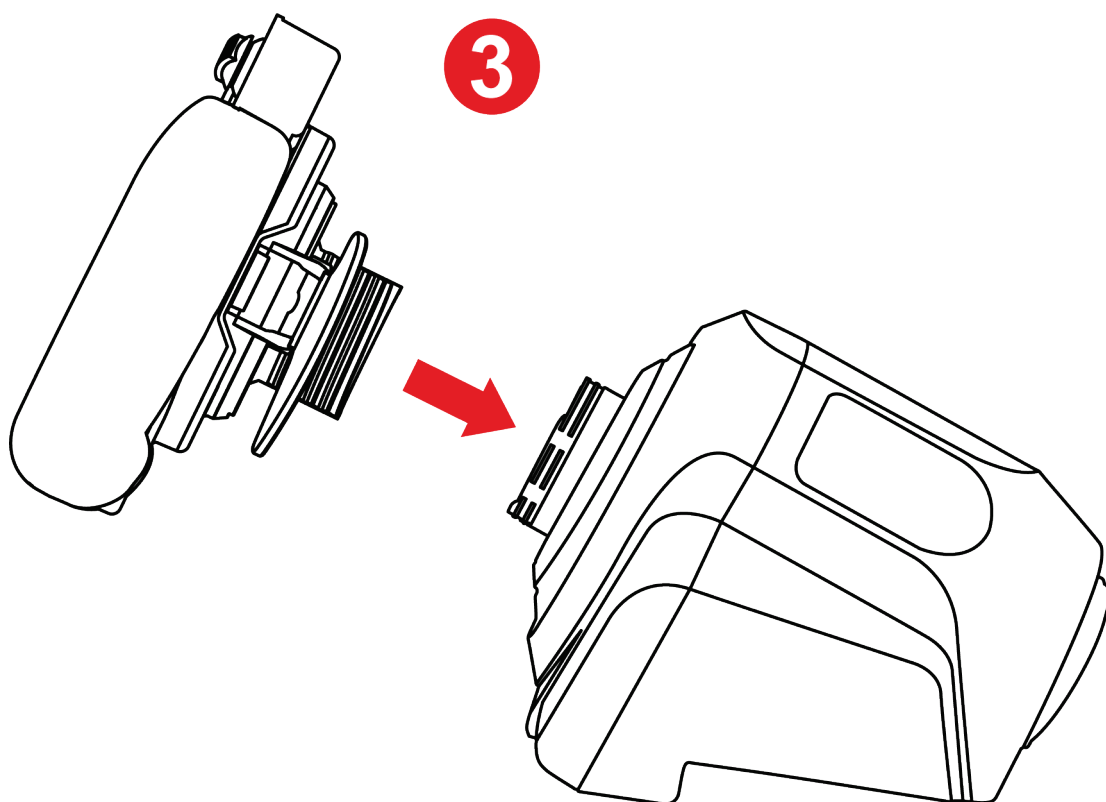

3 Inserisci il volante nella base.



Segui la procedura di installazione descritta nel manuale d'uso della base.



Se desideri utilizzarlo assieme a una base T818, non collegare mai il Quick Release Adapter (fornito assieme alla base T818, venduta separatamente) al supporto a sgancio rapido per base a vite.

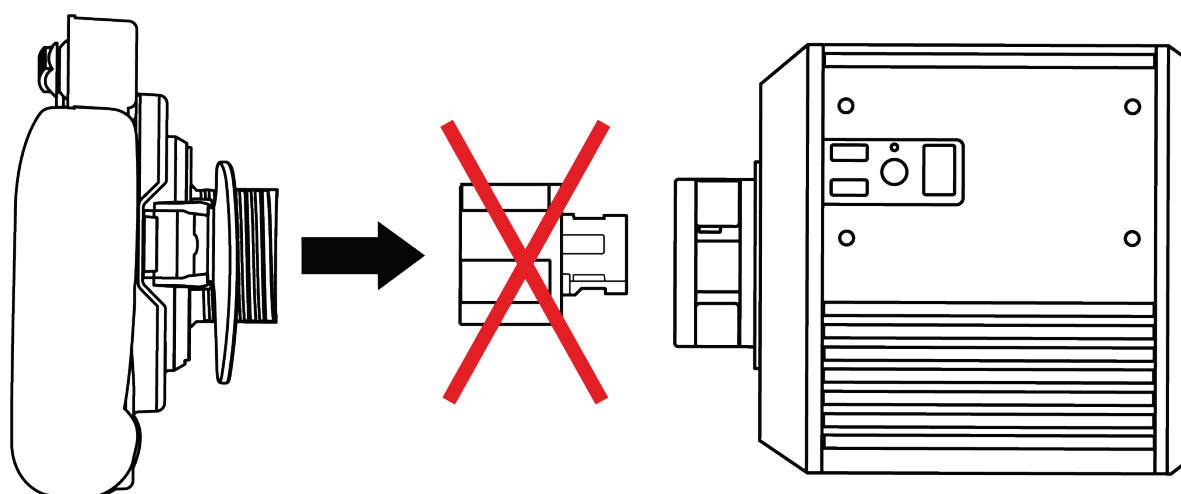
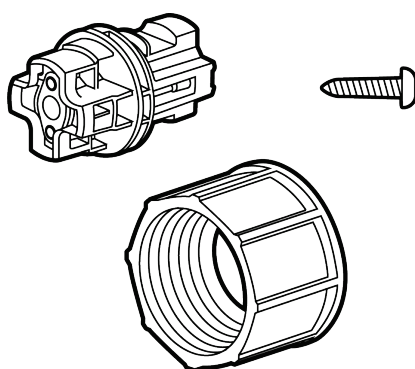

Per utilizzarlo assieme a una base T818 base o a una dotata di connettore per basi a chiavistello, utilizza unicamente il **supporto a sgancio rapido per basi a chiavistello** fornito assieme al **Ferrari 488 GT3 Wheel Add-On**.



5. Mappatura

Mappatura per PC

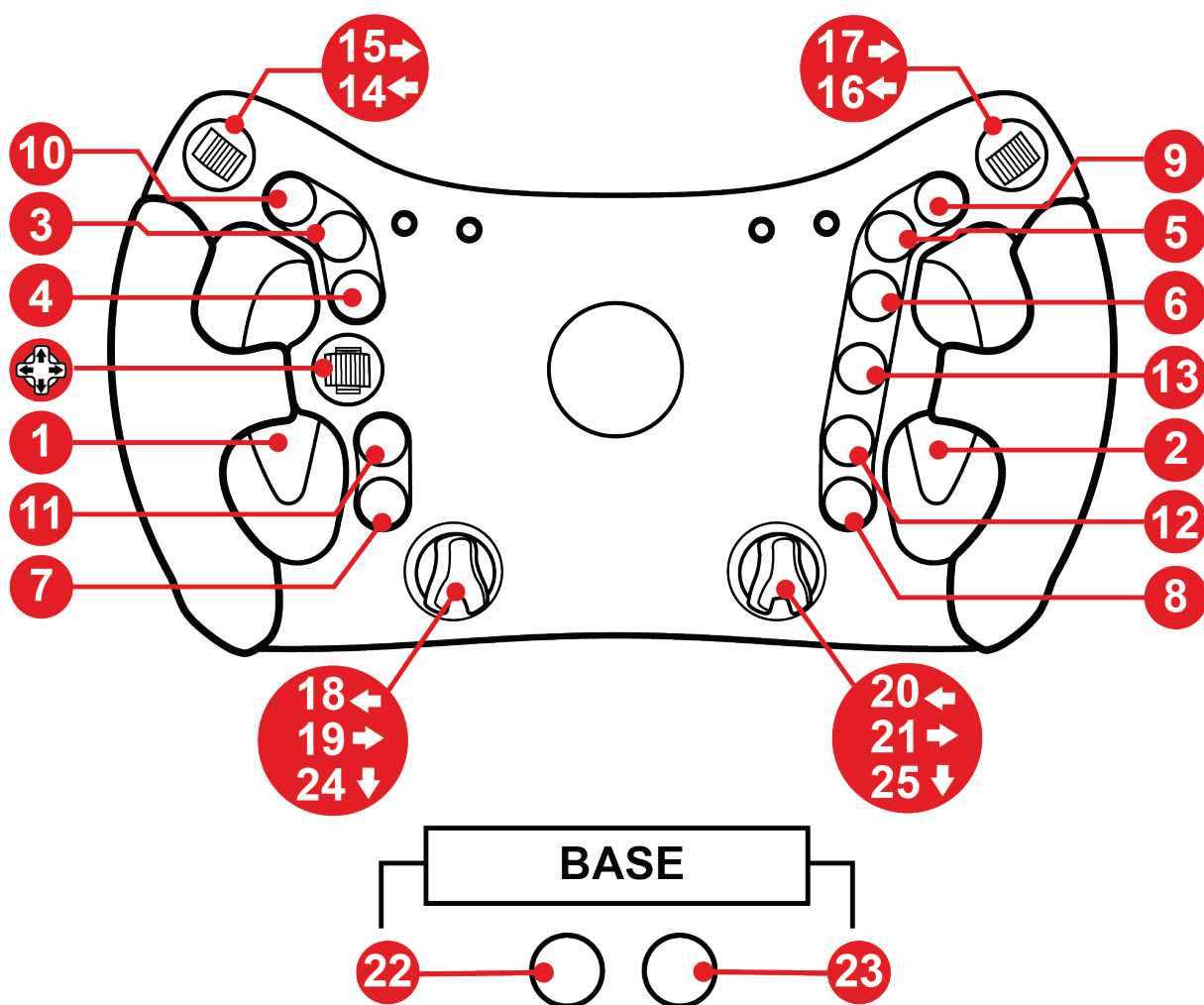



Mappatura per PS4™/PS5™

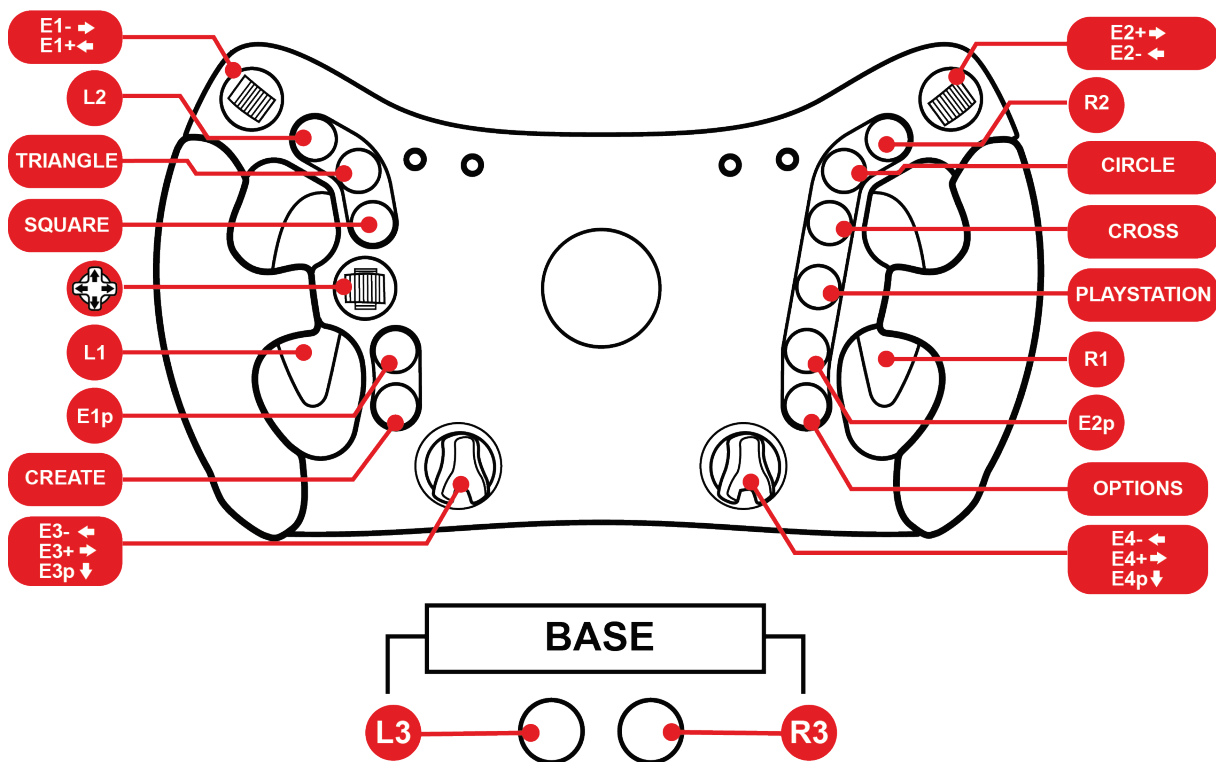



Mappatura per Xbox Series/Xbox One

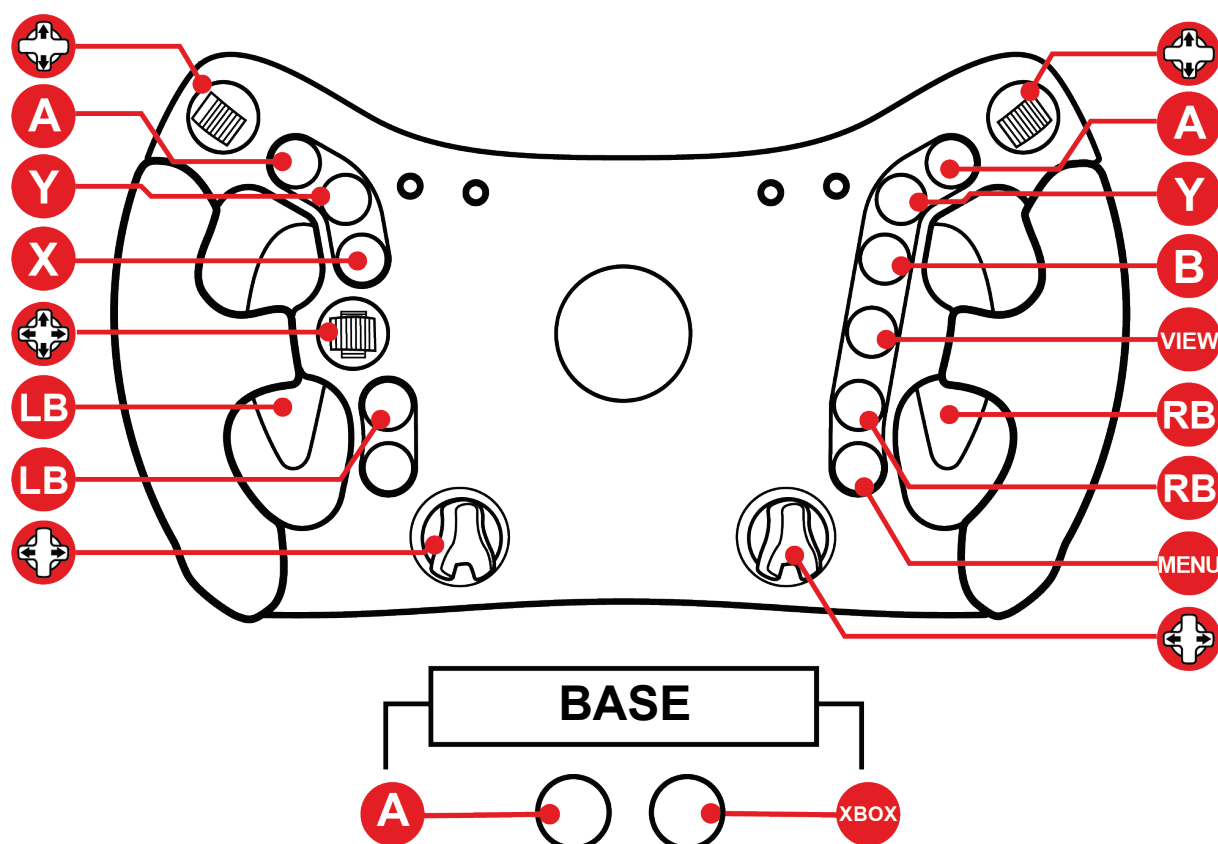

Su Xbox Series e Xbox One:

- I LED del Ferrari 488 GT3 Wheel Add-On non funzionano per via dei protocolli di restrizione della console.
- Alcune funzioni (selettori, numero di pulsanti) vengono limitate dai protocolli della console.



6. Funzionamento dei LED

Il **Ferrari 488 GT3 Wheel Add-On** visualizza i dati di gara tramite i LED: bandiere, box e giri/min.

I dati visualizzati sono personalizzabili (intensità e colore dei LED per i giri/min), a seconda della modalità (GT3 o Formula).

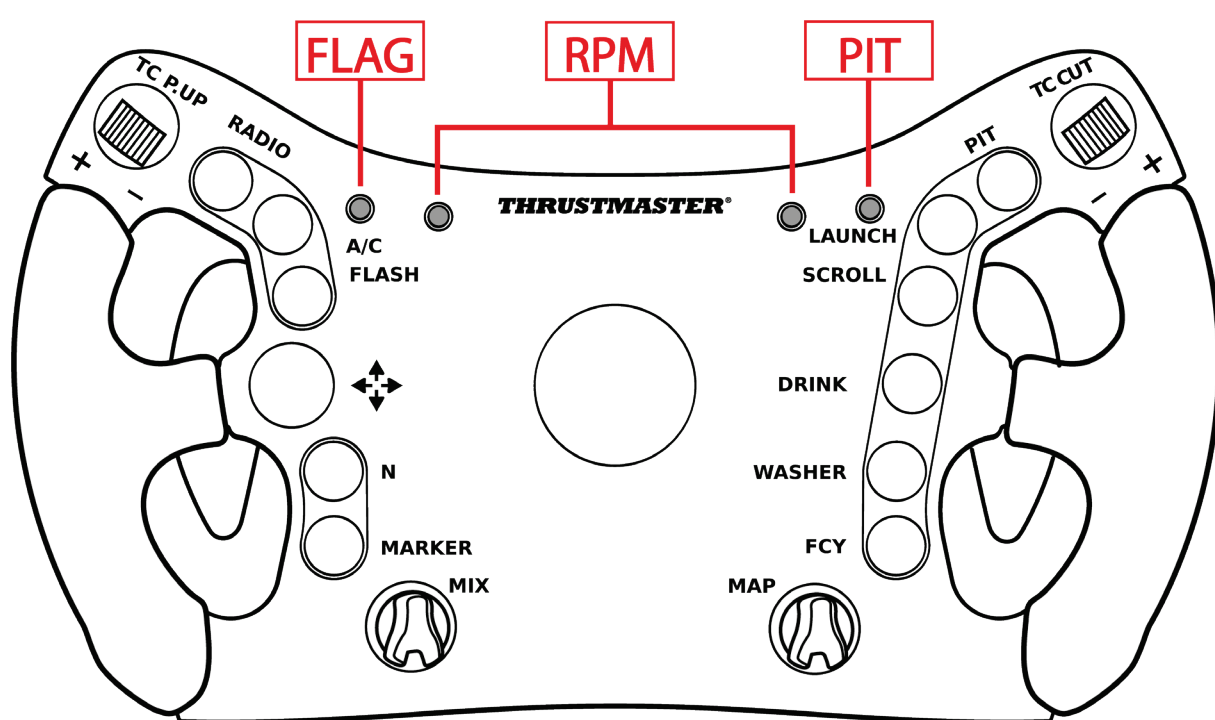

I LED funzionano su PC e PS4™/PS5™.

Su Xbox Series e Xbox One, i LED non funzionano per via dei protocolli di restrizione della console.



Come entrare/uscire dal menu LED

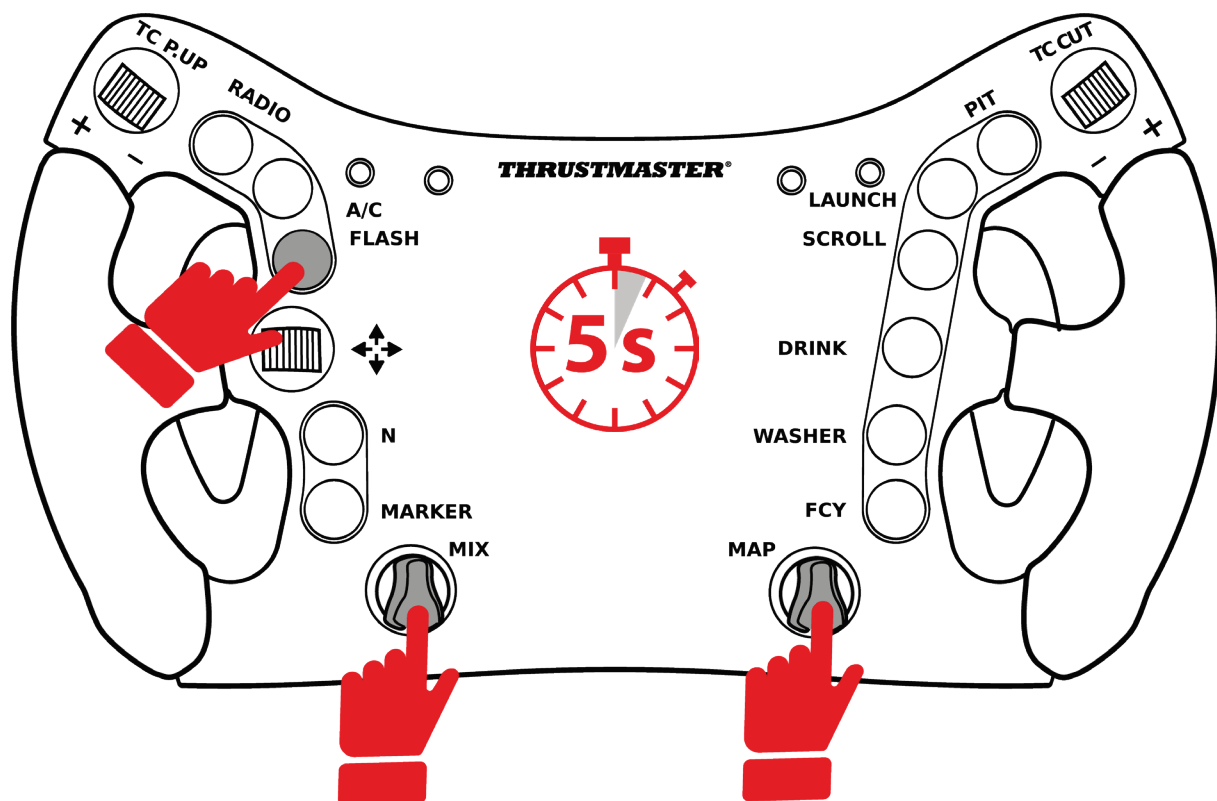

- Per entrare nel menu LED, tieni premuti simultaneamente il pulsante **FLASH** ed entrambi i **selettori rotanti per 5 secondi**, dopodiché rilasciali.
- Per uscire dal menu LED, premi simultaneamente il pulsante **FLASH** ed entrambi i **selettori rotanti**, dopodiché rilasciali.



FLAG

RPM

PIT



Accesso al menu LED: i LED FLAG e PIT e uno dei LED giri/min (rosso a sinistra o blu a destra) si accendono.



Uscita dal menu LED: tutti e quattro i LED sono spenti.



Come regolare l'intensità dei LED

- Accedi al menu LED tenendo premuti simultaneamente il pulsante **FLASH** ed entrambi i **selettori rotanti** per 5 secondi, dopodiché rilasciali.
- Ruota il **selettore sinistro (MIX)** verso sinistra per ridurre l'intensità, oppure verso destra per aumentarla.



- Esci dal menu LED premendo simultaneamente il pulsante **FLASH** ed entrambi i **selettori rotanti**, dopodiché rilasciali.



Come cambiare la modalità LED: GT3 o Formula

- Accedi al menu LED tenendo premuti simultaneamente il pulsante **FLASH** ed entrambi i **selettori rotanti** per 5 secondi, dopodiché rilasciali.
- Ruota il **selettore destro (MAP)** verso sinistra per selezionare la modalità GT3 (LED rosso), oppure verso destra per selezionare la modalità Formula (LED blu).



Modalità GT3 (modalità predefinita)



Modalità FORMULA

- Esci dal menu LED premendo simultaneamente il pulsante **FLASH** ed entrambi i **selettori rotanti**, dopodiché rilasciali.



7. Personalizzazione delle leve del cambio

Le leve del cambio del **Ferrari 488 GT3 Wheel Add-On** sono regolabili in **ampiezza e raggiungibilità**.

L'**ampiezza** consiste nel regolare in larghezza la leva del cambio, ossia modificando la distanza tra l'impugnatura del volante e la leva del cambio.

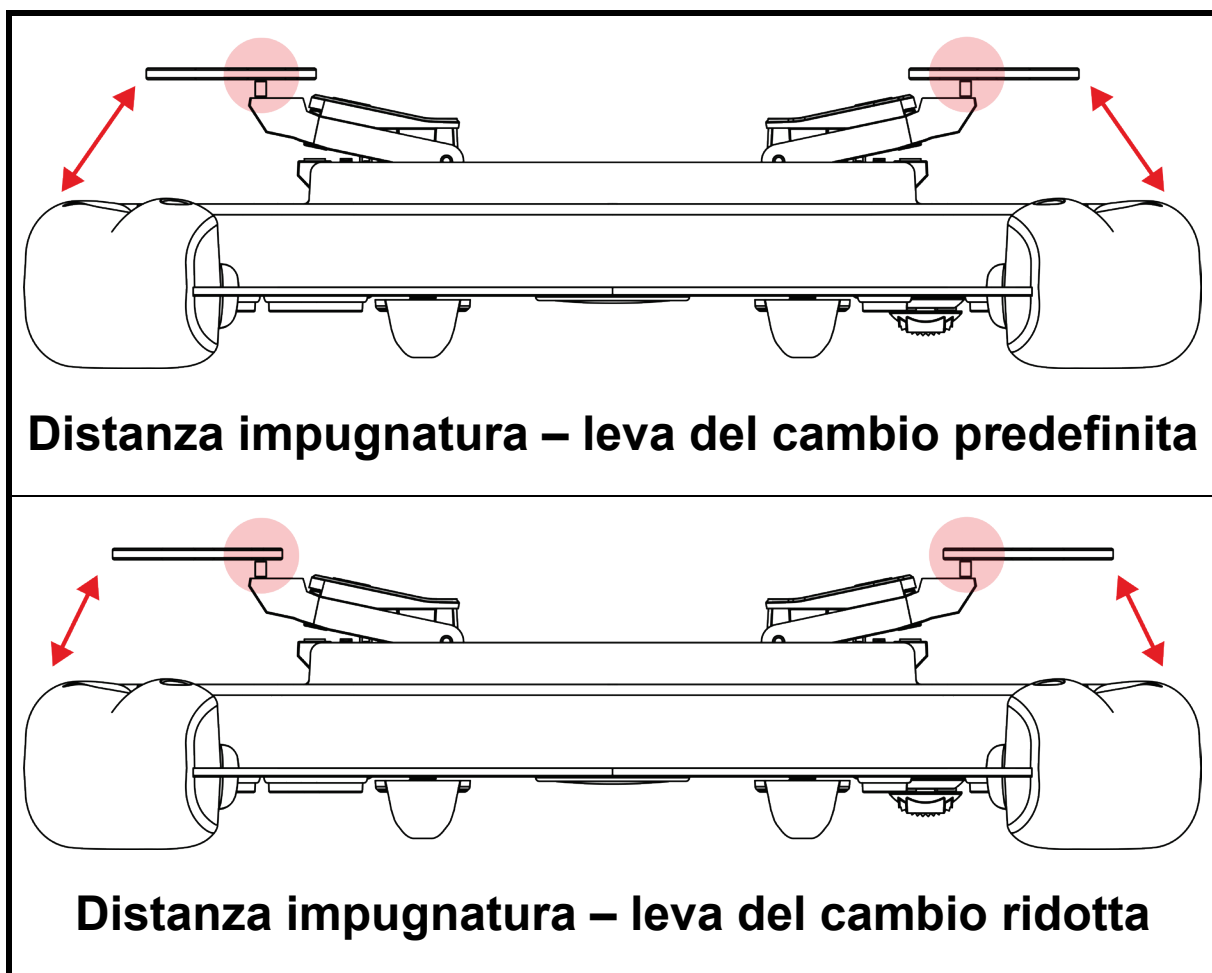



La regolazione della **raggiungibilità** tramite i distanziatori modifica la distanza di attivazione della leva del cambio.

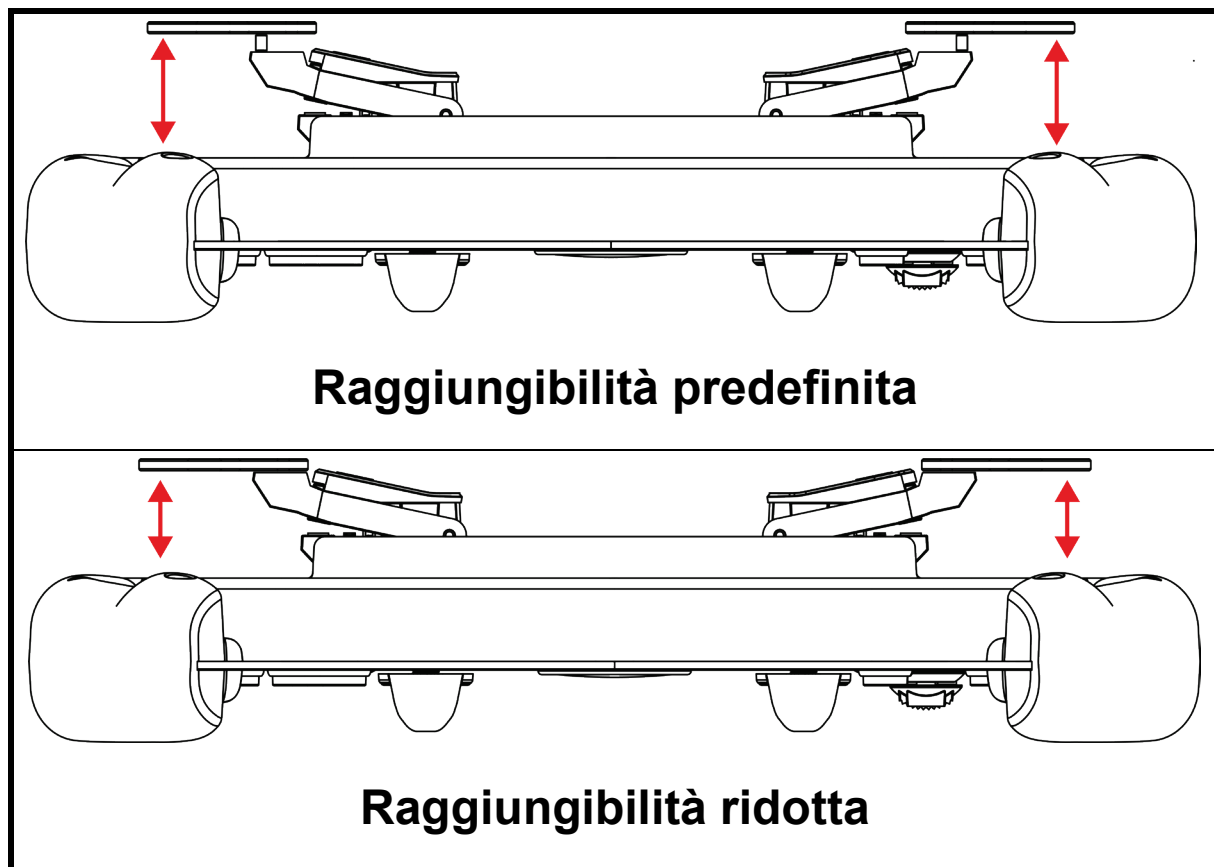

È inoltre possibile regolare la **sensibilità magnetica** e il **livello del suono** prodotto dalle leve del cambio, utilizzando l'accluso set di cuscinetti.

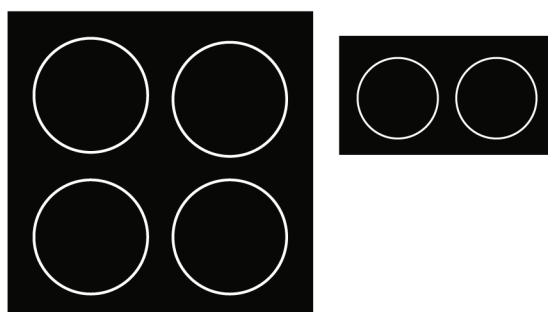



Come regolare l'ampiezza delle leve del cambio

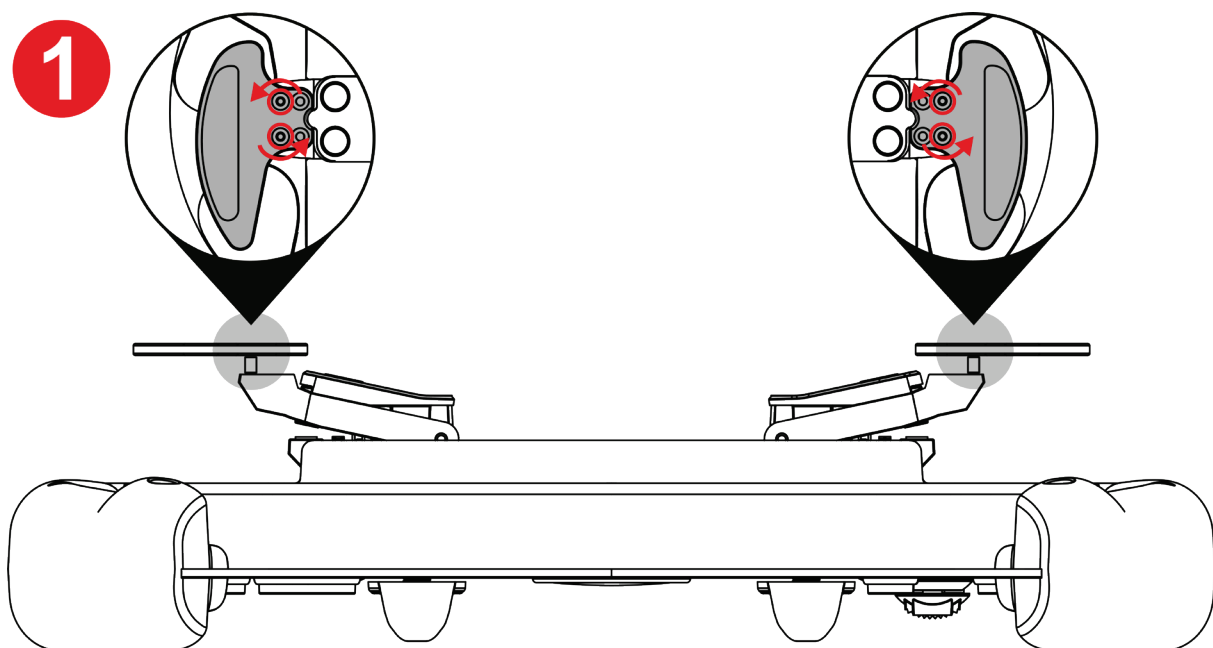

1 Svita le quattro viti delle leve del cambio utilizzando l'acclusa chiave Torx.

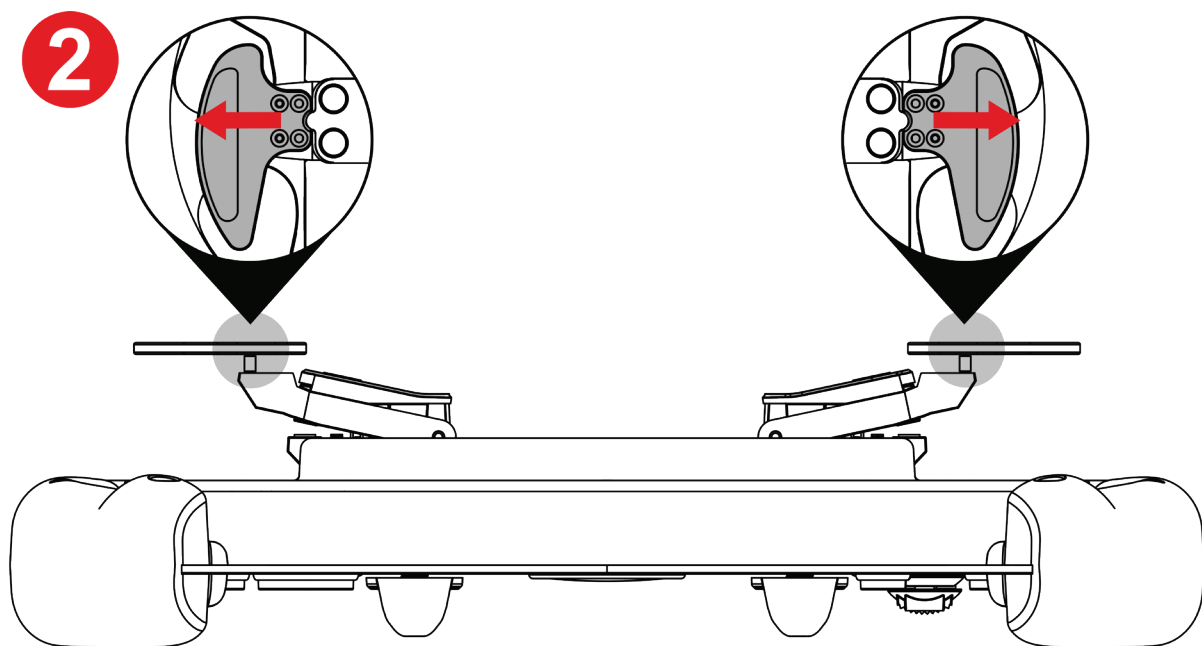

2 Sposta le leve del cambio verso l'esterno, in corrispondenza dei fori.

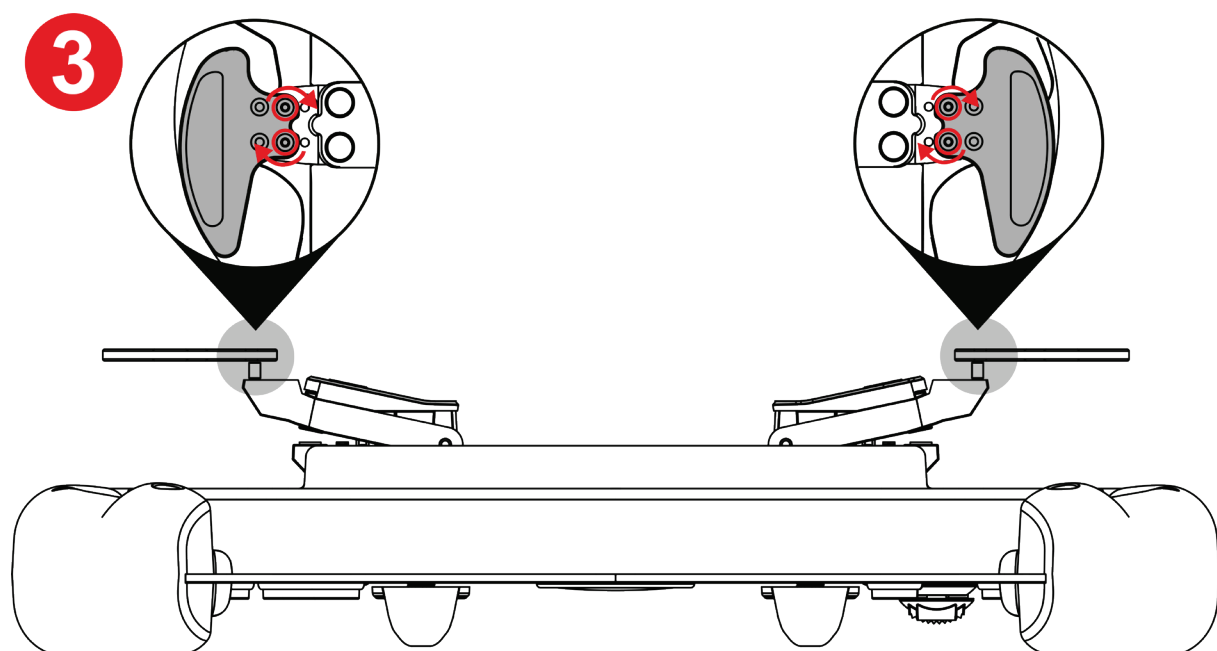

3 Stringi le quattro viti delle leve del cambio utilizzando l'acclusa chiave Torx.



Come regolare la raggiungibilità delle leve del cambio

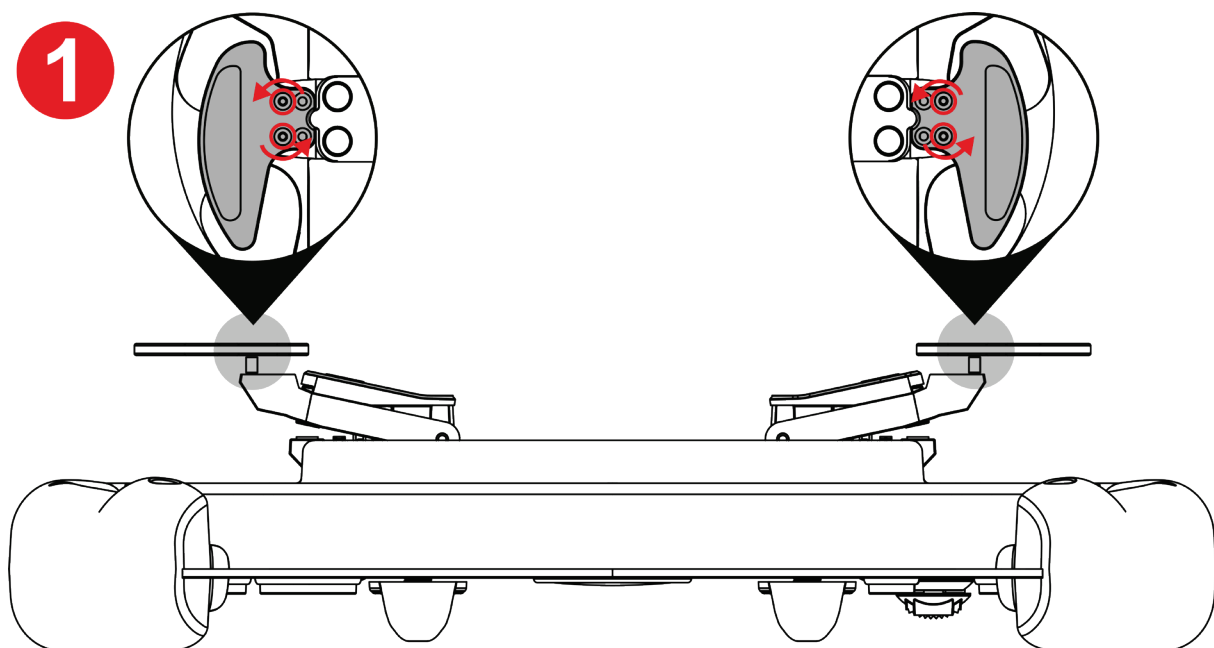

1 Svita le quattro viti delle leve del cambio utilizzando l'acclusa chiave Torx.

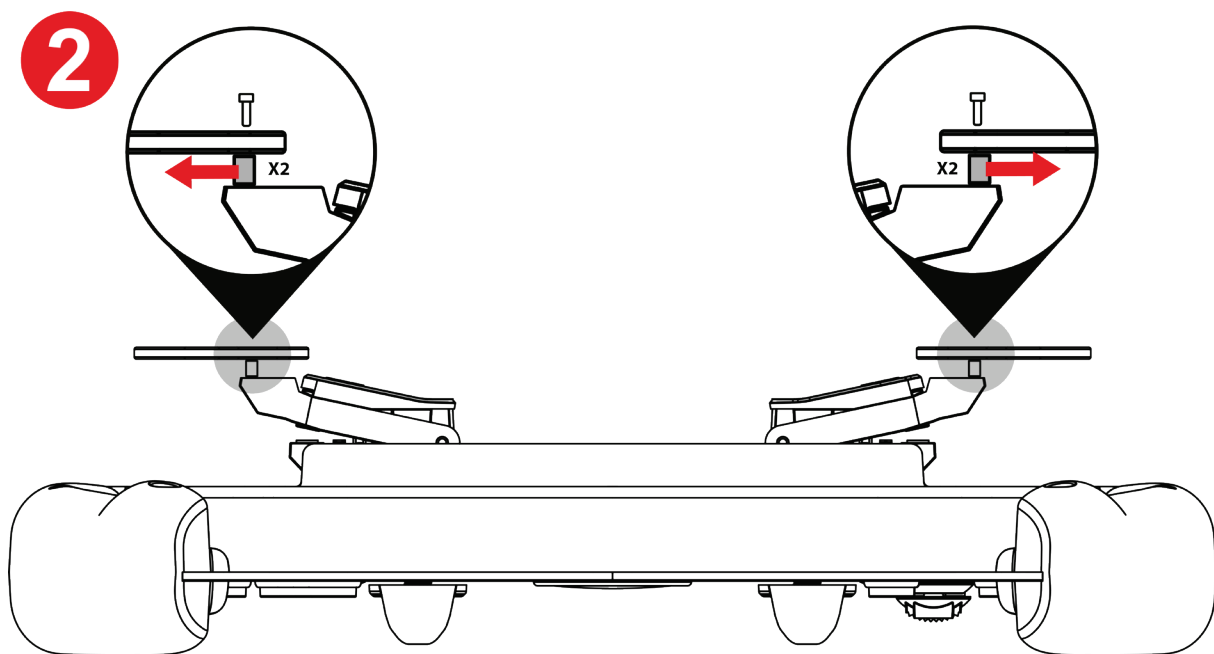

2 Rimuovi i distanziatori.

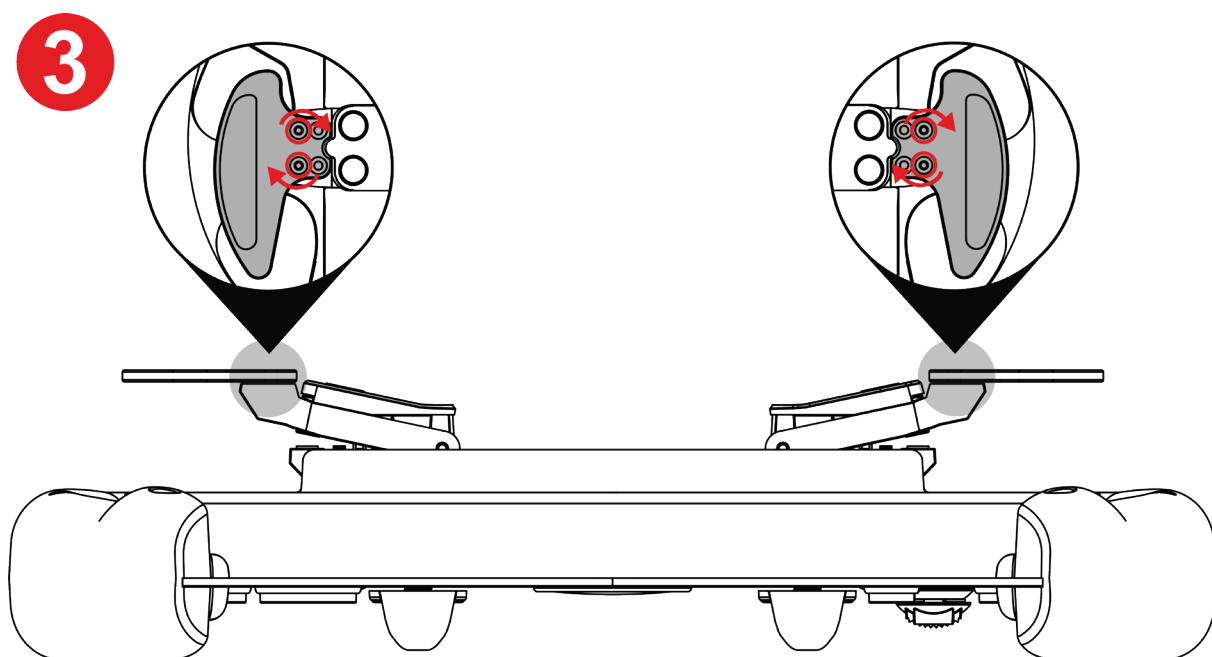

3 Stringi le quattro viti delle leve del cambio utilizzando l'acclusa chiave Torx.



Come regolare la sensibilità magnetica e il livello del suono delle leve del cambio

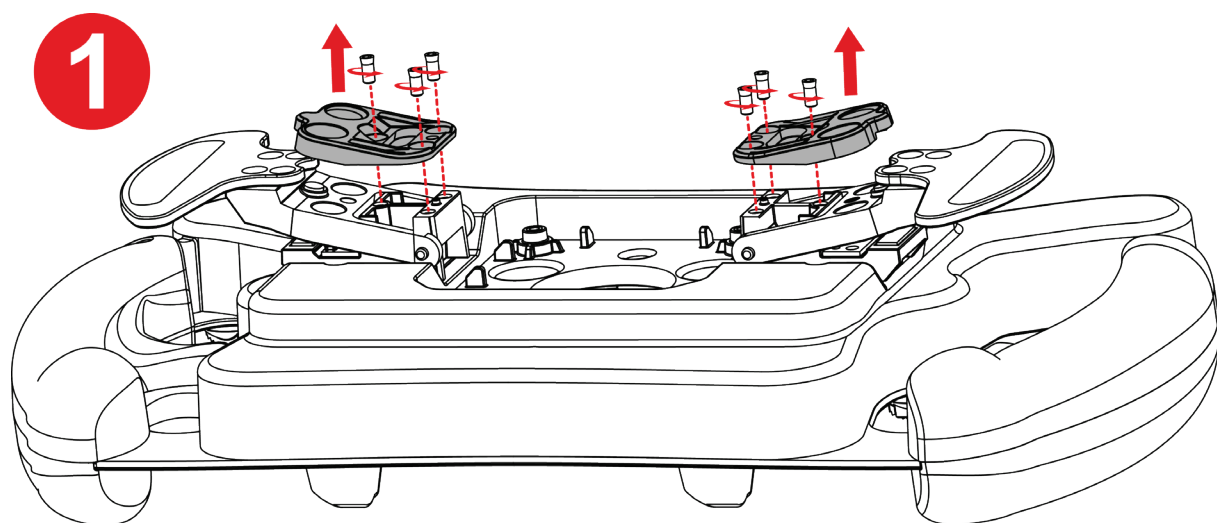

1 Rimuovi i fermi magnetici svitando le sei viti di arresto tramite l'acclusa chiave Torx.

2

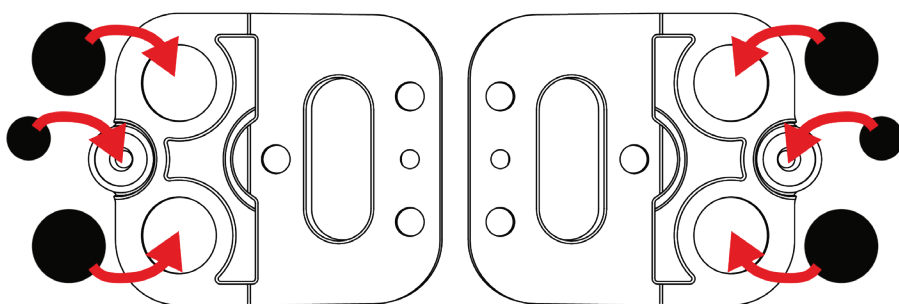
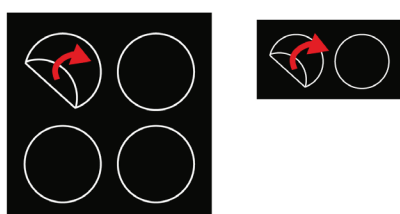

2 Stacca i cuscinetti in dotazione e attaccali negli appositi spazi sotto ai fermi magnetici.



Per le possibili configurazioni e i relativi effetti, consulta la **Tabella della sensibilità magnetica e dell'attenuazione del suono delle leve del cambio.**



3

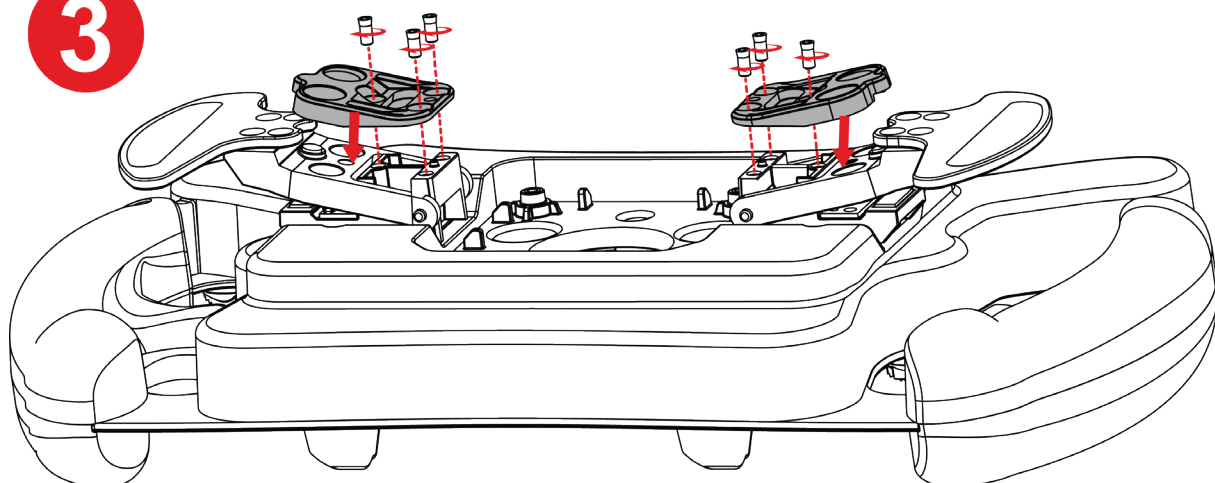

3 Reinstalla i fermi magnetici e stringi le sei viti di arresto tramite l'acclusa chiave Torx.

Tabella della sensibilità magnetica e dell'attenuazione del suono delle leve del cambio

	 (predefinita)		
Sensibilità magnetica			
Suono			



8. FAQ e assistenza tecnica

Hai delle domande riguardanti il Ferrari 488 GT3 Wheel Add-On o stai riscontrando dei problemi tecnici? Se così fosse, visita il sito web di assistenza tecnica Thrustmaster:

<https://support.thrustmaster.com/product/ferrarif488gt3addon>.

Tramite questa pagina, potrai anche aggiornare il firmware del volante.



THRUSTMASTER®

FERRARI 488 GT3 WHEEL ADD-ON

**PC (Windows 10/11)
PS4™ / PS5™
Xbox Series / Xbox One**

Manual del usuario



Lee atentamente las instrucciones proporcionadas en este manual **antes** de instalar el producto, **antes** de usar el producto y **antes** de realizar cualquier mantenimiento. Asegúrate de seguir las instrucciones de seguridad. El incumplimiento de estas instrucciones puede provocar accidentes y/o daños. Conserva este manual para poder consultar las instrucciones en el futuro.

TABLA DE CONTENIDO

1.	CONTENIDO DE LA CAJA	5
2.	CARACTERÍSTICAS	6
3.	INFORMACIÓN SOBRE EL USO DEL VOLANTE	8
4.	INSTALACIÓN DEL SOPORTE DE LIBERACIÓN RÁPIDA.....	13
	<i>Instalación del soporte de liberación rápida para base de pestillo</i>	<i>14</i>
	<i>Instalación del soporte de liberación rápida para base de tornillo</i>	<i>17</i>
5.	MAPEADO	21
	<i>Mapeado para PC</i>	<i>21</i>
	<i>Mapeado para PS4™/PS5™</i>	<i>22</i>
	<i>Mapeado para Xbox Series/Xbox One.....</i>	<i>23</i>
6.	FUNCIONAMIENTO DE LOS LED.....	24
	<i>Cómo entrar/salir del menú LED</i>	<i>25</i>
	<i>Cómo ajustar la intensidad de los LED....</i>	<i>27</i>

Cómo cambiar el modo LED: GT3 o

Formula28

7. PERSONALIZACIÓN DE LAS LEVAS DE CAMBIO.....29

Cómo ajustar el espaciado de las levas de cambio31

Cómo ajustar el alcance de las levas de cambio33

Cómo ajustar la sensibilidad magnética y el nivel sonoro de las levas de cambio....35

8. PREGUNTAS FRECUENTES Y SOPORTE TÉCNICO37



FERRARI 488 GT3 WHEEL ADD-ON

Forma parte de la leyenda de las carreras de GT con el Ferrari 488 GT3 Wheel Add-On, un volante diseñado pensando en el rendimiento, y compatible con todas las bases de volante de Thrustmaster.

Este manual te ayudará a instalar y usar el Ferrari 488 GT3 Wheel Add-On en las mejores condiciones. Antes de empezar a conducir, lee atentamente las instrucciones y las advertencias: te ayudarán a disfrutar al máximo de tu producto.



1. Contenido de la caja

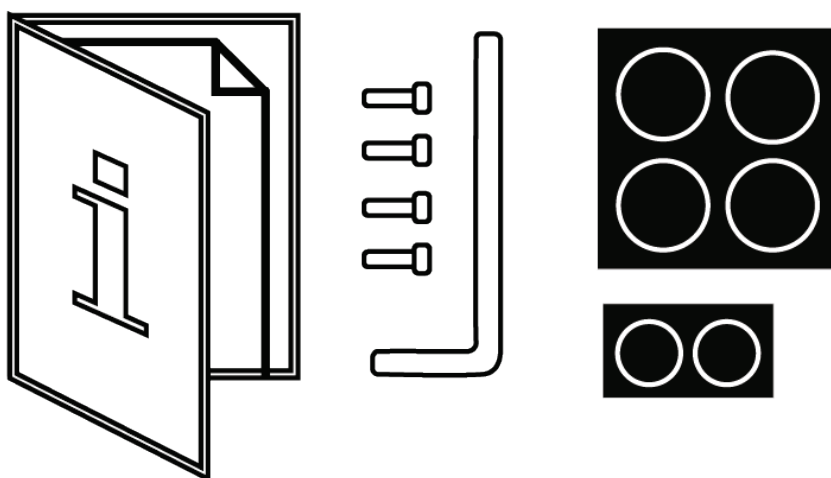
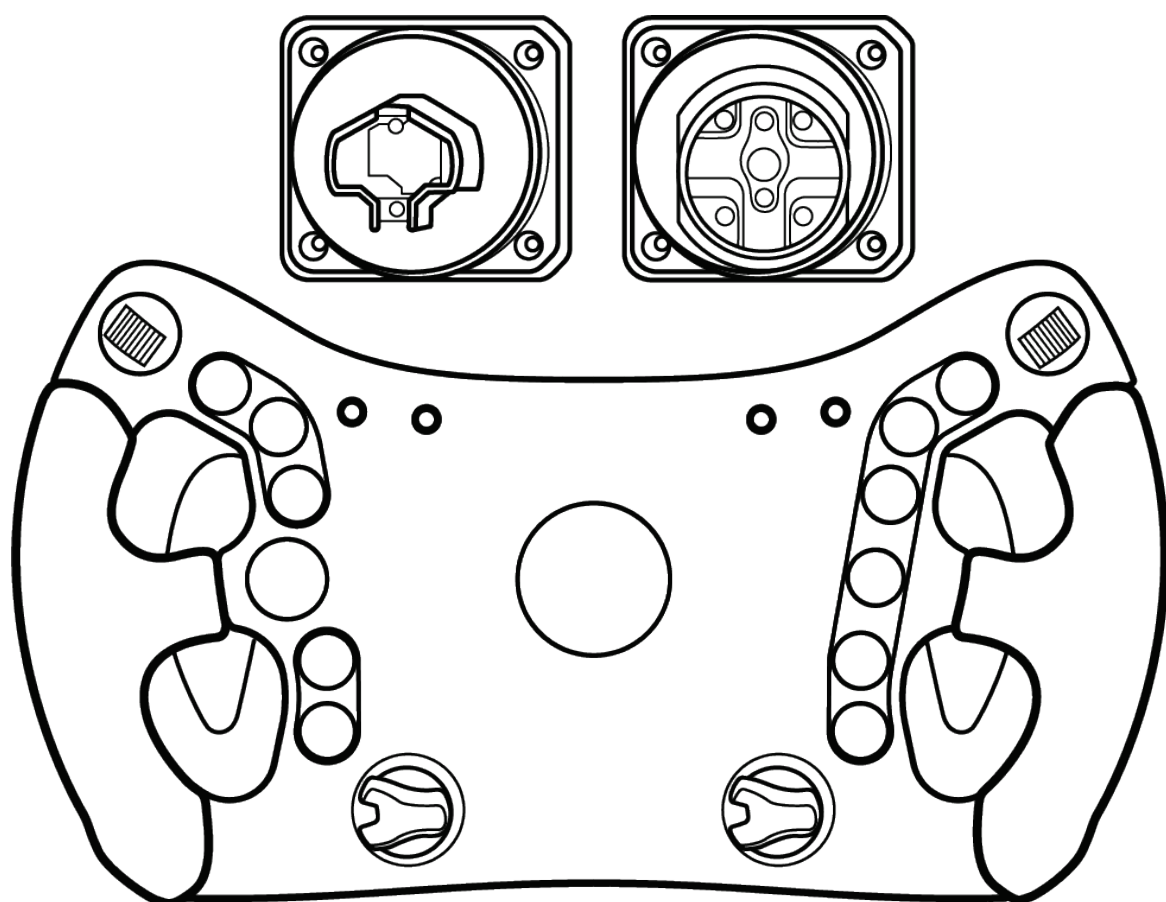



2. Características

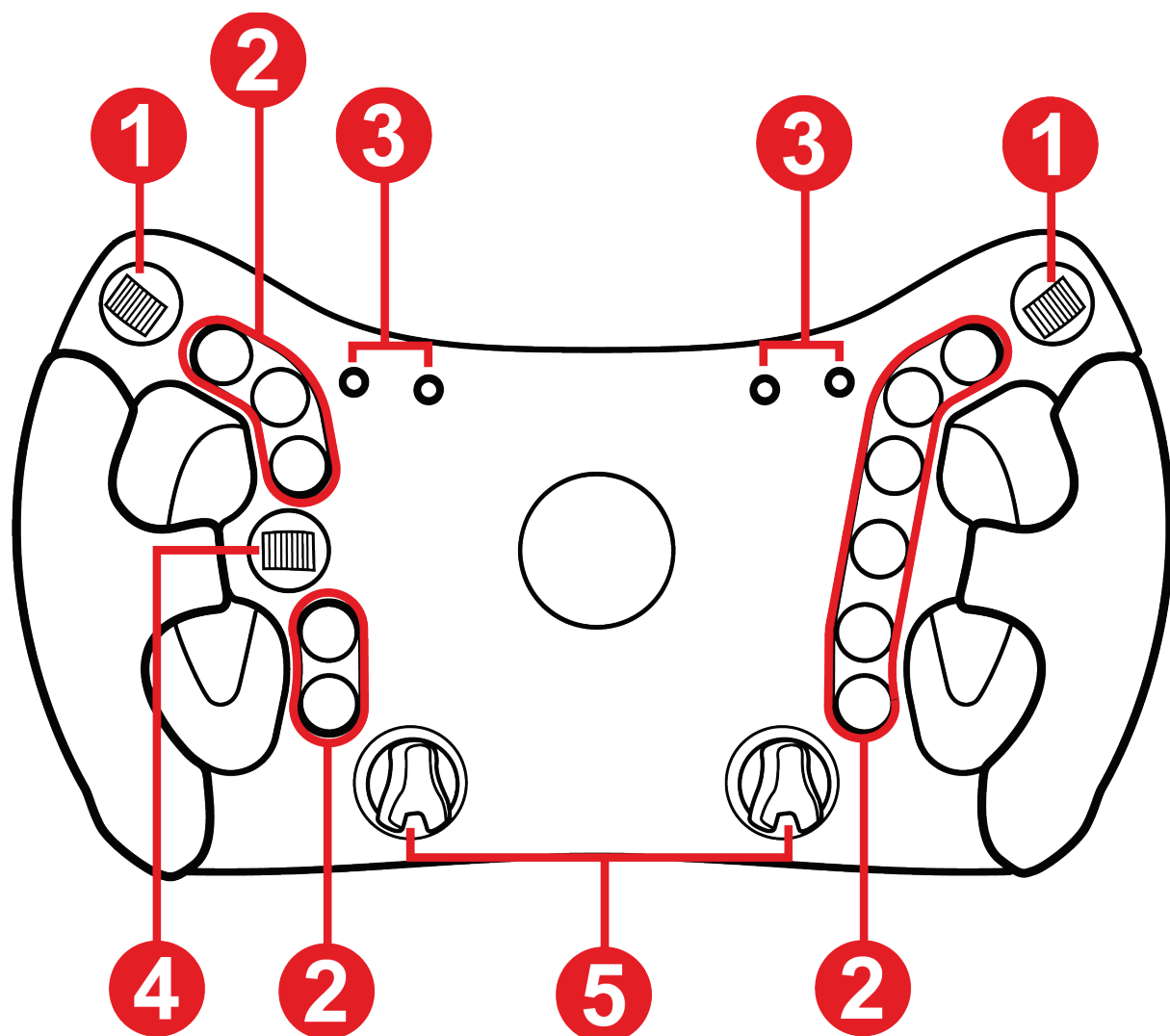

- ❶ Codificadores de pulgar
- ❷ 11 botones de acción
- ❸ LED de RPM y datos de carrera (banderas, boxes)
- ❹ D-pad
- ❺ Codificadores giratorios

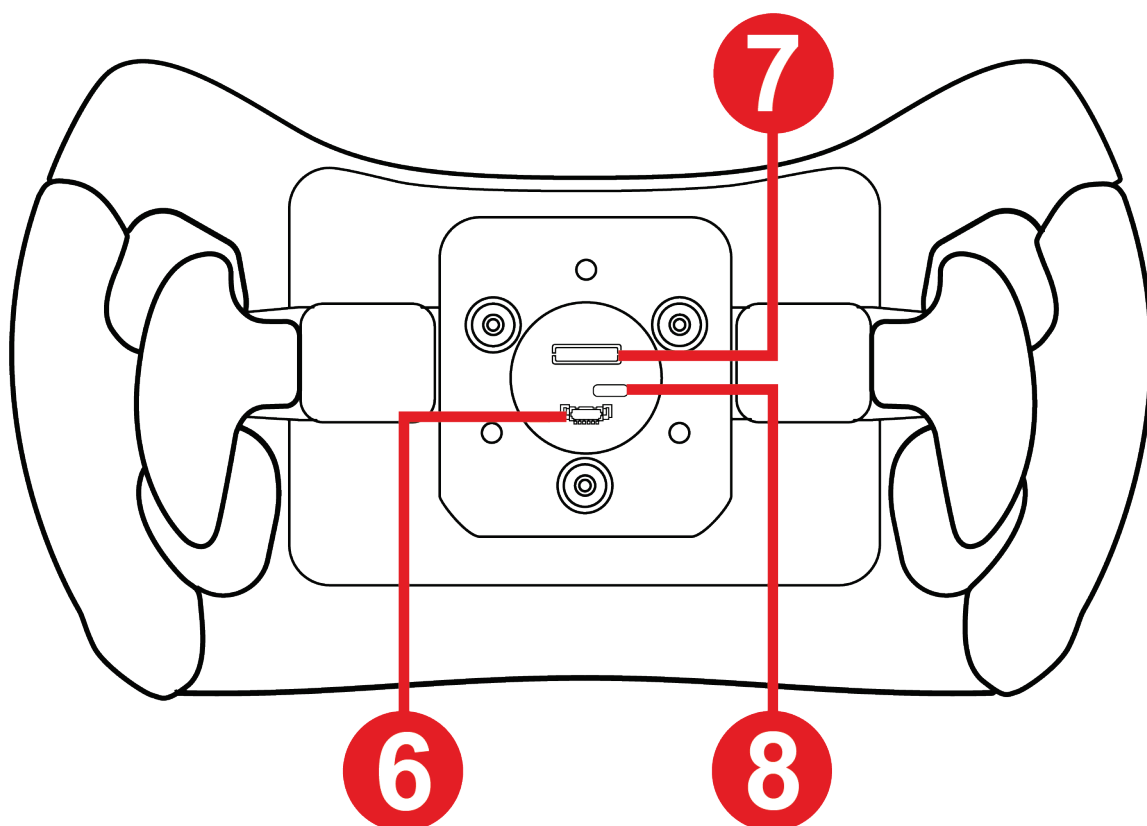

⑥ Puerto de conexión para soporte de liberación rápida para base de tornillo

⑦ Puerto de conexión para soporte de liberación rápida para base de pestillo

⑧ Puerto USB-C (si se requiere una actualización de firmware; cable no incluido)

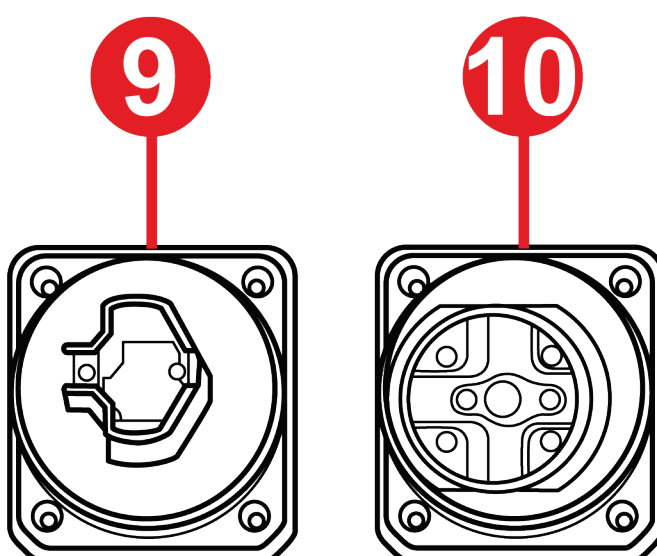

⑨ Soporte de liberación rápida para base de pestillo

⑩ Soporte de liberación rápida para base de tornillo



3. Información sobre el uso del volante



Documentación

Antes de usar este producto, vuelve a leer atentamente esta documentación y guárdala para consultarla en el futuro.



Descarga eléctrica

- Mantén el producto en un lugar seco y no lo expongas al polvo ni a la luz solar.
- No retuerzas ni tires de los conectores y cables.
- Sigue las indicaciones de conexión.
- No derrames ningún líquido sobre el producto o sus conectores.
- No cortocircuites el producto.
- No desmontes nunca el producto (excepto en los casos de personalización especificados en este manual); no lo lances al fuego y no lo expongas a altas temperaturas.
- No abras el dispositivo: no hay piezas reparables por el usuario en el interior. Cualquier reparación debe ser realizada por el fabricante, una agencia especificada o un técnico cualificado.



Asegurar la zona de juego

- No coloques en la zona de juego ningún objeto que pueda entorpecer la práctica del usuario, o que pueda provocar un movimiento inapropiado o una interrupción por parte de otra persona (por ejemplo, taza de café, teléfono o llaves).
- No cubras los cables de alimentación con una alfombra o moqueta, manta o cobertor o cualquier otro elemento, y no coloques ningún cable por donde vayan a pasar personas.



Lesiones por Force Feedback y movimientos repetidos

El uso de un volante de carreras Force Feedback puede causar dolor muscular o articular. Para evitar problemas:

- Calienta previamente y evita períodos prolongados de práctica.
- Haz un descanso de 10 a 15 minutos después de cada hora de práctica.
- Si sientes fatiga o dolor en las manos, muñecas, brazos, pies o piernas, pulsa el botón para desactivar el Force Feedback, apaga la base y descansa unas horas antes de comenzar a practicar nuevamente.
- Si los síntomas o dolores antes indicados persisten al volver a practicar, deja de hacerlo y consulta a tu médico.
- No configures el Force Feedback a un nivel demasiado alto en relación con tu experiencia y tu condición física.
- Mantén el dispositivo fuera del alcance de personas menores de 16 años.
- Asegúrate de que la base y el volante estén correctamente fijados, según las instrucciones del manual.



Riesgo de giros imprevistos, potentes y rápidos: no introduzcas nunca una mano o un brazo a través de las aberturas del volante, o en la trayectoria de giro del volante.

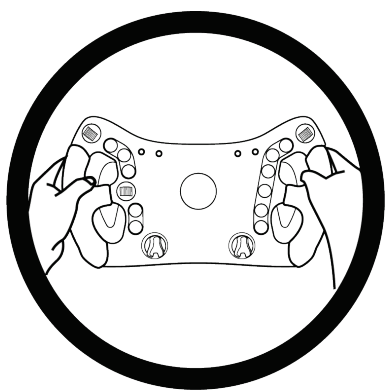

Cuando uses el producto, mantén siempre ambas manos correctamente colocadas sobre el volante sin soltarlo nunca por completo.



Producto para ser manipulado únicamente por personas **mayores de 16 años.**



4. Instalación del soporte de liberación rápida

El **Ferrari 488 GT3 Wheel Add-On** incluye dos soportes de liberación rápida correspondientes a los formatos básicos de Thrustmaster.

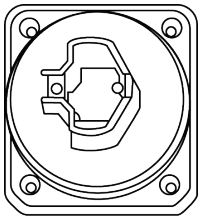
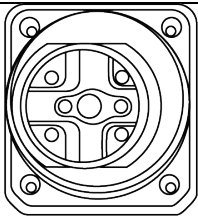
Sistema	Compatibilidad
 <p>Soporte de liberación rápida para base de pestillo</p>	T818, T818 Ferrari SF1000 Simulator y futuras bases de Thrustmaster.
 <p>Soporte de liberación rápida para base de tornillo</p>	T-GT / T-GT II Servo Base, T300 RS Servo Base, TS PC Racer, TS-XW, TX Racing Wheel Servo Base, TS-XW Servo Base.



Antes de cada uso, verifica que el **Ferrari 488 GT3 Wheel Add-On** todavía esté correctamente sujeto al soporte, según las instrucciones del manual de la base.



Instalación del soporte de liberación rápida para base de pestillo

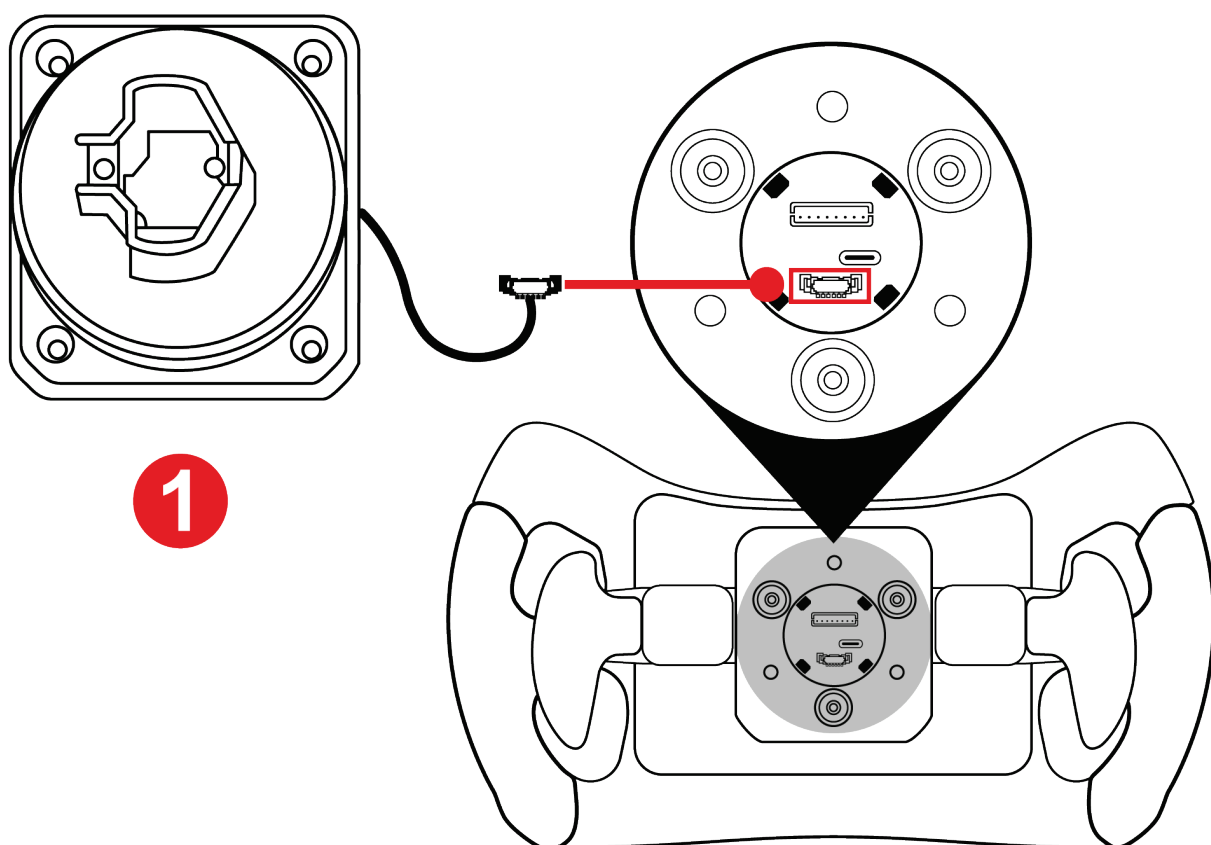

1 Inserta el conector del soporte de liberación rápida en el puerto apropiado en la parte posterior del volante.



Para evitar pellizcar el cable, retíralo dentro de su alojamiento antes de atornillar el soporte.

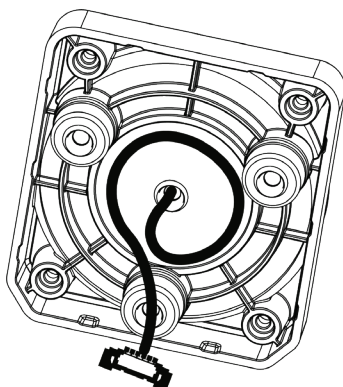

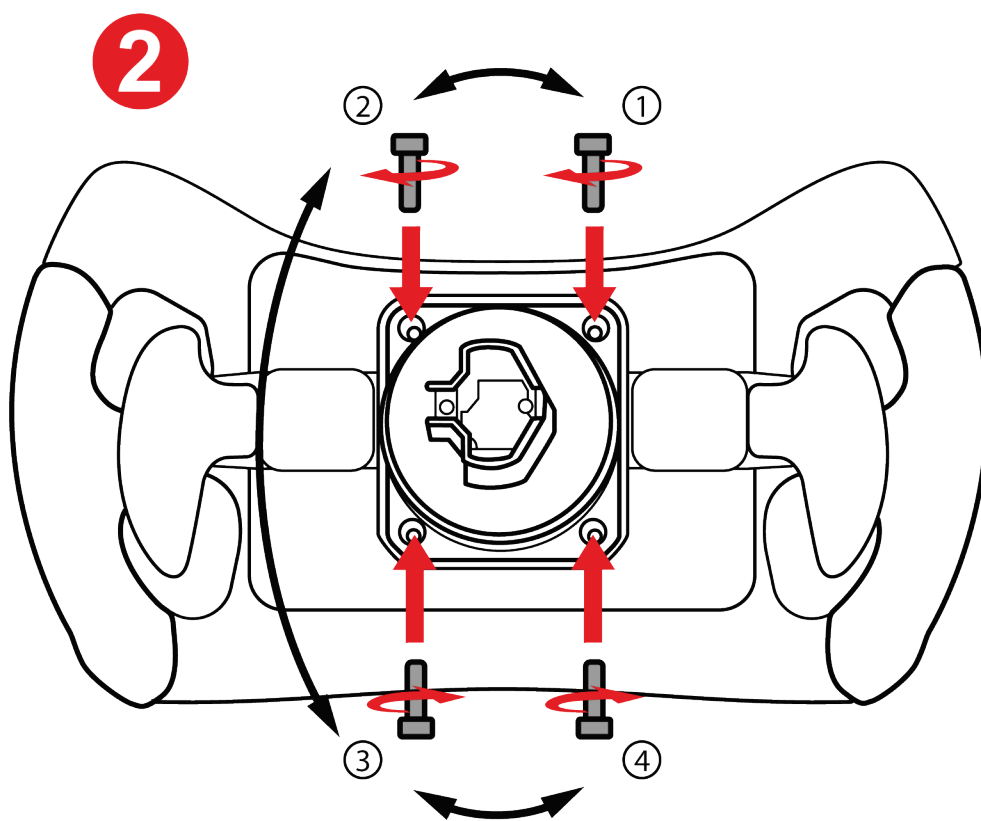

2 Inserta el soporte de liberación rápida y apriétalo con la llave Torx suministrada.



Al montar el soporte, no aprietes demasiado los tornillos.

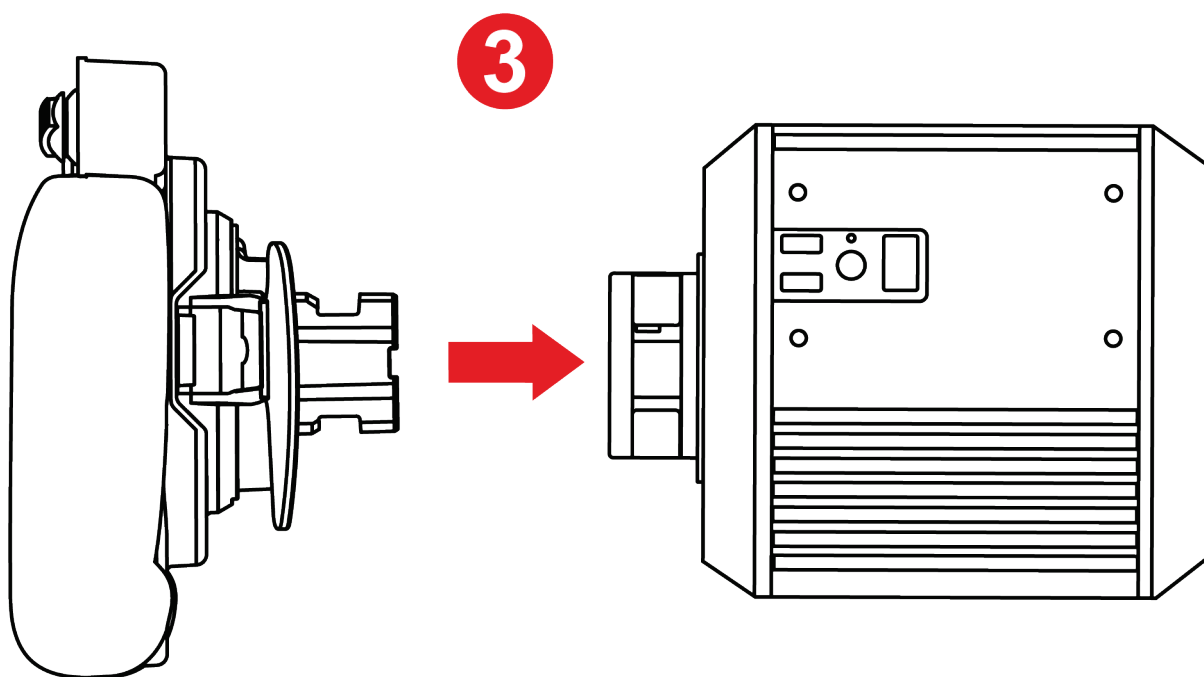

3 Monta el volante en la base.



Sigue el procedimiento de instalación especificado en el manual de usuario de la base.



Instalación del soporte de liberación rápida para base de tornillo

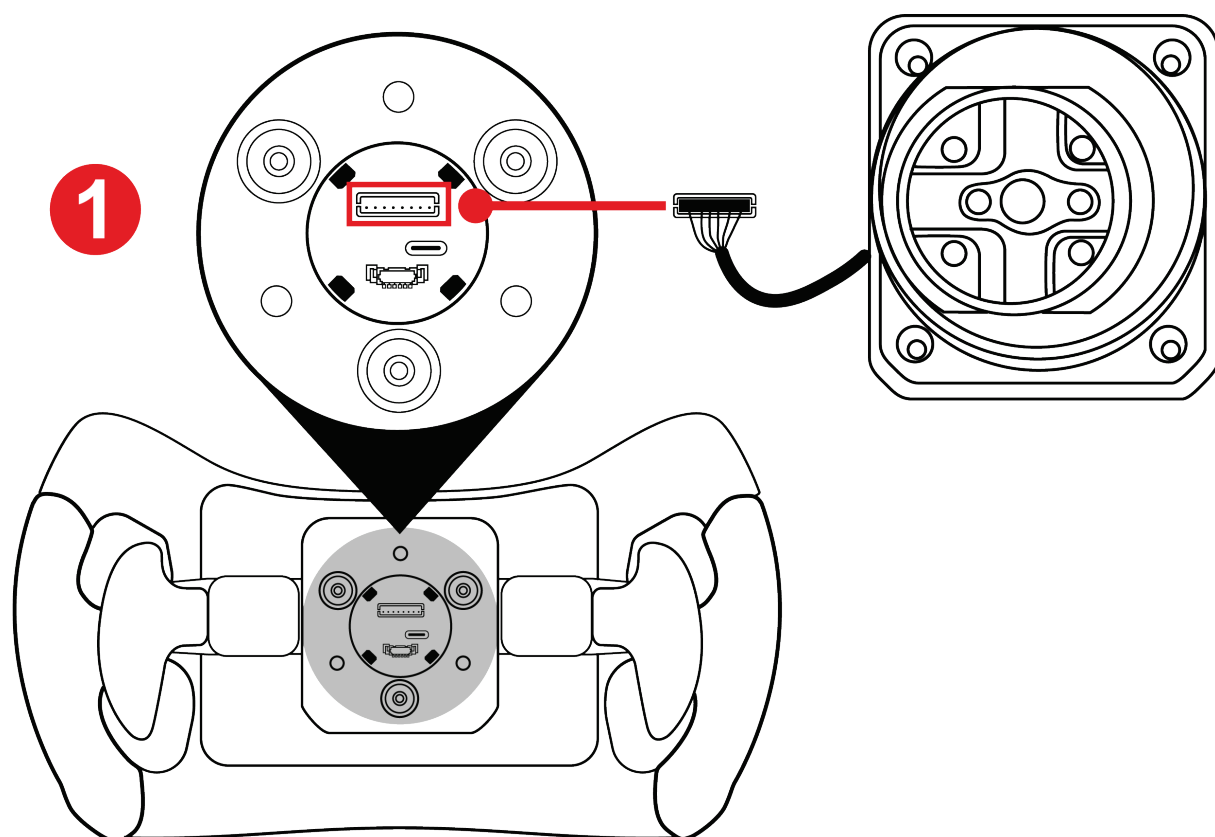

1 Inserta el conector del soporte de liberación rápida en el puerto apropiado en la parte posterior del volante.



Para evitar pellizcar el cable, retíralo dentro de su alojamiento antes de atornillar el soporte.

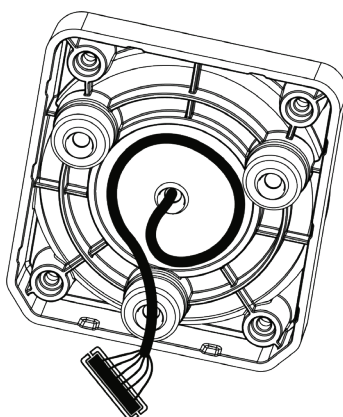

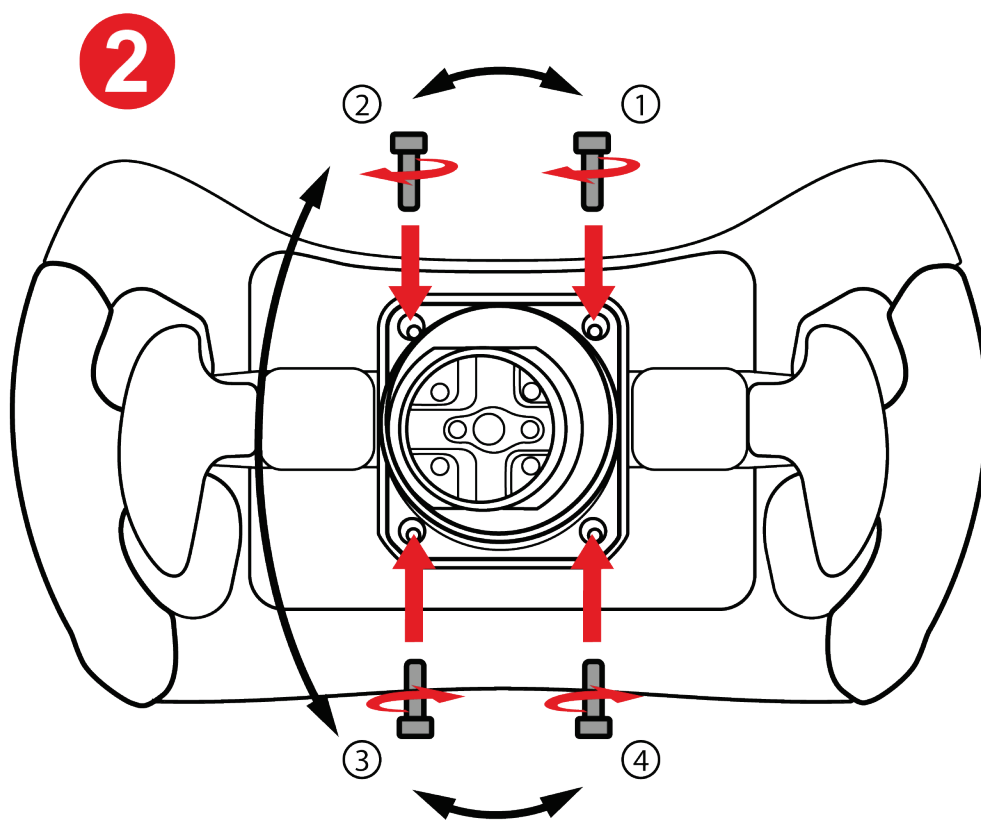

2 Inserta el soporte de liberación rápida y apriétalo con la llave Torx suministrada.



Al montar el soporte, no aprietes demasiado los tornillos.

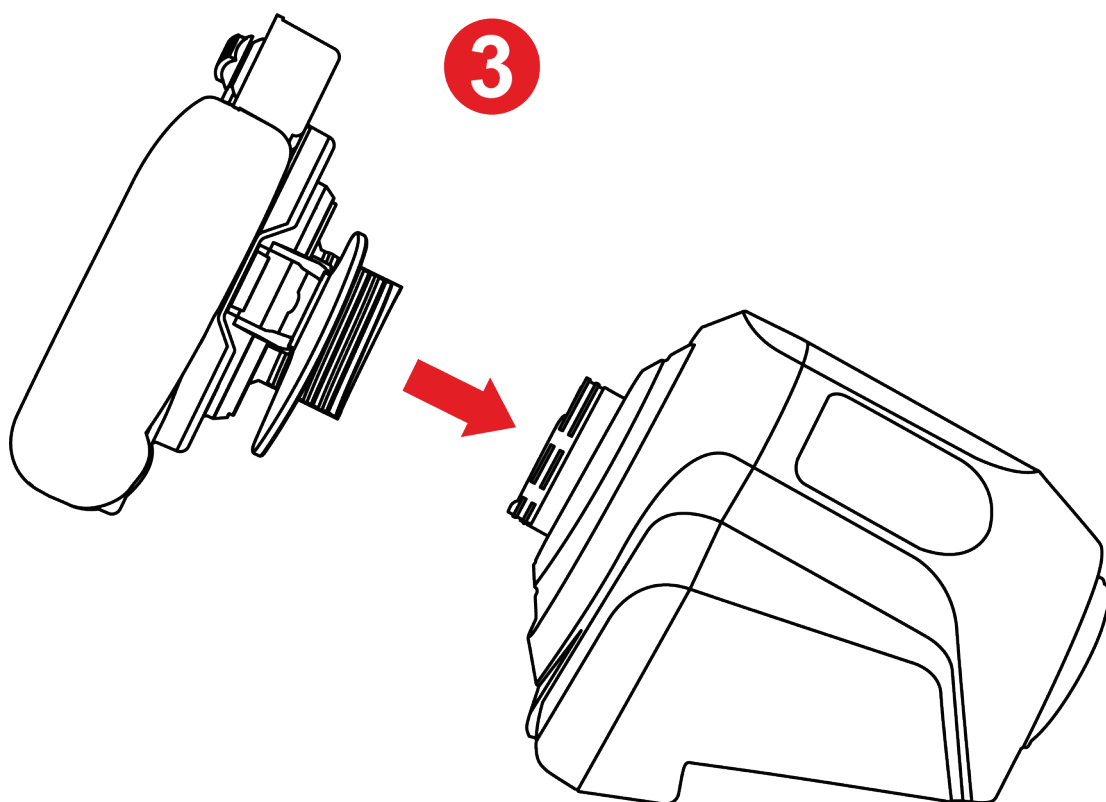

3 Monta el volante en la base.



Sigue el procedimiento de instalación especificado en el manual de usuario de la base.



No conectes nunca el adaptador de liberación rápida (suministrado con la base T818 y vendido por separado) al soporte de liberación rápida para base de tornillo si tienes intención de usarlo en una base T818.

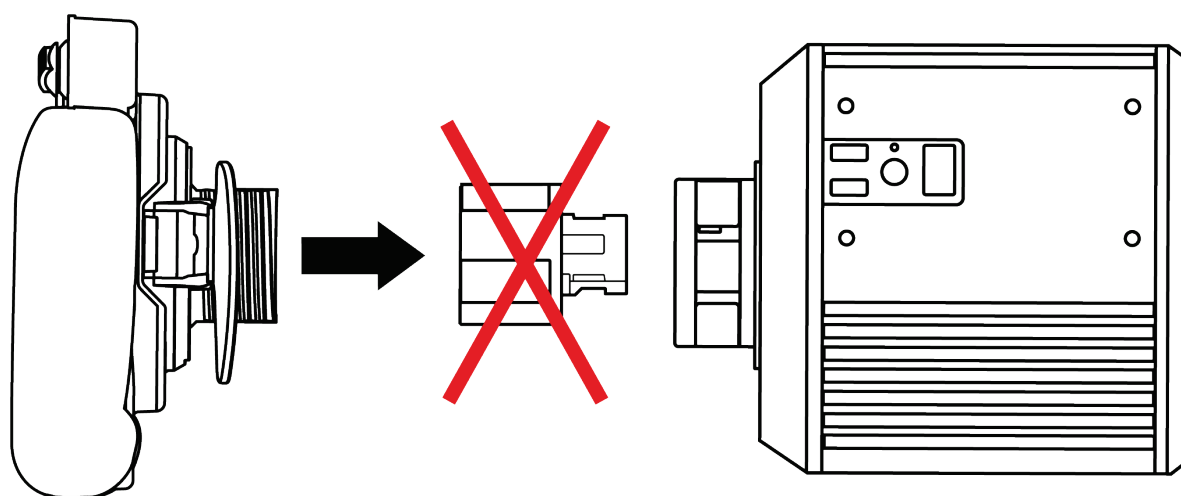
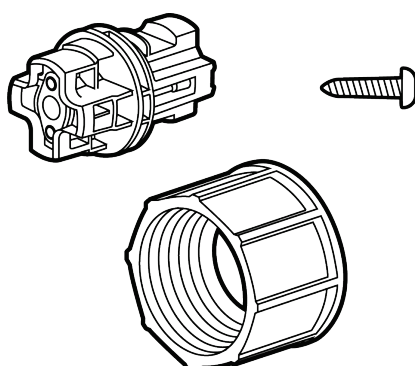

Para usarlo en una base T818 o una base equipada con un conector para base de pestillo, usa sólo el **soporte de liberación rápida para base de pestillo** suministrado con el **Ferrari 488 GT3 Wheel Add-On**.



5. Mapeado

Mapeado para PC

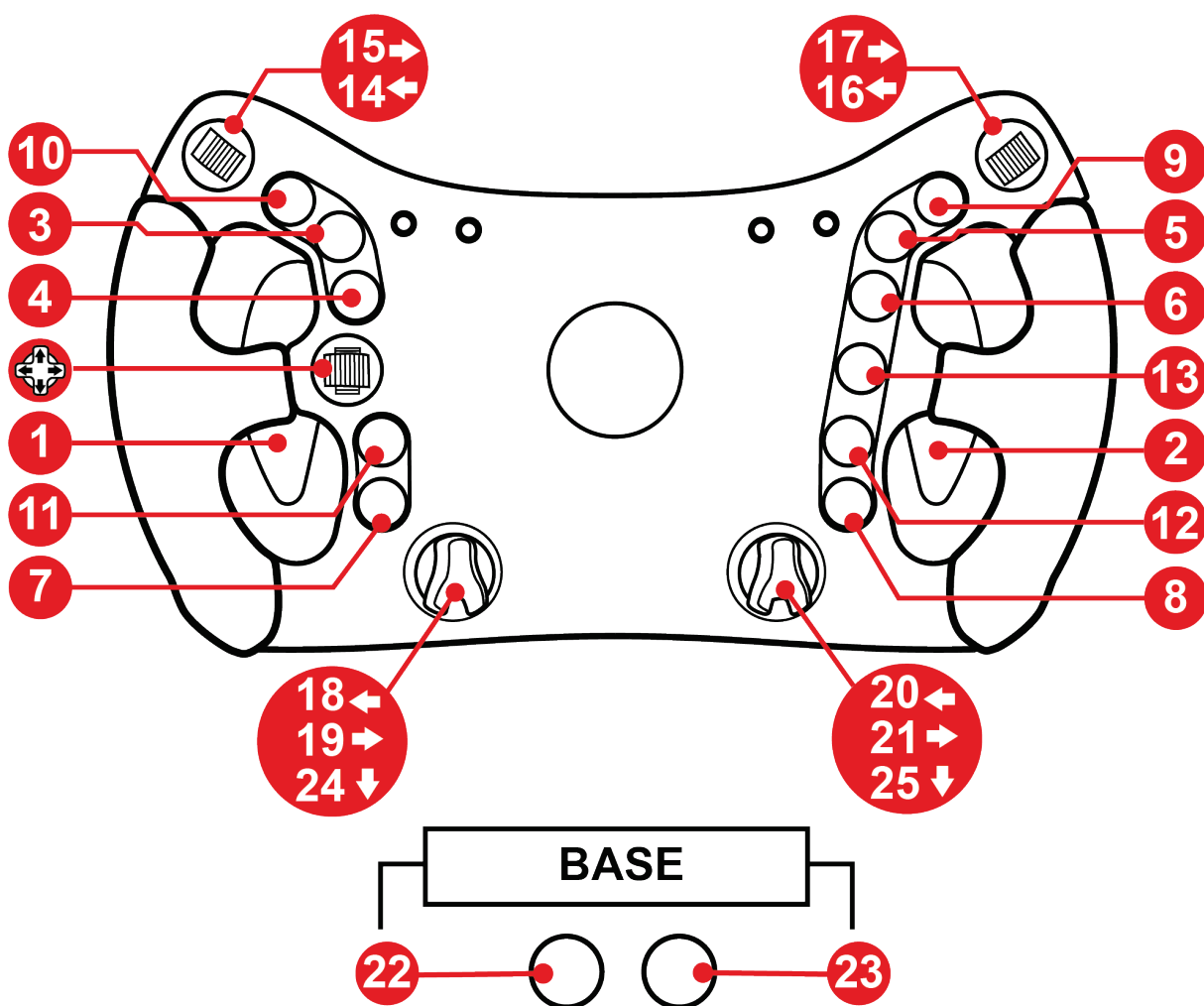



Mapeado para PS4™/PS5™

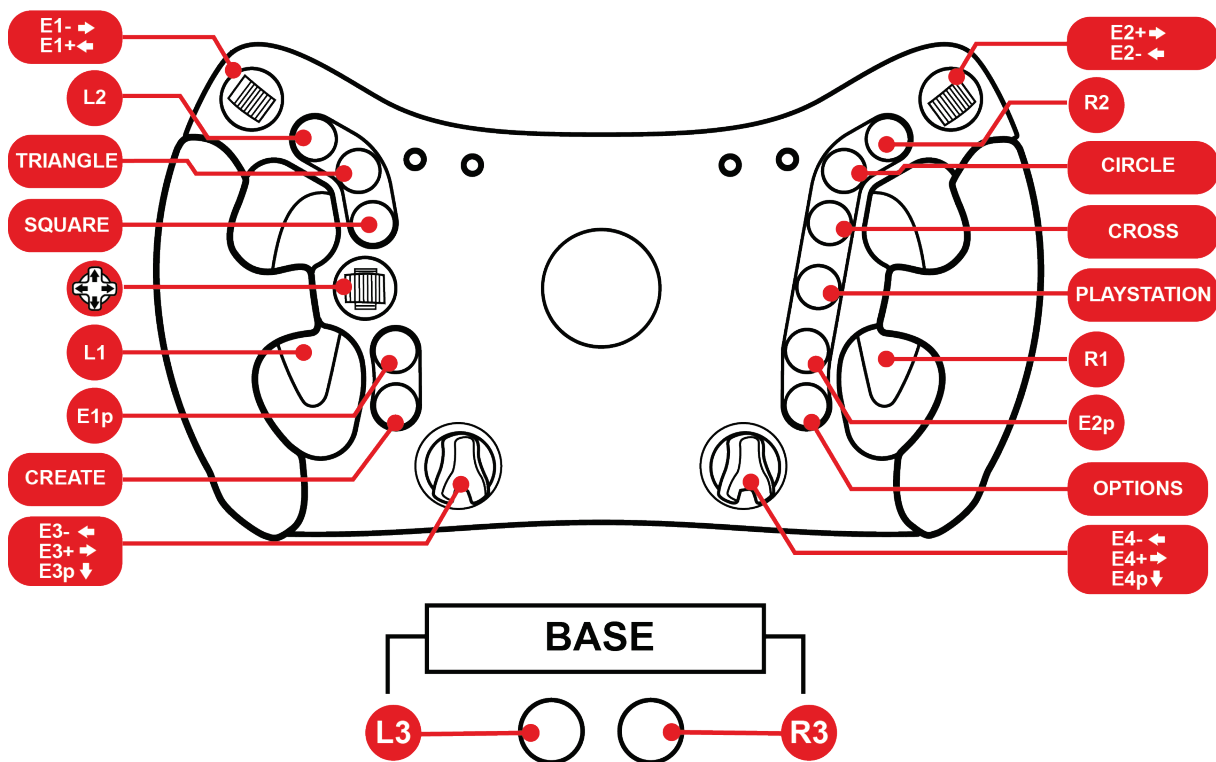



Mapeado para Xbox Series/Xbox One

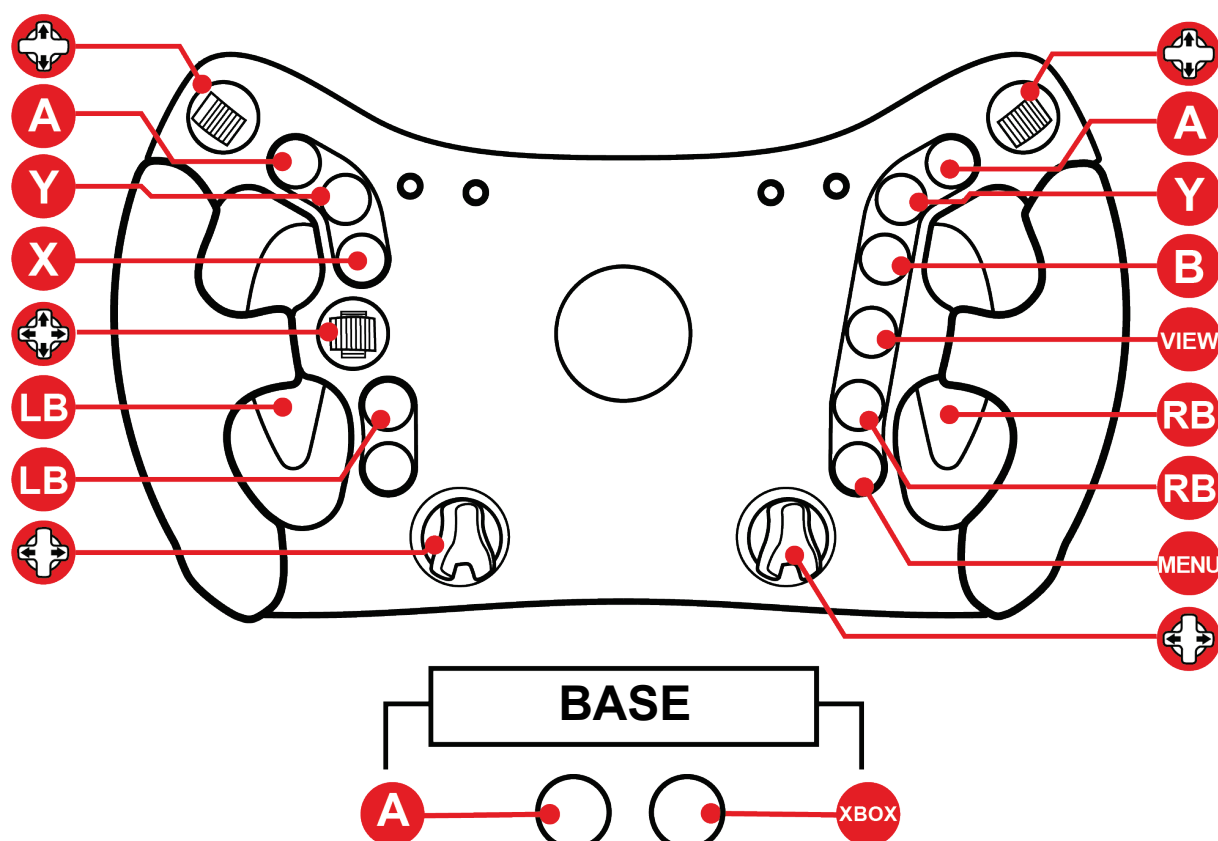

En Xbox Series y Xbox One:

- Los LED del Ferrari 488 GT3 Wheel Add-On no funcionan debido a restricciones del protocolo de la consola.
- Algunas funciones (codificadores, número de botones) están limitadas por el protocolo de la consola.



6. Funcionamiento de los LED

El **Ferrari 488 GT3 Wheel Add-On** muestra los datos de la carrera a través de los LED: bandera, boxes y RPM. Los datos mostrados se pueden personalizar (intensidad y color de los LED de las RPM), según el modo (GT3 o Formula).

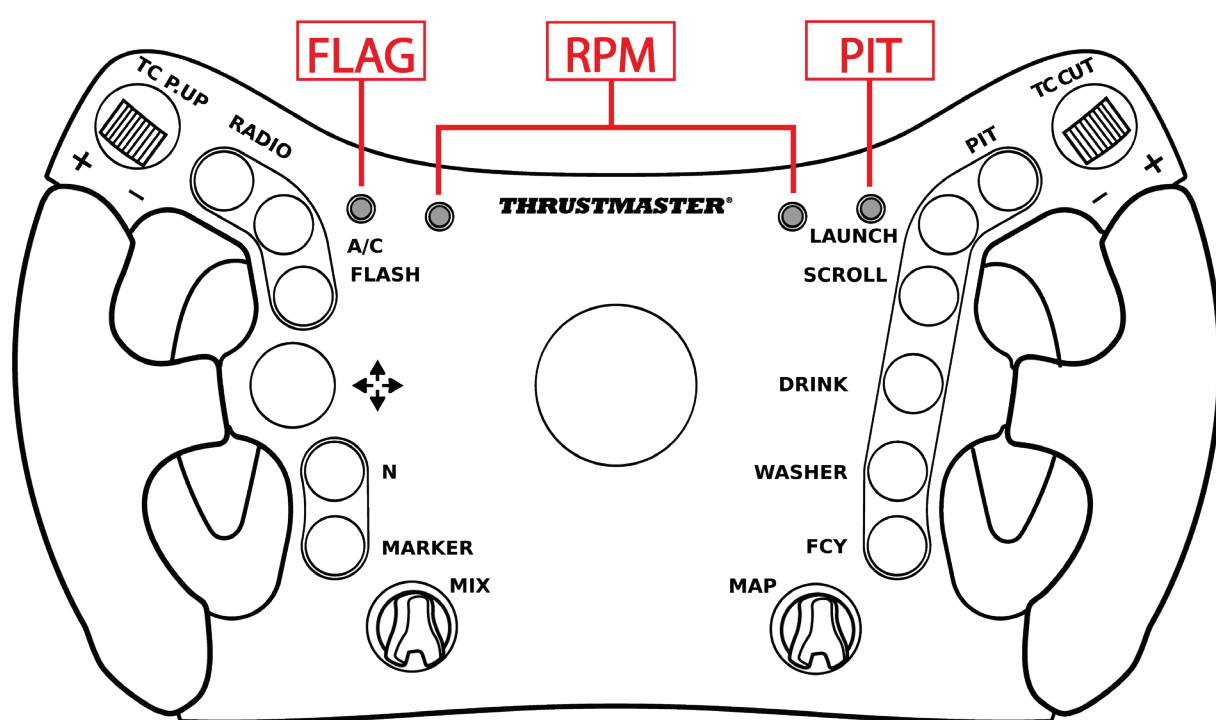

Los LED funcionan en PC y PS4™/PS5™.

En Xbox Series y Xbox One, los LED no funcionan debido a restricciones del protocolo de la consola.



Cómo entrar/salir del menú LED

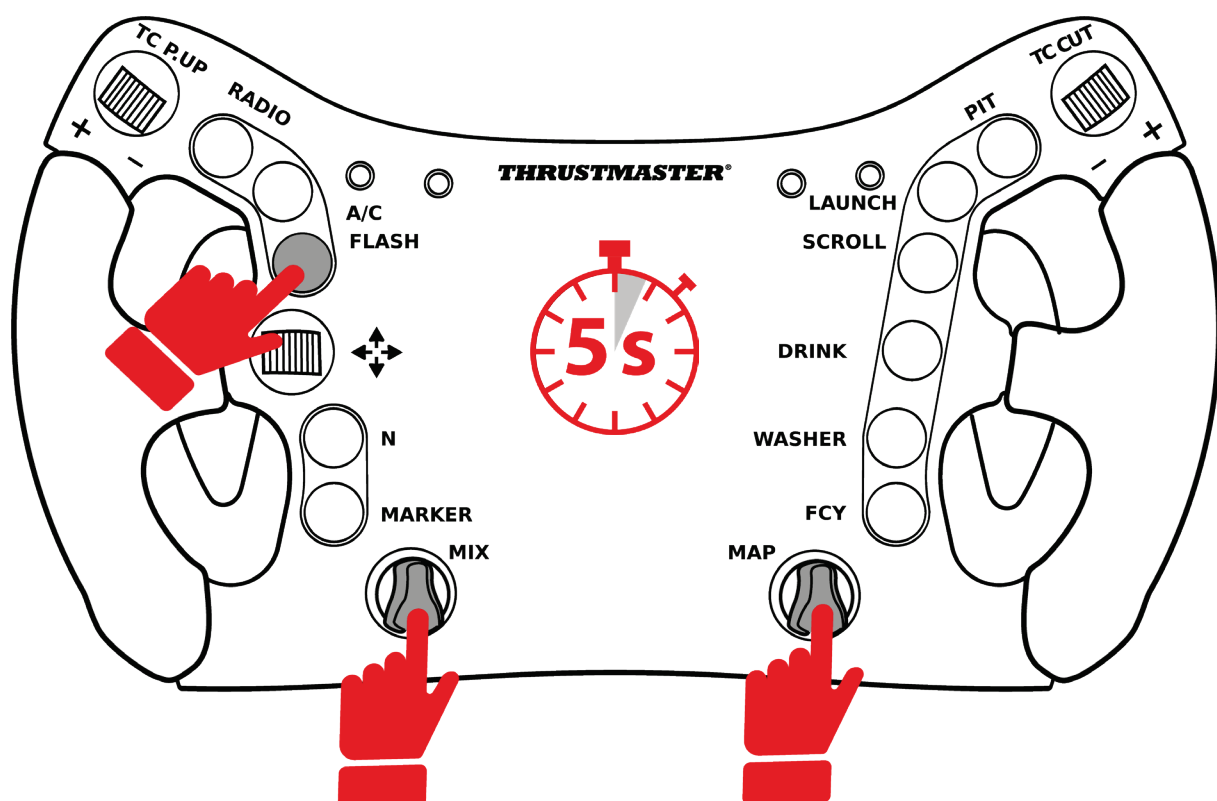

- Para entrar en el menú LED, pulsa simultáneamente el botón **FLASH** y ambos **codificadores giratorios durante 5 segundos**, y luego suéltalos.

- Para salir del menú LED, pulsa simultáneamente el botón **FLASH** y ambos **codificadores giratorios**, y luego suéltalos.



FLAG

RPM

PIT



Entrar en el menú LED: se encienden los LED FLAG y PIT y uno de los LED de RPM (rojo a la izquierda o azul a la derecha).



Salir del menú LED: se apagan los cuatro LED.



Cómo ajustar la intensidad de los LED

- Entra en el menú LED pulsando simultáneamente el botón **FLASH** y ambos **codificadores giratorios** durante 5 segundos, y luego suéltalos.
- Gira el **codificador izquierdo (MIX)** hacia la izquierda para disminuir la intensidad, o hacia la derecha para aumentarla.



- Sal del menú LED pulsando simultáneamente el botón **FLASH** y ambos **codificadores giratorios**, y luego suéltalos.



Cómo cambiar el modo LED: GT3 o Formula

- Entra en el menú LED pulsando simultáneamente el botón **FLASH** y ambos **codificadores giratorios durante 5 segundos**, y luego suéltalos.
- Gira el **codificador derecho (MAP)** hacia la izquierda para seleccionar el modo GT3 (LED rojo), o hacia la derecha para seleccionar el modo Formula (LED azul).



Modo GT3 (modo predeterminado)



Modo FORMULA

- Sal del menú LED pulsando simultáneamente el botón **FLASH** y ambos **codificadores giratorios**, y luego suéltalos.



7. Personalización de las levas de cambio

Las levas de cambio del **Ferrari 488 GT3 Wheel Add-On** son ajustables en **espaciado** y **alcance**.

El **espaciado** consiste en ajustar la leva de cambio en anchura, lo que modifica la distancia entre la empuñadura y la leva de cambio.

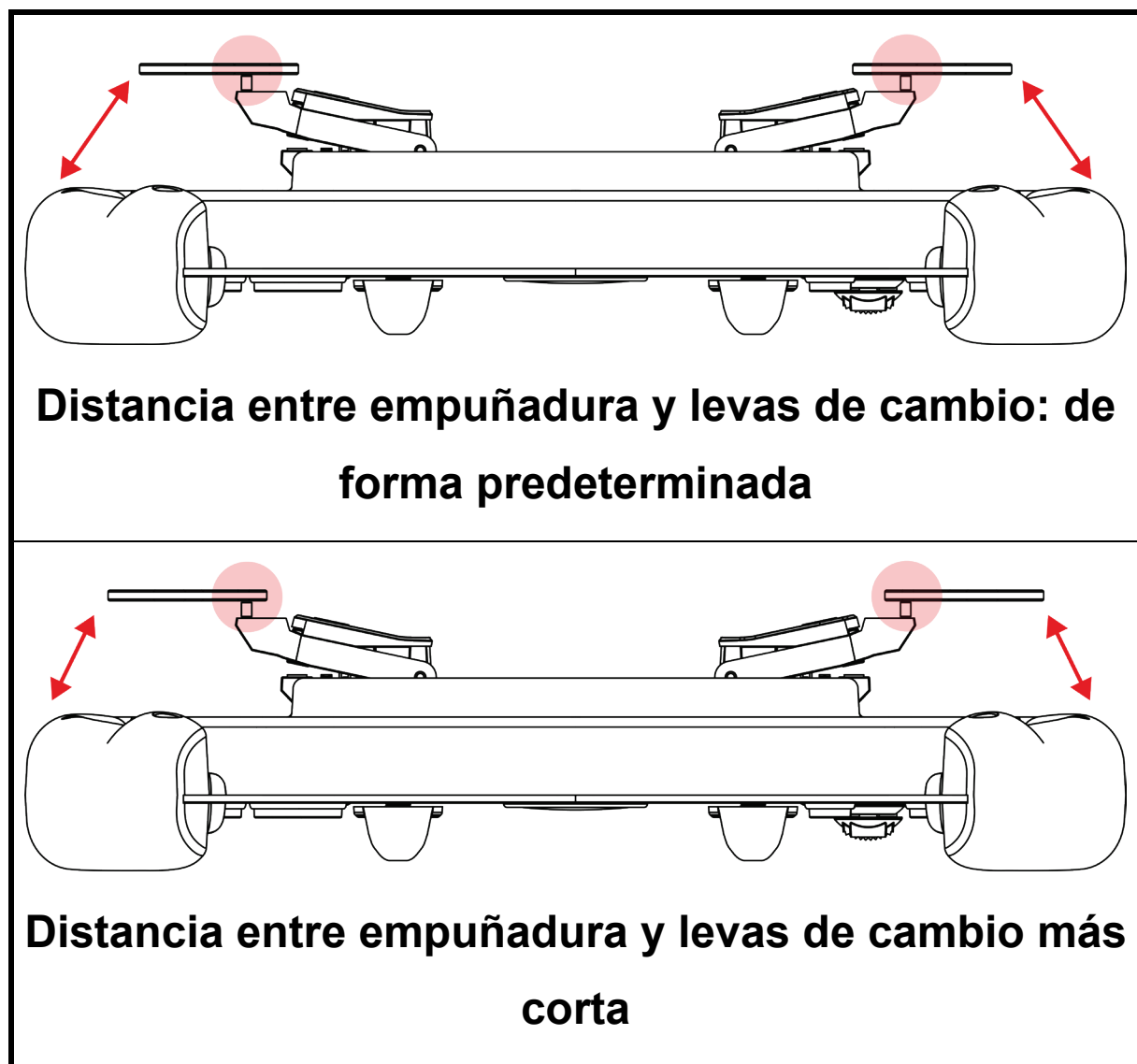



Ajustar el **alcance** mediante los espaciadores modifica la distancia de activación de las levas de cambio.

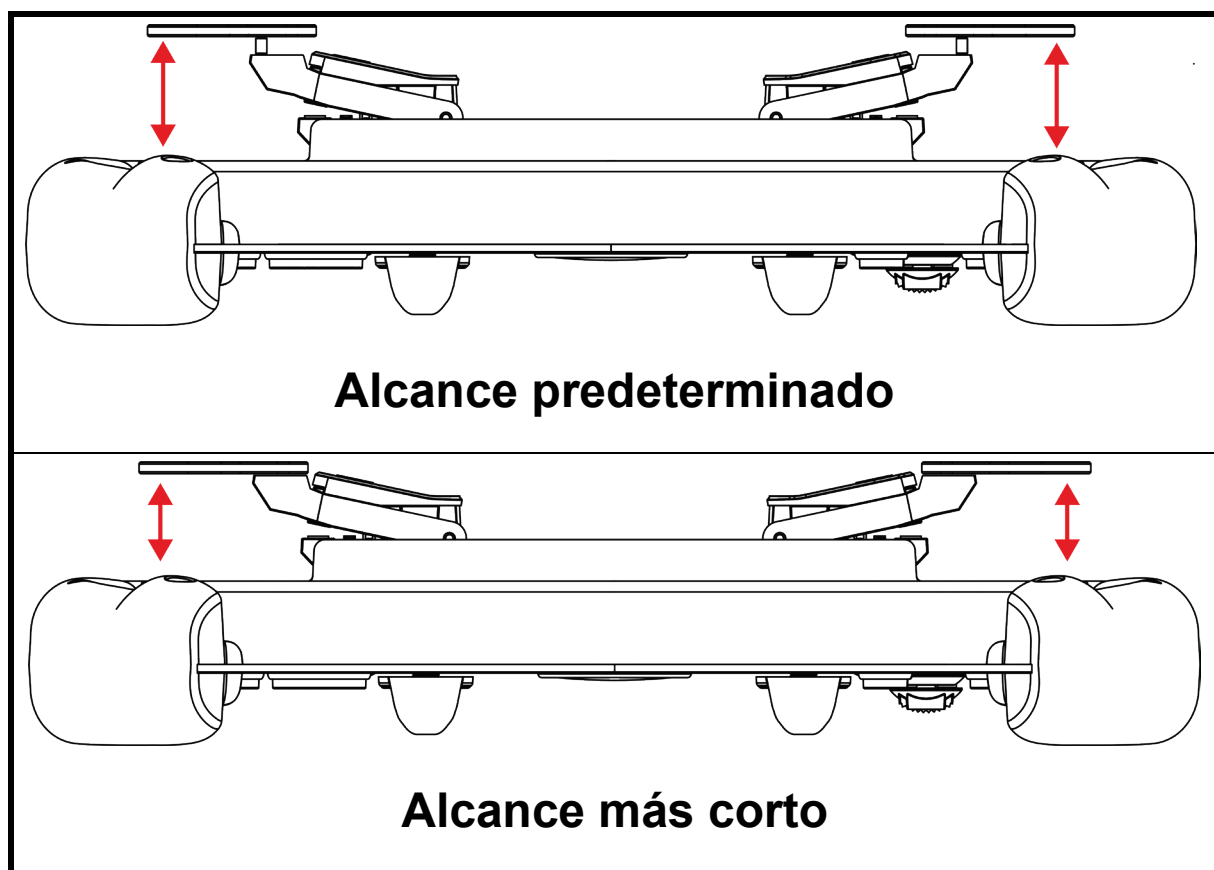

También es posible ajustar la **sensibilidad magnética** y el **nivel sonoro** producido por las levas de cambio, usando el juego de almohadillas suministrado.

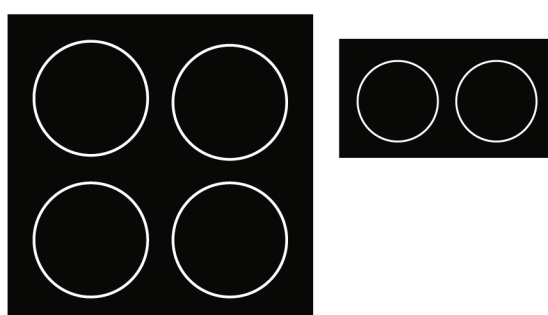



Cómo ajustar el espaciado de las levas de cambio de cambio

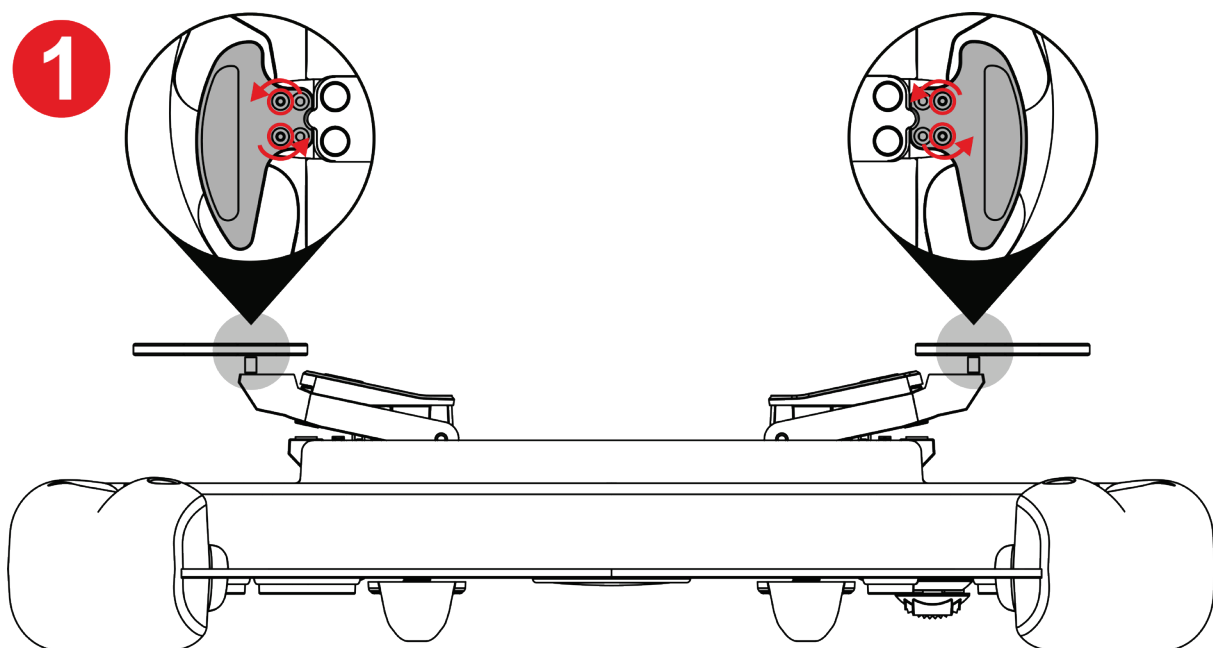

1 Afloja los cuatro tornillos de las levas de cambio con la llave Torx suministrada.

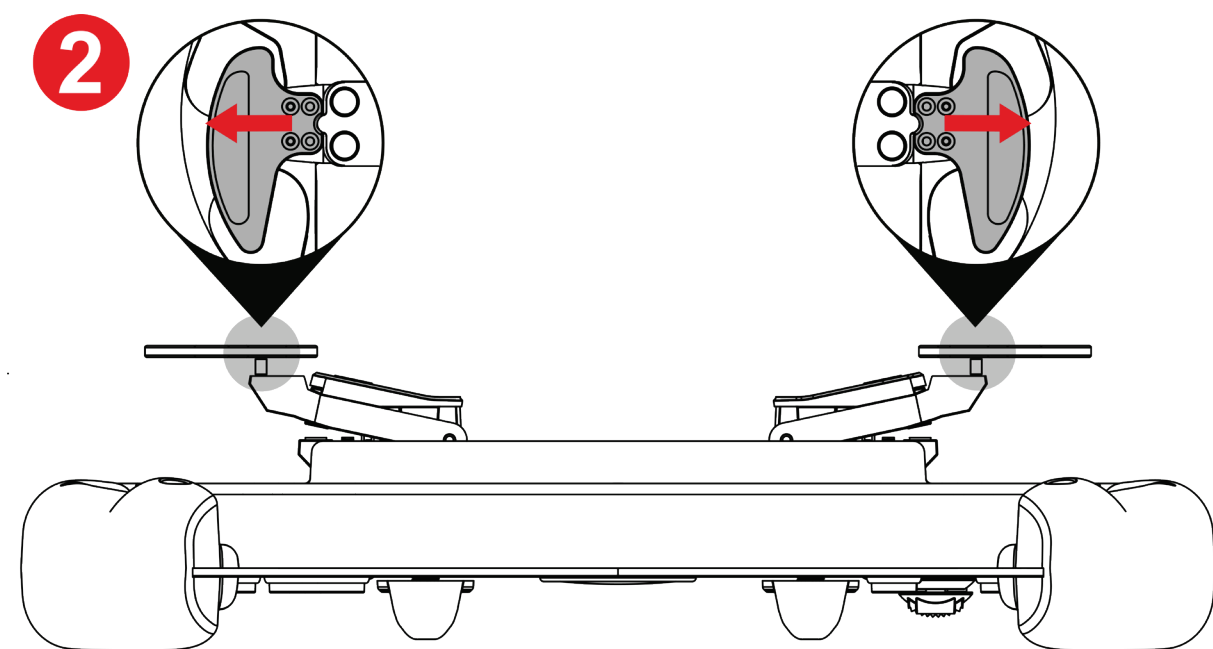

2 Mueve las levas de cambio hacia fuera para que coincidan con los orificios.

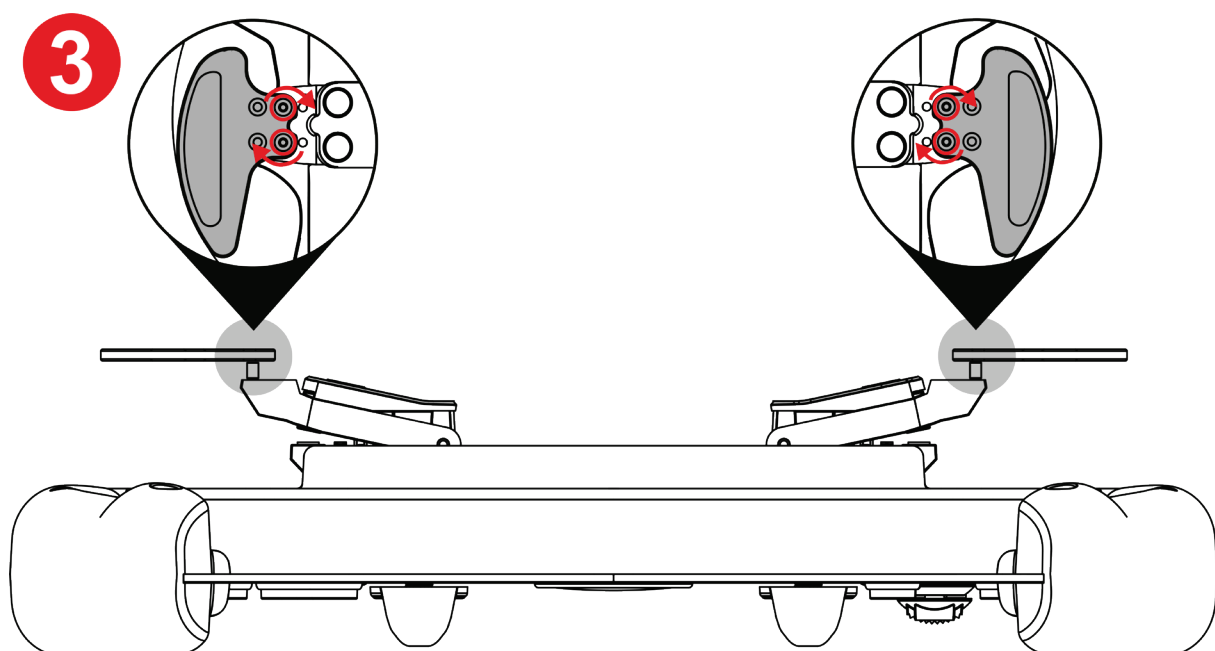

3 Aprieta los cuatro tornillos de las levas de cambio con la llave Torx suministrada.



Cómo ajustar el alcance de las levas de cambio

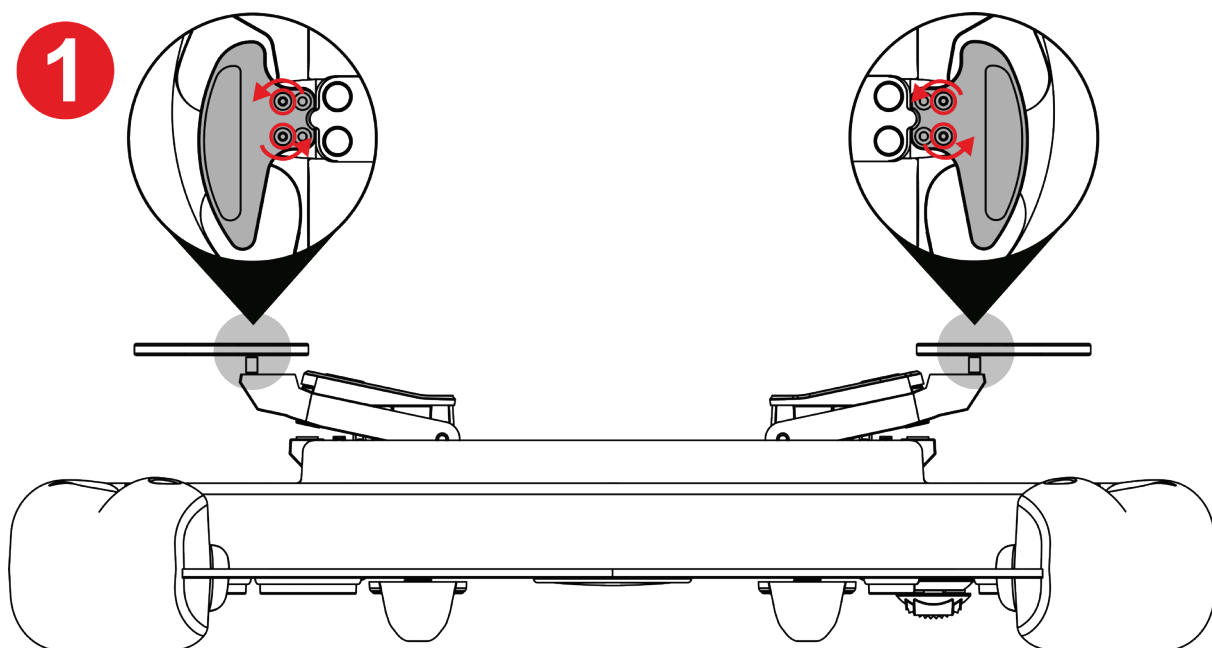

1 Afloja los cuatro tornillos de las levas de cambio con la llave Torx suministrada.

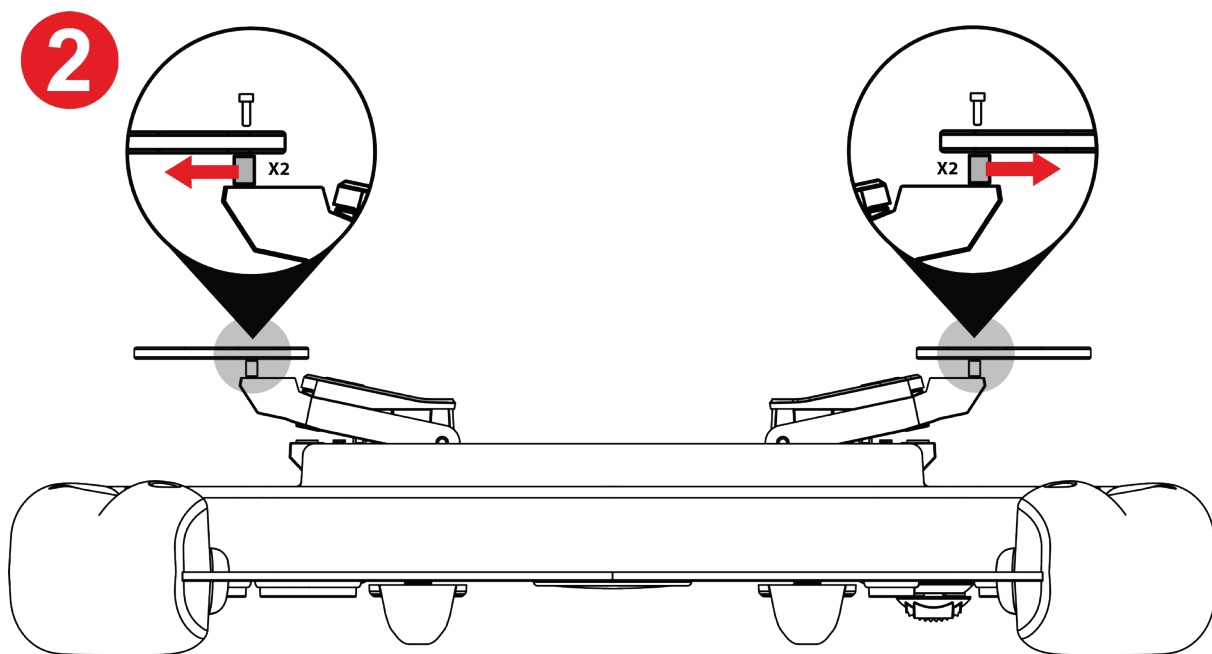

2 Retira los espaciadores.

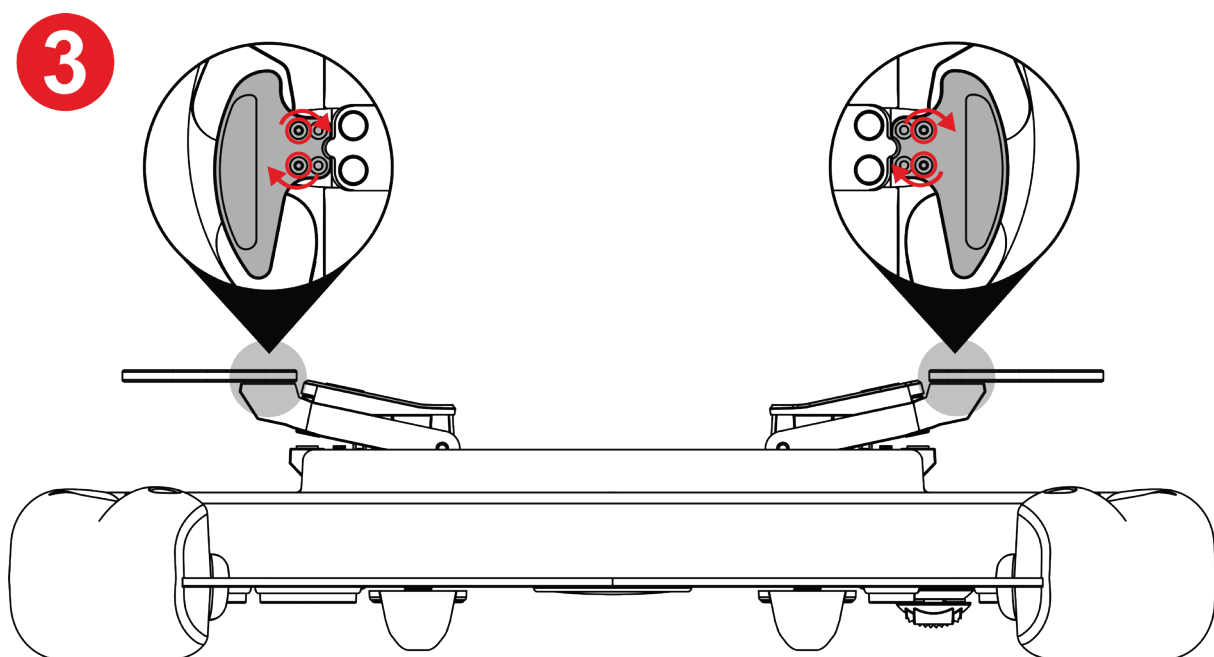

3 Aprieta los cuatro tornillos de las levas de cambio con la llave Torx suministrada.



Cómo ajustar la sensibilidad magnética y el nivel sonoro de las levas de cambio

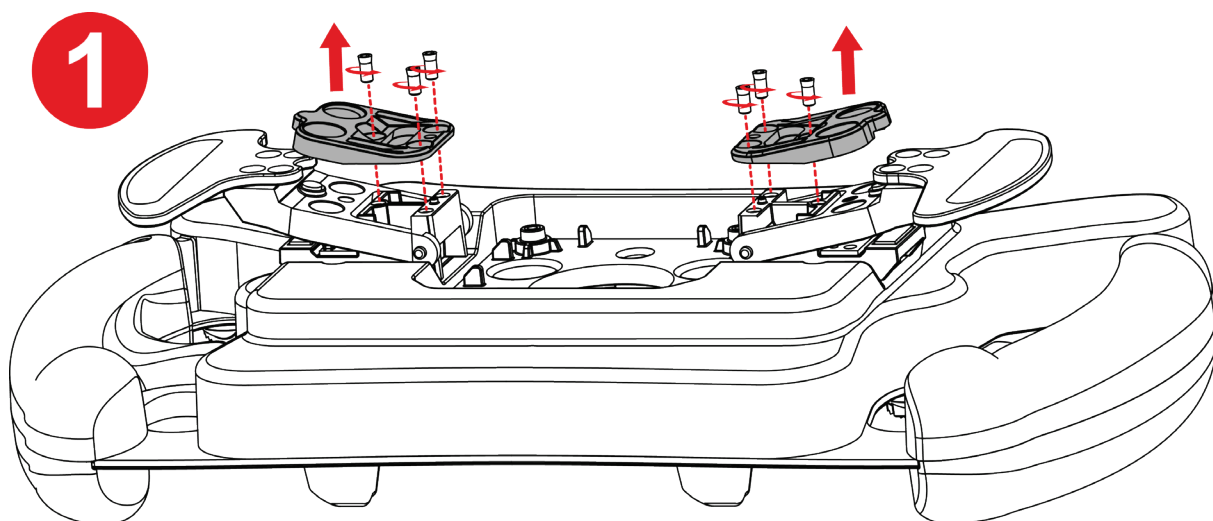

1 Retira los topes magnéticos aflojando los seis tornillos de tope con la llave Torx suministrada.

2

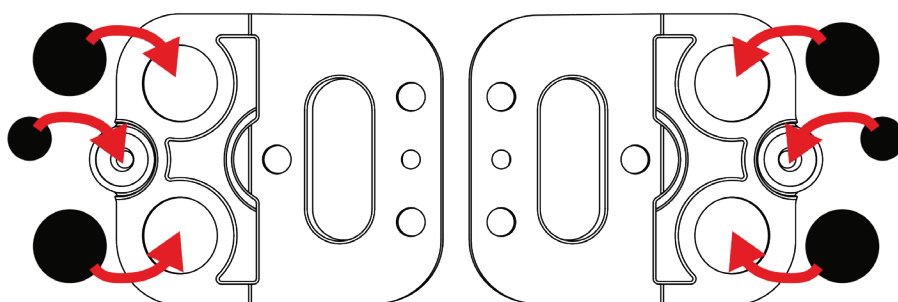
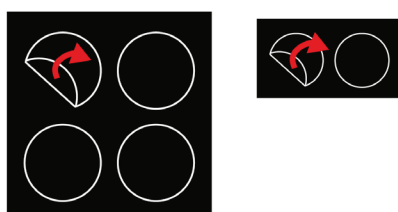

2 Quita el protector a las almohadillas suministradas y fíjalas en los lugares apropiados debajo de los topes magnéticos.



Consulta la **tabla de sensibilidad magnética y atenuación del sonido de las levas de cambio** para conocer las posibles configuraciones y sus efectos.



3

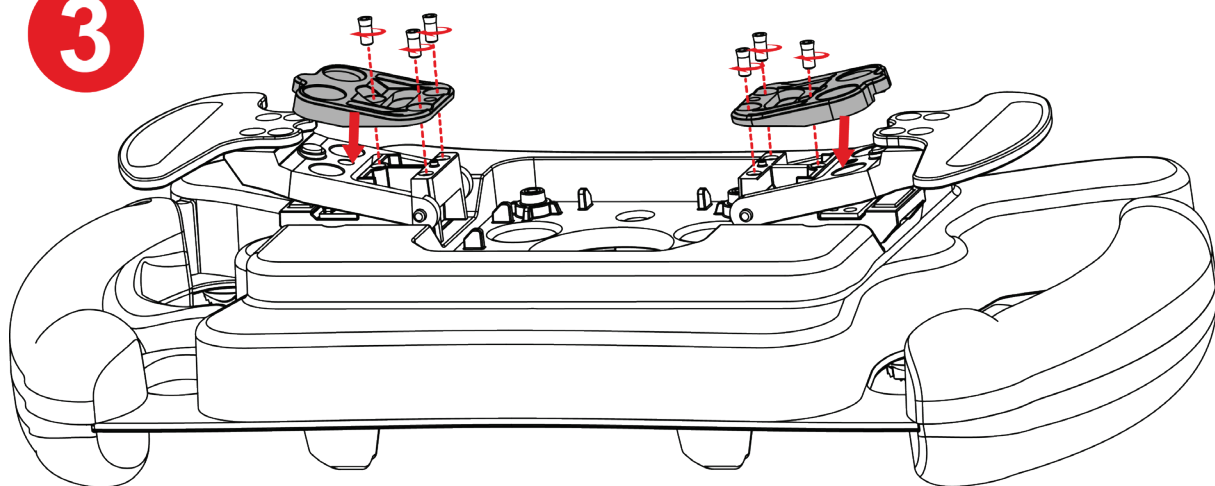

3 Vuelve a instalar los topes magnéticos y aprieta los seis tornillos de tope con la llave Torx suministrada.

Tabla de sensibilidad magnética y atenuación del sonido de las levas de cambio

	 (por defecto)		
Sensibilidad magnética			
Sonido			



8. Preguntas frecuentes y soporte técnico

¿Tienes preguntas sobre el Ferrari 488 GT3 Wheel Add-On o estás experimentando problemas técnicos? Si es así, visita el sitio web de soporte técnico de Thrustmaster: <https://support.thrustmaster.com/product/ferrarif488gt3addon>.

En esta página también puedes actualizar el firmware del volante.



THRUSTMASTER®

FERRARI 488 GT3 WHEEL ADD-ON

PC (Windows 10/11)

PS4™ / PS5™

Xbox Series / Xbox One

Manual do Utilizador



Leia atentamente as instruções fornecidas neste manual **antes** de instalar o produto, **antes** de qualquer utilização do produto e **antes** de realizar qualquer manutenção. Siga as instruções de segurança. O incumprimento destas instruções pode resultar em acidentes e/ou danos. Guarde este manual para poder consultar as instruções no futuro.

ÍNDICE

1.	CONTEÚDO DA EMBALAGEM.....	5
2.	CARACTERÍSTICAS	6
3.	INFORMAÇÕES RELATIVAS À UTILIZAÇÃO DO VOLANTE.....	8
4.	INSTALAÇÃO DO SUPORTE DE DESENGATE RÁPIDO.....	13
	<i>Instalação do suporte de desengate rápido para base de engate.....</i>	<i>14</i>
	<i>Instalação do suporte de desengate rápido para base de rosca.....</i>	<i>17</i>
5.	MAPEAMENTO.....	21
	<i>Mapeamento para o PC.....</i>	<i>21</i>
	<i>Mapeamento para a PS4™/PS5™</i>	<i>22</i>
	<i>Mapeamento para a Xbox Series/Xbox One</i>	<i>23</i>
6.	FUNCIONAMENTO DAS LUZES LED.....	24
	<i>Como entrar/sair do menu LED</i>	<i>25</i>

Como ajustar a intensidade das luzes

LED27

Como alterar o modo das luzes LED: GT3

ou Formula28

7. PERSONALIZAÇÃO DAS PATILHAS DE

VELOCIDADES29

Como ajustar o espaçamento das patilhas

de velocidades.....31

Como ajustar o alcance das patilhas de

velocidades33

Como ajustar a sensibilidade magnética e

o nível sonoro das patilhas de

velocidades35

8. PERGUNTAS FREQUENTES E SUPORTE

TÉCNICO37



FERRARI 488 GT3 WHEEL ADD-ON

Faça parte da lenda das corridas de GT com o Ferrari 488 GT3 Wheel Add-On, um volante concebido para alto desempenho e compatível com todas as bases de volantes Thrustmaster.

Este manual irá ajudá-lo(a) a instalar e utilizar o seu Ferrari 488 GT3 Wheel Add-On nas melhores condições. Antes de começar a competir, leia atentamente as instruções e os avisos: eles irão ajudá-lo(a) a desfrutar ao máximo do seu produto.



1. Conteúdo da embalagem

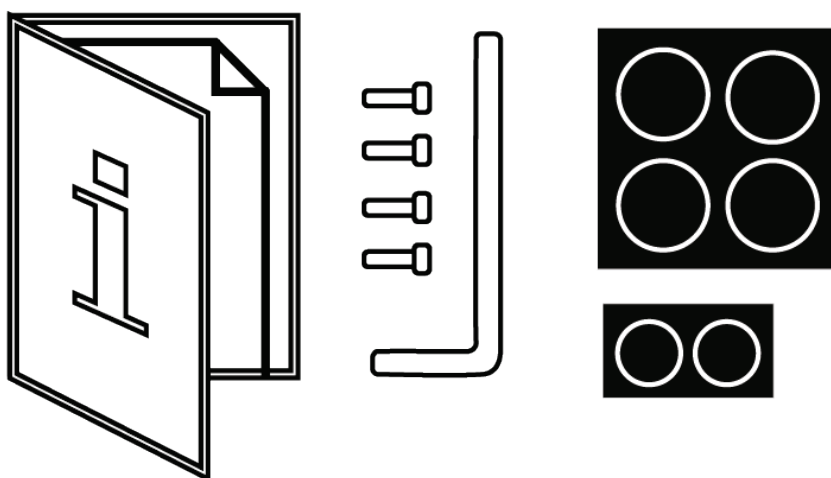
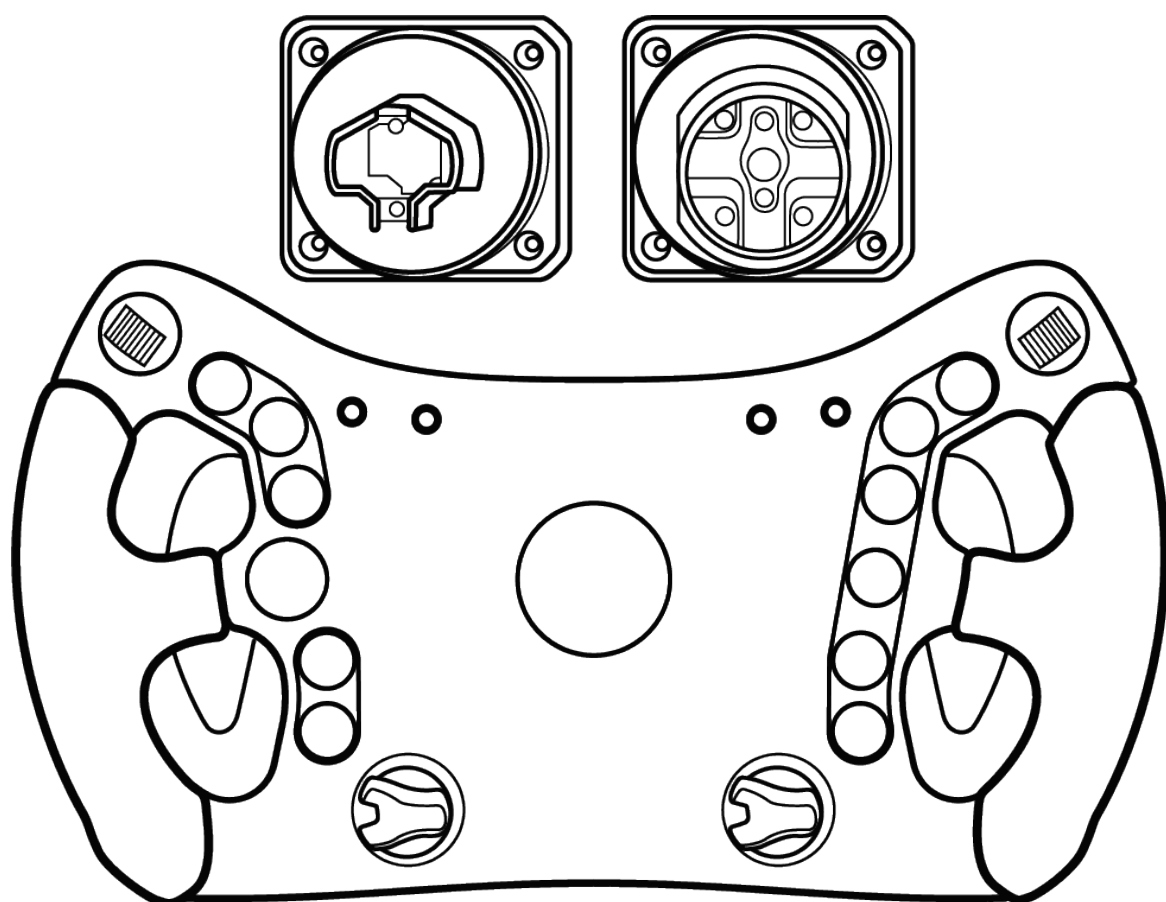



2. Características

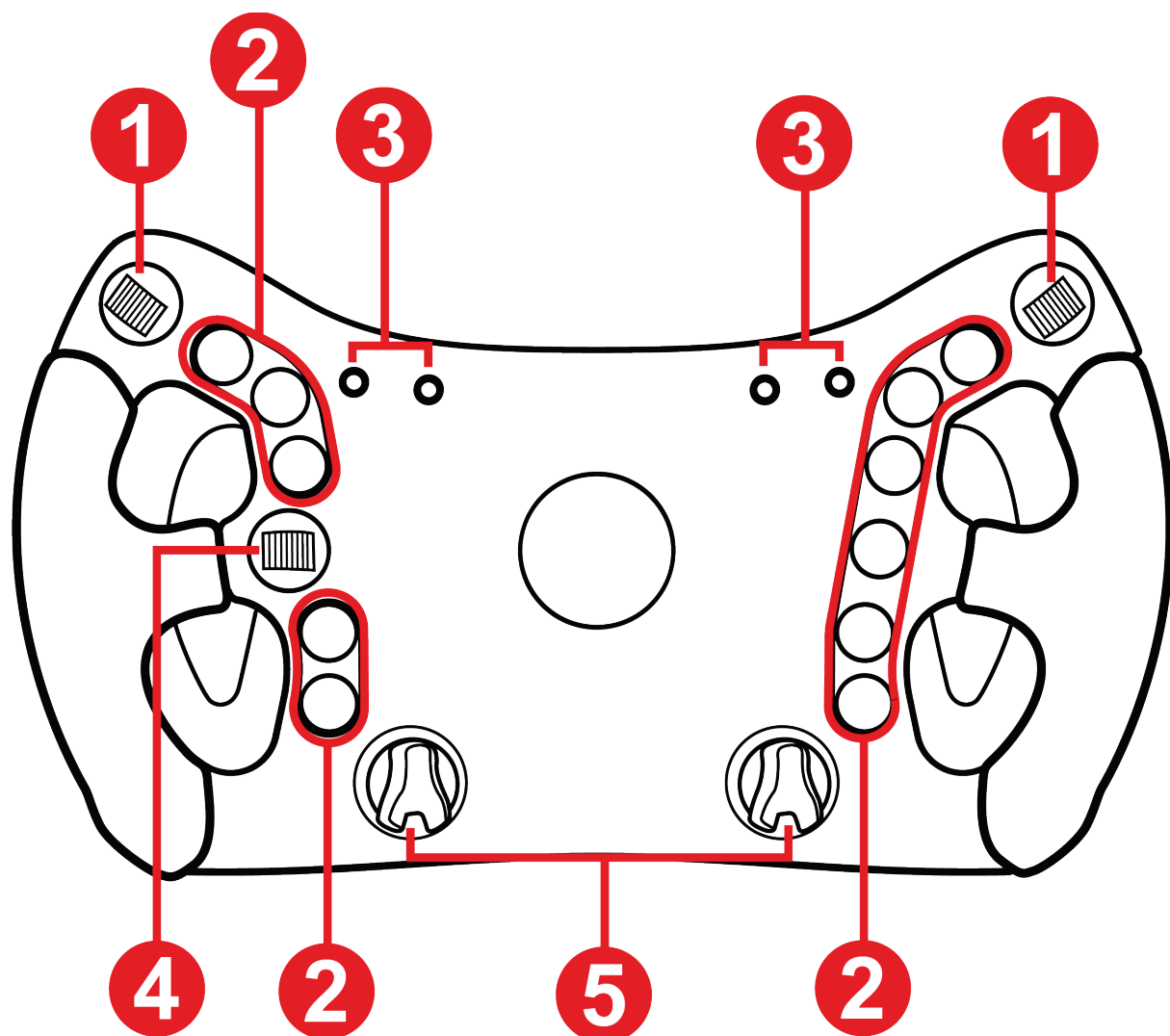

- ❶ Codificadores controlados com o polegar
- ❷ 11 botões de ações
- ❸ Luzes LED das RPM e dados da corrida (bandeiras, idas às boxes)
- ❹ D-pad
- ❺ Codificadores giratórios

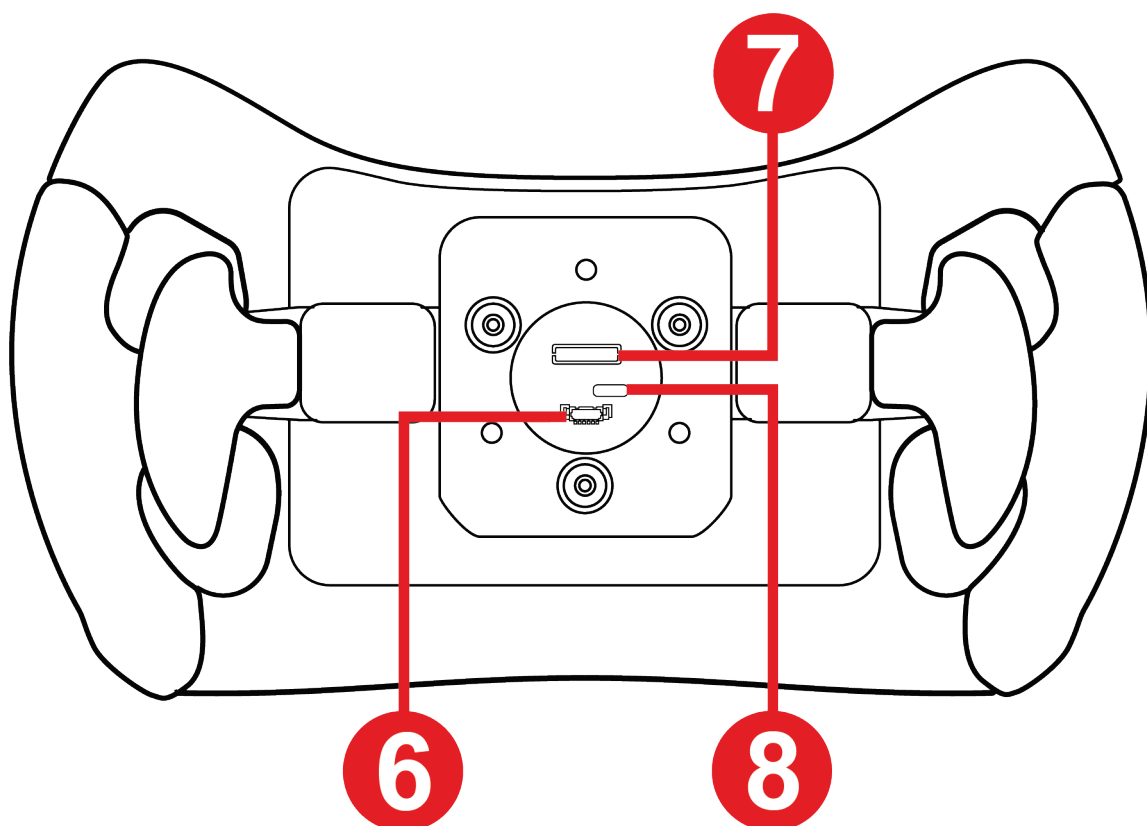

⑥ Porta de ligação para suporte de desengate rápido para base de rosca

⑦ Porta de ligação para suporte de desengate rápido para base de engate

⑧ Porta USB-C (se for necessário atualizar o firmware – cabo não incluído)

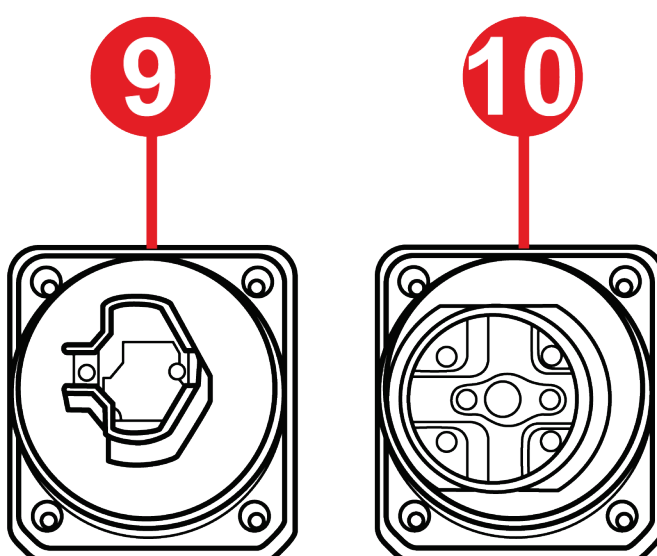

⑨ Suporte de desengate rápido para base de engate

⑩ Suporte de desengate rápido para base de rosca



3. Informações relativas à utilização do volante



Documentação

Antes de utilizar este produto, leia atentamente esta documentação e conserve-a para consulta futura.



Choque elétrico

- Conserve o produto num local seco e não o exponha ao pó nem à luz solar.
- Não torça nem puxe os conectores e cabos.
- Siga as instruções de ligação.
- Não derrame líquidos sobre o produto nem sobre os respetivos conectores.
- Não provoque um curto-circuito do produto.
- Nunca desmonte o produto (exceto nos casos de personalização especificados neste manual), não o atire para o fogo e não o exponha a altas temperaturas.
- Não abra o dispositivo: não contém peças reparáveis pelo utilizador. Quaisquer reparações devem realizadas pelo fabricante, por uma agência especificada ou por um técnico qualificado.



Proteção da área de jogo

- Não coloque na área de jogo qualquer objeto que possa perturbar a prática por parte do utilizador, ou que possa provocar um movimento ou uma interrupção inadequados por outra pessoa (por exemplo, chávena de café, telefone, chaves).
- Não cubra os cabos de alimentação com uma alcatifa, tapete, cobertor, cobertura ou qualquer outro item e não coloque quaisquer cabos onde as pessoas irão andar.



Lesões causadas pelos efeitos Force Feedback e movimentos repetidos

A utilização de um volante de efeitos Force Feedback pode causar dores nos músculos ou nas articulações.

Para evitar quaisquer problemas:

- Faça um aquecimento prévio e evite longos períodos de prática.
- Faça uma pausa de 10 a 15 minutos após cada hora de prática.
- Se sentir fadiga ou dores nas mãos, pulsos, braços, pés ou pernas, prima o botão para desligar os efeitos Force Feedback, desligue a base e descanse durante algumas horas antes de voltar a praticar.
- Se os sintomas ou as dores acima indicados persistirem quando voltar a praticar, pare de praticar e consulte o seu médico.
- Não defina os efeitos Force Feedback para um nível demasiado alto relativamente à sua experiência e ao seu estado físico.
- Mantenha o dispositivo fora do alcance de pessoas com menos de 16 anos de idade.
- Certifique-se de que a base e o volante estão fixados devidamente, de acordo com as instruções do manual.



Risco de rotações imprevistas, potentes e rápidas: nunca coloque uma mão ou um braço através das aberturas no aro do volante ou na trajetória de rotação do volante.

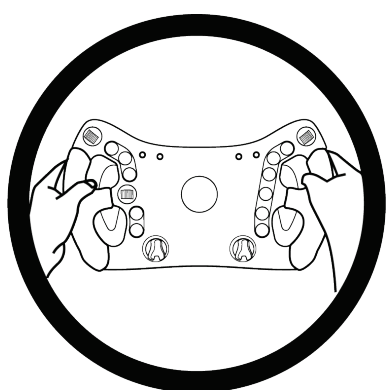

Ao utilizar o produto, coloque sempre ambas as mãos posicionadas corretamente no volante sem nunca largá-lo completamente.



Produto para ser manuseado unicamente por pessoas com **16 anos de idade ou mais velhas.**



4. Instalação do suporte de desengate rápido

O **Ferrari 488 GT3 Wheel Add-On** inclui dois suportes de desengate rápido, correspondendo aos formatos das bases Thrustmaster.

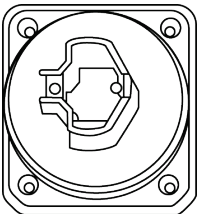
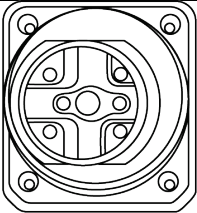
Sistema	Compatibilidade
 <p>Suporte de desengate rápido para base de engate</p>	T818, T818 Ferrari SF1000 Simulator e bases Thrustmaster futuras.
 <p>Suporte de desengate rápido para base de rosca</p>	T-GT / T-GT II Servo Base, T300 RS Servo Base, TS PC Racer, TS-XW, TX Racing Wheel Servo Base, TS-XW Servo Base.



Antes de cada utilização, verifique se o **Ferrari 488 GT3 Wheel Add-On** continua fixado firmemente ao suporte, de acordo com as instruções do manual relativas à base.



Instalação do suporte de desengate rápido para base de engate rápido

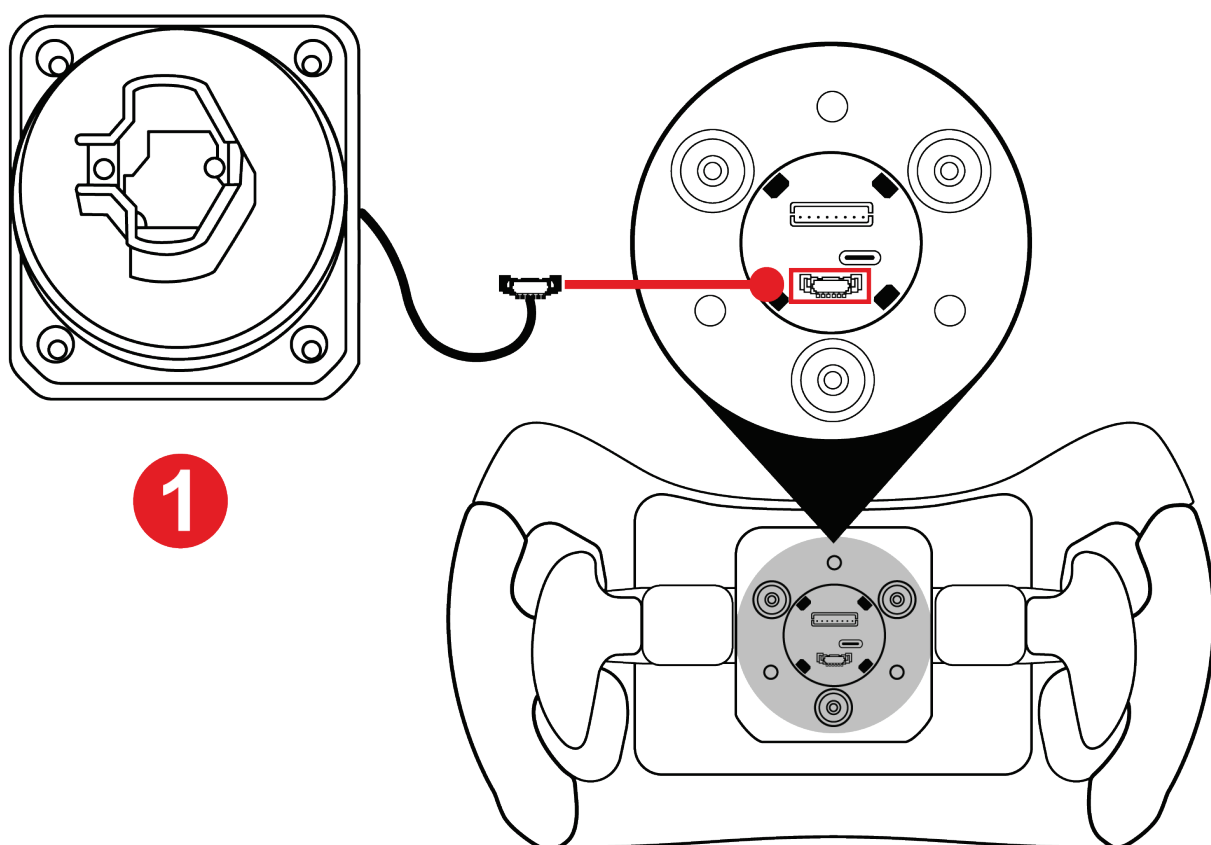

1 Ligue o conector do suporte de desengate rápido à porta correspondente na parte posterior do volante.



Para evitar entalar o cabo, recolha-o para dentro do respetivo compartimento antes de fixar o suporte.

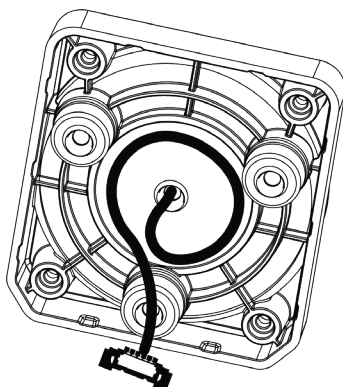

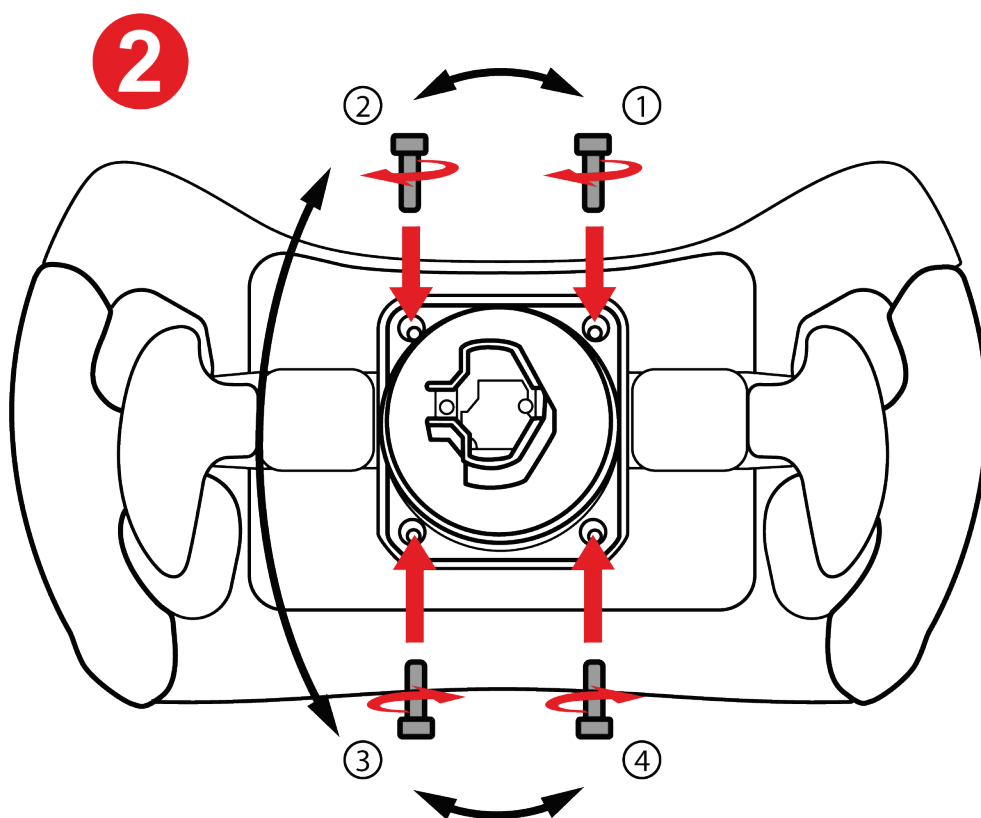

2 Insira o suporte de desengate rápido e aperte-o utilizando a chave Torx fornecida.



Ao montar o suporte, não aperte demasiado os parafusos.

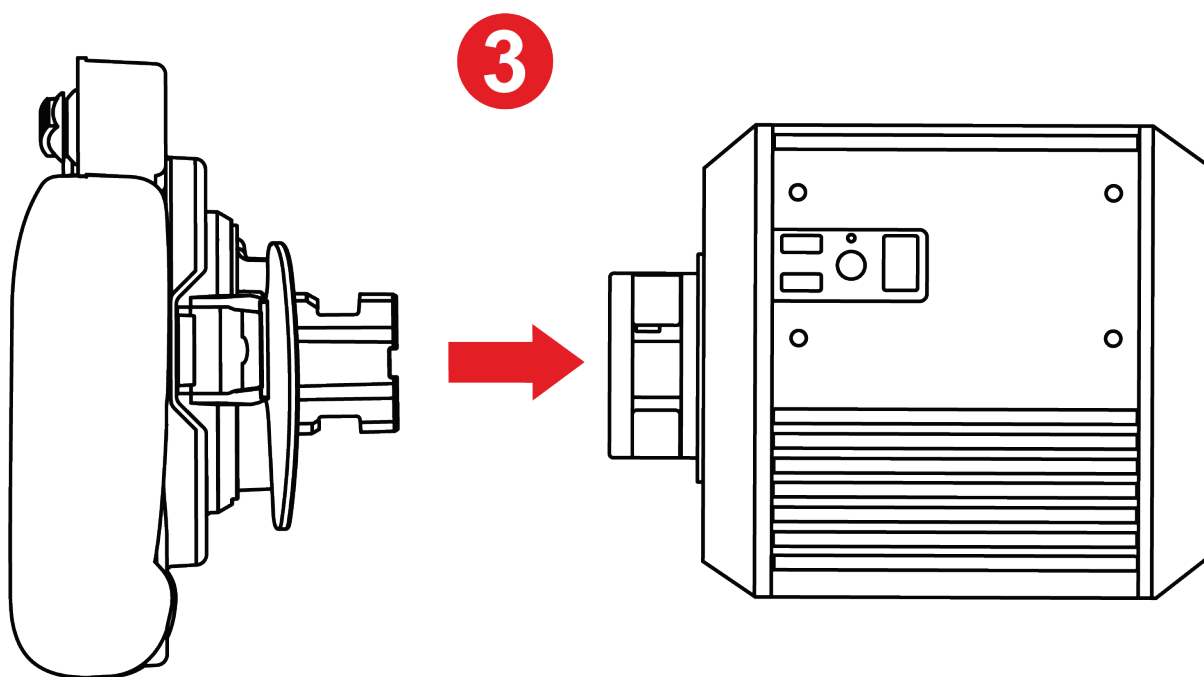

3 Monte o volante na base.



Siga o procedimento de instalação especificado no manual do utilizador da base.



Instalação do suporte de desengate rápido para base de rosca

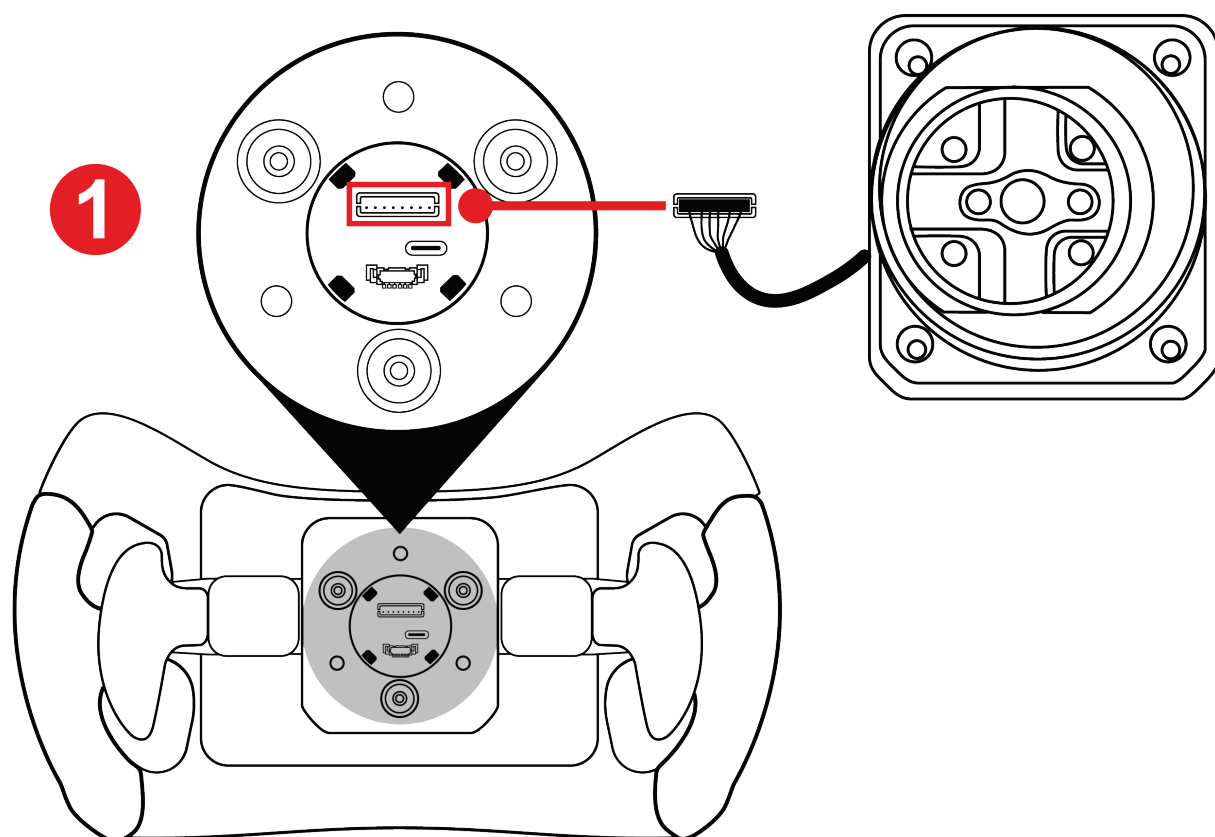

1 Ligue o conector do suporte de desengate rápido à porta correspondente na parte posterior do volante.



Para evitar entalar o cabo, recolha-o para dentro do respetivo compartimento antes de fixar o suporte.

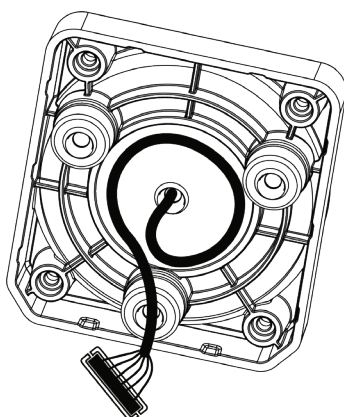

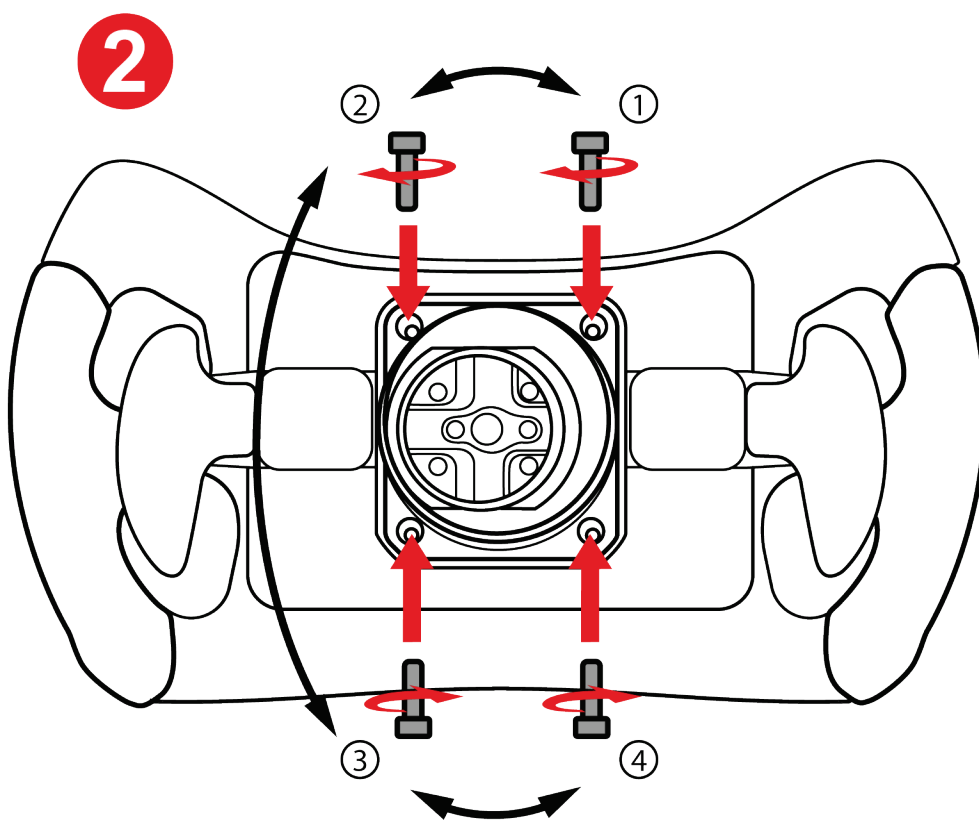

2 Insira o suporte de desengate rápido e aperte-o utilizando a chave Torx fornecida.



Ao montar o suporte, não aperte demasiado os parafusos.

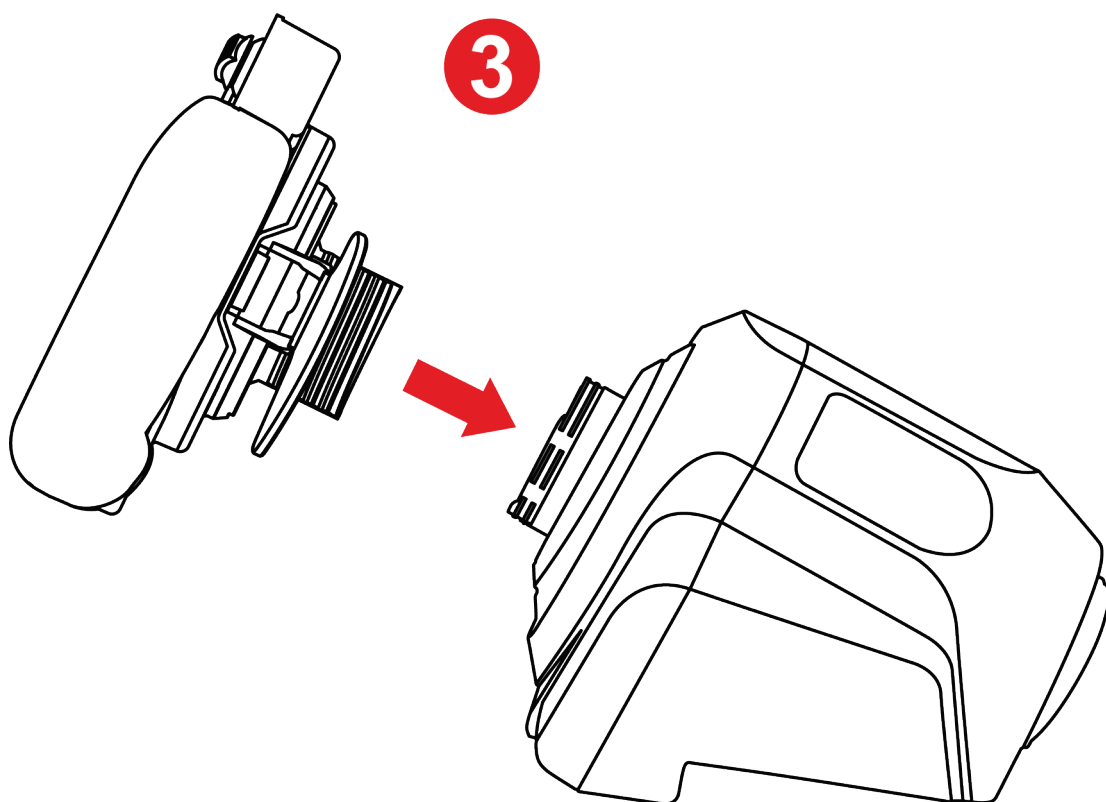

3 Monte o volante na base.



Siga o procedimento de instalação especificado no manual do utilizador da base.



Nunca ligue o Quick Release Adapter (fornecido com a base T818 e vendido à parte) ao suporte de desengate rápido caso pretenda utilizá-lo numa base T818.

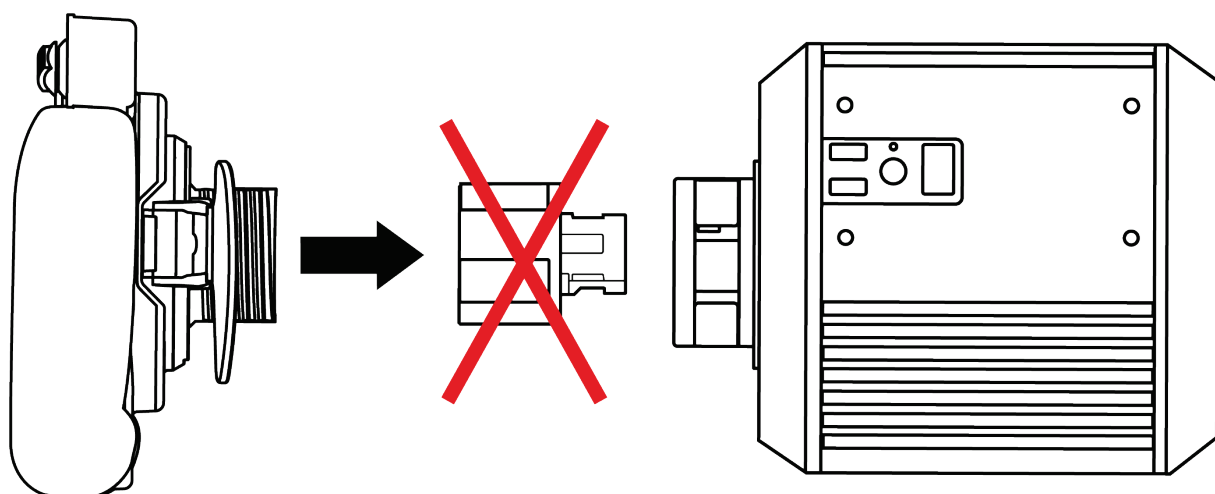
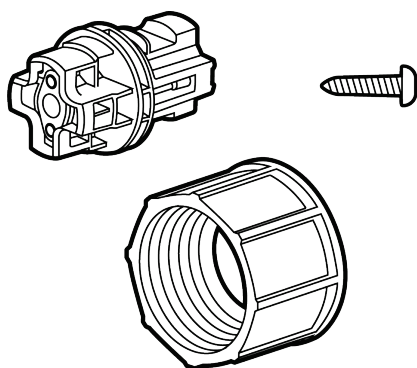

Para a utilização numa base T818 ou numa base equipada com um conector para base de engate, utilize apenas o **suporte de desengate rápido para base de engate** fornecido com o **Ferrari 488 GT3 Wheel Add-On**.



5. Mapeamento

Mapeamento para o PC

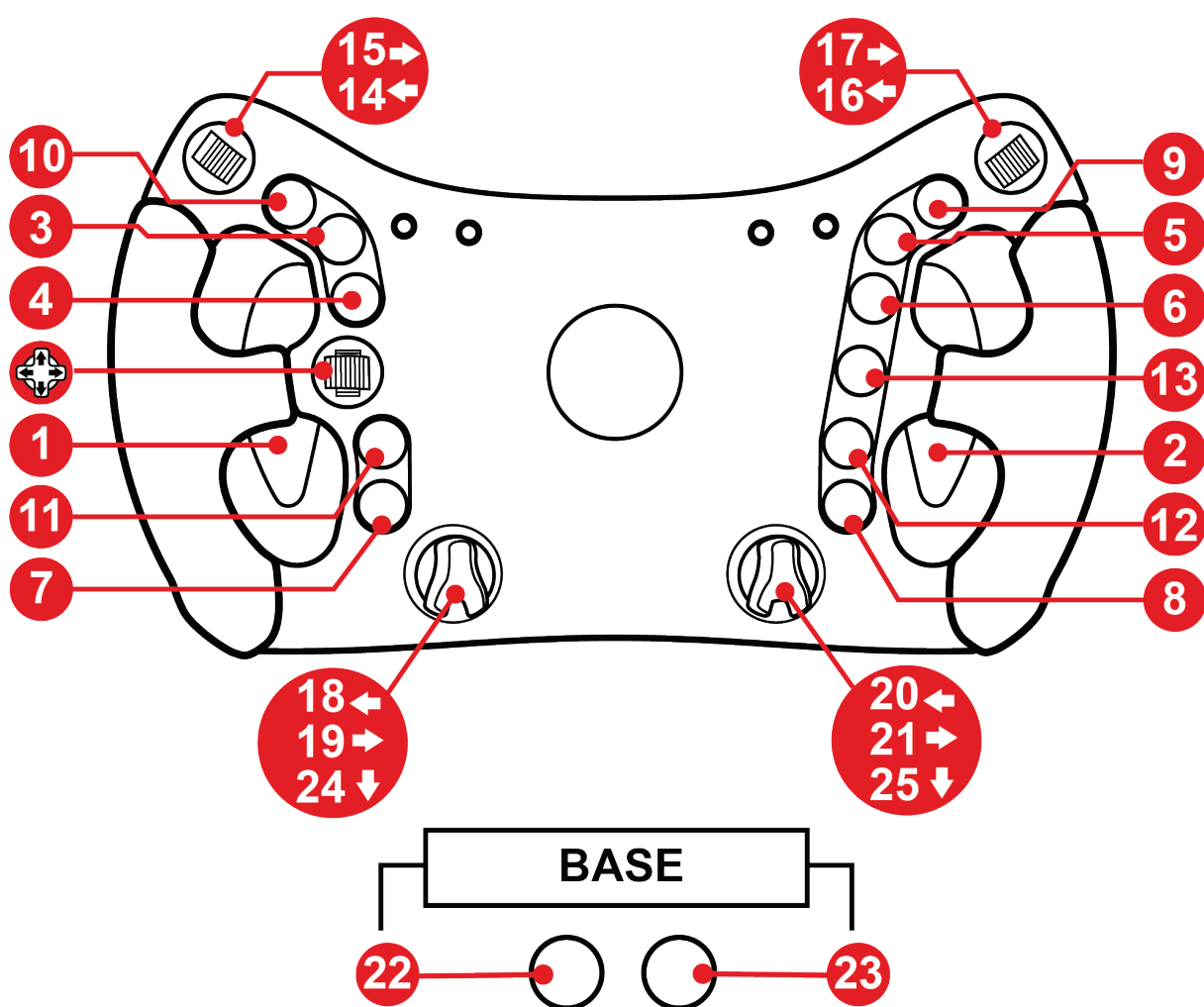



Mapeamento para a PS4™/PS5™

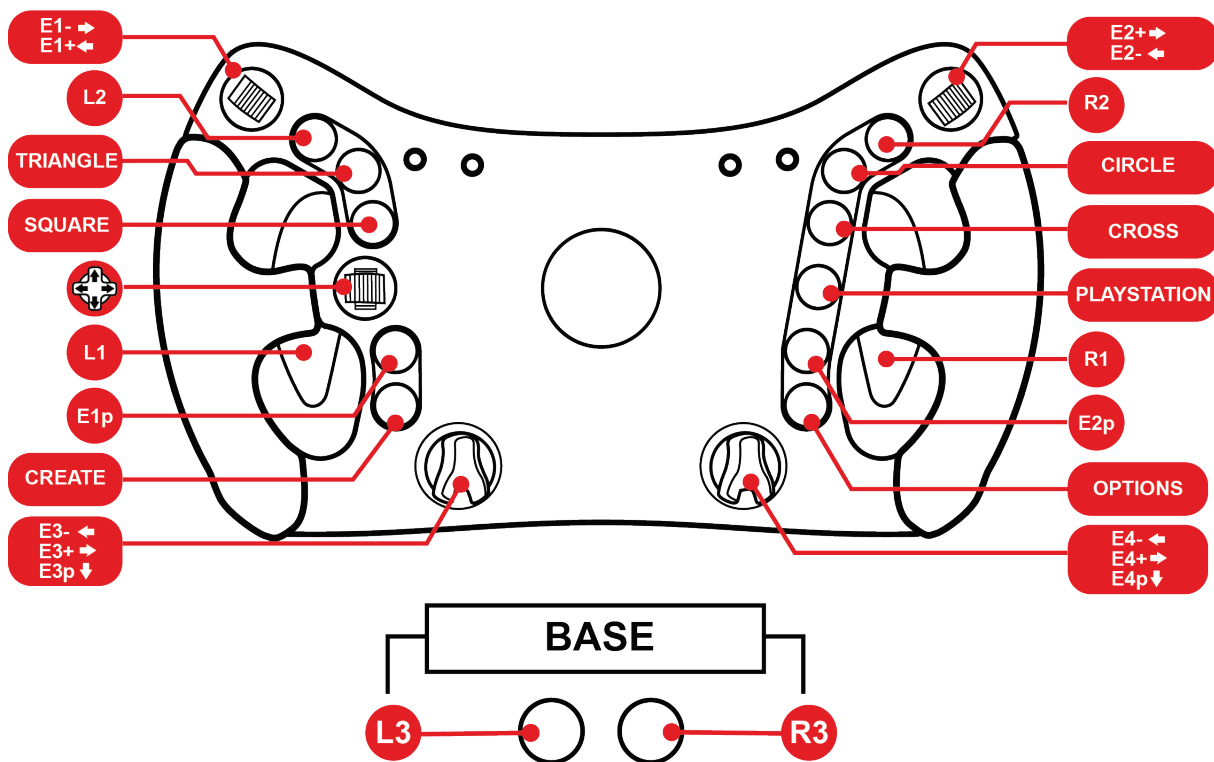



Mapeamento para a Xbox Series/Xbox One

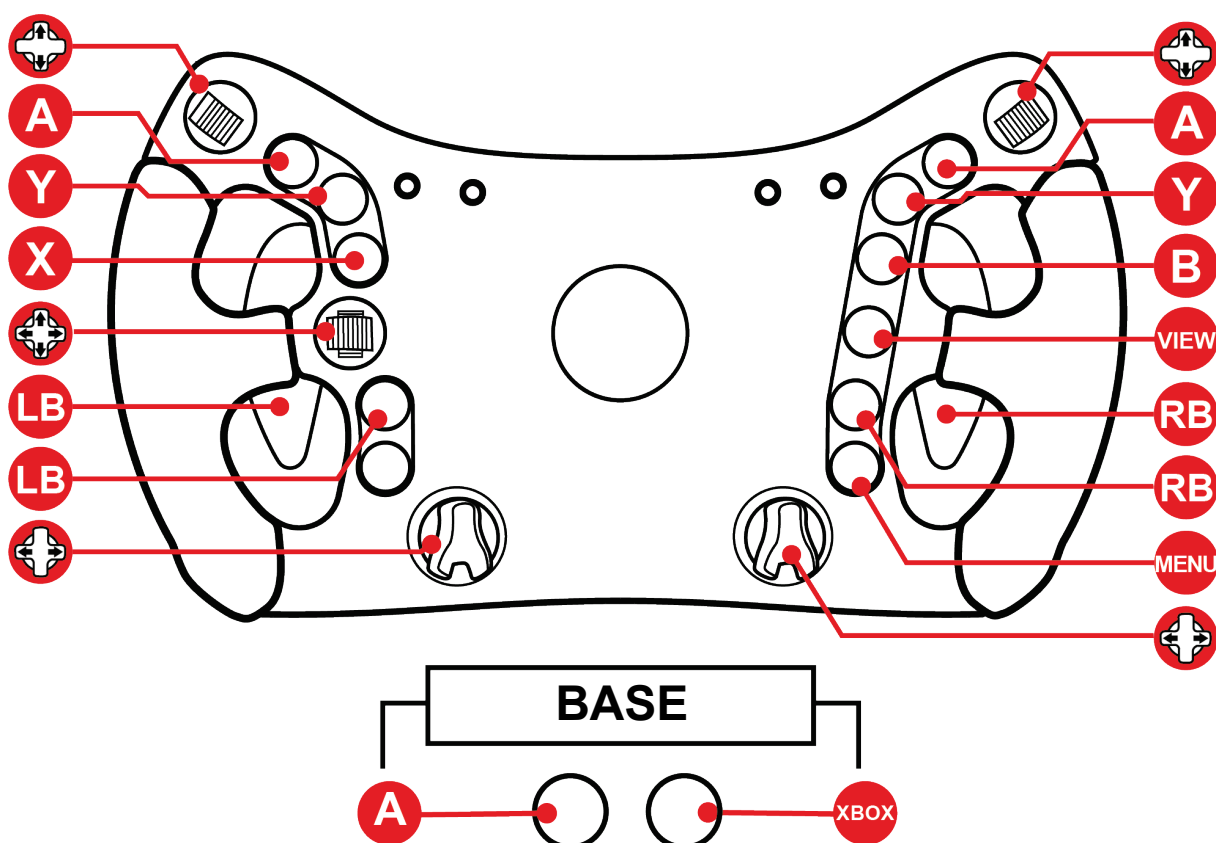

Na Xbox Series e Xbox One:

- As luzes LED no Ferrari 488 GT3 Wheel Add-On não são funcionais devido às restrições do protocolo da consola.
- Algumas funções (codificadores, número de botões) são limitadas pelo protocolo da consola.



6. Funcionamento das luzes LED

O **Ferrari 488 GT3 Wheel Add-On** apresenta dados da corrida através das luzes LED: bandeiras, idas às boxes e RPM.

Os dados apresentados podem ser personalizados (intensidade e cor das luzes LED das RPM), consoante o modo (GT3 ou Formula).

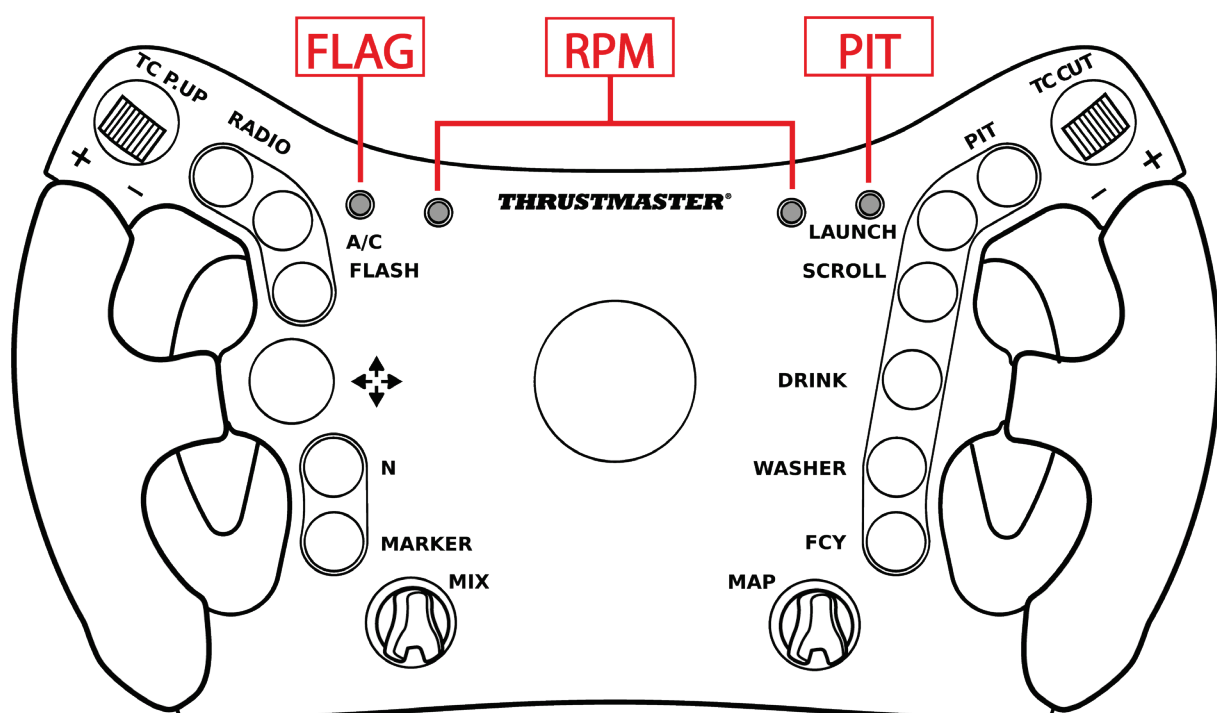

As luzes LED são funcionais no PC e PS4™/PS5™. Na Xbox Series e Xbox One, as luzes LED não são funcionais devido às restrições do protocolo da consola.



Como entrar/sair do menu LED

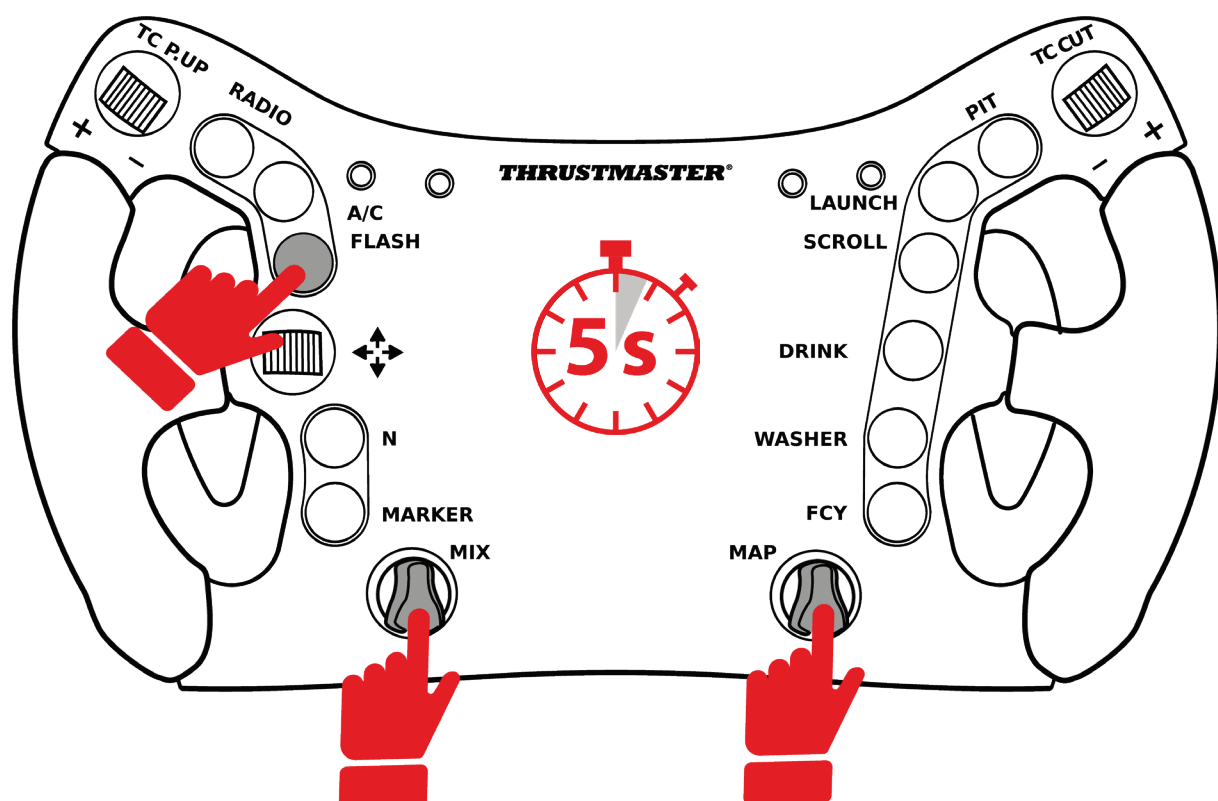

- Para entrar no menu LED, prima simultaneamente o botão **FLASH** e ambos os **codificadores giratórios** durante **5 segundos** e em seguida solte-os.
- Para sair do menu LED, prima simultaneamente o botão **FLASH** e ambos os **codificadores giratórios** e em seguida solte-os.

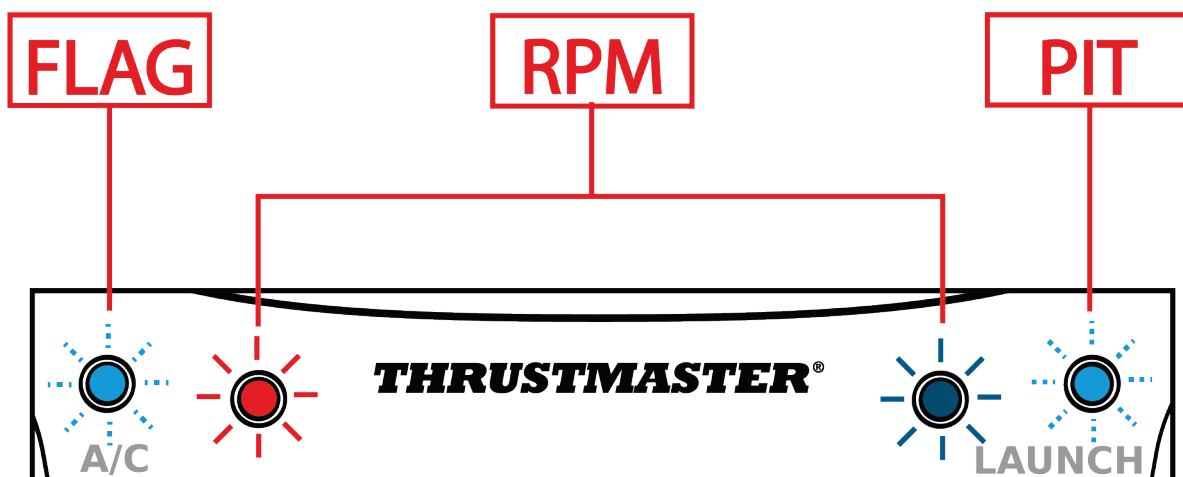

Entrar no menu LED: as luzes LED de FLAG e PIT e uma das luzes LED das RPM (vermelha à esquerda ou azul à direita) acendem-se.



Sair do menu LED: as quatro luzes LED apagam-se.



Como ajustar a intensidade das luzes LED

- Entre no menu LED premindo simultaneamente o botão **FLASH** e ambos os **codificadores giratórios** durante 5 segundos e em seguida solte-os.
- Rode o **codificador esquerdo (MIX)** para a esquerda para diminuir a intensidade, ou para a direita para aumentar a intensidade.



- Saia do menu LED premindo simultaneamente o botão **FLASH** e ambos os **codificadores giratórios** e em seguida solte-os.



Como alterar o modo das luzes LED: GT3 ou Formula

- Entre no menu LED premindo simultaneamente o botão **FLASH** e ambos os **codificadores giratórios** durante **5 segundos** e em seguida solte-os.
- Rode o **codificador direito (MAP)** para a esquerda para selecionar o modo GT3 (luz LED vermelha), ou para a direita para selecionar o modo Formula (luz LED azul).



Modo GT3 (modo predefinido)



Modo FORMULA

- Saia do menu LED premindo simultaneamente o botão **FLASH** e ambos os **codificadores giratórios** e em seguida solte-os.



7. Personalização das patilhas de velocidades

As patilhas de velocidades do **Ferrari 488 GT3 Wheel Add-On** são ajustáveis em termos de **espaçamento** e **alcance**.

O **espaçamento** consiste em ajustar a patilha de velocidades em largura, o que altera a distância entre o punho e a patilha de velocidades.

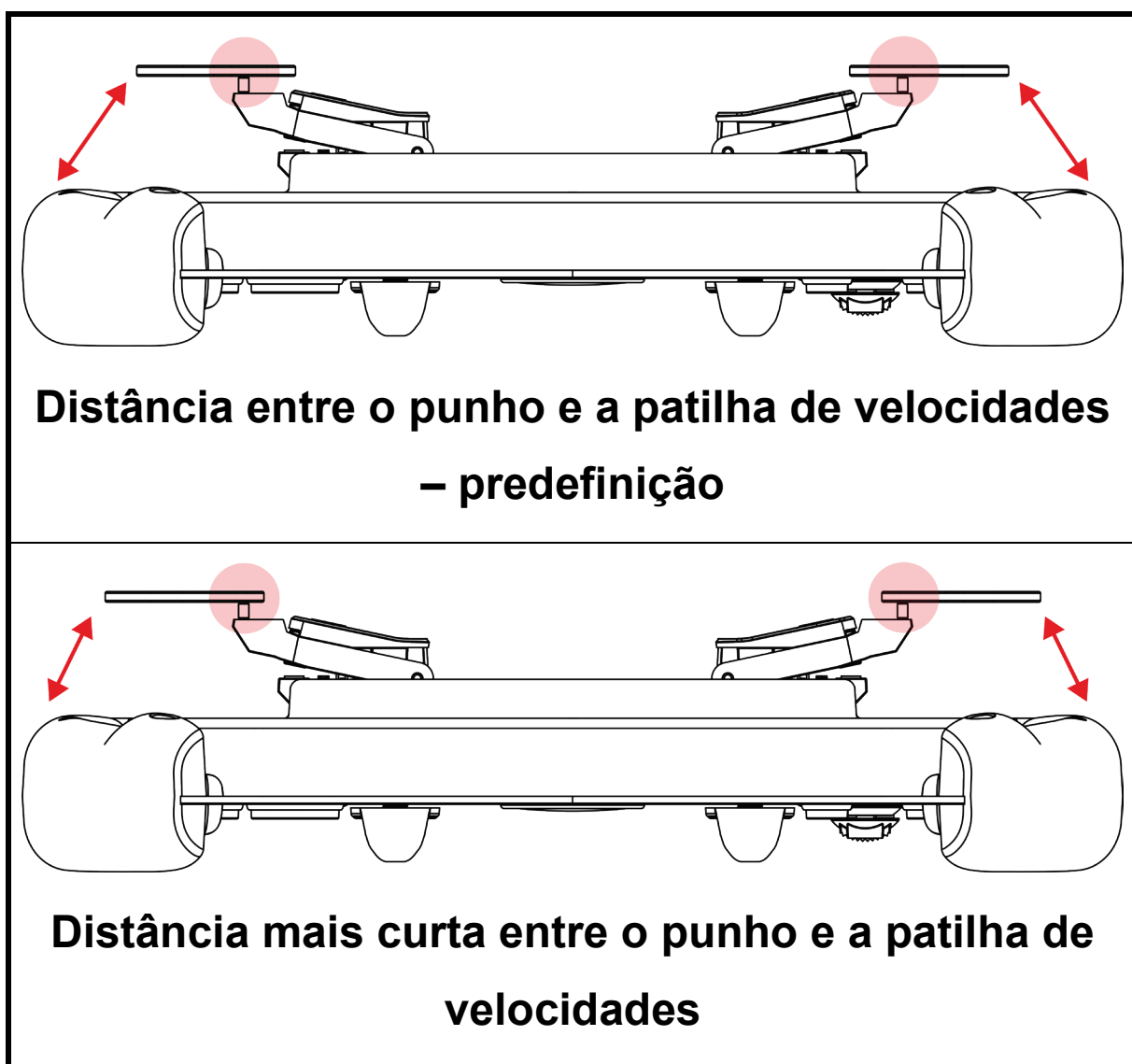



O ajuste do **alcance** utilizando os espaçadores altera a distância de ativação da patilha de velocidades.

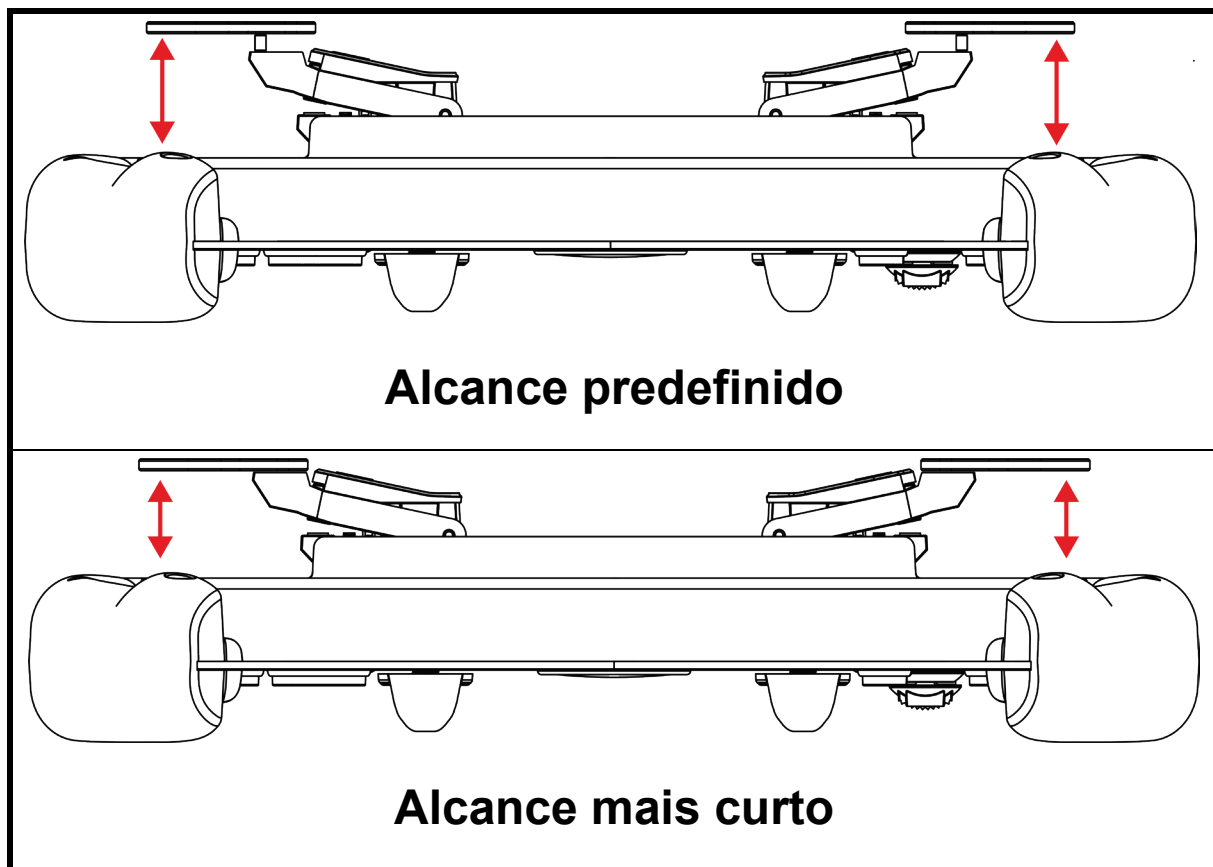

É igualmente possível ajustar a **sensibilidade magnética** e o **nível sonoro** produzido pelas patilhas de velocidades utilizando o conjunto de almofadas de amortecimento fornecido.

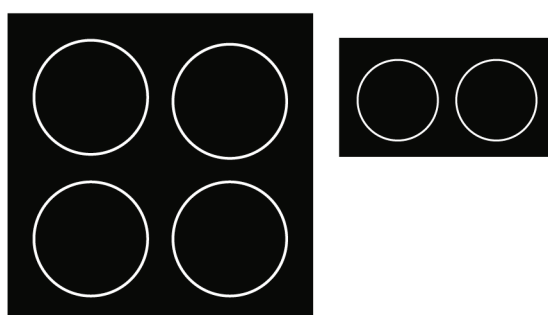



Como ajustar o espaçamento das patilhas de velocidades

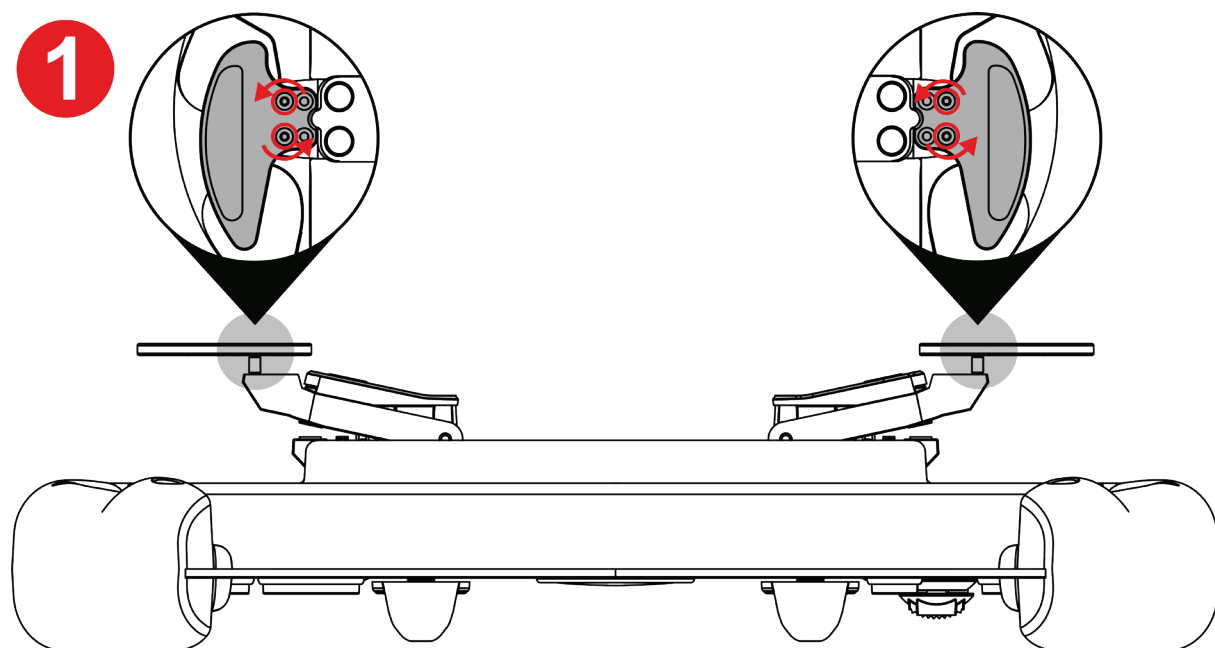

1 Desaperte os quatro parafusos das patilhas de velocidades utilizando a chave Torx fornecida.

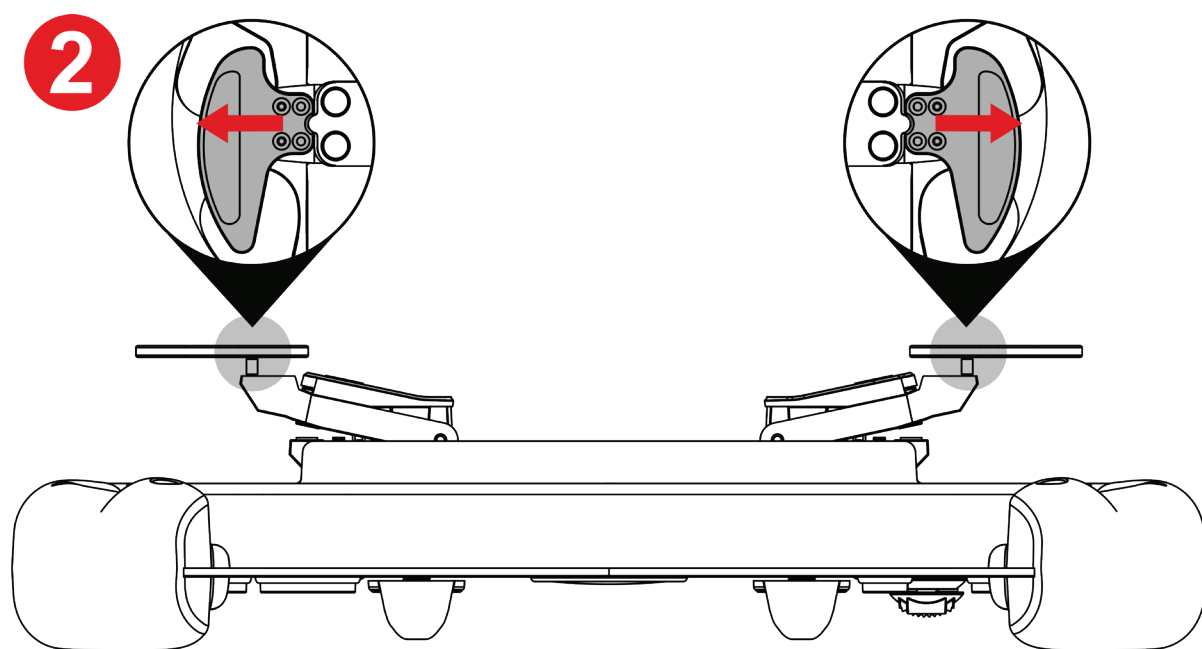

2 Mova as patilhas de velocidades para fora de modo a coincidirem com os orifícios.

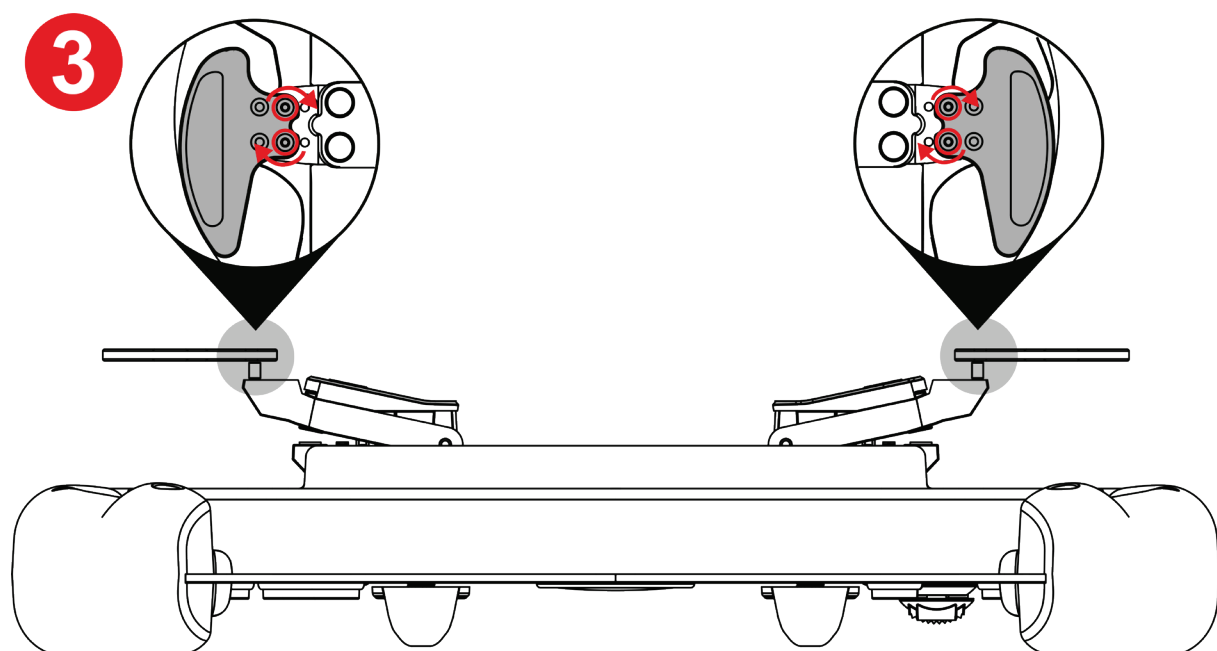

3 Aperte os quatro parafusos das patilhas de velocidades utilizando a chave Torx fornecida.



Como ajustar o alcance das patilhas de velocidades

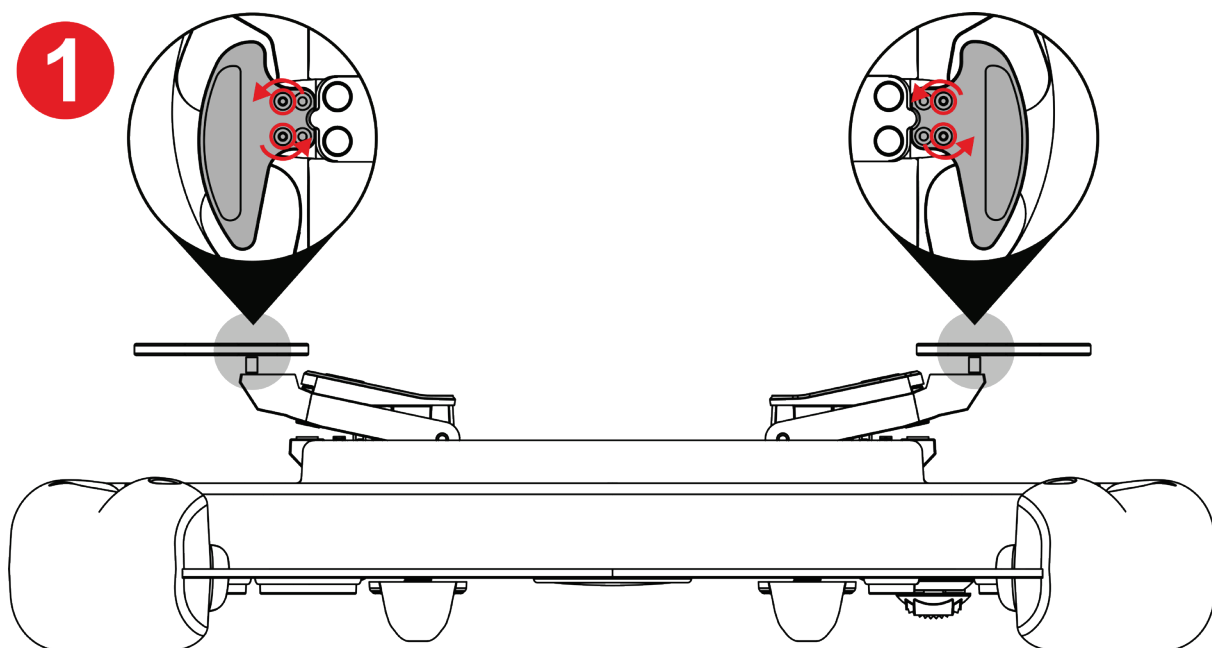

1 Desaperte os quatro parafusos das patilhas de velocidades utilizando a chave Torx fornecida.

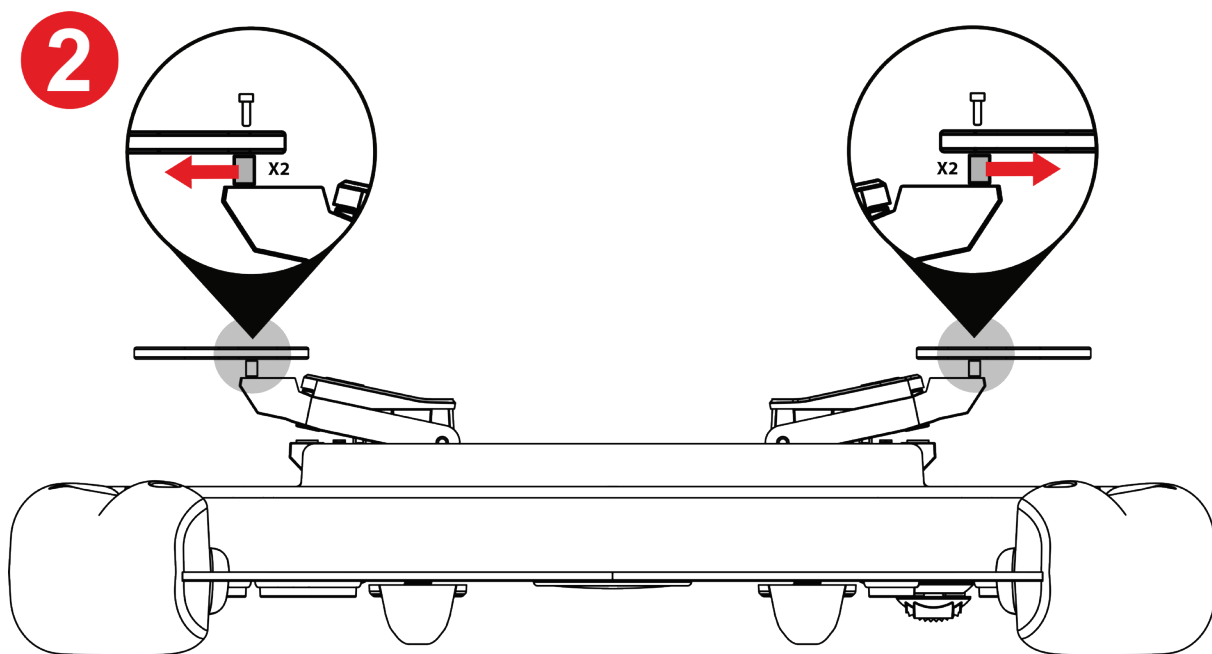

2 Remova os espaçadores.

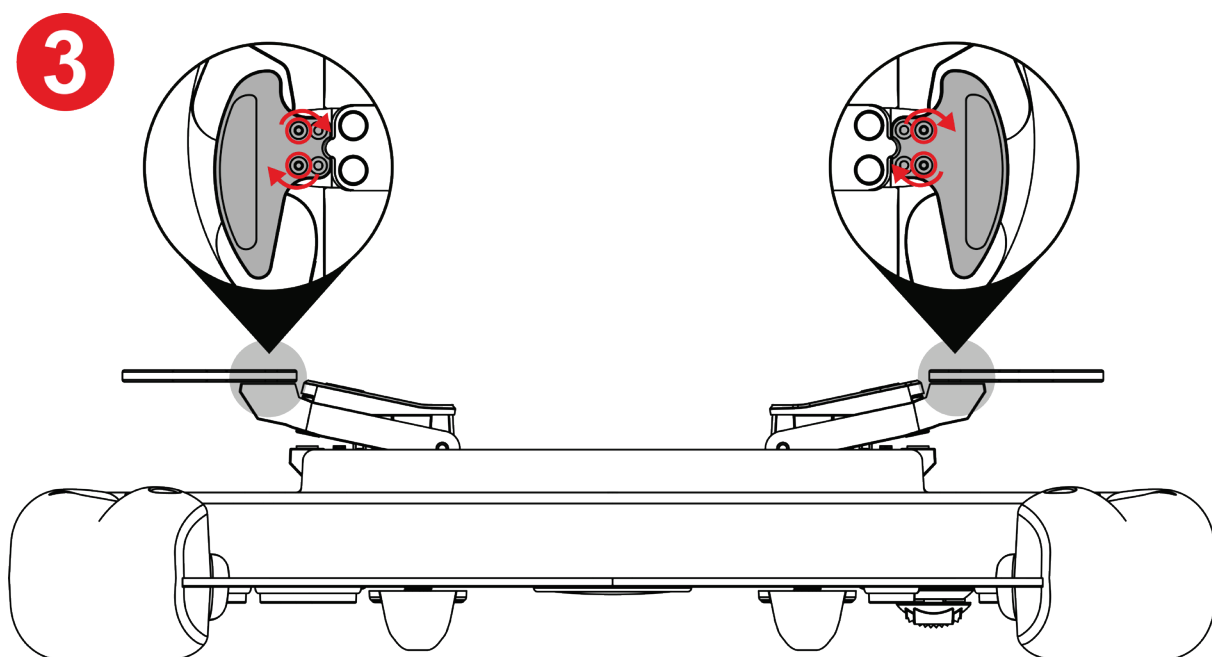

3 Aperte os quatro parafusos das patilhas de velocidades utilizando a chave Torx fornecida.



Como ajustar a sensibilidade magnética e o nível sonoro das patilhas de velocidades

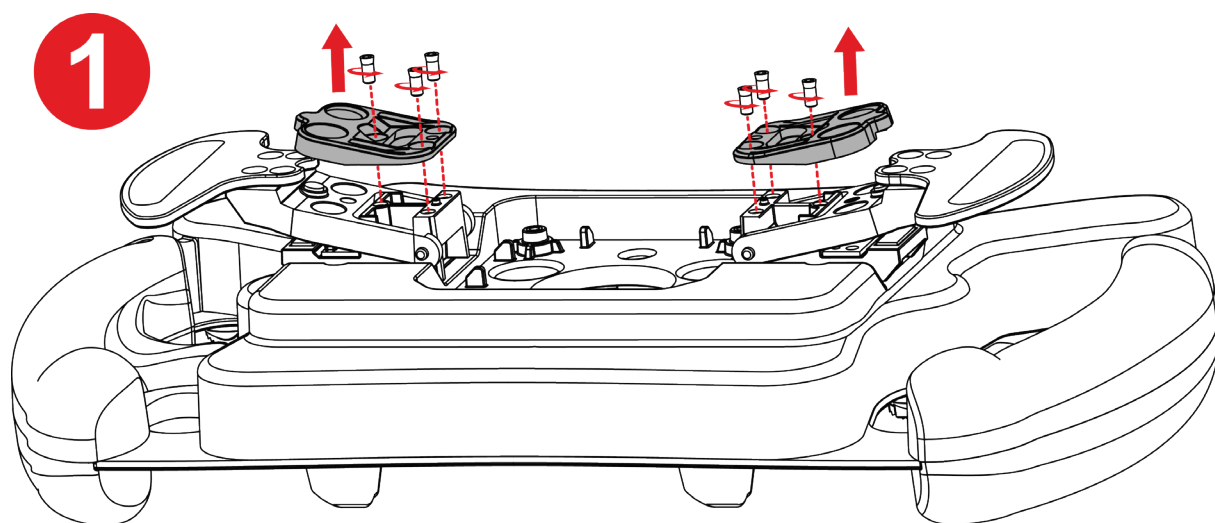

1 Remova os batentes magnéticos desapertando os seis parafusos de aperto com a chave Torx fornecida.

2

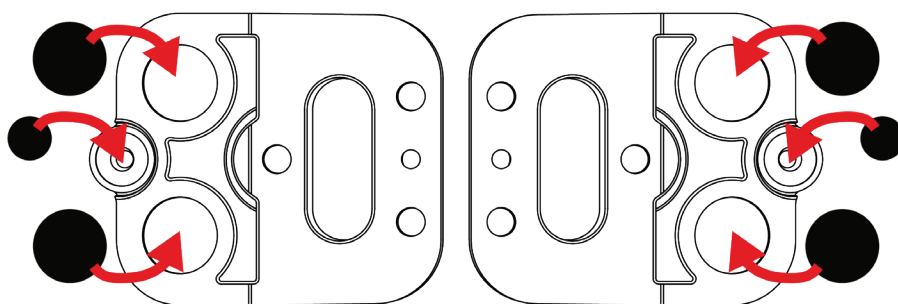
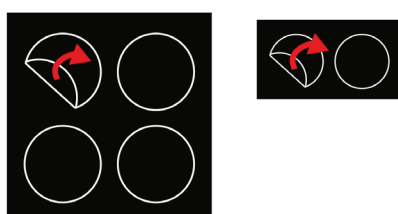

2 Destaque as almofadas de amortecimento e cole-as nas posições adequadas por baixo dos batentes magnéticos.



Consulte a **Tabela da sensibilidade magnética e de atenuação do som das patilhas de velocidades** sobre as configurações possíveis e respectivos efeitos.



3

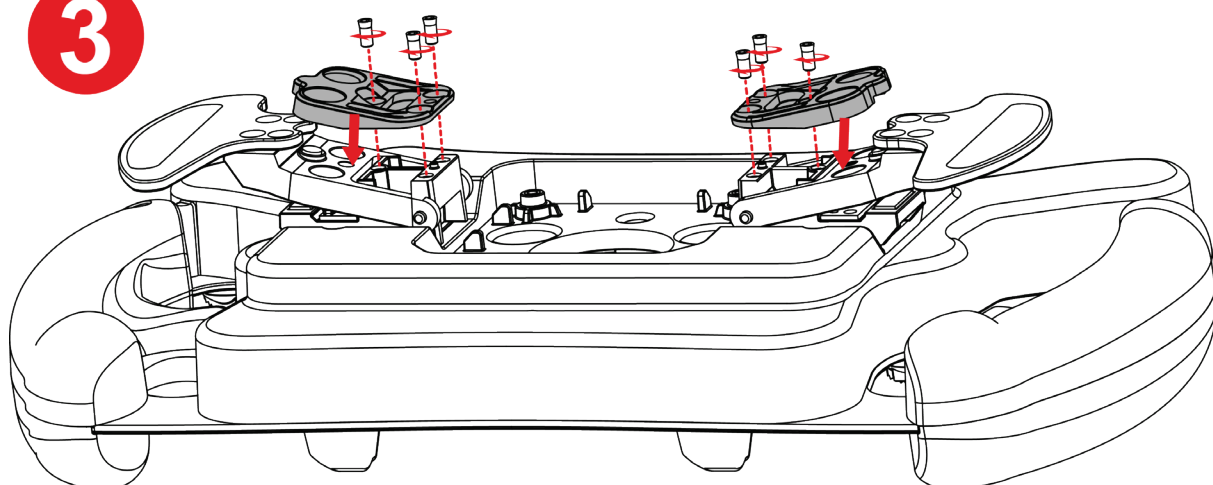

3 Reinstale os batentes magnéticos e aperte os seis parafusos de aperto com a chave Torx fornecida.

Tabela da sensibilidade magnética e de atenuação do som das patilhas de velocidades

	 (predefinição o)	 (predefinição o)	 (predefinição o)
Sensibilidade de magnética			
Som			



8. Perguntas frequentes e suporte técnico

Tem alguma questão relativamente ao Ferrari 488 GT3 Wheel Add-On, ou deparou-se com problemas técnicos? Se for o caso, visite o sítio Web de suporte técnico da Thrustmaster:

<https://support.thrustmaster.com/product/ferrarif488gt3addon>.

Nesta página também pode atualizar o firmware do volante.



THRUSTMASTER®

FERRARI 488 GT3 WHEEL ADD-ON

ПК (Windows 10/11)
PS4™ / PS5™
Xbox Series / Xbox One

Руководство пользователя



Внимательно прочитайте инструкции, содержащиеся в данном руководстве, **перед** установкой, **перед** любым использованием продукта и **перед** любым техническим обслуживанием. Обязательно соблюдайте правила техники безопасности. Несоблюдение техники безопасности может привести к несчастным случаям или повреждениям. Сохраните это руководство, чтобы иметь возможность обратиться к инструкциям в будущем.

СОДЕРЖАНИЕ

1.	СОДЕРЖИМОЕ КОРОБКИ	5
2.	ОПИСАНИЕ УСТРОЙСТВА.....	6
3.	ИНФОРМАЦИЯ ОБ ИСПОЛЬЗОВАНИИ РУЛЯ.....	8
4.	УСТАНОВКА БЫСТРОСЪЕМНОГО ДЕРЖАТЕЛЯ	13
	<i>Установка быстросъемного держателя для базы с креплением защелкой.....</i>	<i>14</i>
	<i>Установка быстросъемного держателя для винтовой базы</i>	<i>17</i>
5.	НАЗНАЧЕНИЕ КНОПОК	21
	<i>Назначение кнопок для ПК</i>	<i>21</i>
	<i>Назначение кнопок для PS4™/PS5™</i>	<i>22</i>
	<i>Назначение кнопок для Xbox Series/Xbox One</i>	<i>23</i>

6. РАБОТА СВЕТОДИОДНЫХ	
ИНДИКАТОРОВ	24
<i>Как войти в меню настройки</i>	
<i>светодиодов и выйти из него</i>	25
<i>Как регулировать яркость</i>	
<i>светодиодов.....</i>	27
<i>Как изменить режим работы</i>	
<i>светодиодов: GT3 или Formula</i>	28
7. РЕГУЛИРОВКА ПОДРУЛЕВЫХ	
ПЕРЕКЛЮЧАТЕЛЕЙ.....	29
<i>Как отрегулировать вынос</i>	
<i>подрулевого переключателя.....</i>	31
<i>Как отрегулировать высоту</i>	
<i>подрулевых переключателей.....</i>	33
<i>Как отрегулировать магнитную</i>	
<i>чувствительность и уровень звука</i>	
<i>при использовании подрулевых</i>	
<i>переключателей</i>	35
8. ЧАСТО ЗАДАВАЕМЫЕ ВОПРОСЫ И	
ТЕХНИЧЕСКАЯ ПОДДЕРЖКА.....	37



FERRARI 488 GT3 WHEEL ADD-ON

Присоединяйтесь к легендарным гонкам GT благодаря рулю Ferrari 488 GT3 Wheel Add-On, который был разработан для эффективного управления автомобилем и совместим со всеми базами гоночных рулей Thrustmaster.

С помощью этого руководства вы сможете правильно установить и пользоваться рулем Ferrari 488 GT3 Wheel Add-On. Прежде чем приступить к гонкам, внимательно прочитайте инструкцию и предупреждения: они помогут вам получить максимальное удовольствие от использования устройства.



1. Содержимое коробки

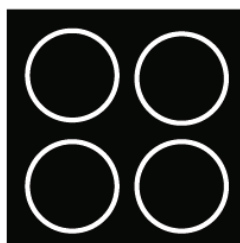
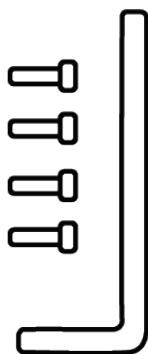
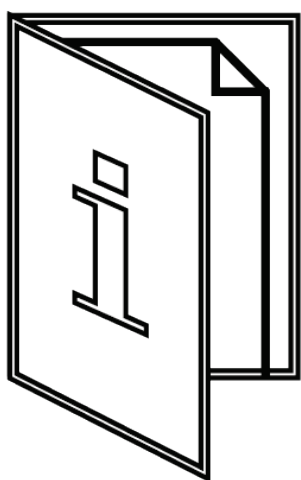
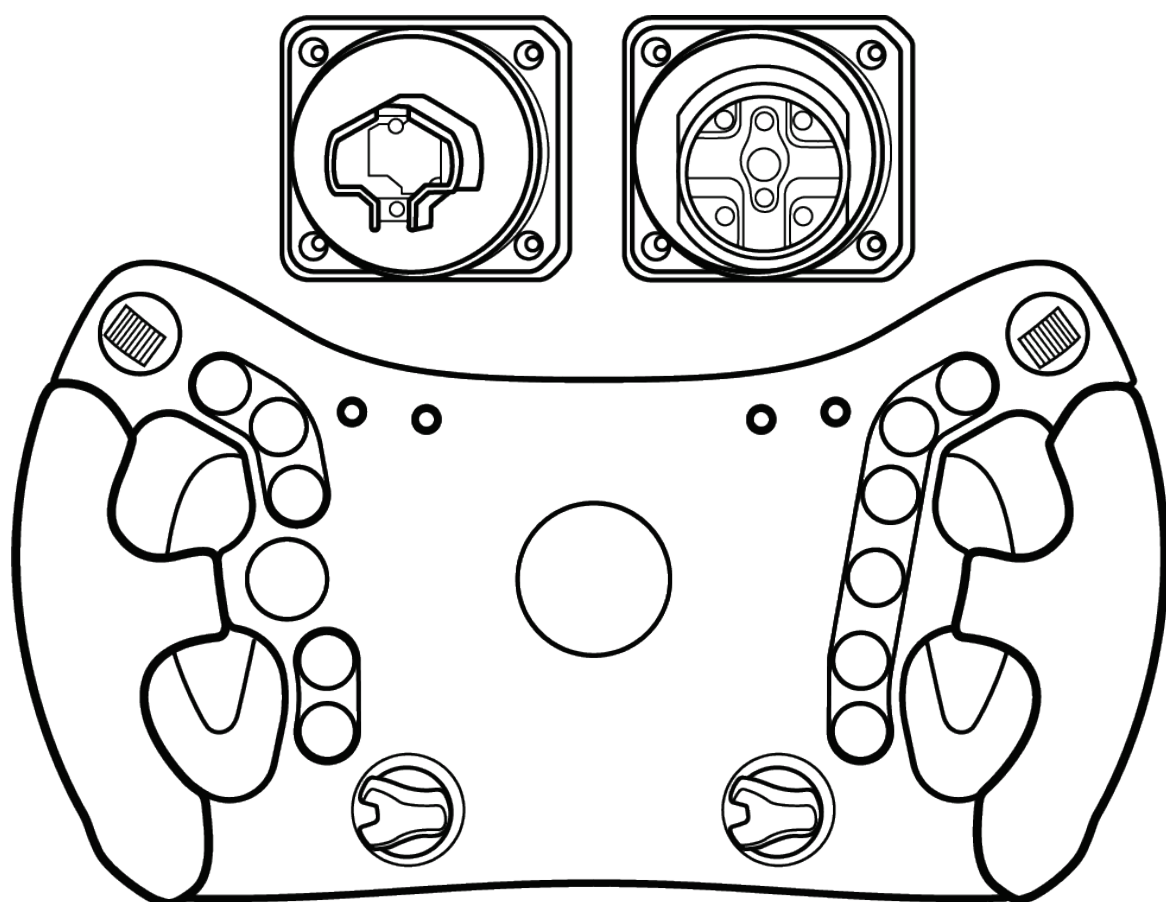



2. Описание устройства

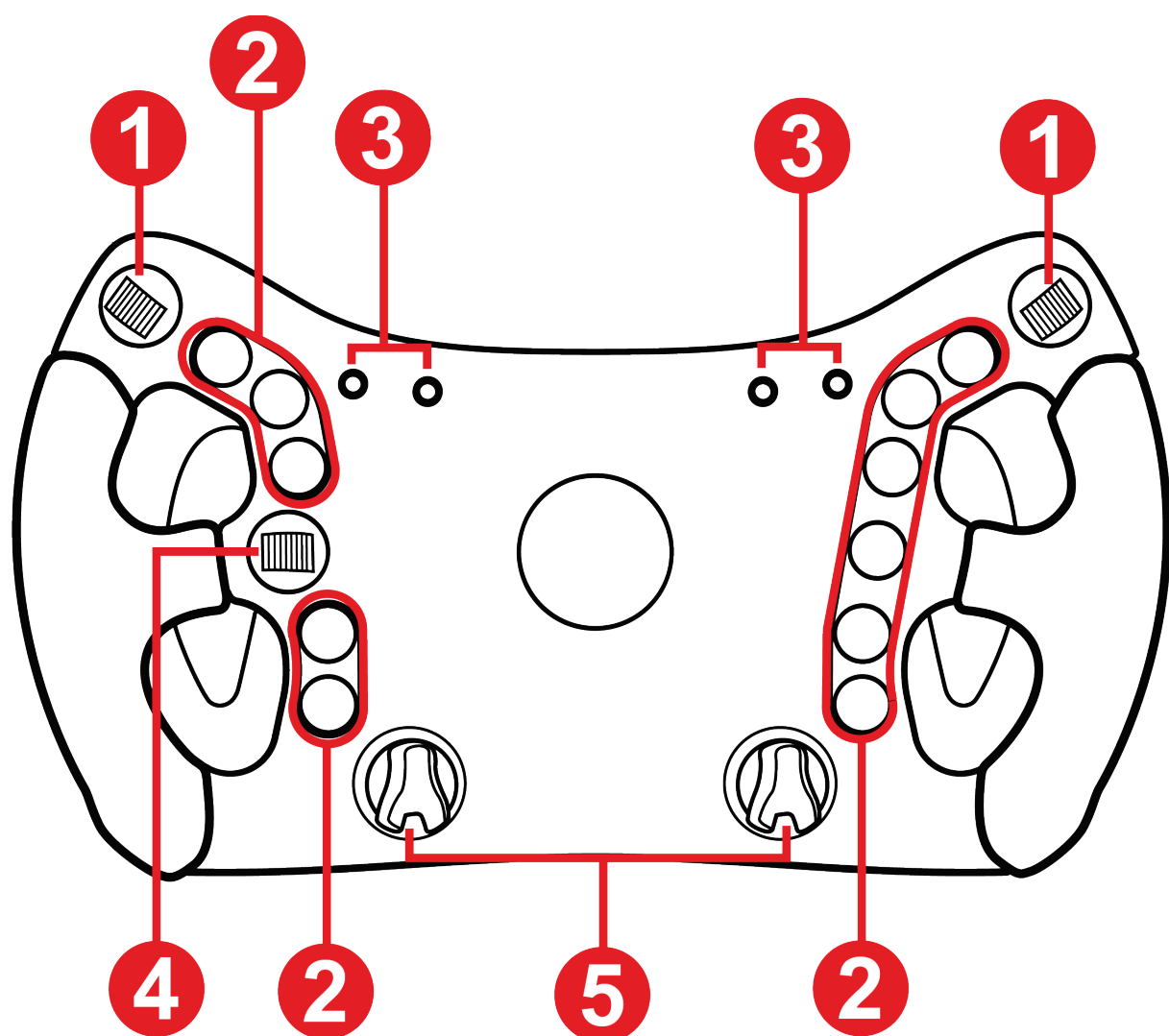

❶ Пальцевые регуляторы

❷ 11 командных кнопок

❸ Светодиодные индикаторы оборотов и гоночных данных (флаги, пит-стопы)

❹ Переключатель направления D-pad

❺ Поворотные регуляторы

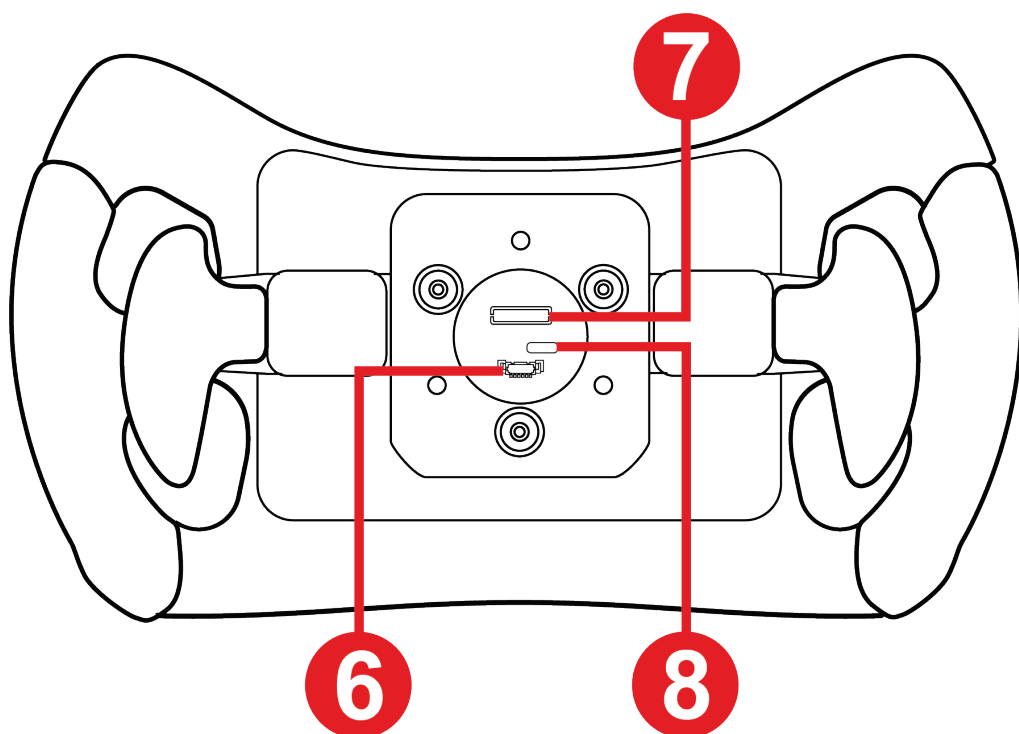

⑥ Порт подключения при использовании быстросъемного держателя для винтовой базы

⑦ Порт подключения при использовании быстросъемного держателя для базы с креплением защелкой

⑧ Порт USB-C (используется для обновления прошивки, кабель в комплект не входит)

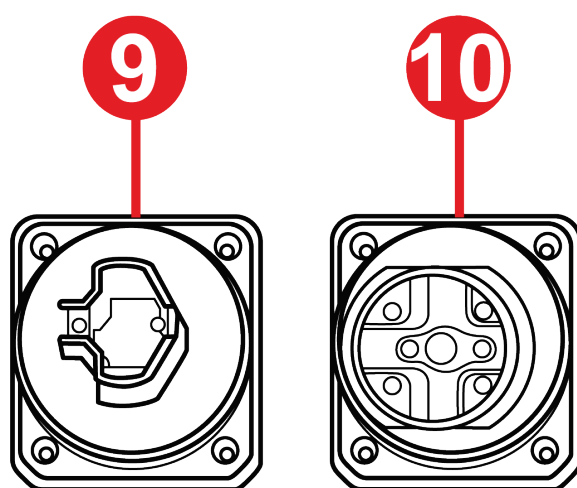

⑨ Быстросъемный держатель для базы с креплением защелкой

⑩ Быстросъемный держатель для винтовой базы



3. Информация об использовании руля



Документация

Прежде чем использовать приобретенное устройство, еще раз внимательно прочитайте данную инструкцию и сохраните ее, чтобы можно было обращаться к ней в будущем.



Поражение электрическим током

- Храните устройство в сухом месте и берегите его от воздействия пыли и солнечного света.
- Не перекручивайте разъемы и кабели и не тяните за них.
- Следуйте указаниям по подключению.
- Не допускайте попадания жидкости на устройство или его разъемы.
- Берегите устройство от короткого замыкания.
- Ни в коем случае не разбирайте устройство (за исключением случаев индивидуальной настройки, описанных в этом руководстве); берегите его от огня и от воздействия высоких температур.
- Не открывайте устройство: внутри нет деталей, предназначенных для обслуживания пользователем. Все ремонтные работы должны выполняться производителем, его официальным представителем или квалифицированным специалистом.



Безопасность игровой зоны

- Не ставьте в игровой зоне никаких предметов, которые могут помешать игроку или которые могут спровоцировать неловкое движение или вмешательство другого человека (например, чашка с кофе, телефон, ключи).
- Не закрывайте провода питания ковром, одеялом или любым другим настилом, не размещайте кабели в местах передвижения людей.



Травмирование в результате эффекта сопротивления и повторяющихся движений

Использование гоночного руля с эффектом сопротивления может вызвать боль в мышцах или суставах. Во избежание проблем:

- Делайте предварительную разминку и не пользуйтесь устройством слишком долго.
- После каждого часа игры делайте перерыв на 10–15 минут.
- Если вы чувствуете усталость или боль в кистях, запястьях, руках, ступнях или ногах, нажмите кнопку для отключения эффекта обратного сопротивления, выключите питание базы и отдохните несколько часов, прежде чем снова пользоваться устройством.
- Если вышеуказанные симптомы или боль сохраняются при возобновлении игры, прекратите играть и обратитесь к врачу.
- Не завышайте эффект сопротивления — устанавливайте значение, соответствующее вашему опыту и физическому состоянию.
- Храните устройство в месте, недоступном для лиц моложе 16 лет.



- Убедитесь, что база и руль закреплены правильно в соответствии с инструкциями данного руководства.



Опасность внезапного, сильного и быстрого вращения: никогда не просовывайте руки в отверстия на руле и не держите их на траектории его вращения.

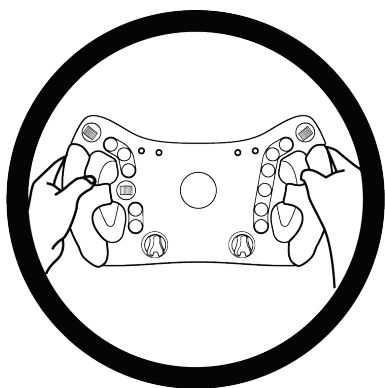

Во время использования всегда правильно располагайте обе руки на руле, никогда не отпускайте его полностью.



Это устройство предназначено исключительно для пользователей **старше 16 лет.**



4. Установка быстросъемного держателя

В комплект поставки руля **Ferrari 488 GT3 Wheel Add-On** входят два быстросъемных держателя для разных баз Thrustmaster.

Система	Совместимость
 <p>Быстросъемный держатель для базы с креплением защелкой</p>	T818, T818 Ferrari SF1000 Simulator и будущие базы Thrustmaster.
 <p>Быстросъемный держатель для винтовой базы</p>	T-GT / T-GT II Servo Base, T300 RS Servo Base, TS PC Racer, TS-XW, TX Racing Wheel Servo Base, TS-XW Servo Base.



Перед каждым использованием проверяйте, чтобы руль **Ferrari 488 GT3 Wheel Add-On** был правильно закреплен на опоре в соответствии с инструкциями к базе.



Установка быстросъемного держателя для базы с креплением защелкой

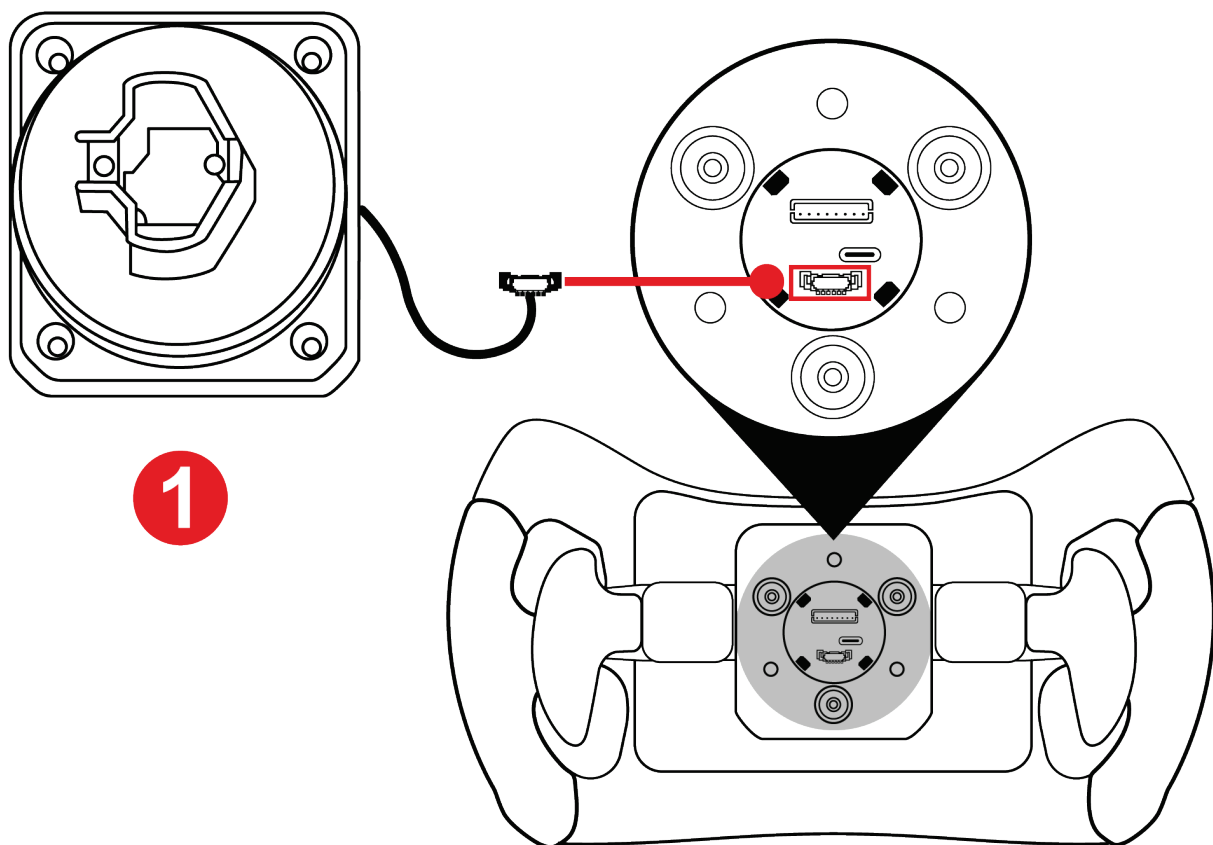

1

1 Подключите провод держателя к соответствующему порту на задней панели руля.



Чтобы не передавить провод, аккуратно уложите его внутри корпуса, прежде чем привинчивать держатель к рулю.

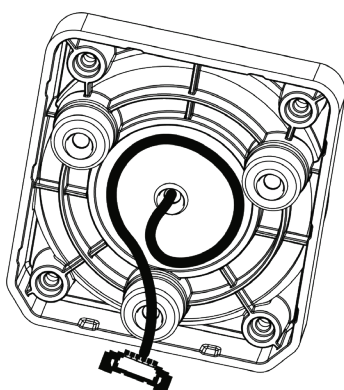

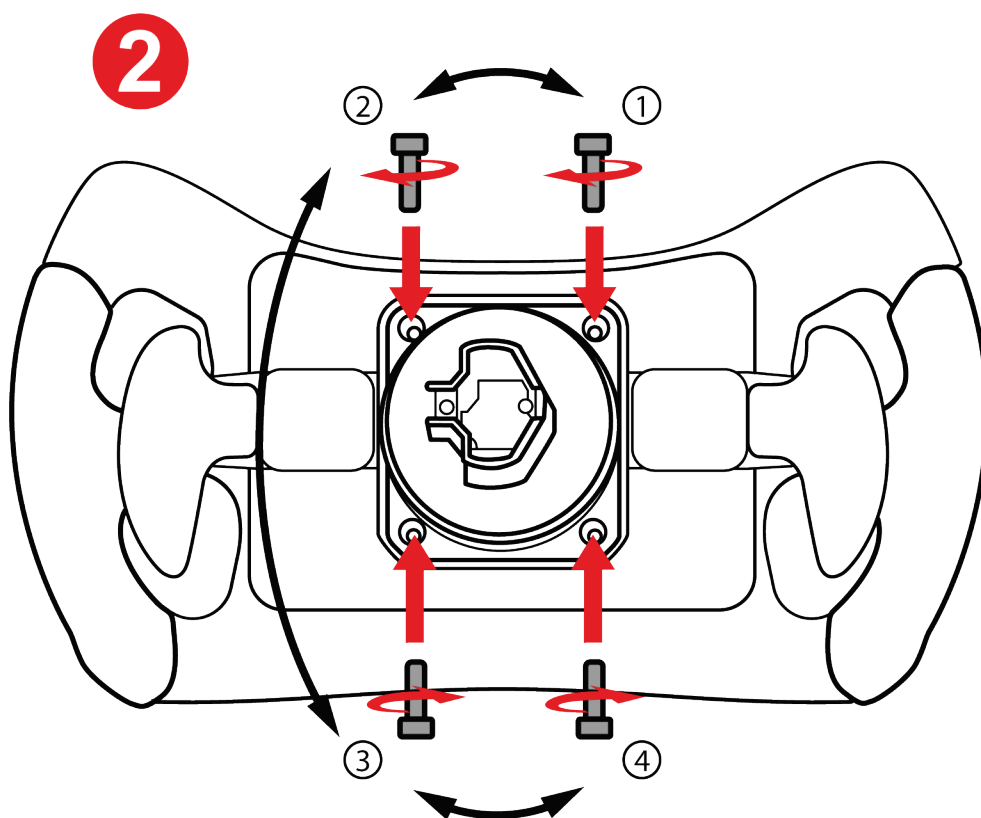

2 Установите быстросъемный держатель на место и затяните винты с помощью ключа Torx, который входит в комплект поставки.



Устанавливая держатель, не затягивайте винты слишком сильно.

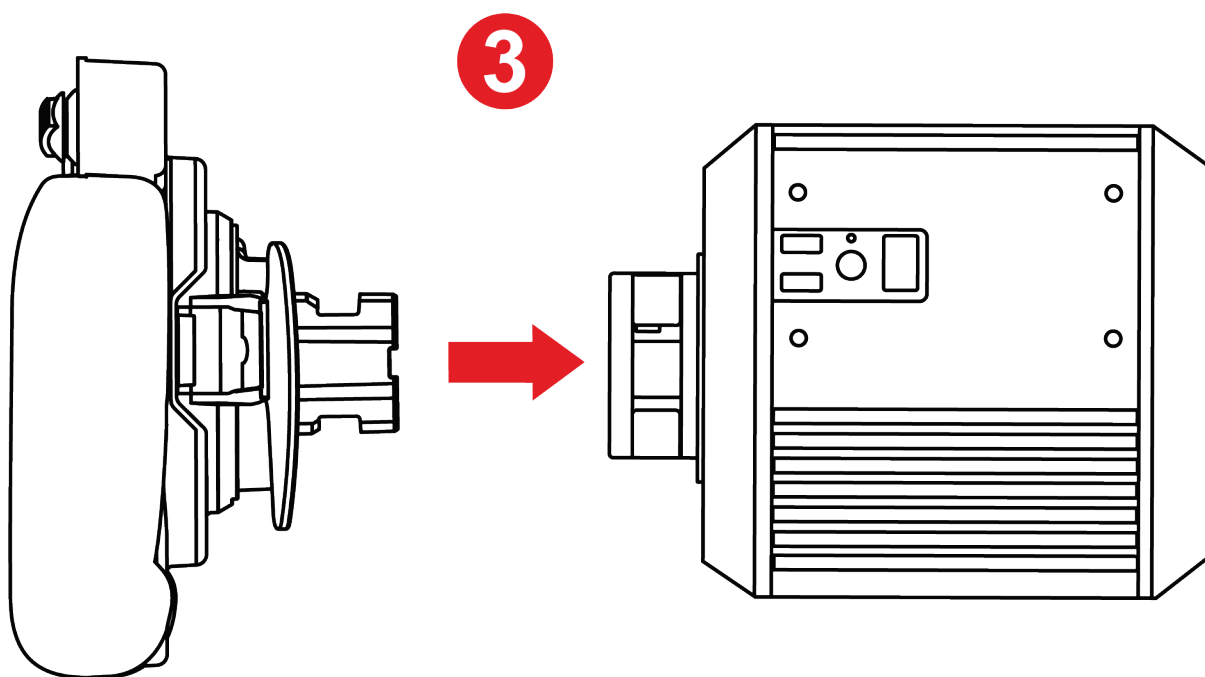

3 Установите руль на базу.



Следуйте инструкциям по установке в руководстве к рулевой базе.



Установка быстросъемного держателя для винтовой базы

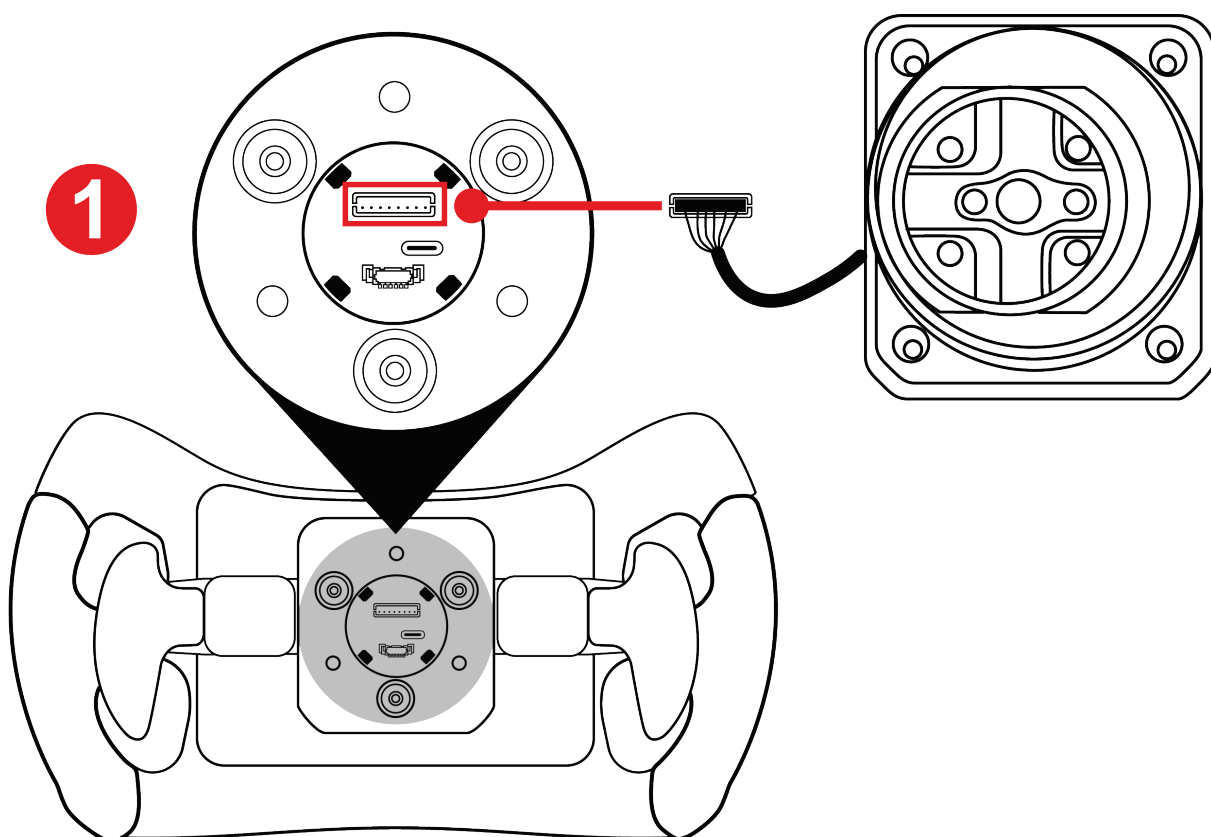

1 Подключите провод держателя к соответствующему порту на задней панели руля.



Чтобы не передавить провод, аккуратно уложите его внутри корпуса, прежде чем привинчивать держатель к рулю.

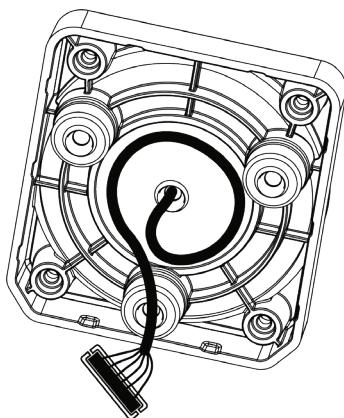

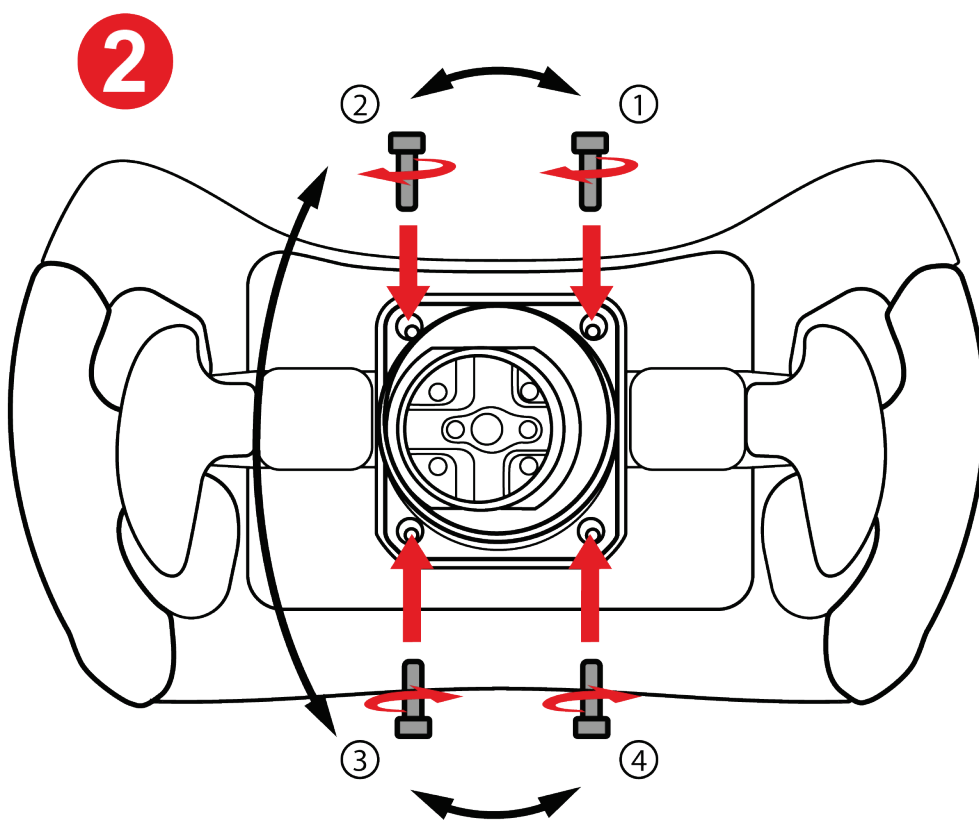

2 Установите быстросъемный держатель на место и затяните винты с помощью ключа Torx, который входит в комплект поставки.



Устанавливая держатель, не затягивайте винты слишком сильно.

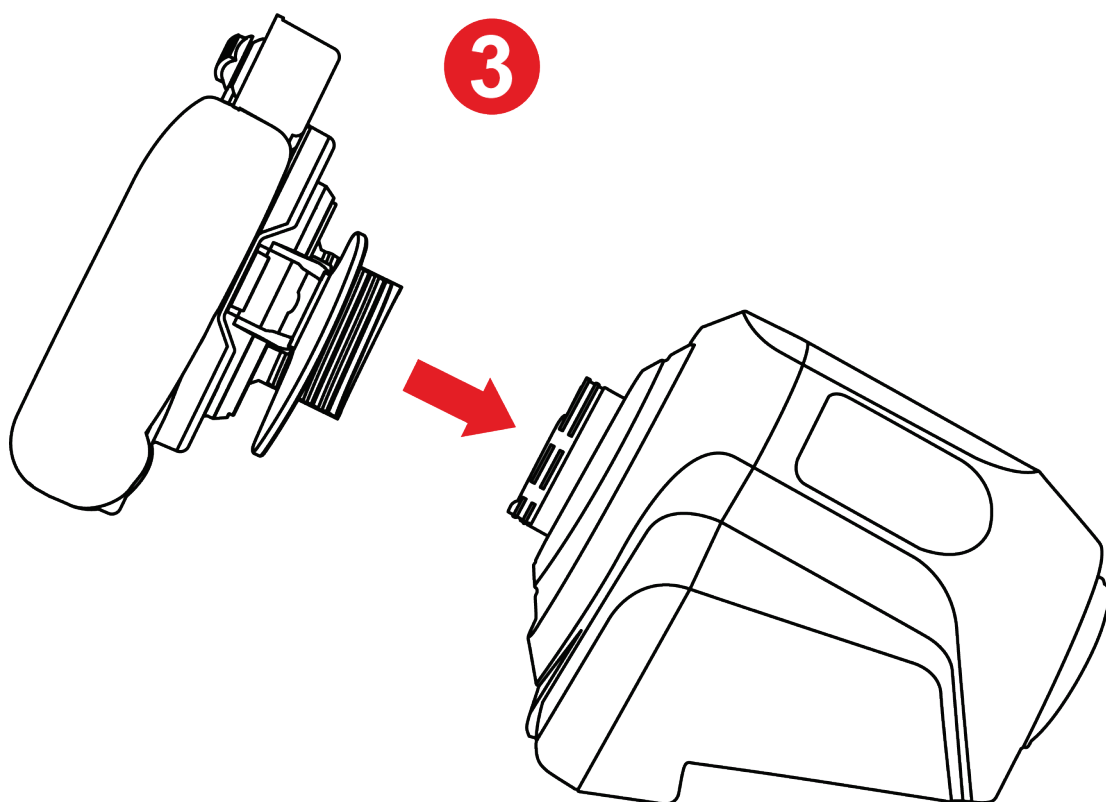

3 Установите руль на базу.



Следуйте инструкциям по установке в руководстве к рулевой базе.



Не используйте быстросъемный адаптер (поставляется вместе с базой T818 и продается отдельно) для крепления этой модели руля к базе T818.

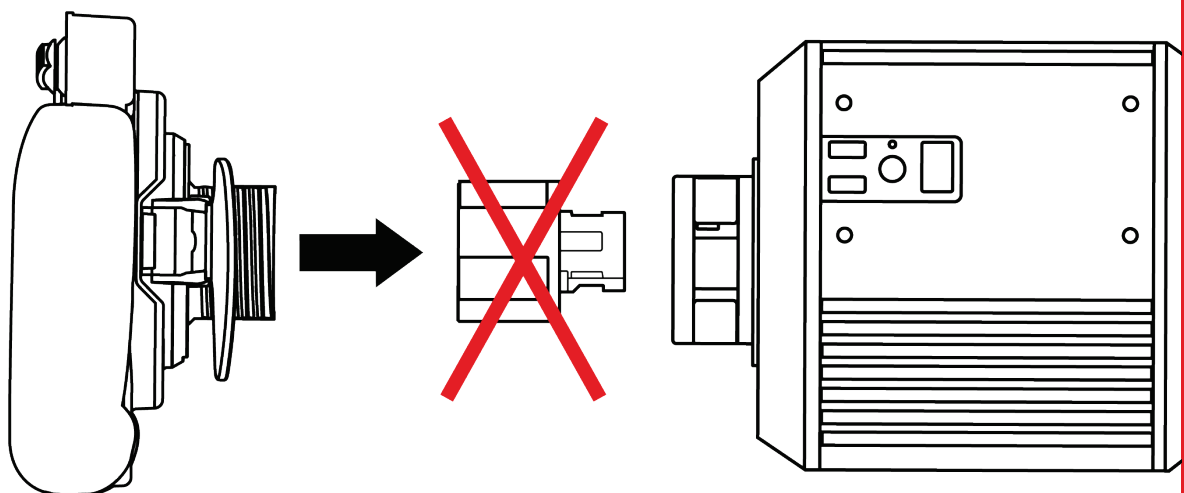
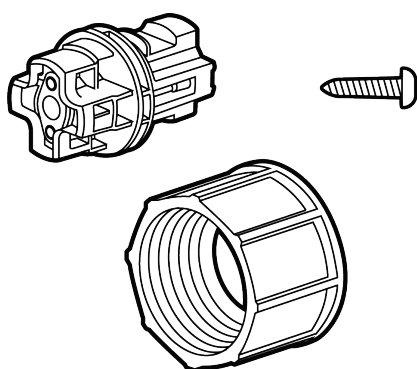

Если вы устанавливаете руль на базу T818 или другую базу с креплением защелкой, используйте только **быстросъемный держатель для базы с креплением защелкой**, который входит в комплект **Ferrari 488 GT3 Wheel Add-On**.



5. Назначение кнопок

Назначение кнопок для ПК

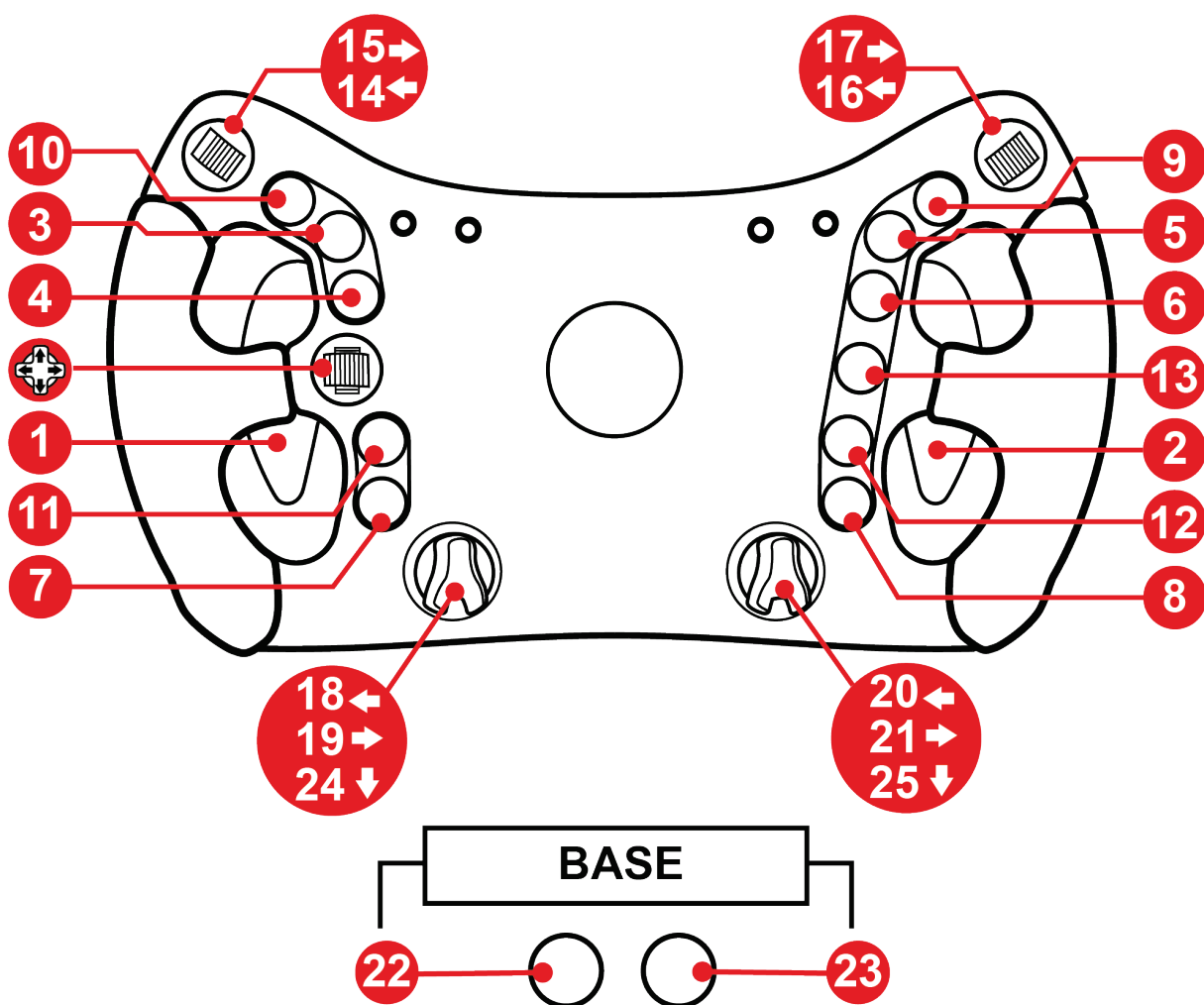



Назначение кнопок для PS4™/PS5™

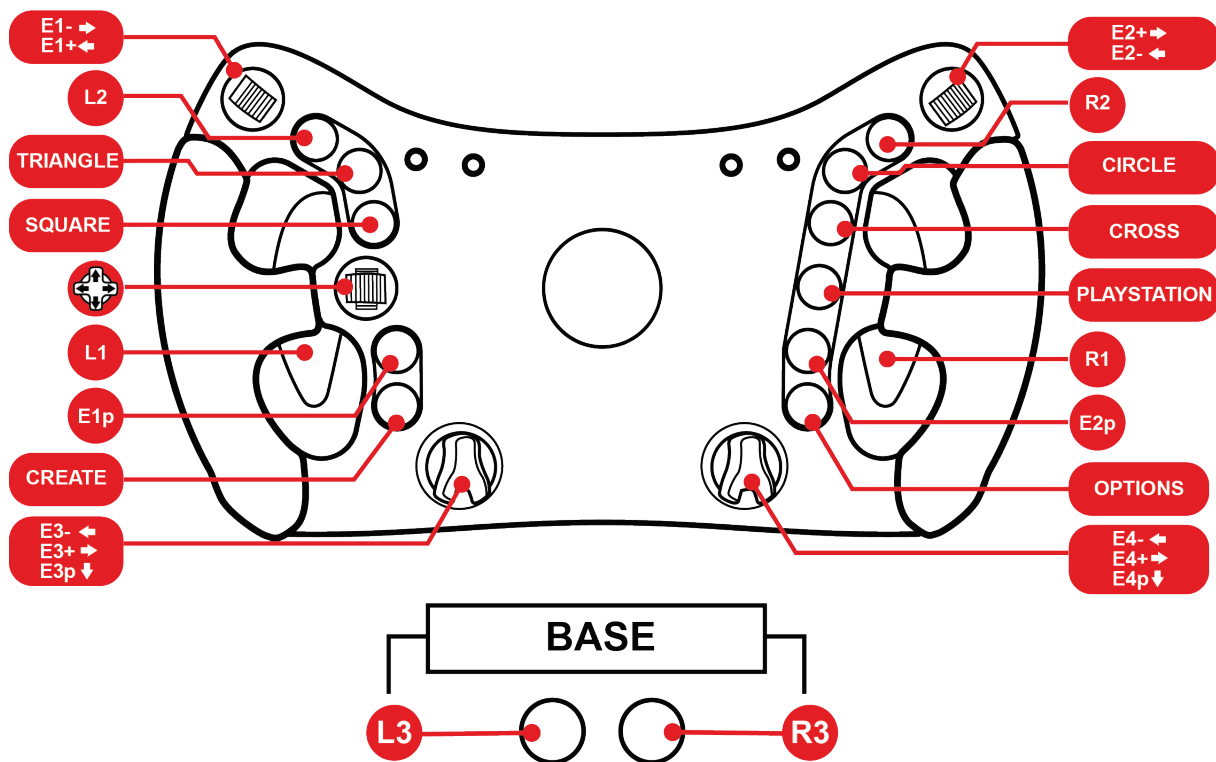



Назначение кнопок для Xbox Series/Xbox One

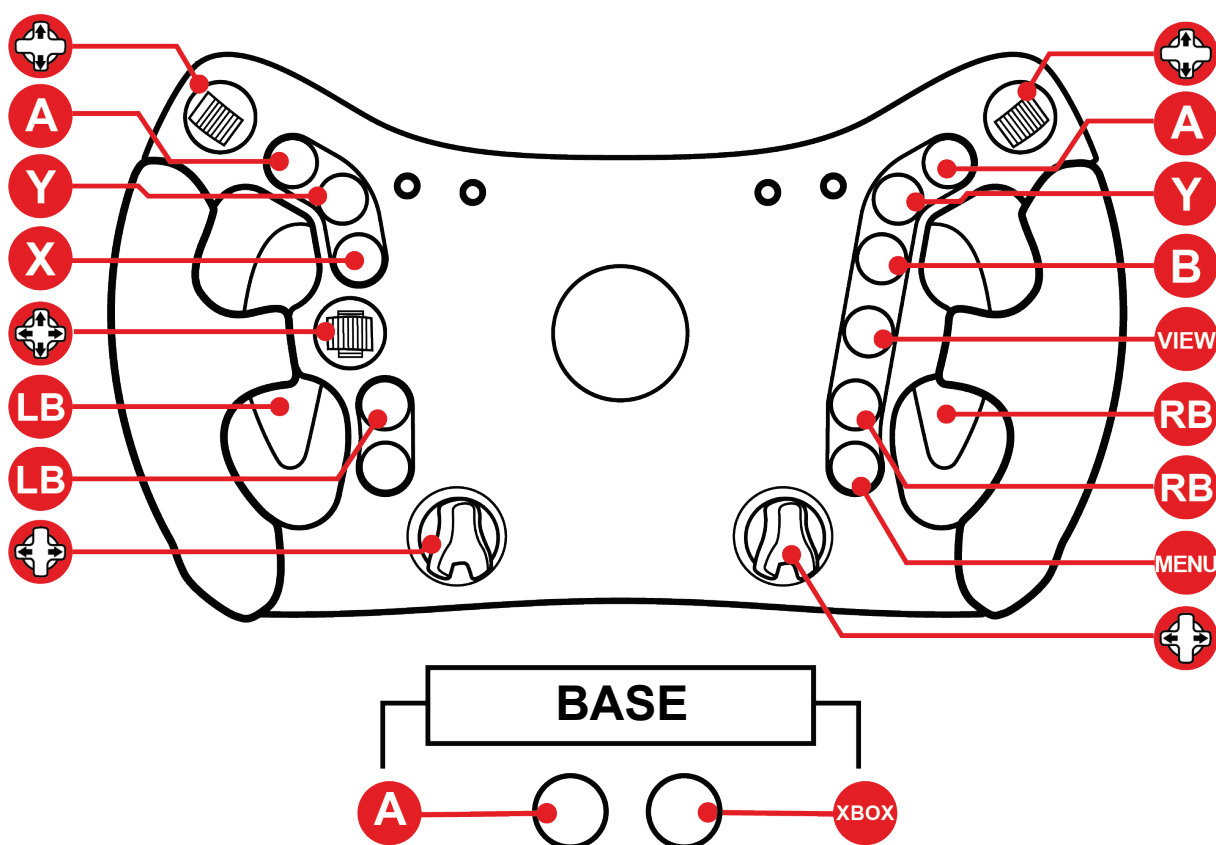

На Xbox Series и Xbox One:

- Светодиодные индикаторы на руле Ferrari 488 GT3 Wheel Add-On не работают из-за ограничений протокола консоли.
- Некоторые функции (регуляторы, количество кнопок) ограничены протоколом консоли.



6. Работа светодиодных индикаторов

На руле **Ferrari 488 GT3 Wheel Add-On** некоторые гоночные сведения отображаются с помощью светодиодных индикаторов: флаги, пит-стопы и обороты.

Отображение данных (интенсивность и цвет светодиодных индикаторов оборотов) можно настраивать в зависимости от режима гонок (GT3 или Formula).

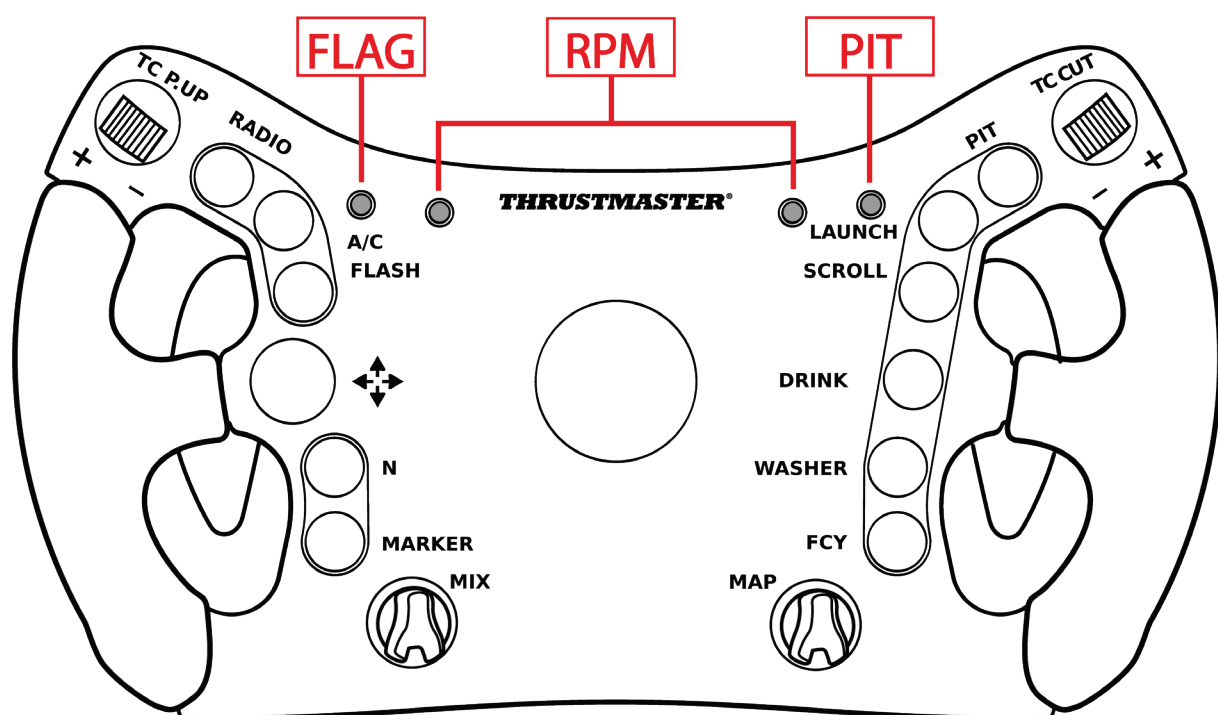

Светодиодные индикаторы работают, если устройство подключено к ПК или PS4™/PS5™.

На Xbox Series и Xbox One они не работают из-за ограничений протокола консоли.



Как войти в меню настройки светодиодов и выйти из него

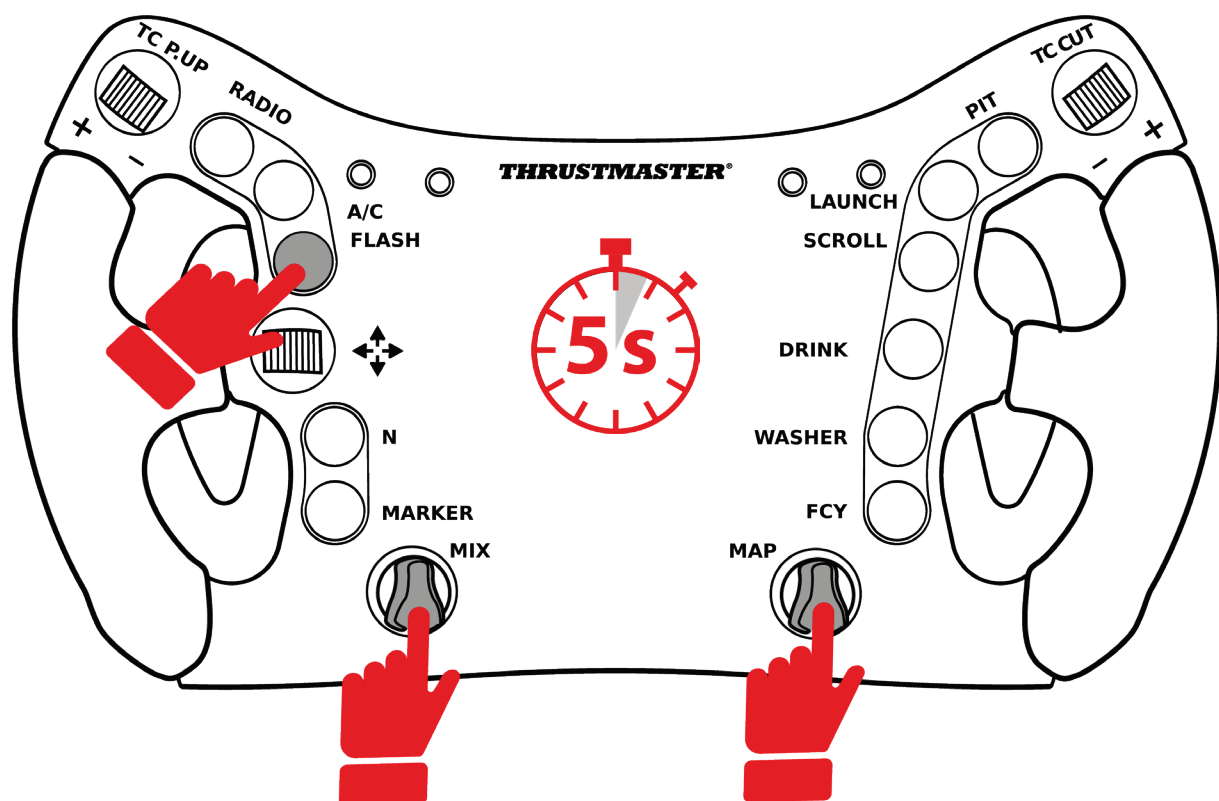

- Для входа в меню настройки светодиодных индикаторов одновременно нажмите кнопку **FLASH** и оба поворотных регулятора, удерживайте их в течение **5 секунд**, а затем отпустите.
- Для выхода из меню настройки светодиодных индикаторов одновременно нажмите кнопку **FLASH** и оба поворотных регулятора, а затем отпустите.



FLAG

RPM

PIT



Когда вы находитесь в меню светодиодов, три из них светятся: FLAG, PIT и один из индикаторов оборотов (красный слева или синий справа).



Когда вы выходите из меню настройки светодиодов, все четыре светодиода гаснут.



Как регулировать яркость светодиодов

- Для входа в меню настройки светодиодных индикаторов одновременно нажмите кнопку **FLASH** и оба **поворотных регулятора**, удерживайте их в течение 5 секунд, а затем отпустите.
- Поверните **левый регулятор (MIX)** влево для уменьшения яркости или вправо для увеличения яркости.



- Для выхода из меню настройки светодиодных индикаторов одновременно нажмите кнопку **FLASH** и оба **поворотных регулятора**, а затем отпустите.



Как изменить режим работы светодиодов: GT3 или Formula

- Для входа в меню настройки светодиодных индикаторов одновременно нажмите кнопку **FLASH** и оба поворотных регулятора, удерживайте их в течение 5 секунд, а затем отпустите.
- Поверните правый регулятор (MAP) влево для выбора режима GT3 (красный светодиод) или вправо для выбора режима Formula (синий светодиод).



Режим GT3 (по умолчанию)



Режим FORMULA

- Для выхода из меню настройки светодиодных индикаторов одновременно нажмите кнопку **FLASH** и оба поворотных регулятора, а затем отпустите.



7. Регулировка подрулевых переключателей

На руле **Ferrari 488 GT3 Wheel Add-On** можно регулировать **вынос** и **высоту** подрулевых переключателей.

Регулировка **выноса** заключается в том, что вы либо раздвигаете, либо сдвигаете подрулевые переключатели, то есть меняете расстояние между краями руля и краями переключателей.

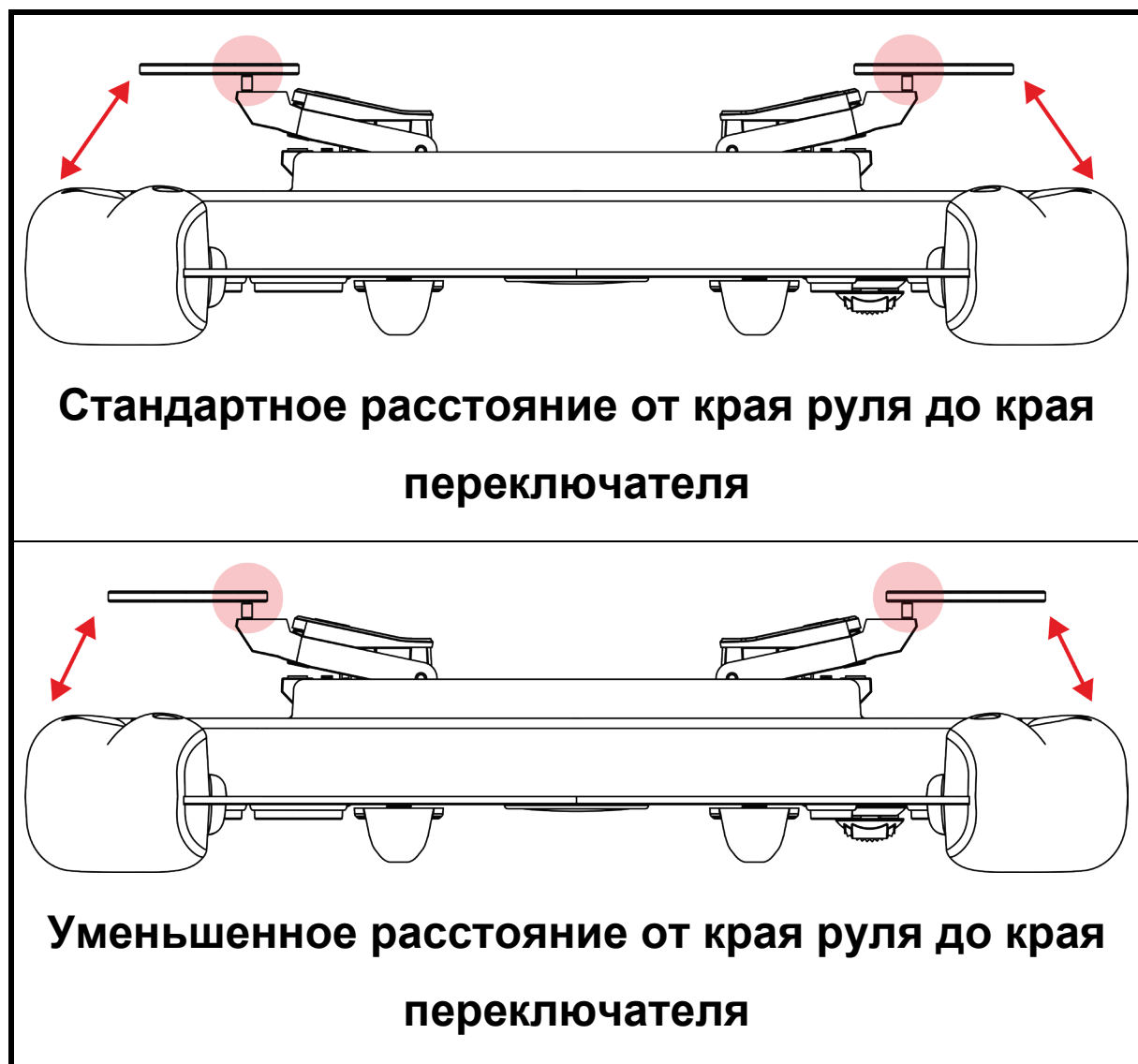



Регулируя **высоту** с помощью специальных вкладышей, вы меняете расстояние срабатывания переключателя.

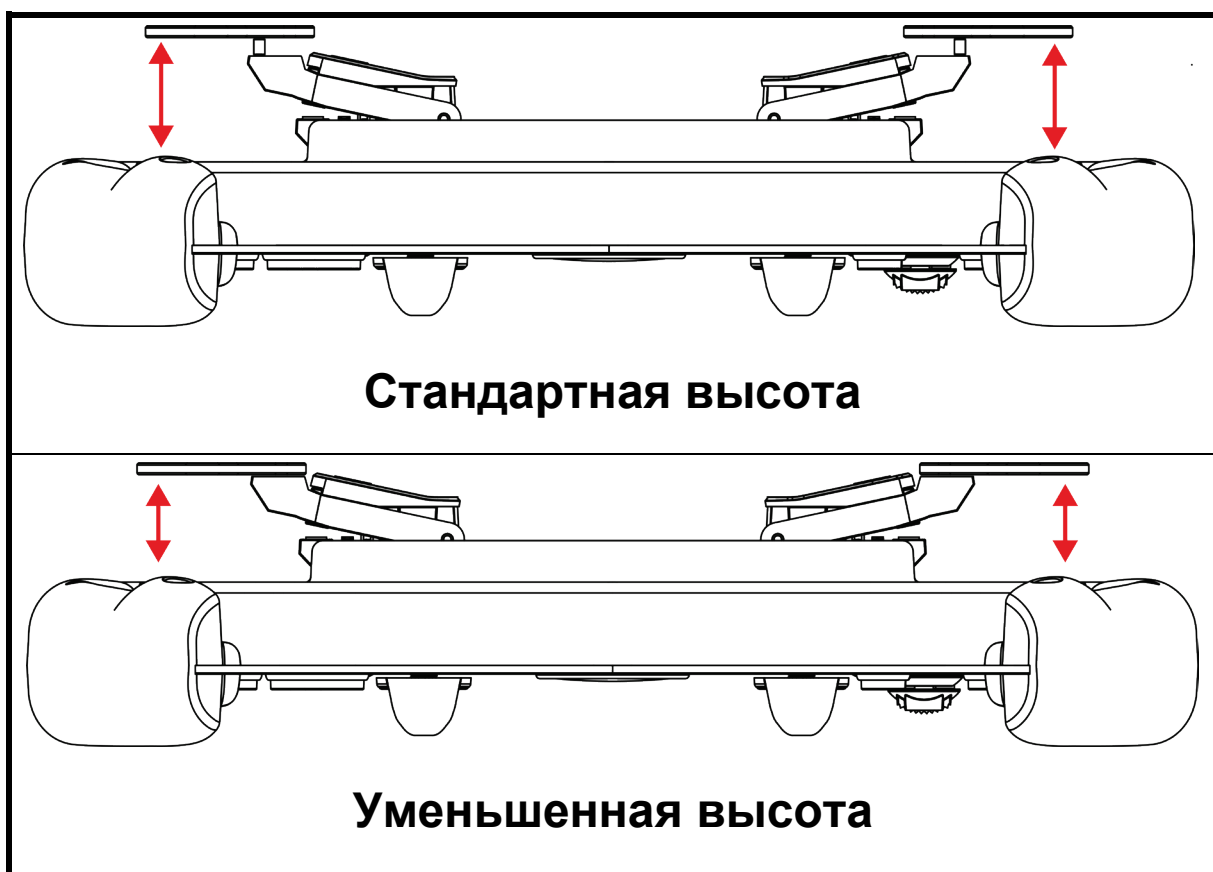

Также с помощью накладок, входящих в комплект поставки, можно регулировать **магнитную чувствительность** и **громкость звука**, издаваемого подрулевыми переключателями.

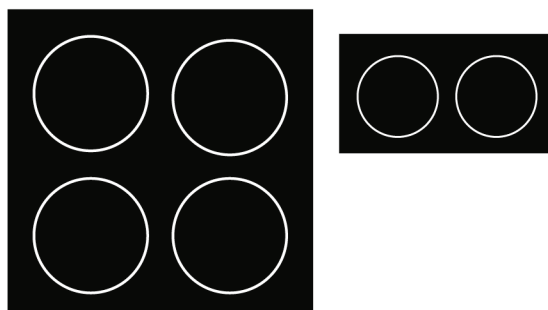



Как отрегулировать вынос подрулевого переключателя

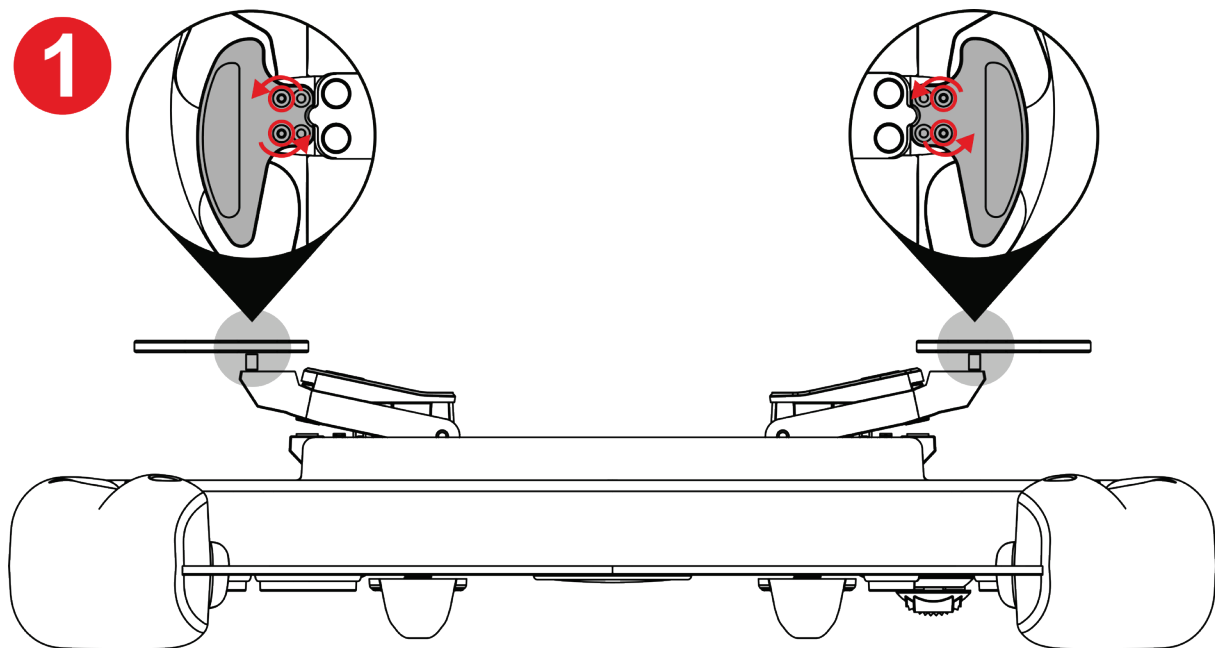

1 Открутите четыре винта на подрулевом переключателе с помощью ключа Torx, входящего в комплект поставки.

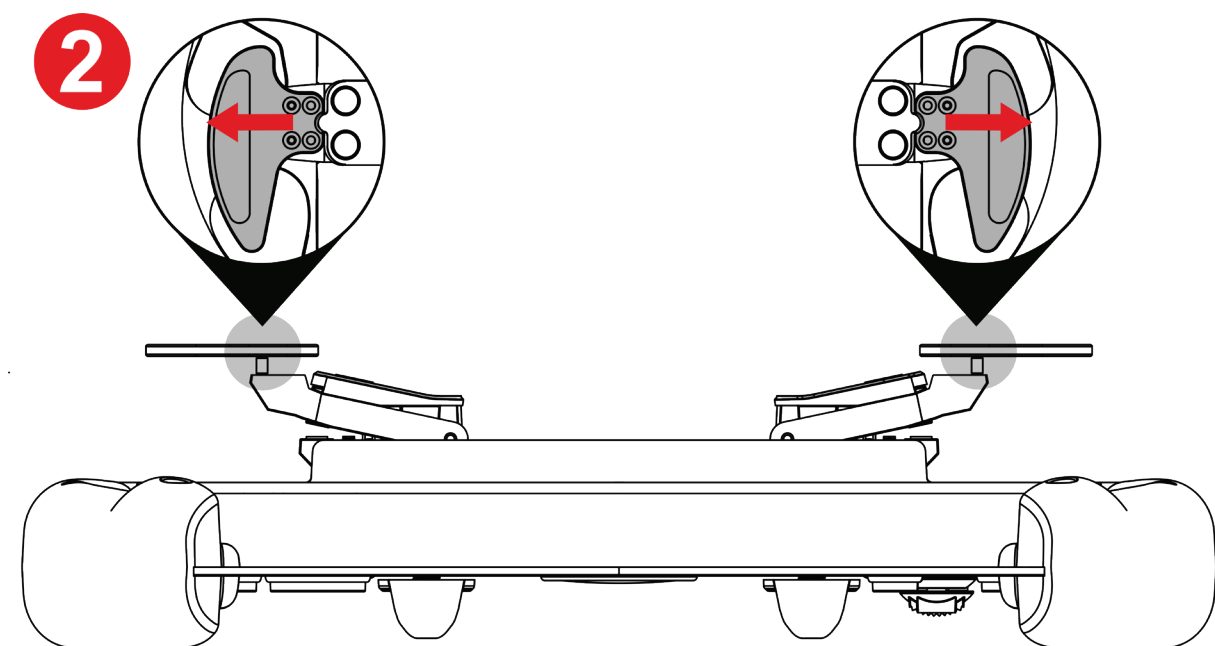

2 Сместите подрулевые переключатели вовне, следя за тем, чтобы отверстия для винтов совпали.

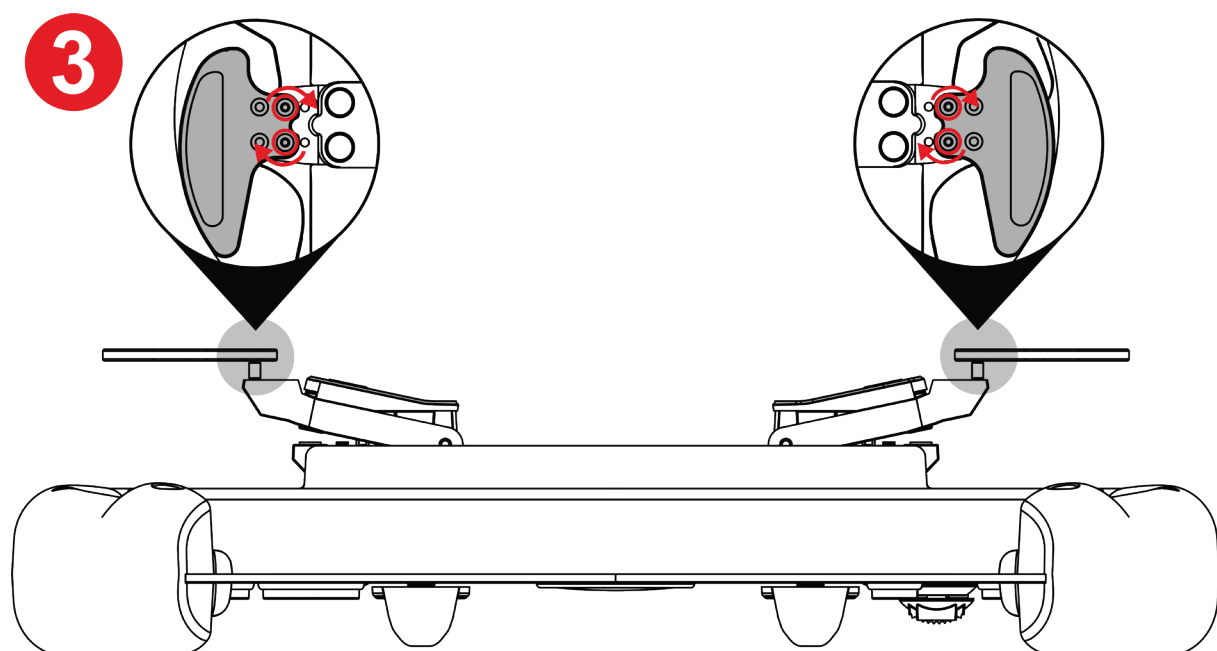

3 Закрутите четыре винта на подрулевом переключателе с помощью ключа Torx, входящего в комплект поставки.



Как отрегулировать высоту подрулевых переключателей

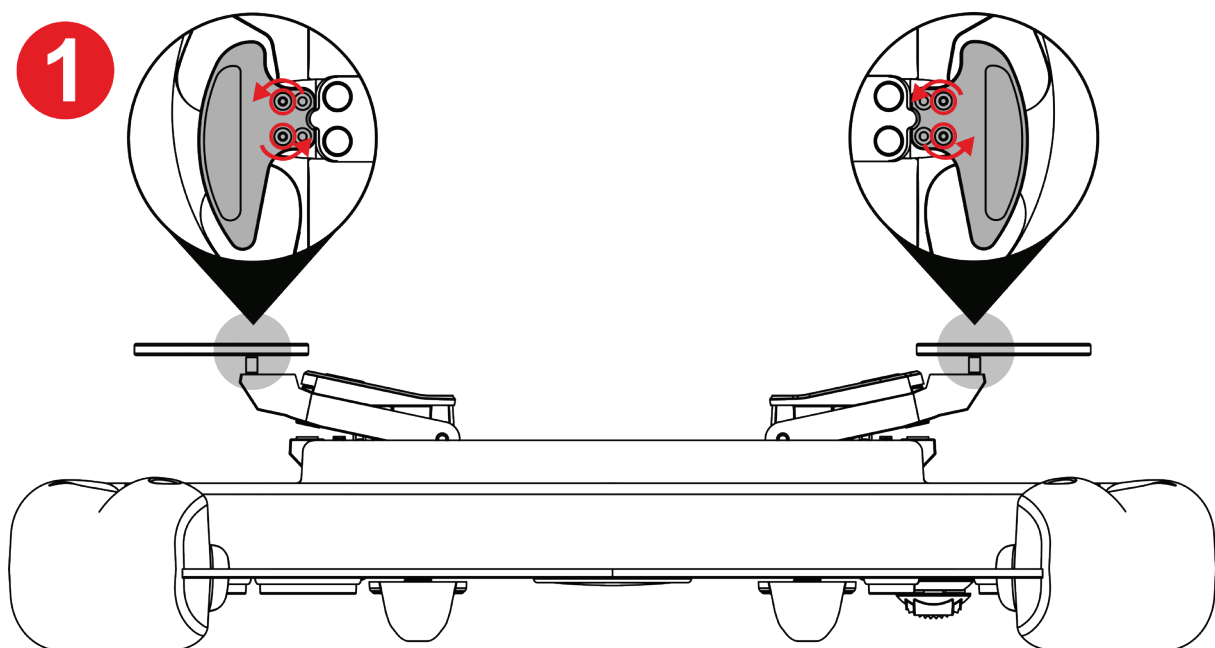

1 Открутите четыре винта на подрулевом переключателе с помощью ключа Torx, входящего в комплект поставки.

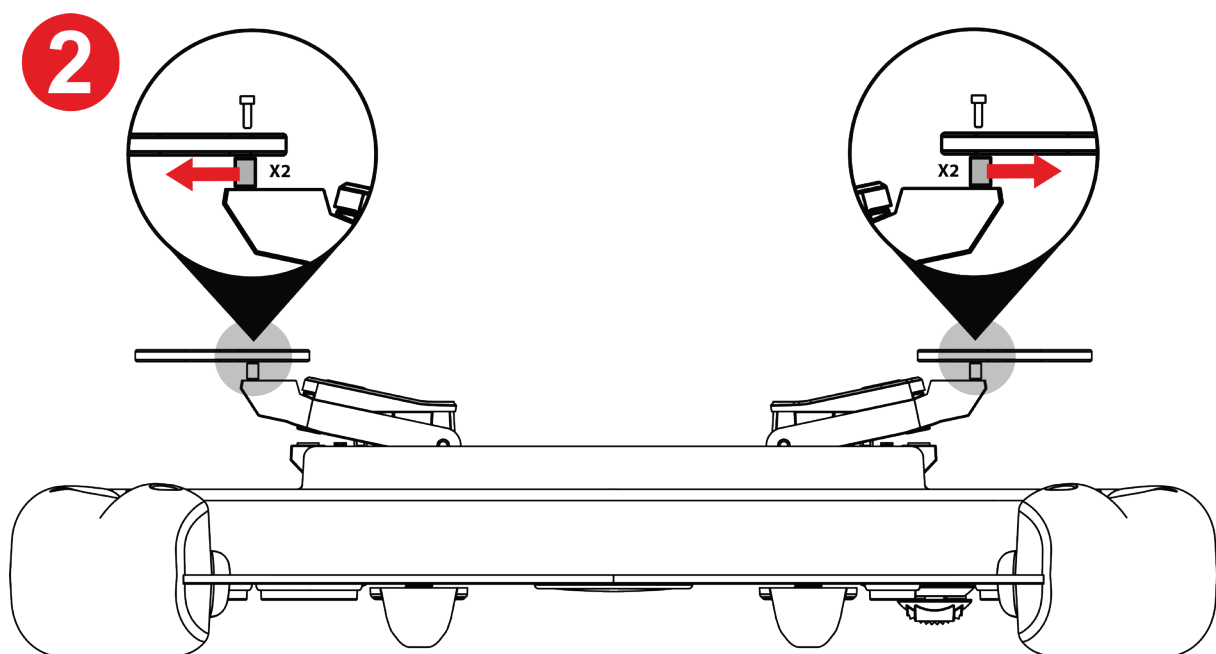

2 Снимите вкладыши.

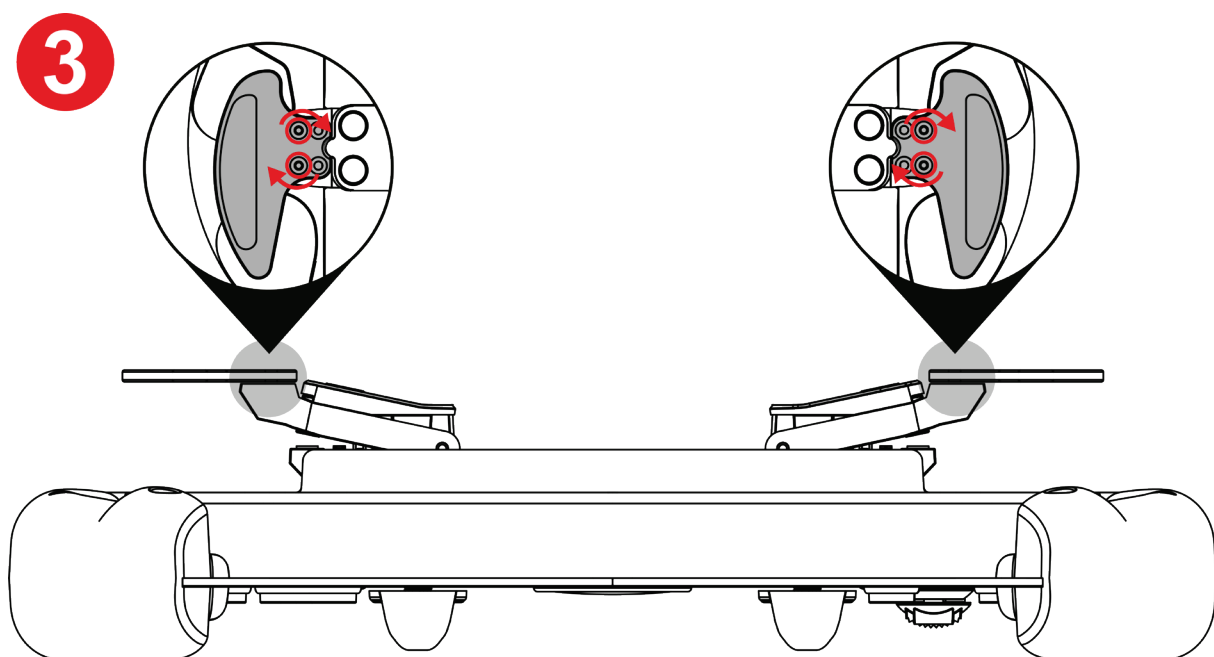

3 Закрутите четыре винта на подрулевом переключателе с помощью ключа Torx, входящего в комплект поставки.



Как отрегулировать магнитную чувствительность и уровень звука при использовании подрулевых переключателей

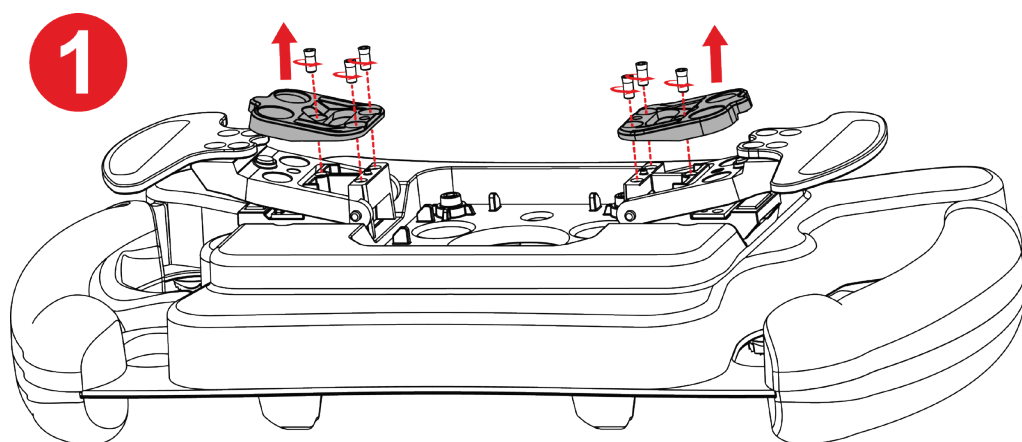

1 Снимите магнитные упоры, открутив шесть винтов с помощью ключа Torx, входящего в комплект поставки.

2

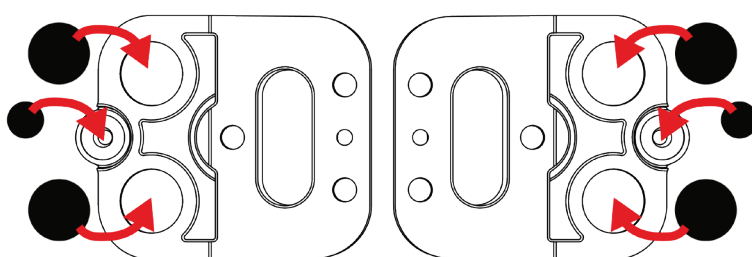
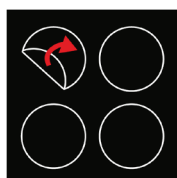

2 Отклейте наклейки, входящие в комплект, и приклейте их под магнитными упорами — в местах, обозначенных стрелками.



Возможные комбинации накладок и результаты их применения описаны в таблице **Снижение магнитной чувствительности и уровня звука при использовании подрулевых переключателей.**



3

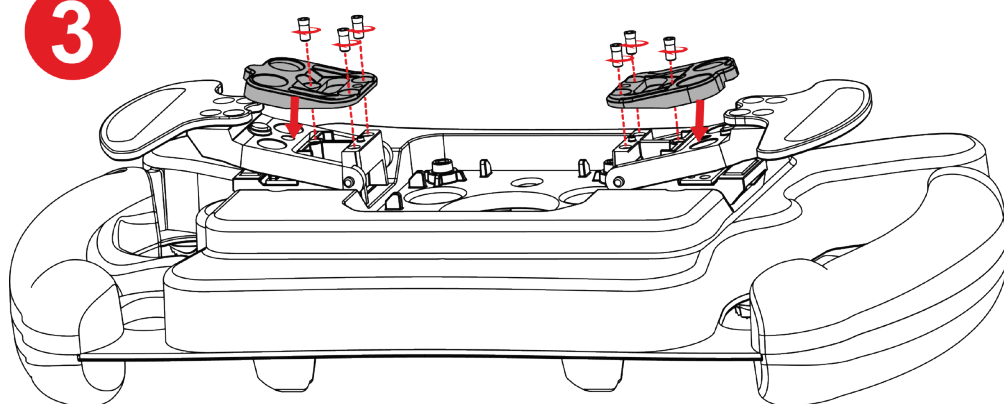

3 Установите на место магнитные упоры и затяните шесть винтов с помощью ключа Torx, входящего в комплект поставки.

Снижение магнитной чувствительности и уровня звука при использовании подрулевых переключателей

	<p>(стандартная настройка)</p>	<p>(стандартная настройка)</p>	<p>(стандартная настройка)</p>
Магнитная чувствительность			
Звук			



8. Часто задаваемые вопросы и техническая поддержка

У вас есть вопросы по Ferrari 488 GT3 Wheel Add-On или возникли технические проблемы? Посетите веб-сайт технической поддержки Thrustmaster:

<https://support.thrustmaster.com/product/ferrarif488gt3addon>.

На этой странице можно также обновить прошивку руля.



THRUSTMASTER®

FERRARI 488 GT3 WHEEL ADD-ON

PC (Windows 10/11)

PS4™ / PS5™

Xbox Series / Xbox One

Uživatelský manuál



Před instalací výrobku, **před** jakýmkoli použitím výrobku a **před** jakoukoli údržbou si **pečlivě přečtete** pokyny uvedené v této příručce. Nezapomeňte dodržovat bezpečnostní pokyny. Nedodržení těchto pokynů může mít za následek nehody a/nebo poškození. Tento návod si uschovejte, abyste se k němu mohli v budoucnu vrátit

OBSAH

1.	OBSAH BALENÍ	5
2.	FUNKCE.....	6
3.	INFORMACE O POUŽÍVÁNÍ VOLANTU.....	8
4.	INSTALACE RYCHLOUPÍNACÍHO DRŽÁKU	13
	<i>Instalace rychloupínacího držáku pro základnu se západkou</i>	<i>14</i>
	<i>Instalace rychloupínacího držáku pro základnu se šroubem.....</i>	<i>17</i>
5.	MAPOVÁNÍ	21
	<i>Mapování pro PC</i>	<i>21</i>
	<i>Mapování pro PS4™/PS5™</i>	<i>22</i>
	<i>Mapování pro Xbox Series/Xbox One</i>	<i>23</i>
6.	PROVOZ LED DIOD	24
	<i>Jak vstoupit do nabídky LED nebo ji opustit.....</i>	<i>25</i>
	<i>Jak nastavit intenzitu LED.....</i>	<i>27</i>

Jak změnit režim LED: GT3 nebo

Formula28

7. PŘIZPŮSOBENÍ ŘADICÍCH PÁK29

Jak nastavit rozteč řadicích pák31

Jak nastavit dosah řadicí páky33

Jak nastavit magnetickou citlivost a

úroveň zvuku řadicích pák35

8. ČASTO KLADENÉ DOTAZY A TECHNICKÁ

PODPORA37



FERRARI 488 GT3 WHEEL ADD-ON

Staňte se součástí legendárních závodů GT s Ferrari 488 GT3 Wheel Add-On, volantem navrženým pro výkon a kompatibilním se všemi základnami Thrustmaster.

Tato příručka vám pomůže nainstalovat a používat váš Ferrari 488 GT3 Wheel Add-On za nejlepších podmínek. Než se pustíte do závodění, pečlivě si přečtěte návod a upozornění: pomohou vám získat z výrobku co nejvíce radosti..



1. Obsah balení

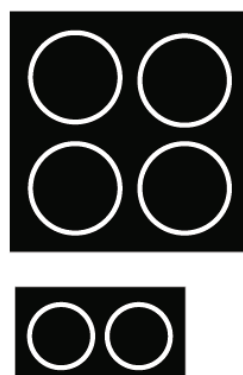
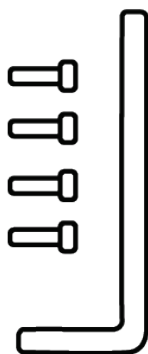
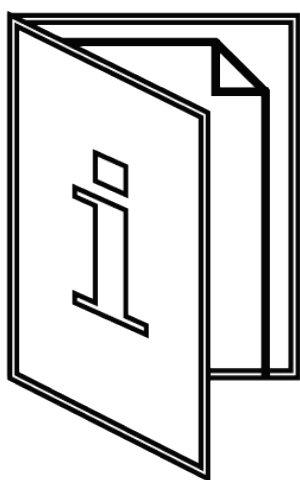
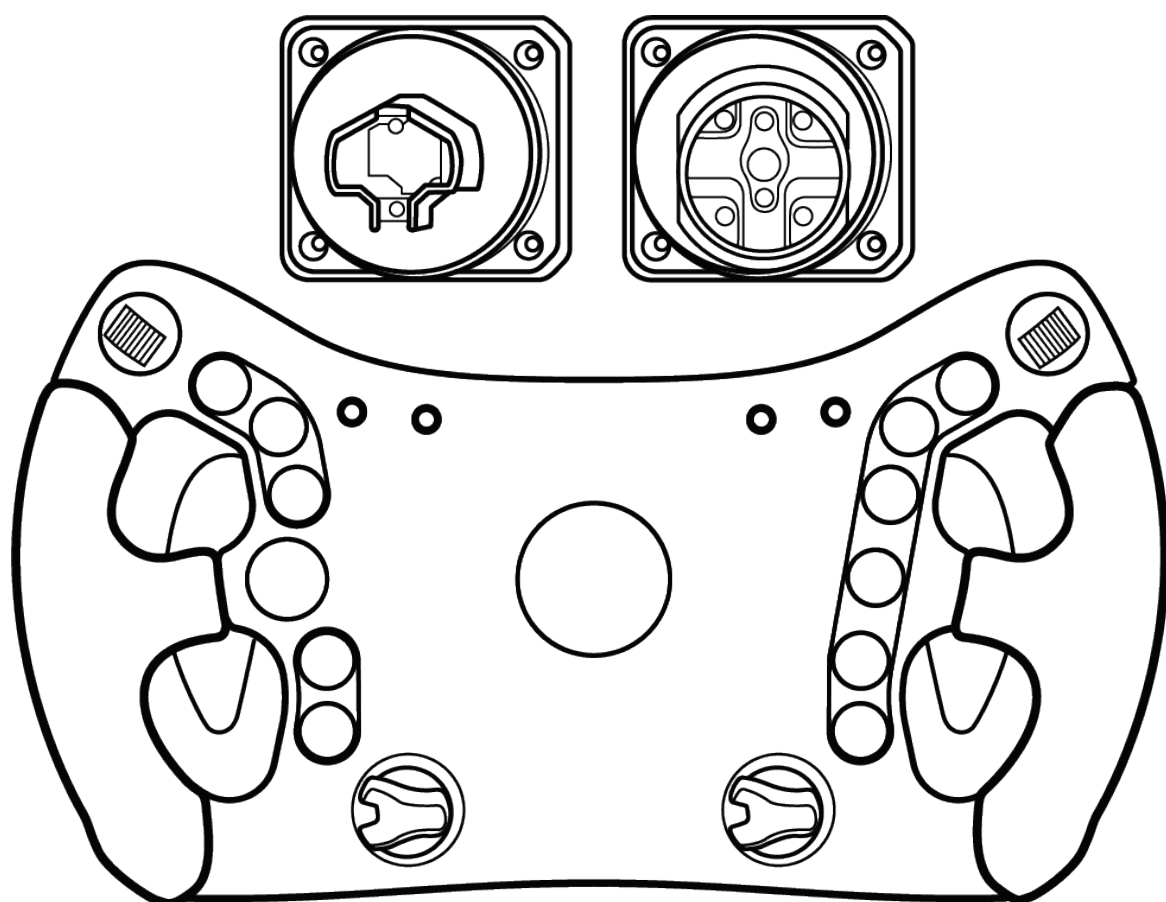



2. Funkce

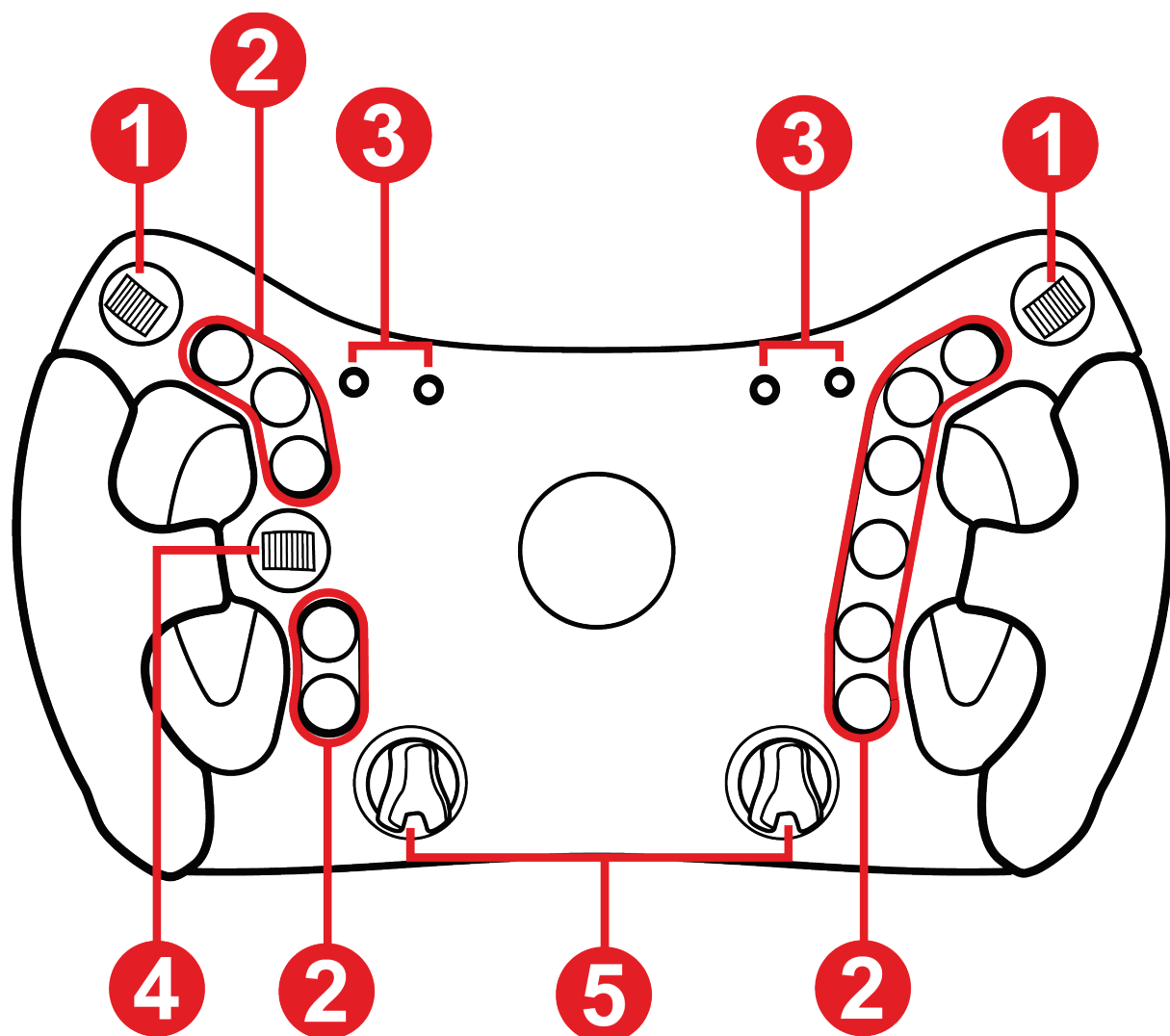

❶ Enkodéry pro palce

❷ 11 akčních tlačítek

❸ LED diody otáček a údaje ze závodu (vlajky, boxy)

❹ D-pad

❺ Rotační enkodéry

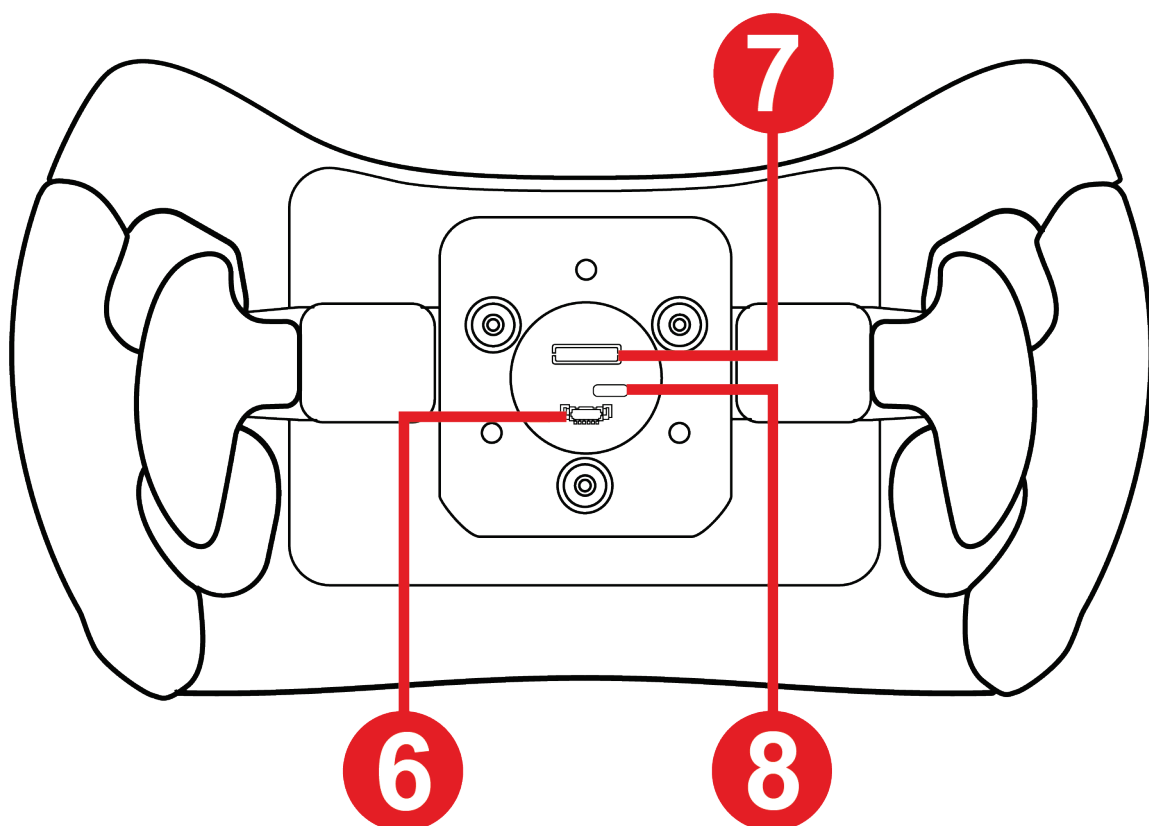

⑥ Připojovací otvor pro rychloupínací držák pro základnu se šroubem

⑦ Připojovací otvor pro rychloupínací držák základny se západkou

⑧ Port USB-C (v případě potřeby aktualizace firmwaru - kabel není součástí dodávky)

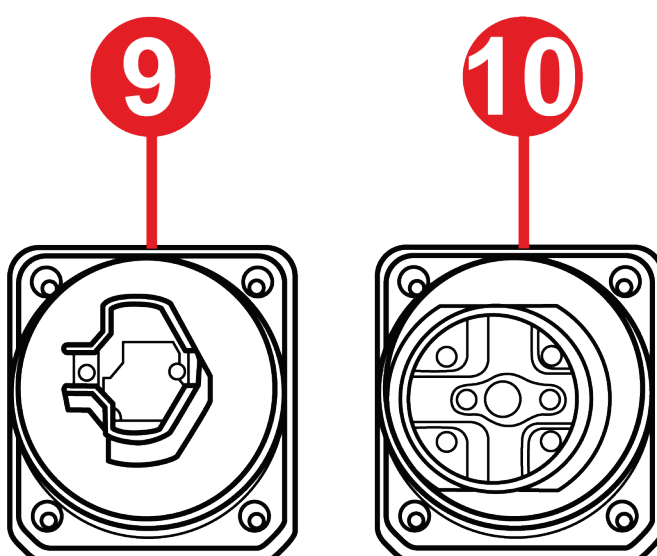

⑨ Rychloupínací držák pro základnu se západkou

⑩ Rychloupínací držák pro základnu se šroubem



3. Informace o používání volantů



Dokumentace

Před použitím tohoto výrobku si znovu pečlivě přečtěte tuto dokumentaci a uschovejte si ji pro budoucí použití.



Elektrický šok

- Výrobek uchovávejte na suchém místě a nevystavujte jej prachu ani slunečnímu záření.
- Nekruťte konektory a kabely ani za ně netahejte.
- Postupujte podle pokynů pro připojení.
- Na výrobek ani jeho konektory nelijte žádné tekutiny.
- Výrobek nezkratujte.
- Nikdy výrobek nerozebírejte (s výjimkou případů přizpůsobení uvedených v této příručce); nevhazujte jej do ohně a nevystavujte vysokým teplotám.
- Příklad neotevírejte: uvnitř se nenacházejí žádné součásti, které by mohl uživatel opravovat. Veškeré opravy musí provádět výrobce, určená agentura nebo kvalifikovaný technik.



Zabezpečení herního prostoru

- Do herního prostoru neumisťujte žádné předměty, které by mohly narušit činnost uživatele nebo které by mohly vyvolat nevhodný pohyb či vyrušení jinou osobou (například šálek kávy, telefon, klíče).
- Napájecí kabely nezakrývejte kobercem, dekou, pokrývkou ani žádným jiným předmětem a neumisťujte kabely do míst, kde se budou pohybovat lidé.



Zranění způsobená zpětnou vazbou Force Feedback a opakovanými pohyby

Používání závodního volantu se zpětnou vazbou Force Feedback může způsobit bolest svalů nebo kloubů.

Abyste se vyhnuli problémům:

- Předtím se zahřejte a vyhněte se dlouhému tréninku.
- Po každé hodině tréninku si udělejte 10 až 15minutovou přestávku.
- Pokud pocítíte únavu nebo bolest rukou, zápěstí, paží, chodidel nebo nohou, stiskněte tlačítko pro vypnutí funkce Force Feedback, vypněte základnu a několik hodin odpočívejte, než začnete znovu trénovat.
- Pokud výše uvedené příznaky nebo bolesti přetrvávají, když začnete znovu trénovat, přestaňte trénovat a poraďte se s lékařem.
- Nenastavujte zpětnou vazbu Force Feedback na úroveň, která je příliš vysoká vzhledem k vašim odborným znalostem a fyzické kondici.
- Zařízení uchovávejte mimo dosah osob mladších 16 let.
- Ujistěte se, že jsou základna a volant správně připevněny podle pokynů v příručce.



Riziko nepředvídané, silné a rychlé rotace: nikdy nevkládejte ruku nebo paži do otvorů ve věnci volantu nebo do trajektorie otáčení volantu.



Při používání výrobku nechte obě ruce vždy správně položené na volantu, aniž byste je zcela pustili.



S výrobkem mohou manipulovat pouze osoby **starší 16 let.**



4. Instalace rychloupínacího držáku

Ferrari 488 GT3 Wheel Add-On je dodáván se dvěma rychloupínacími držáky odpovídajícími formátům základny Thrustmaster.

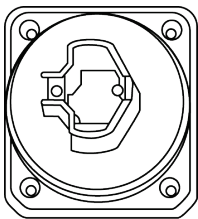
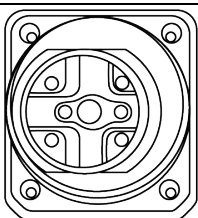
System	Kompatibilita
 Rychloupínací držák pro základnu se západkou	T818, T818 Ferrari SF1000 Simulator a budoucí základny Thrustmaster.
 Rychloupínací držák pro základnu se šroubem	T-GT / T-GT II Servo Base, T300 RS Servo Base, TS PC Racer, TS-XW, TX Racing Wheel Servo Base, TS-XW Servo Base.



Před každým použitím zkontrolujte, zda je **Ferrari 488 GT3 Wheel Add-On** stále správně připevněn k podpěře podle pokynů v příručce k základně.



Instalace rychloupínacího držáku pro základnu se západkou

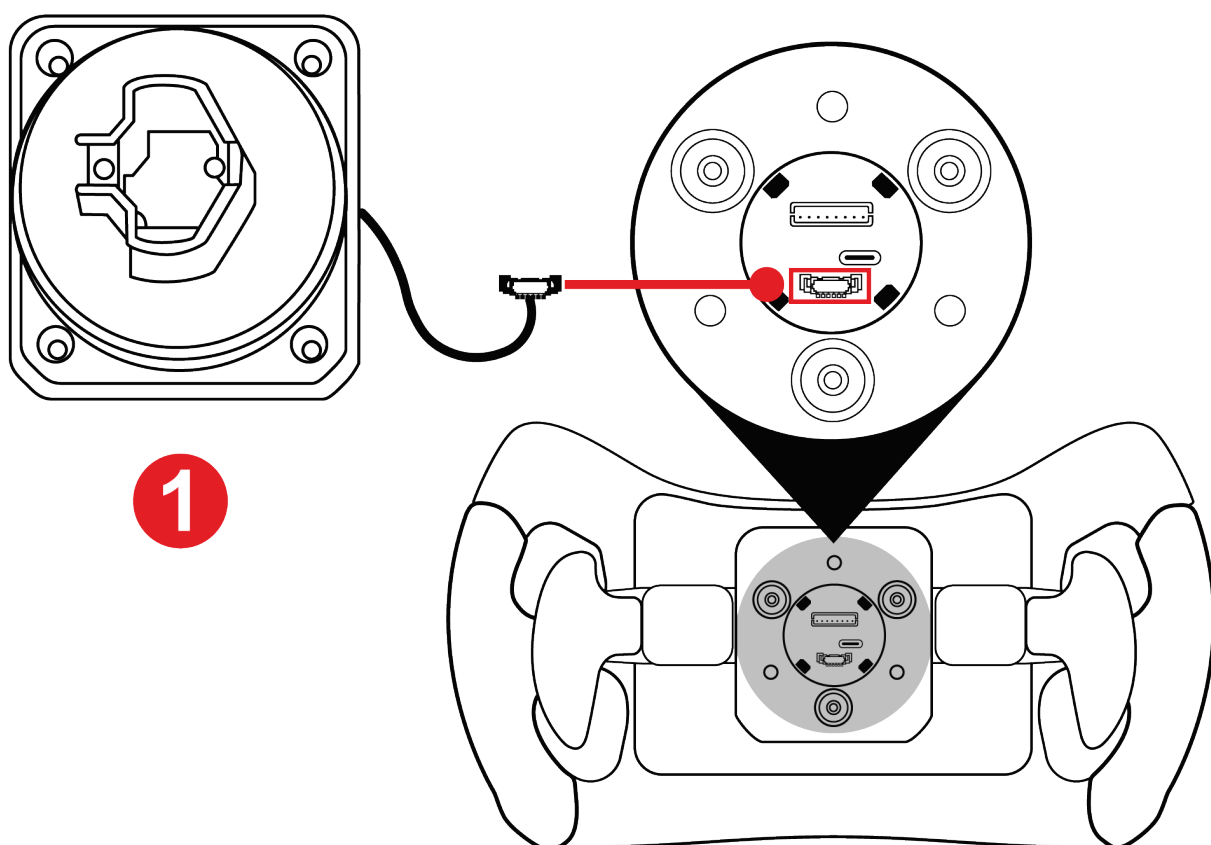

1 Zapojte konektor rychloupínacího držáku do příslušného portu na zadní straně volantu.



Aby nedošlo k přiskřípnutí kabelu, zasuňte jej před zašroubováním držáku do pouzdra.

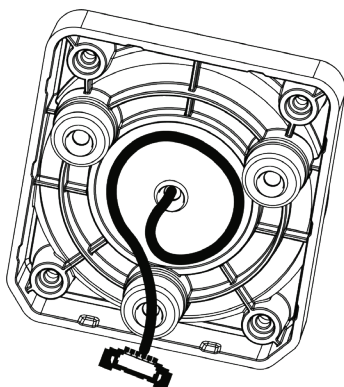

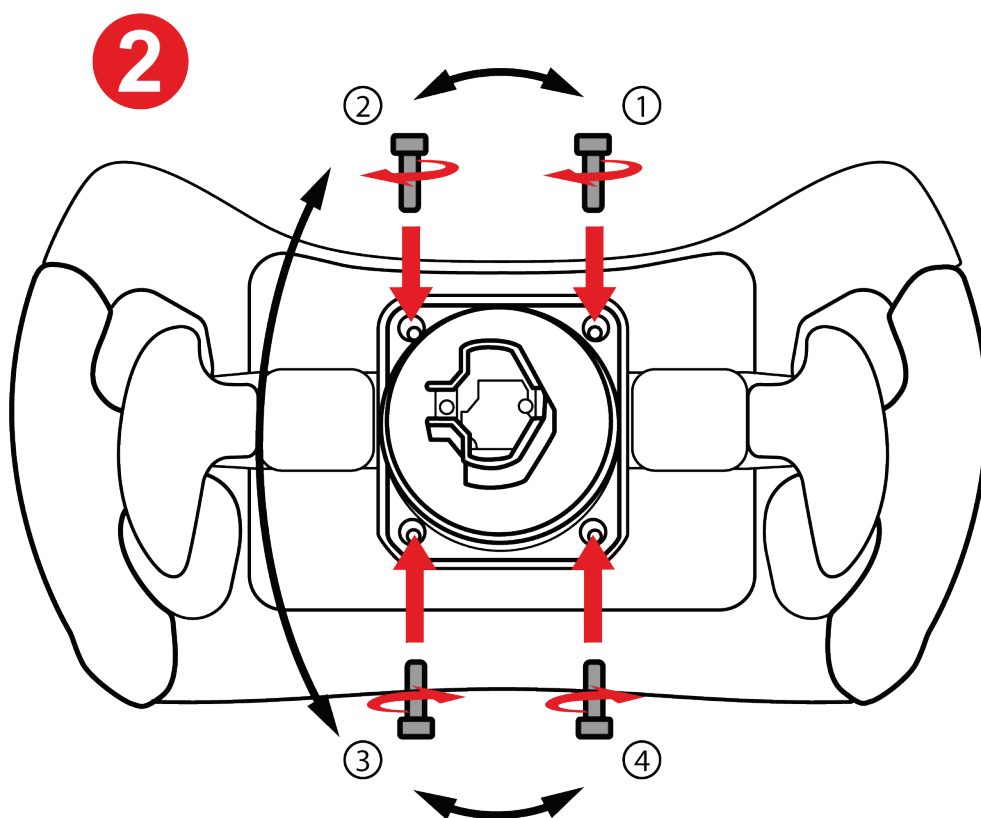

2 Vložte rychloupínací držák a utáhněte jej pomocí dodaného klíče Torx.



Při montáži držáku šrouby příliš neutahujte.

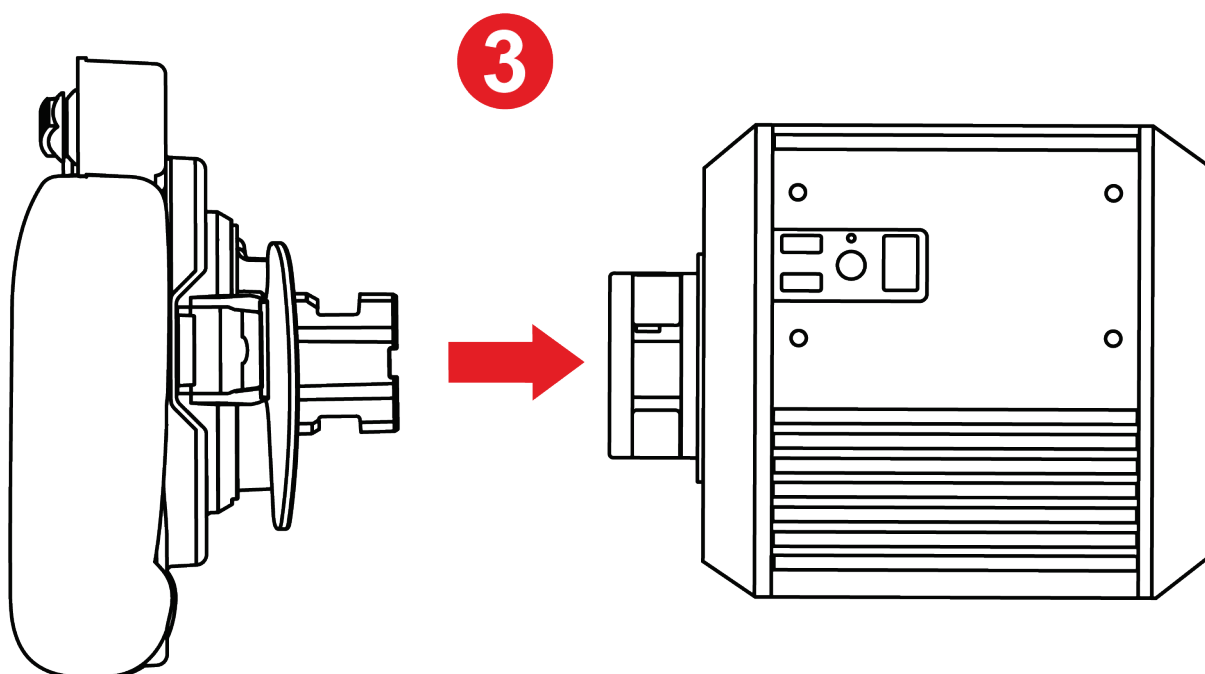

3 Namontujte volant na základnu.



Dodržujte postup instalace uvedený v uživatelské příručce základny.



Instalace rychloupínacího držáku pro základnu se šroubem

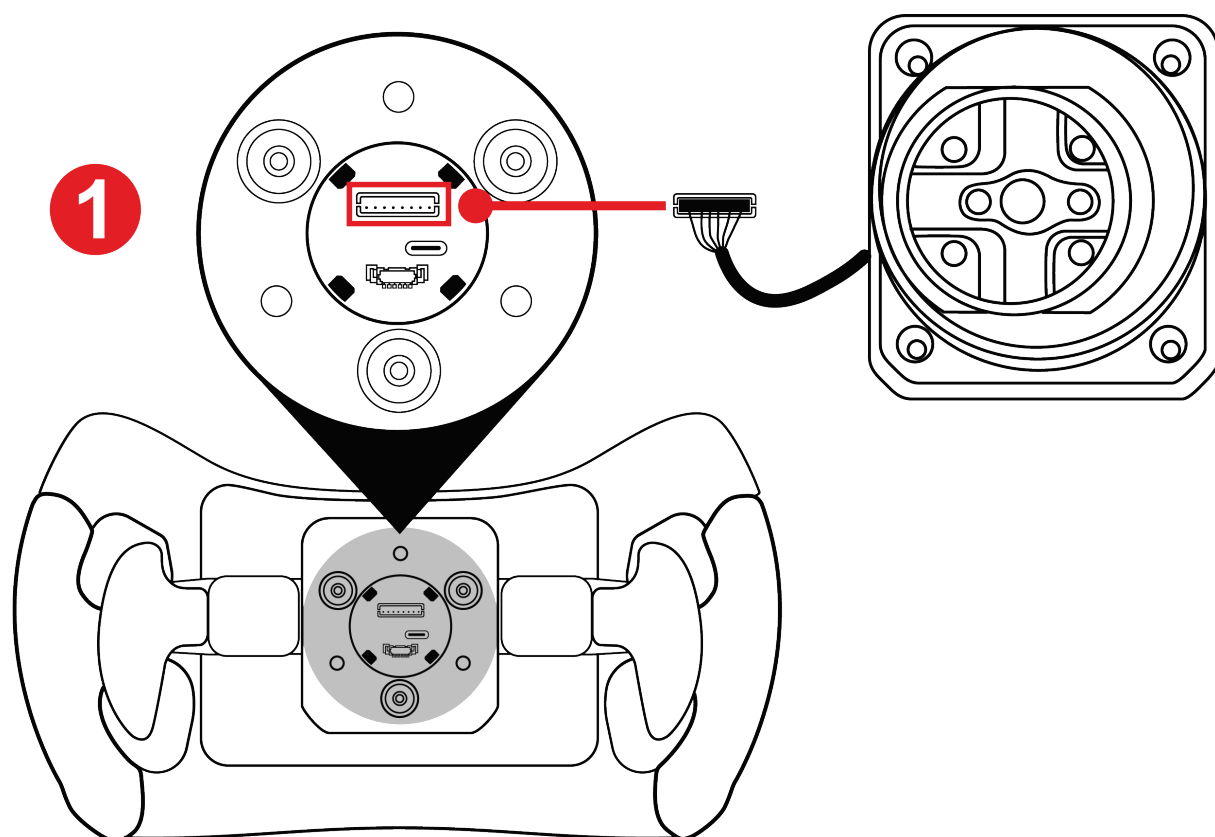

1 Zapojte konektor rychloupínacího držáku do příslušného portu na zadní straně volantu.



Aby nedošlo k přiskřípnutí kabelu, zasuňte jej před zašroubováním držáku do pouzdra.

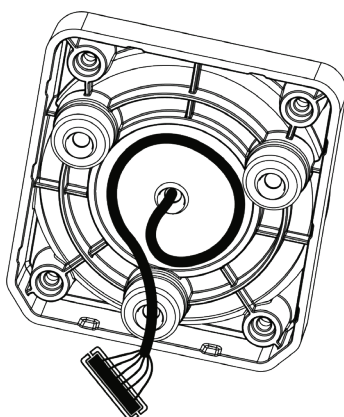

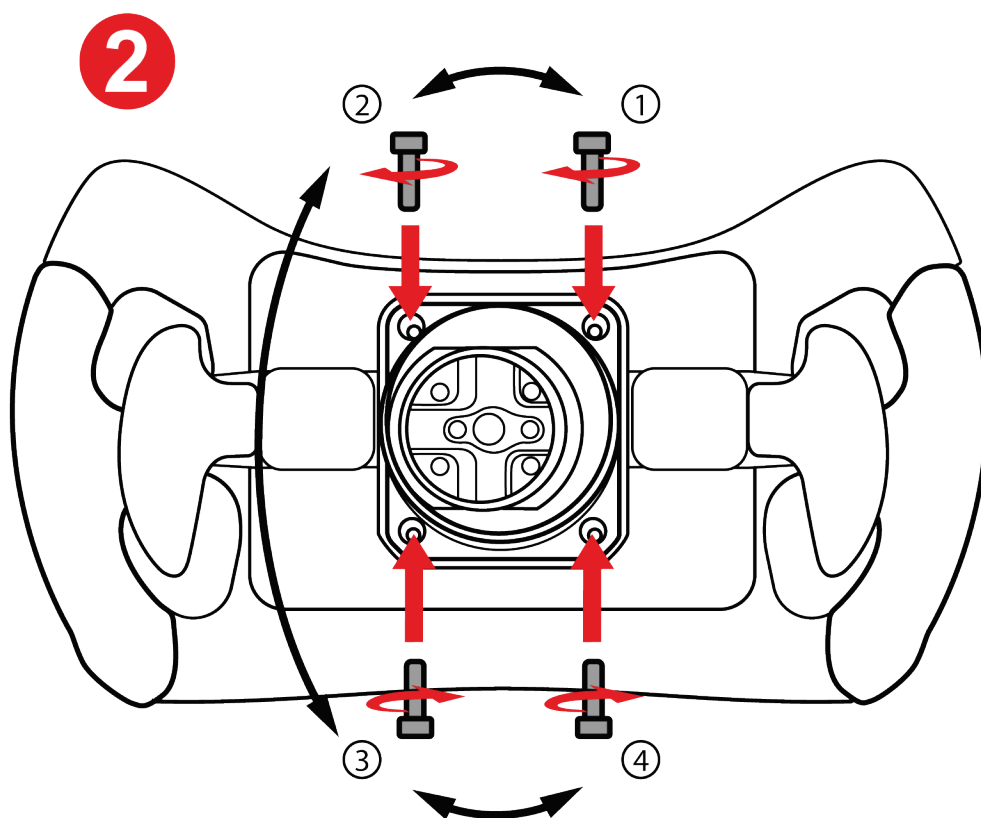

2 Vložte rychloupínací držák a utáhněte jej pomocí dodaného klíče Torx.



Při montáži držáku šrouby příliš neutahujte.

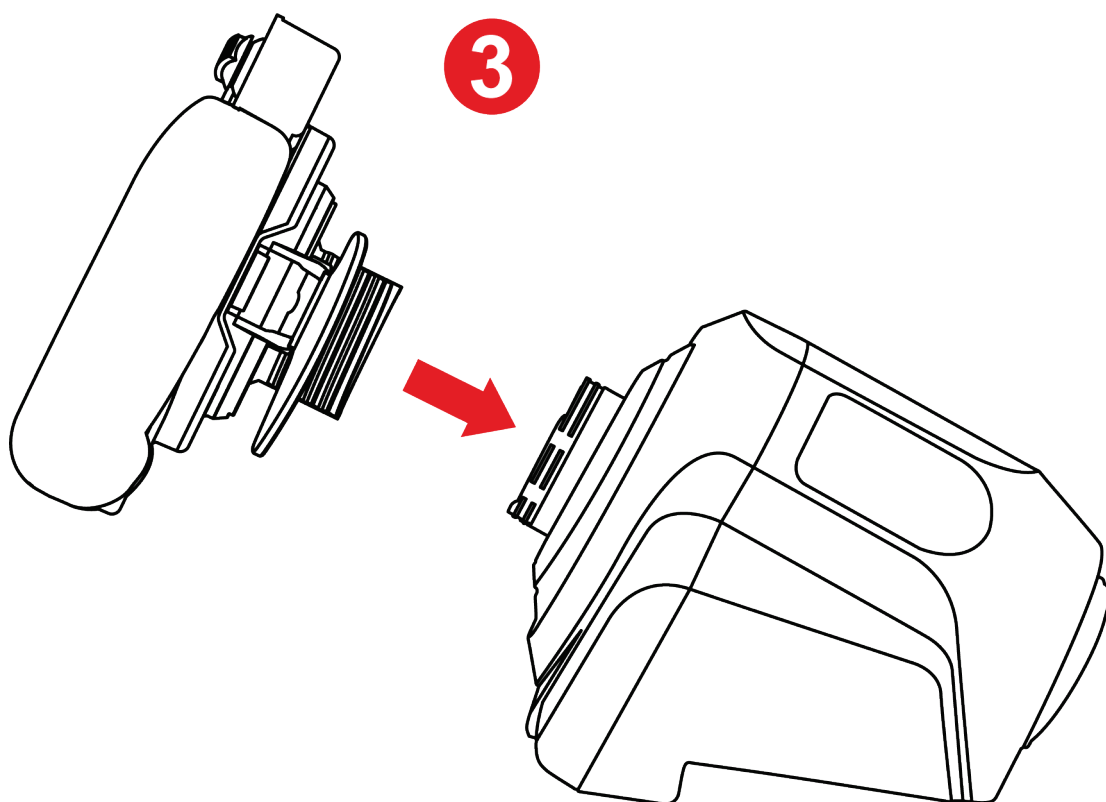

3 Namontujte volant na základnu.



Dodržujte postup instalace uvedený v uživatelské příručce základny.



Nikdy nepřipojujte Quick Release Adapter (dodávaný se základnou T818 a prodáváný samostatně) k rychloupínacímu držáku pro základnu se šroubem, pokud jej hodláte použít na základně T818.

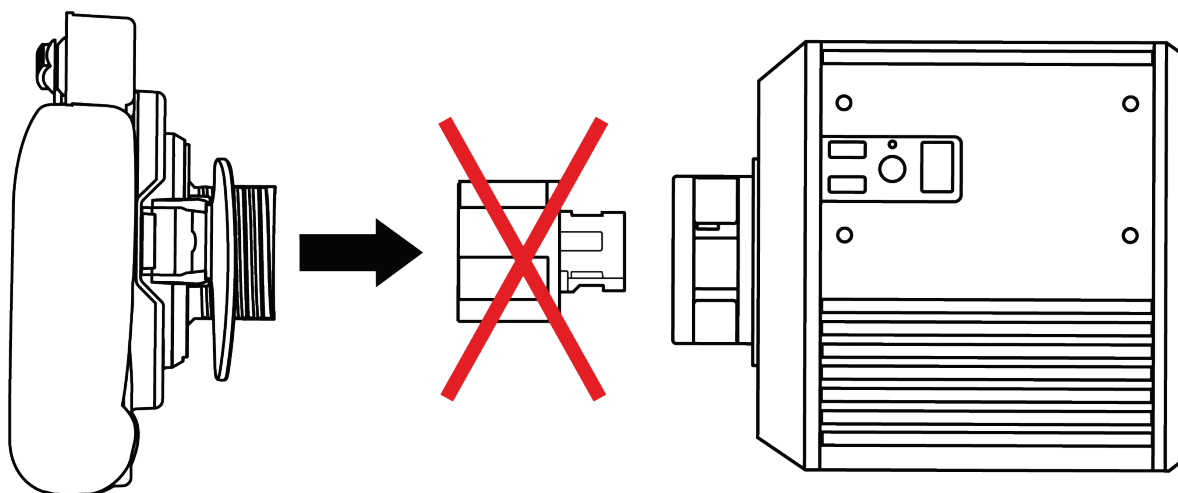
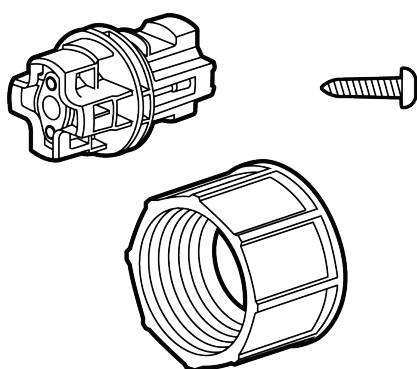

Pro použití na základně T818 nebo základně vybavené konektorem pro západkovou základnu použijte pouze **rychloupínací držák pro západkovou základnu** dodávanou s **Ferrari 488 GT3 Wheel Add-On**.



5. Mapování

Mapování pro PC

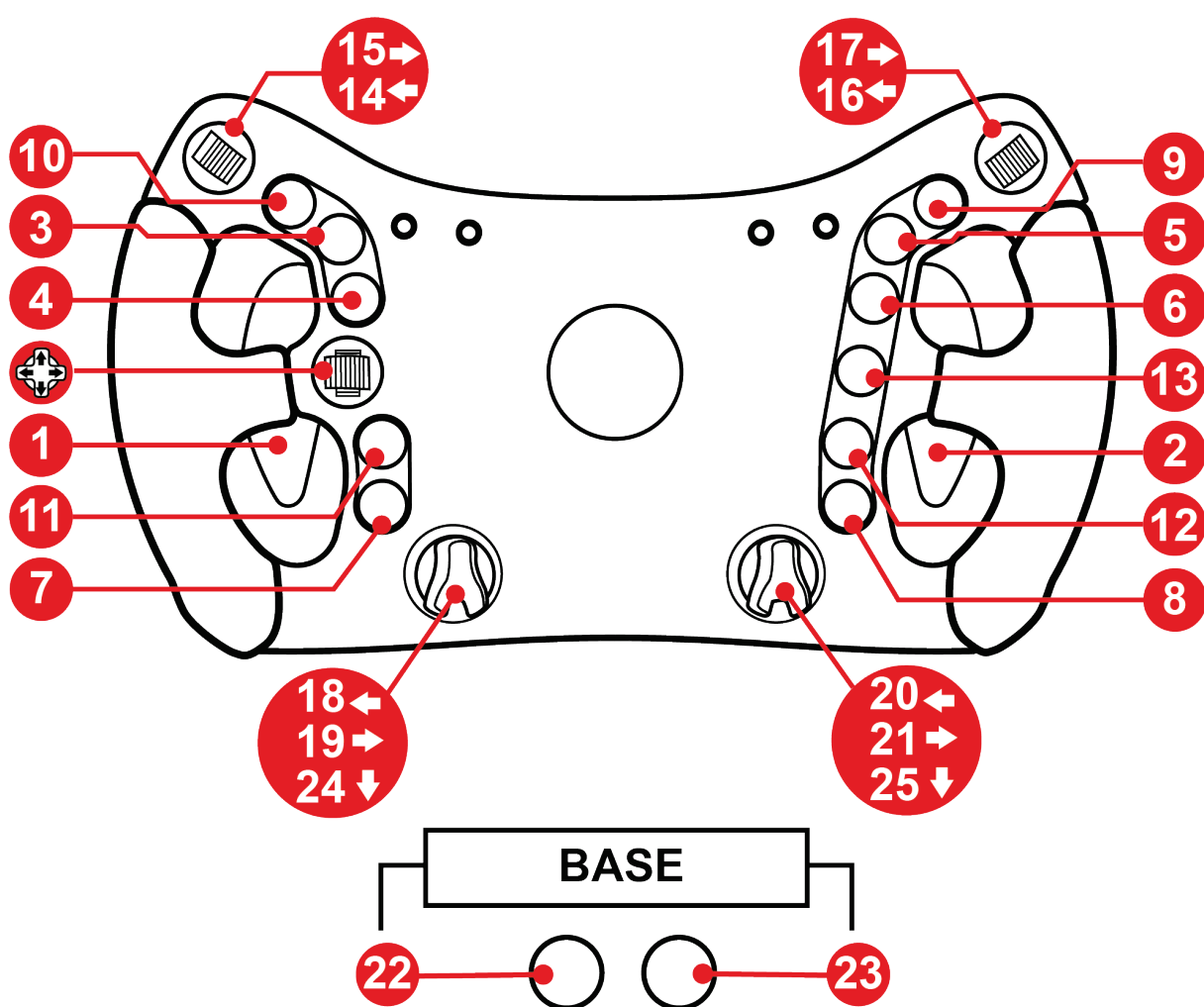



Mapování pro PS4™/PS5™

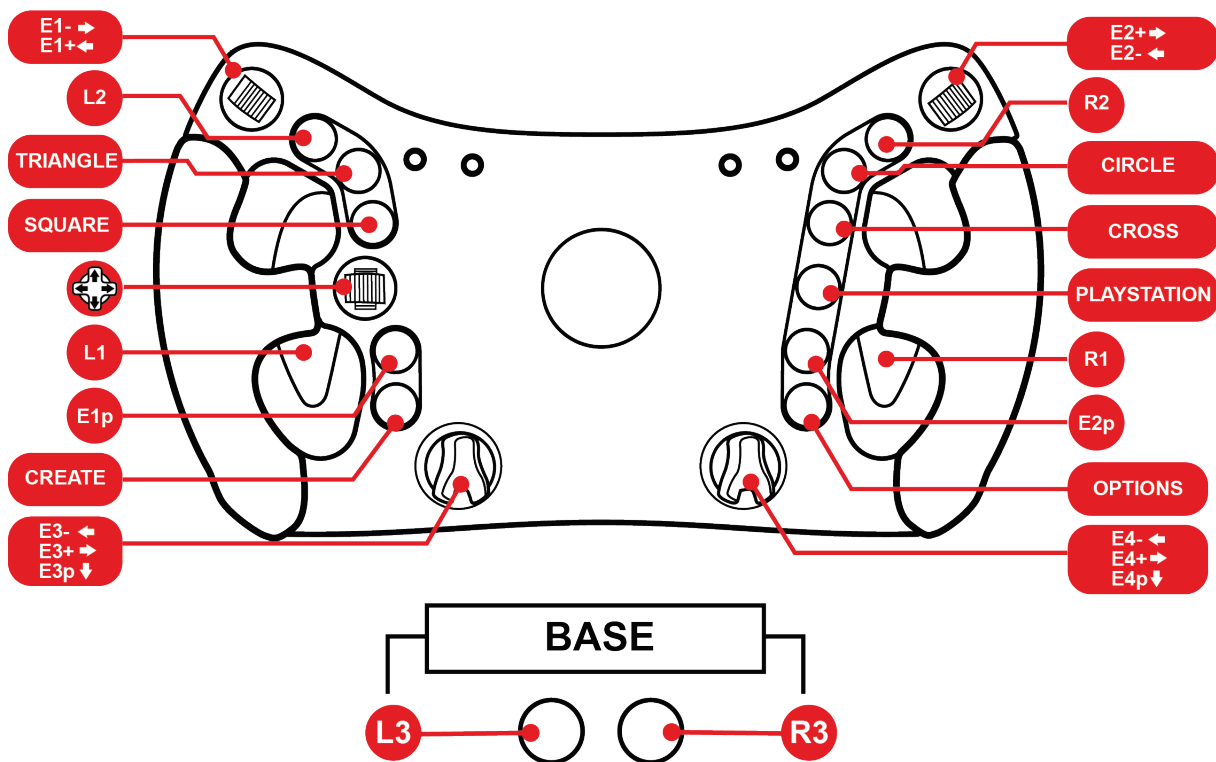



Mapování pro Xbox Series/Xbox One

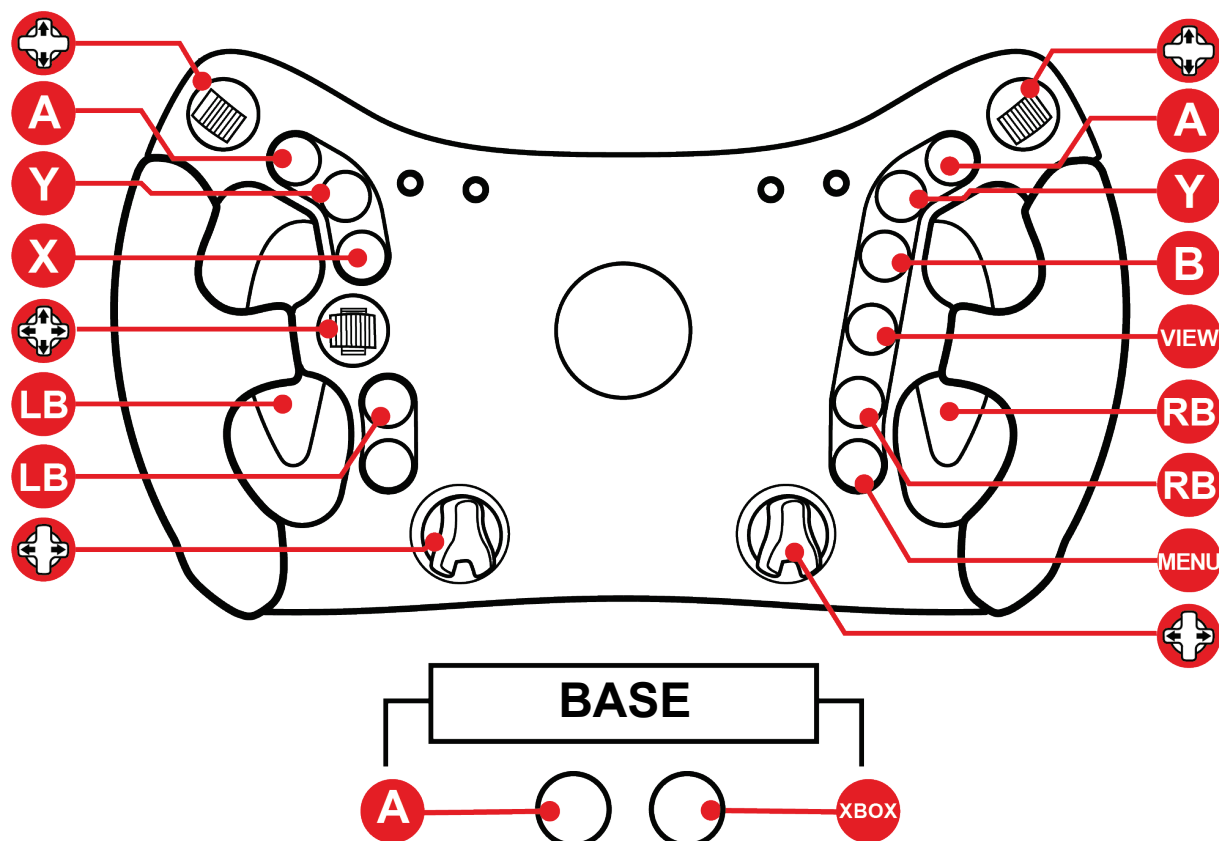

Na konzolích Xbox Series a Xbox One:

- LED diody na Ferrari 488 GT3 Wheel Add-On nejsou funkční z důvodu omezení protokolu konzole.
- Některé funkce (enkodéry, počet tlačítek) jsou omezeny protokolem konzole.



6. Provoz LED diod

Ferrari 488 GT3 Wheel Add-On zobrazuje údaje o závodě pomocí LED diod: vlajka, box a otáčky.

Zobrazované údaje lze přizpůsobit (intenzita a barva LED diod otáček) v závislosti na režimu (GT3 nebo Formula).

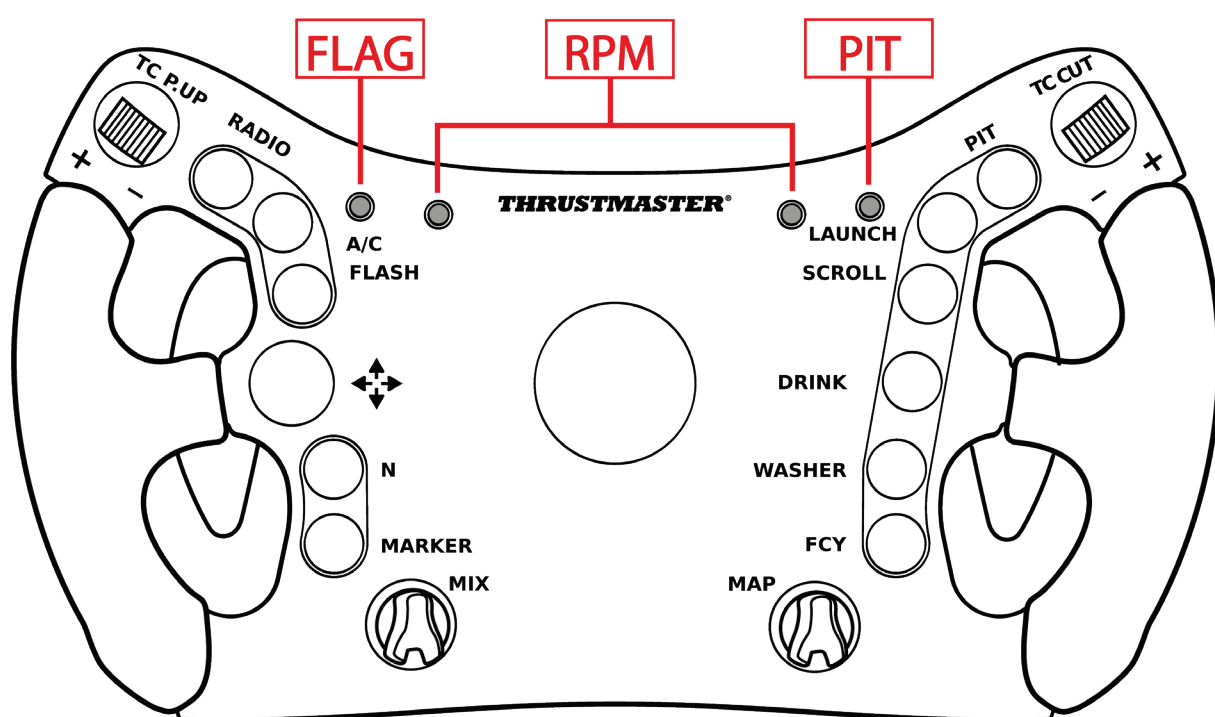

LED diody jsou funkční na PC a PS4™/PS5™.

Na konzolích Xbox Series a Xbox One nejsou diody LED funkční z důvodu omezení protokolu konzole.



Jak vstoupit do nabídky LED nebo ji opustit

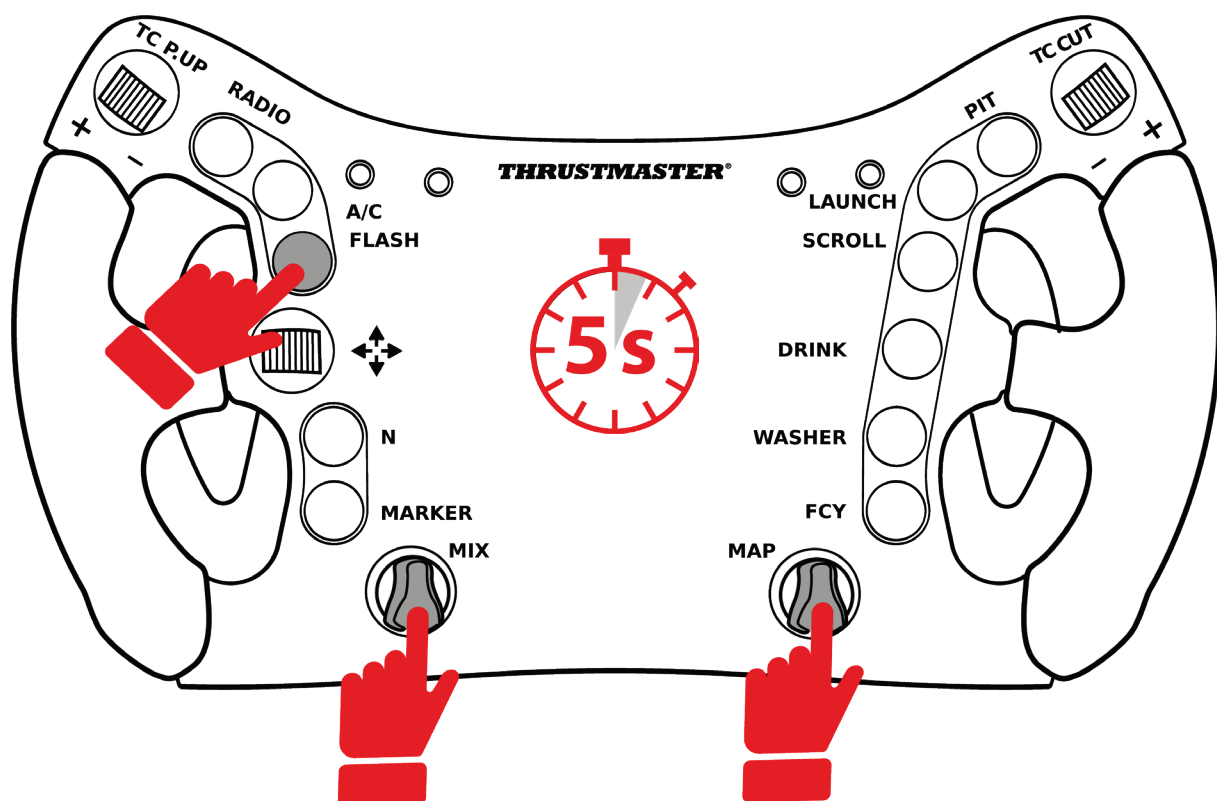

- Chcete-li vstoupit do nabídky LED, stiskněte současně tlačítko **FLASH** a oba rotační enkodéry na **5 sekund** a poté je uvolněte.
- Chcete-li opustit nabídku LED, stiskněte současně tlačítko **FLASH** a oba rotační enkodéry a poté je uvolněte.



FLAG

RPM

PIT

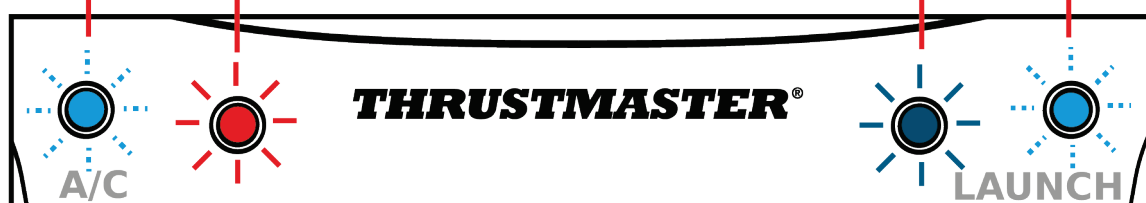

Vstup do nabídky LED: rozsvítí se LED FLAG a PIT a jedna z LED otáček (červená vlevo nebo modrá vpravo).



Výstup z nabídky LED: všechny čtyři diody LED zhasnou.



Jak nastavit intenzitu LED

- Do nabídky LED vstupte současným stisknutím tlačítka **FLASH** a obou **rotačních enkodérů** na 5 sekund a poté je uvolněte.
- Otočením **levého enkodéru (MIX)** doleva snížíte intenzitu nebo doprava zvýšíte intenzitu.



- Ukončete nabídku LED současným stisknutím tlačítka **FLASH** a obou **rotačních enkodérů** a poté je uvolněte.



Jak změnit režim LED: GT3 nebo Formula

- Do nabídky LED vstoupíte současným stisknutím tlačítka **FLASH** a obou **rotačních enkodérů** na **5 sekund** a poté je uvolněte.
- Otočením **pravého enkodéru (MAP)** doleva vyberete režim GT3 (červená LED) nebo doprava režim Formula (modrá LED).



Režim GT3 (výchozí režim)



Režim FORMULA

- Ukončete nabídku LED současným stisknutím tlačítka **FLASH** a obou **rotačních enkodérů** a poté je uvolněte.



7. Přizpůsobení řadicích pák

Řadicí páky Ferrari 488 GT3 Wheel Add-On mají nastavitelnou **rozteč** a **dosah**.

Rozteč spočívá v nastavení šířky řadicí páky, čímž se mění vzdálenost mezi rukojetí a řadicí pákou.

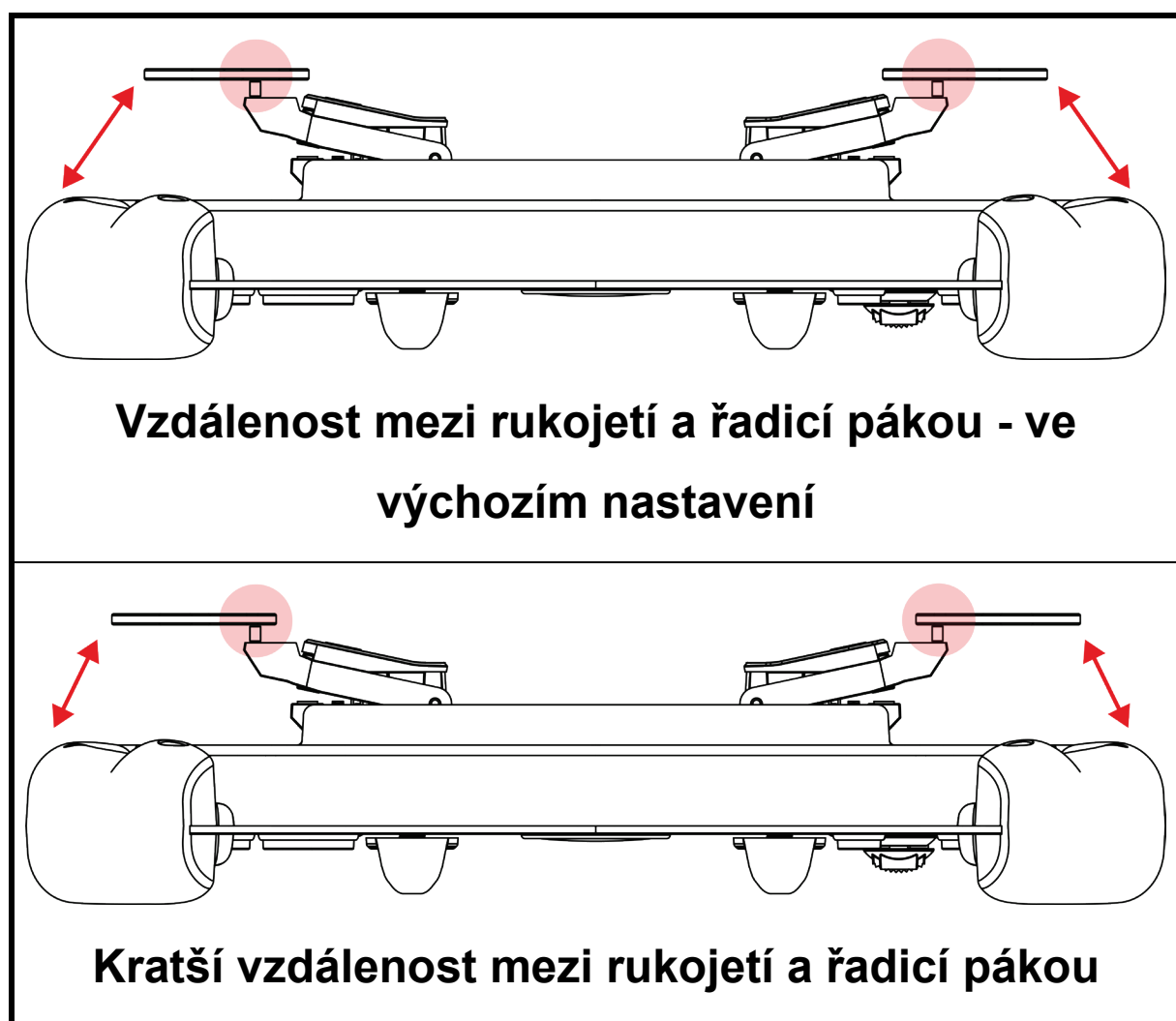



Nastavení **dosahu** pomocí rozpěrných podložek mění aktivační vzdálenost řadicí páky.

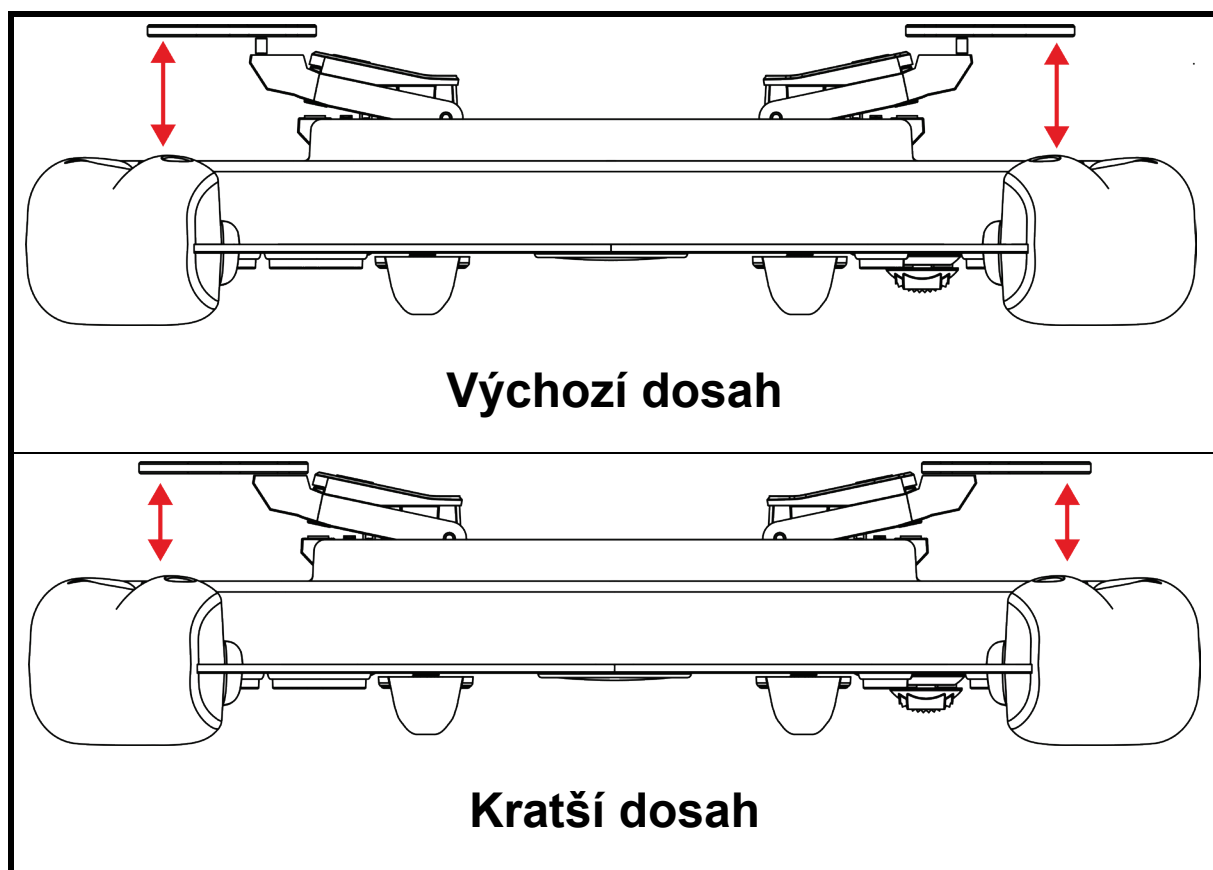

Pomocí dodávané sady podložek je také možné nastavit **magnetickou citlivost** a **úroveň zvuku** vydávaného řadicími pákami.

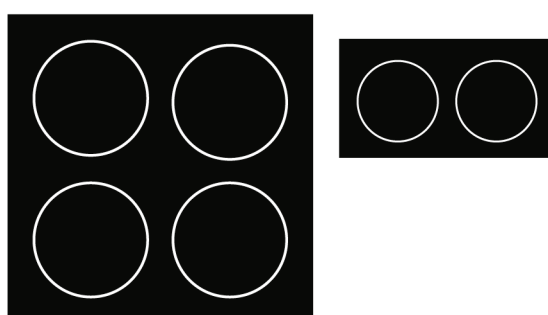



Jak nastavit rozteč řadicích pák

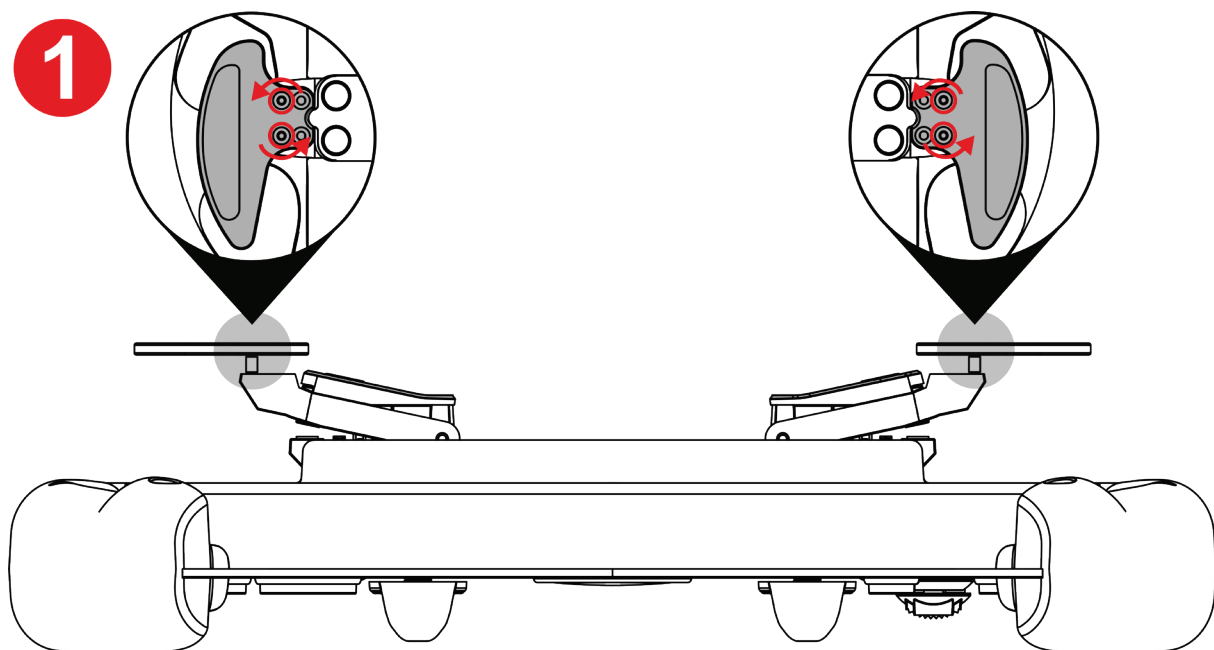

1 Odšroubujte čtyři šrouby řadicí páky pomocí dodaného klíče Torx.

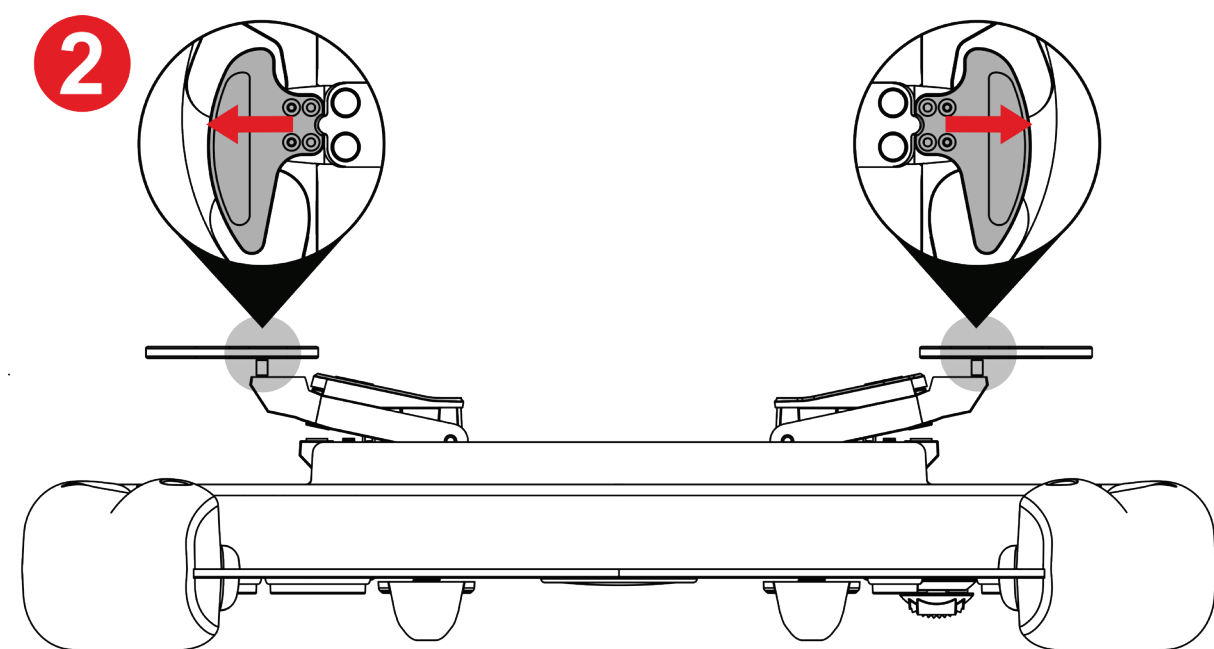

2 Posuňte řadicí páky směrem od sebe, aby lícovaly s otvory.

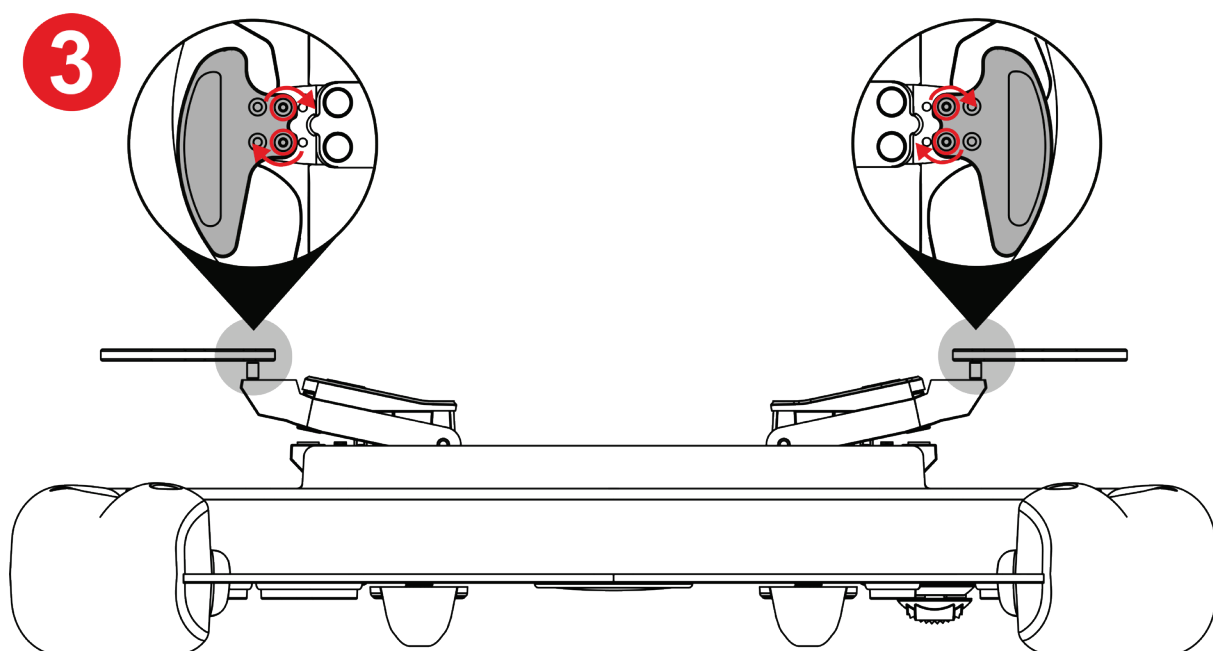

3 Utáhněte čtyři šrouby řadicí páky pomocí dodaného klíče Torx.



Jak nastavit dosah řadicí páky

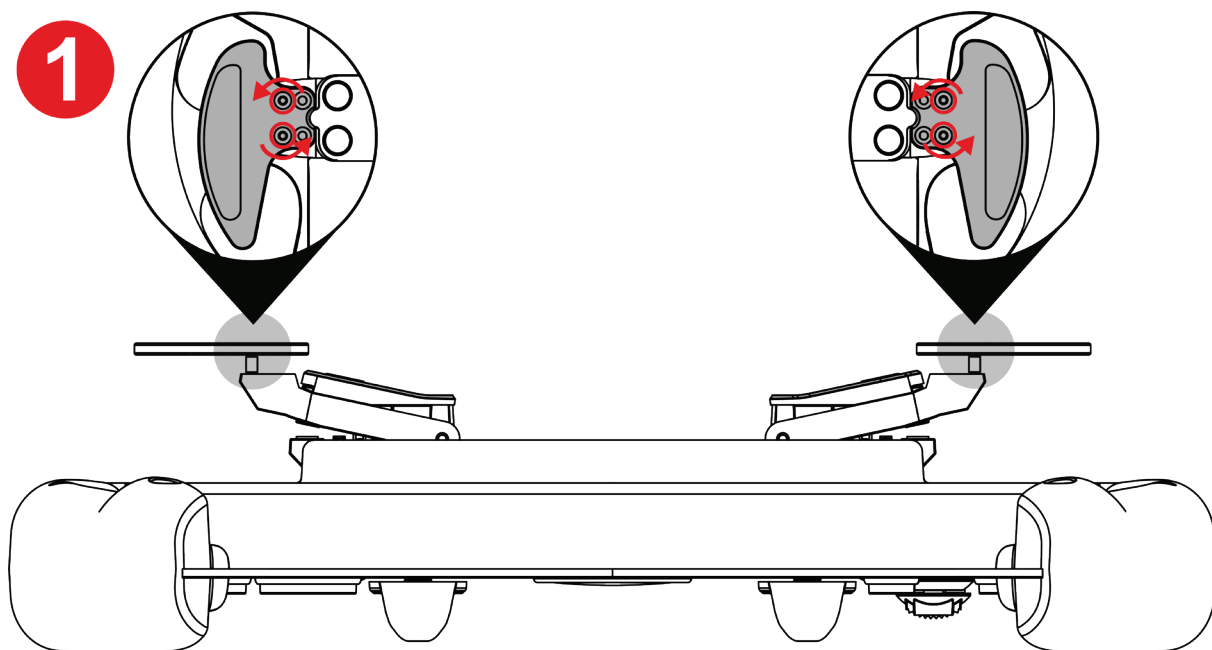

1 Pomocí dodaného klíče Torx vyšroubujte čtyři šrouby řadicí páky.

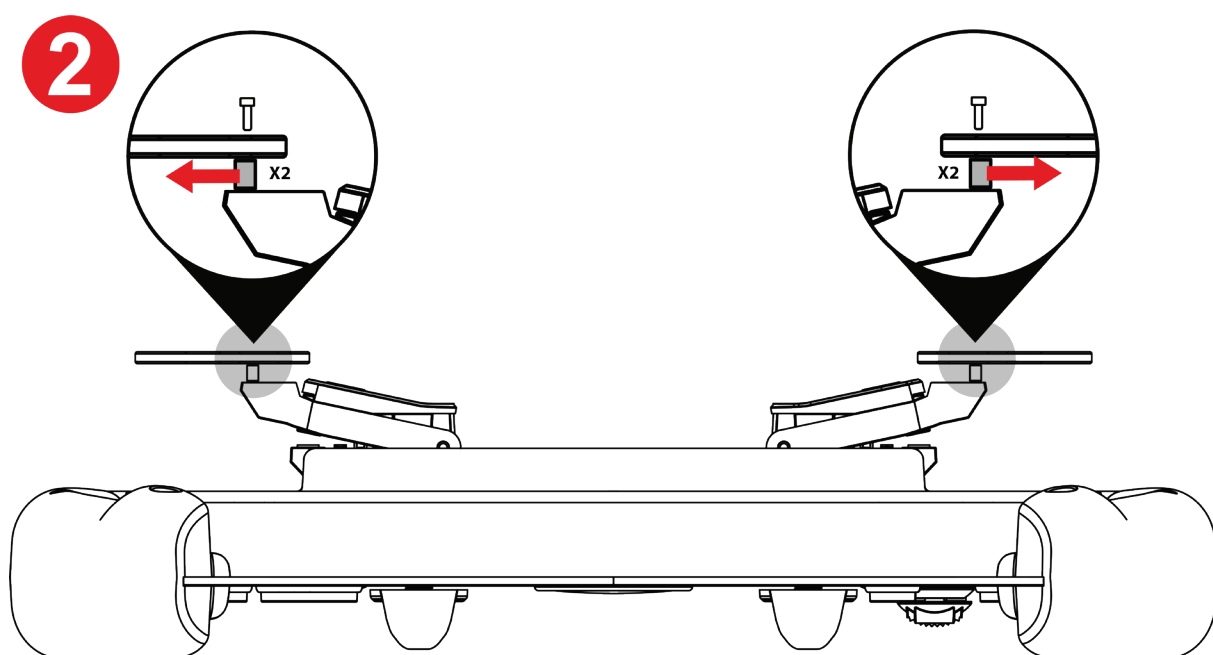

2 Odstraňte rozpěrné podložky.

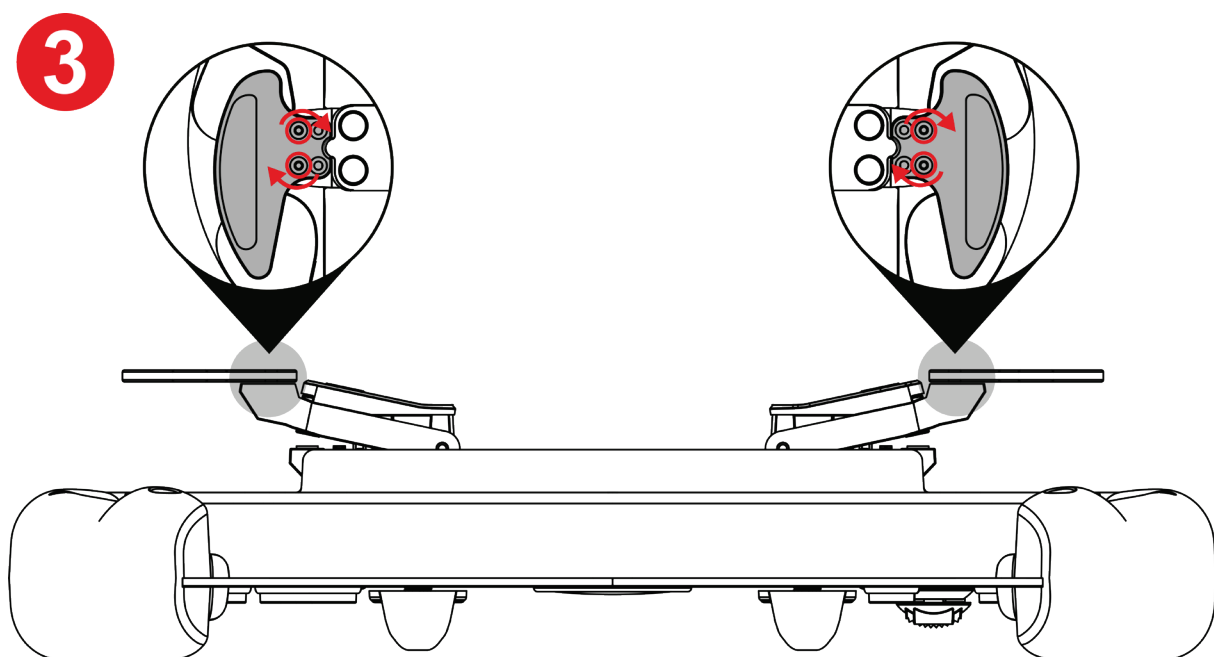

3 Utáhněte čtyři šrouby řadicí páky pomocí dodaného klíče Torx.



Jak nastavit magnetickou citlivost a úroveň zvuku řadicích pák

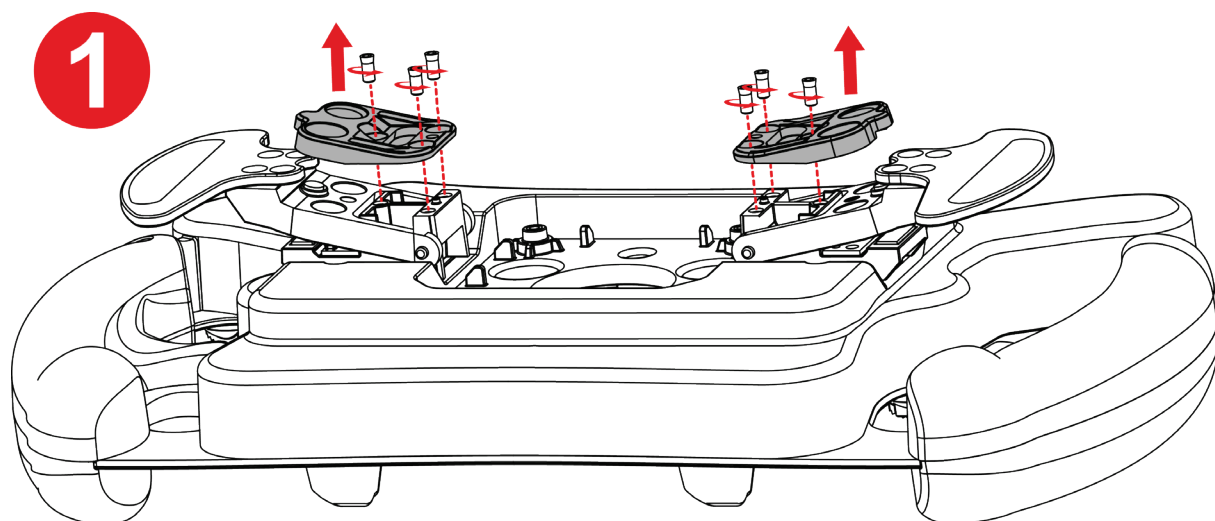

1 Odstraňte magnetické zarážky vyšroubováním šesti dorazových šroubů pomocí dodaného klíče Torx.

2

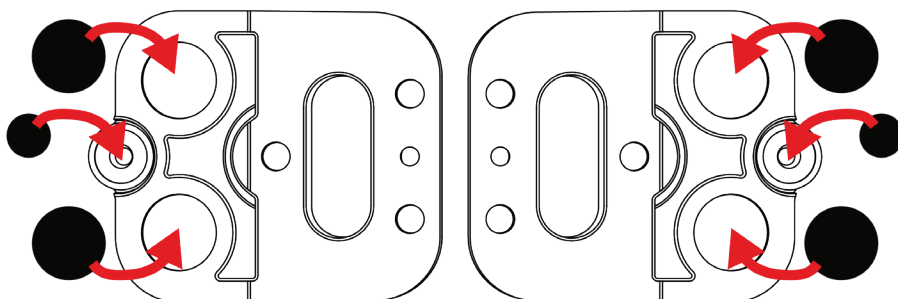
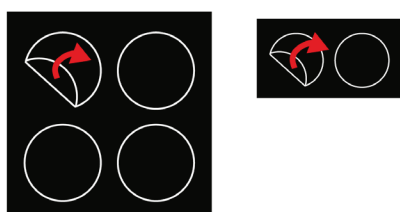

2 Odlepte dodané podložky a připevněte je na příslušná místa pod magnetické zarážky.



Možné konfigurace a jejich účinky naleznete v **tabulce Magnetická citlivost a útlum zvuku řadicích pák.**





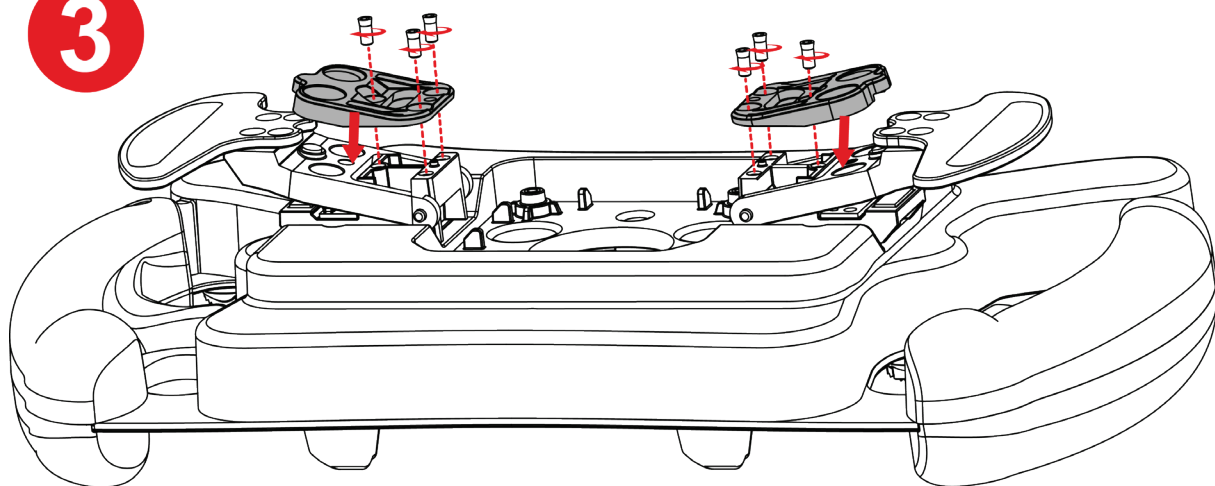

3

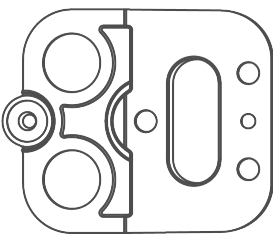
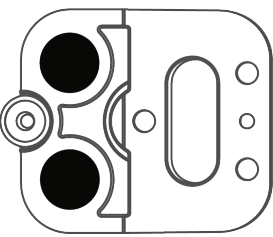
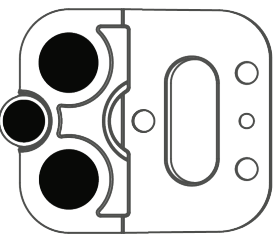

3 Znovu namontujte magnetické dorazy a utáhněte šest dorazových šroubů pomocí dodaného klíče Torx.

Tabulka Magnetická citlivost a útlum zvuku řadicích pák

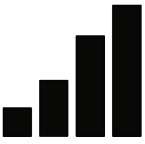
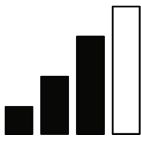
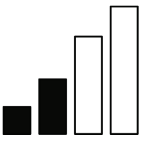
	 (výchozí)		
Magnetická citlivost			
Zvuk			



8. Často kladené dotazy a technická podpora

Máte otázky týkající se Ferrari 488 GT3 Wheel Add-On, nebo máte technické problémy? Pokud ano, navštivte webové stránky technické podpory Thrustmaster:

<https://support.thrustmaster.com/product/ferrarif488gt3addon>.

Na této stránce můžete také aktualizovat firmware volantu.



THRUSTMASTER®

FERRARI 488 GT3 WHEEL ADD-ON

PC (Windows 10/11)

PS4™ / PS5™

Xbox Series / Xbox One

Kullanıcı Kılavuzu



Ürünü monte etmeden **önce**, ürünün her türlü kullanımından **önce** ve tüm bakımlardan **önce** bu kılavuzda verilen talimatları **dikkatlice okuyun**. Güvenli talimatlarına mutlaka uyun. Bu talimatlara uyulmaması kazalara ve/veya hasara neden olabilir. Gelecekte talimatlara başvurabilmek için bu kılavuzu muhafaza edin.

İÇİNDEKİLER

1.	KUTU İÇERİĞİ	5
2.	ÖZELLİKLER.....	6
3.	DİREKSİYON KULLANIMI İLE İLGİLİ BİLGİLER	8
4.	HIZLI AYIRMALI TUTUCUNUN TAKILMASI.....	13
	<i>Mandallı taban hızlı ayırmalı tutucunun takılması</i>	<i>14</i>
	<i>Vidalı taban hızlı ayırmalı tutucunun takılması</i>	<i>17</i>
5.	EŞLEŞTİRME.....	21
	<i>PC için eşleştirme</i>	<i>21</i>
	<i>PS4™/PS5™ için eşleştirme.....</i>	<i>22</i>
	<i>Xbox Series/Xbox One için eşleştirme.....</i>	<i>23</i>
6.	LED ÇALIŞMASI	24
	<i>LED menüsüne girme/çıkma</i>	<i>25</i>
	<i>LED şiddetini ayarlama.....</i>	<i>27</i>

LED modunu deęiřtirme: GT3 veya

Formula28

7. VİTES KULAKÇIKLARINI

ÖZELLEŐTİRME29

Vites kulakçıęı ara boşluęunu ayarlama..31

Vites kulakçıęı erimini ayarlama.....33

Vites kulakçıklarının manyetik

hassasiyetini ve ses seviyesini

ayarlama35

8. SSS VE TEKNİK DESTEK37



FERRARI 488 GT3 WHEEL ADD-ON

Performans için tasarlanan ve tüm Thrustmaster direksiyon tabanlarıyla uyumlu bir direksiyon olan Ferrari 488 GT3 Wheel Add-On ile GT yarışları efsanesinin bir parçası olun.

Bu kılavuz, Ferrari 488 GT3 Wheel Add-On'u en iyi koşullarda monte edip kullanmanıza yardımcı olacaktır. Yarışmaya başlamadan önce talimatları ve uyarıları dikkatlice okuyun: Ürününüzden en üst düzeyde yararlanmanıza yardımcı olacaktır.



1. Kutu içeriđi

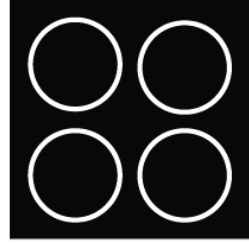
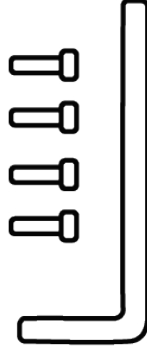
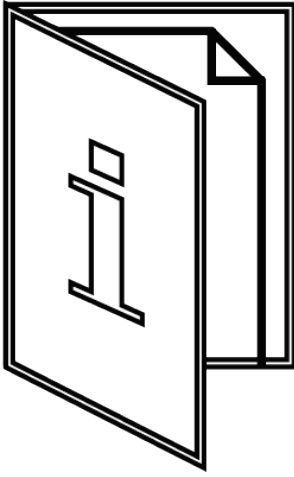
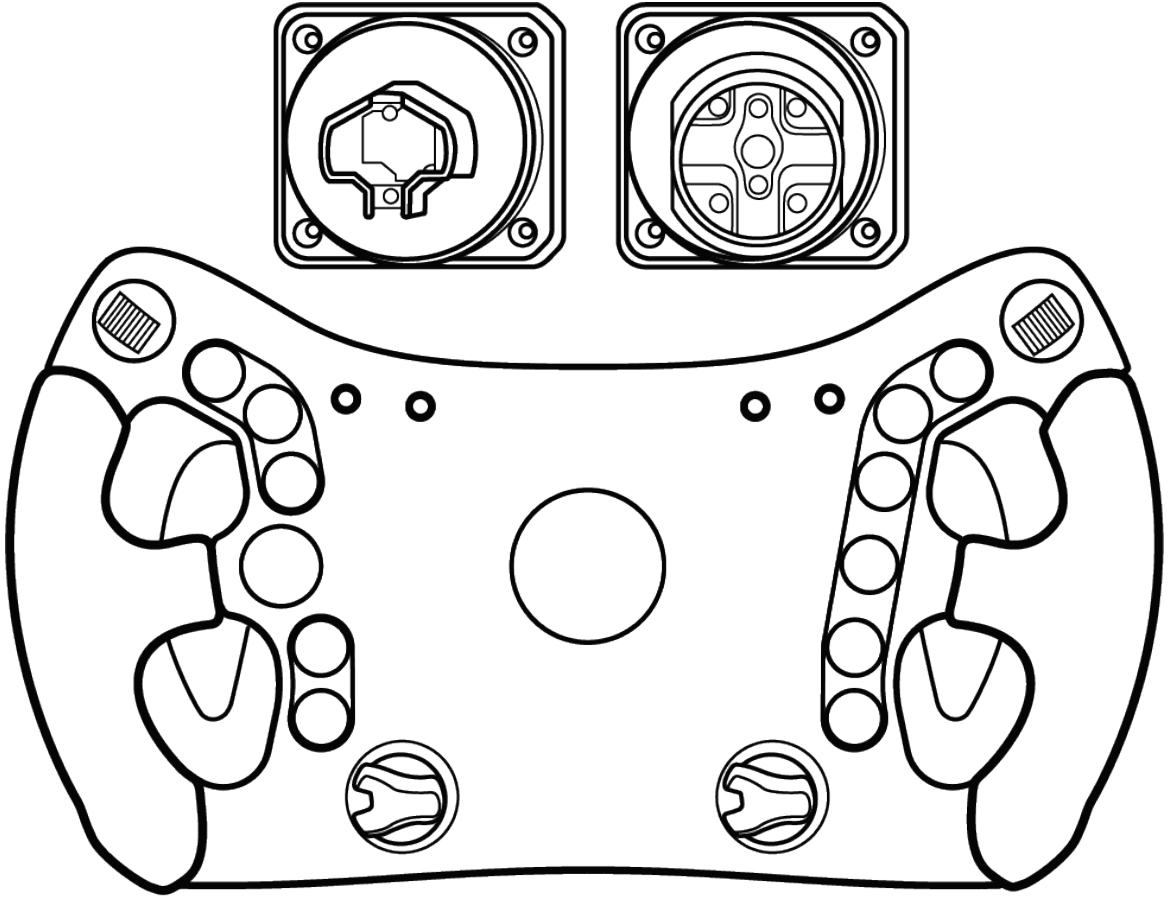



2. Özellikler

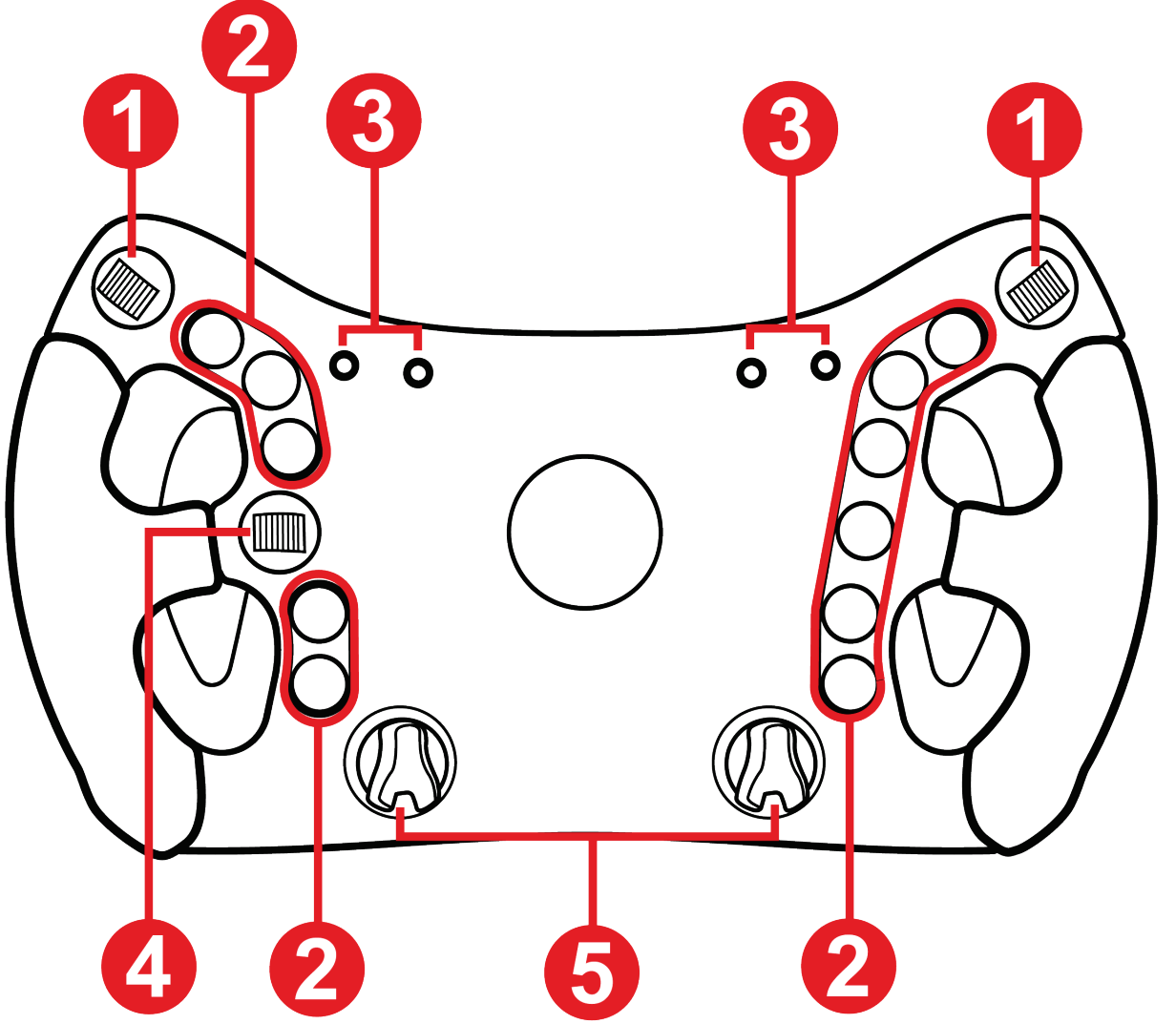

- ❶ Başparmak enkoderleri
- ❷ 11 eylem düğmesi
- ❸ Devir LED'leri ve yarış bilgileri (bayraklar, pitler)
- ❹ D-ped
- ❺ Döner enkoderler

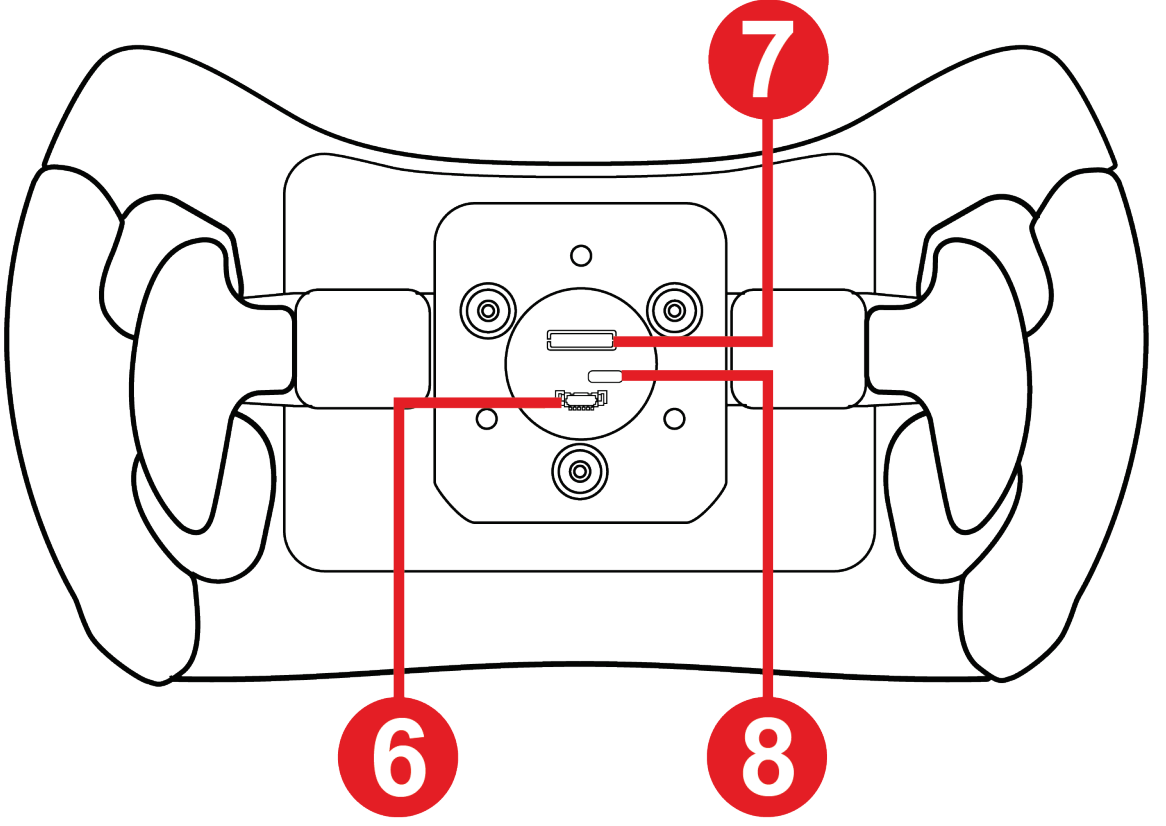

⑥ Vidalı taban hızlı ayırmalı tutucu için bağlantı noktası

⑦ Mandallı taban hızlı ayırmalı tutucu için bağlantı noktası

⑧ USB-C bağlantı noktası (donanım yazılımı güncellemesi gerekirse – kablo dahil değildir)

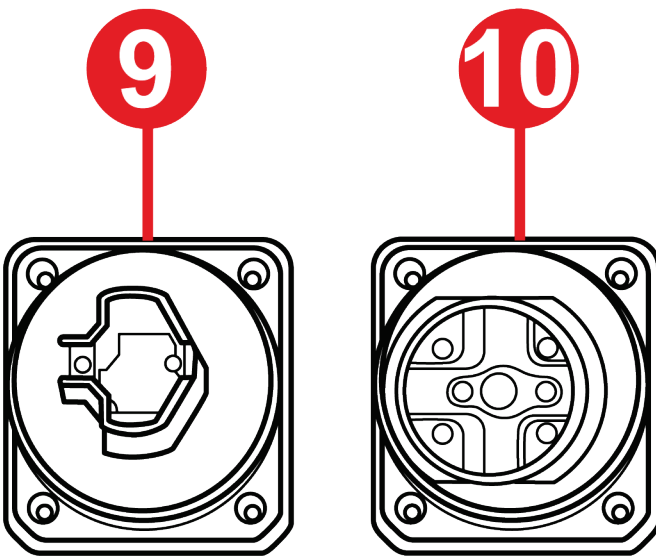

⑨ Mandallı taban hızlı ayırmalı tutucu

⑩ Vidalı taban hızlı ayırmalı tutucu



3. Direksiyon kullanımı ile ilgili bilgiler



Belgeler

Bu ürünü kullanmadan önce bu belgeyi dikkatlice yeniden okuyun ve ileride başvurmak üzere saklayın.



Elektrik arpması

- Ürünü kuru bir yerde saklayın ve toza veya güneş ışığına maruz bırakmayın.
- Konektörleri ve kabloları bükmeyin ve çekmeyin.
- Bağlantı yönlerine dikkat edin.
- Ürünün veya konektörlerinin üzerine herhangi bir sıvı dökmeyin.
- Ürünü kısa devre yapmayın.
- Ürünü asla parçalarına ayırmayın (bu kılavuzda belirtilen özelleştirme durumları hariç), ateşe atmayın ve yüksek sıcaklıklara maruz bırakmayın.
- Cihazın içini açmayın: İçinde kullanıcı tarafından bakım/onarım yapılabilecek parça yoktur. Tüm onarım işlemleri üretici firma, belirtilen temsilci veya kalifiye teknisyen tarafından yapılmalıdır.



Oyun alanının emniyete alınması

- Oyun alanına kullanıcının antrenman yapmasını aksatabilecek veya uygun olmayan bir harekete neden olabilecek ya da başka birinin oyunu bölmesine yol açabilecek hiçbir nesne (iecek kupası, telefon, anahtar, vb.) koymayın.
- Elektrik kablolarını halı veya kilim, battaniye veya rtü ya da başka bir Őeyle rtmeyin, insanların yürüdüėü yerlere kablo yerleŐtirmeyin.



Force Feedback ve tekrarlanan hareketlerden dolayı yaralanma

Force Feedback direksiyonla kullanmak kas veya eklem ağrısına neden olabilir. Her türlü sorunu önlemek için:

- Önceden ısının ve uzun süre antrenman yapmaktan kaçının.
- Her bir saatlik antrenmanın ardından 10 ila 15 dakika ara verin.
- Ellerinizde, bileklerinizde, kollarınızda, ayaklarınızda veya bacaklarınızda yorgunluk veya ağrı hissederseniz Force Feedback'i kapatma düğmesine basın, tabanı kapatın ve yeniden antrenman yapmaya başlamadan önce birkaç saat dinlenin.
- Yeniden antrenman yapmaya başladığınızda yukarıda belirtilen belirtiler veya ağrılar tekrar ederse antrenmanı durdurun ve bir doktora başvurun.
- Force Feedback'i uzmanlığınız ve fiziksel durumunuz açısından çok yüksek düzeylere ayarlamayın.
- Cihazı 16 yaşından küçük kişilerin erişemeyeceği yerlerde saklayın.
- Taban ve direksiyonun kılavuzda belirtildiği gibi düzgün bir şekilde takıldığından emin olun.



Öngörülemeyen, güçlü ve hızlı dönüşler: Direksiyon simidindeki açıklıklara veya direksiyonun dönüş yörüngesine ellerinizi veya kollarını asla koymayın.

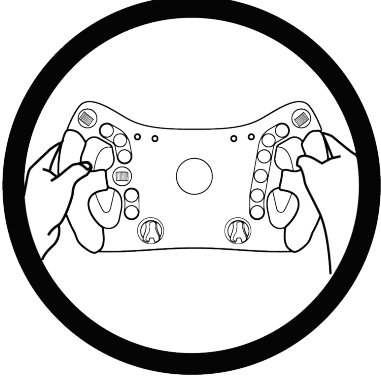

- Ürünü kullanırken her iki elinizi, asla tamamen bırakmadan, daima direksiyonun üzerinde doğru konumlandırılmış olarak bırakın.



Sadece **16 yaş ve üzeri** kişiler tarafından kullanılabilir ürün.



4. Hızlı ayırmalı tutucunun takılması

Ferrari 488 GT3 Wheel Add-On, Thrustmaster taban biçimlerine karşılık gelen iki hızlı ayırmalı tutucu ile birlikte gelir.

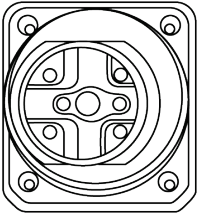
Sistem	Uyumluluk
 Mandallı taban hızlı ayırmalı tutucu	T818, T818 Ferrari SF1000 Simulator ve gelecek Thrustmaster tabanları.
 Vidalı taban hızlı ayırmalı tutucu	T-GT / T-GT II Servo Base, T300 RS Servo Base, TS PC Racer, TS-XW, TX Racing Wheel Servo Base, TS-XW Servo Base.



Her kullanımdan önce **Ferrari 488 GT3 Wheel Add-On**'un desteğe hala düzgün bir şekilde takılı olduğunu, taban kılavuzundaki talimatlara göre kontrol edin.



Mandallı taban hızlı ayırmalı tutucunun takılması

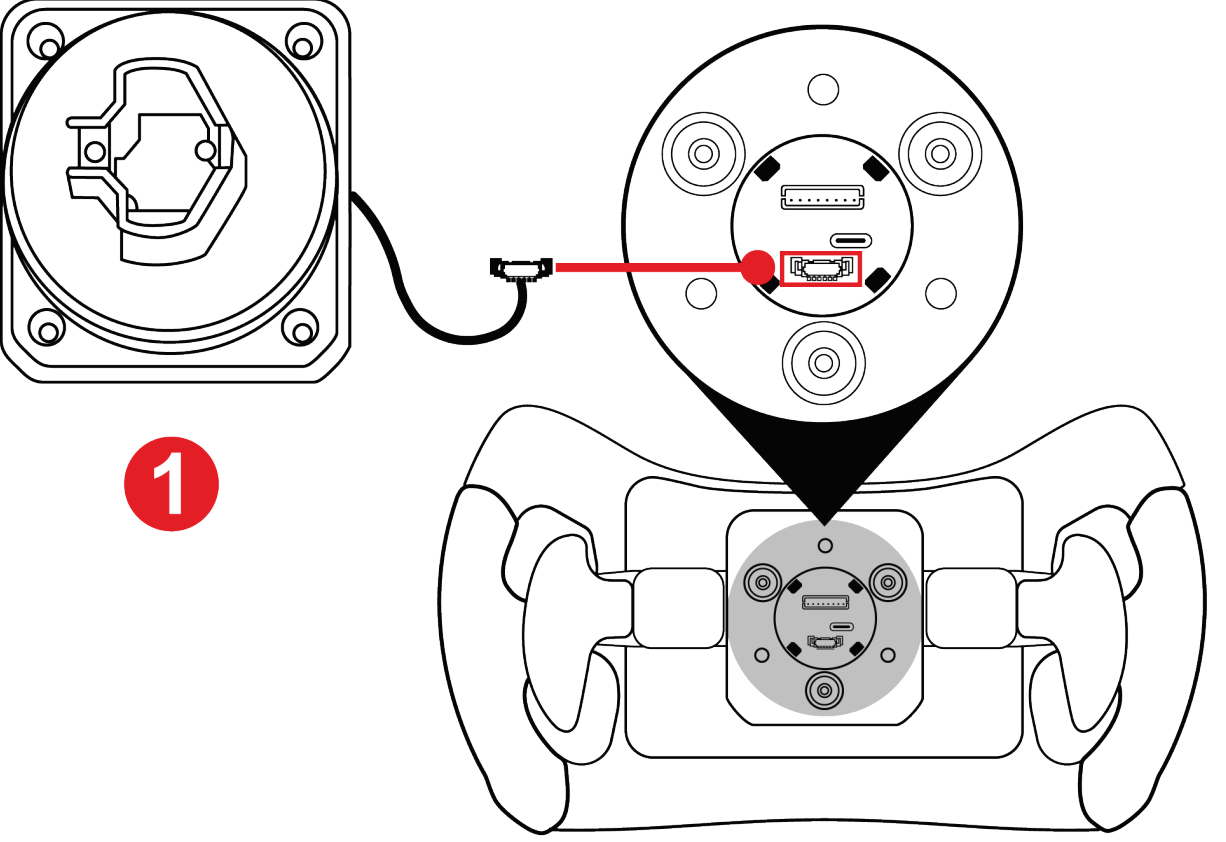

1 Hızlı ayırmalı tutucu konektörünü direksiyonunun arka kısmındaki ilgili bağlantı noktasına takın.



Kablonun sıkışmasını önlemek için tutucuyu vidalamadan önce kabloyu gövdenin içine geri çekin.

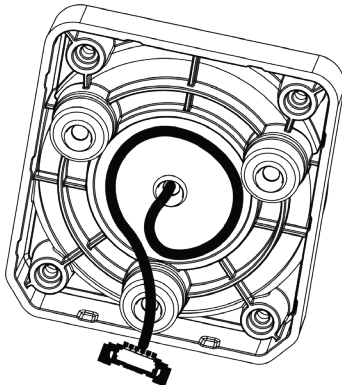

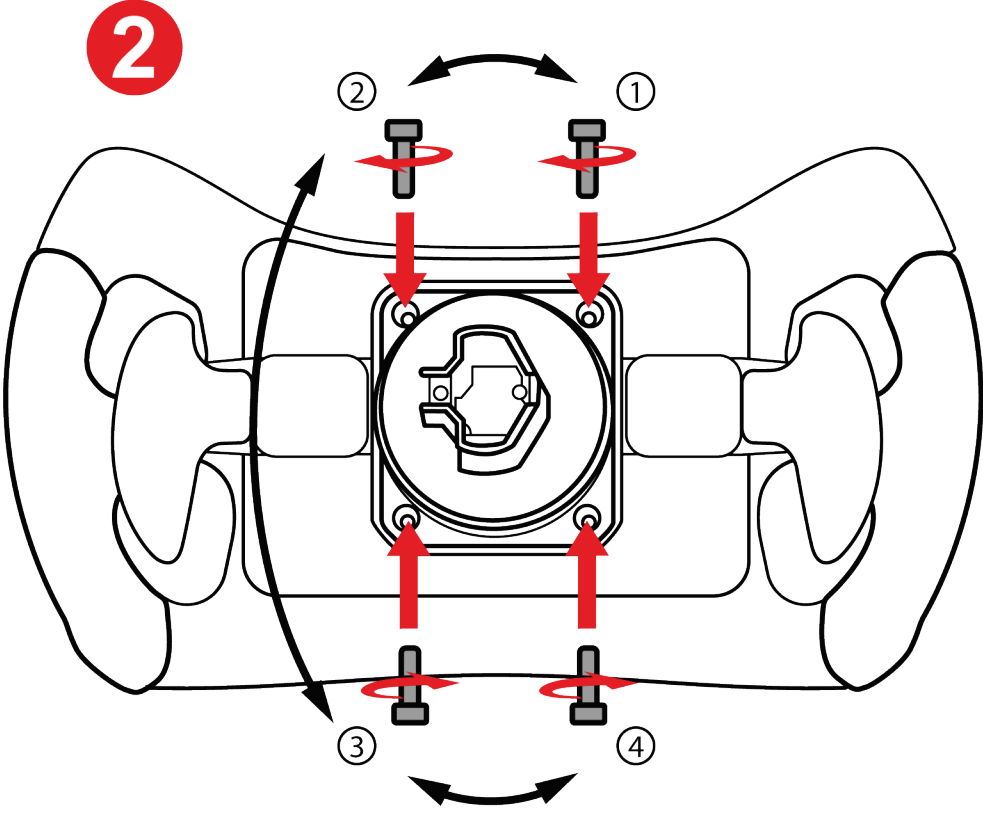

2 Hızlı ayırmalı tutucuyu takın ve verilen Torx anahtarı ile sıkın.



Tutucuyu monte ederken vidaları fazla sıkmayın.

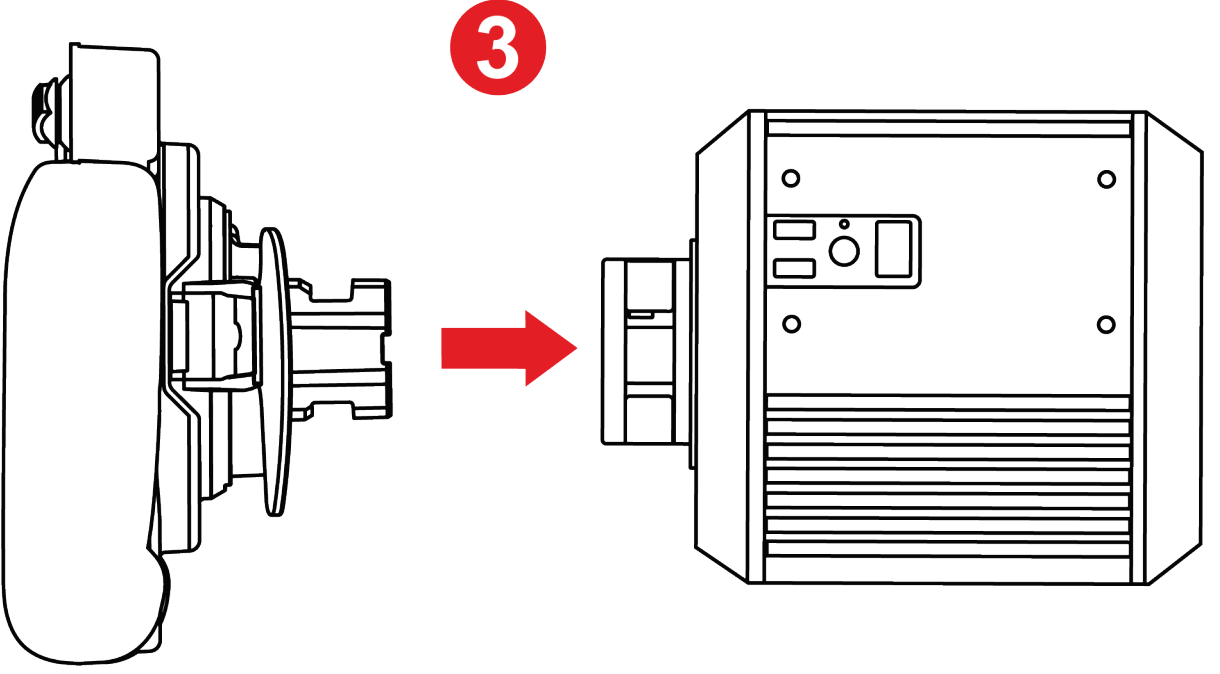

3 Direksiyonu tabana monte edin.



Tabanın kullanıcı kılavuzunda belirtilen montaj prosedürünü izleyin.



Vidalı taban hızlı ayırmalı tutucunun takılması

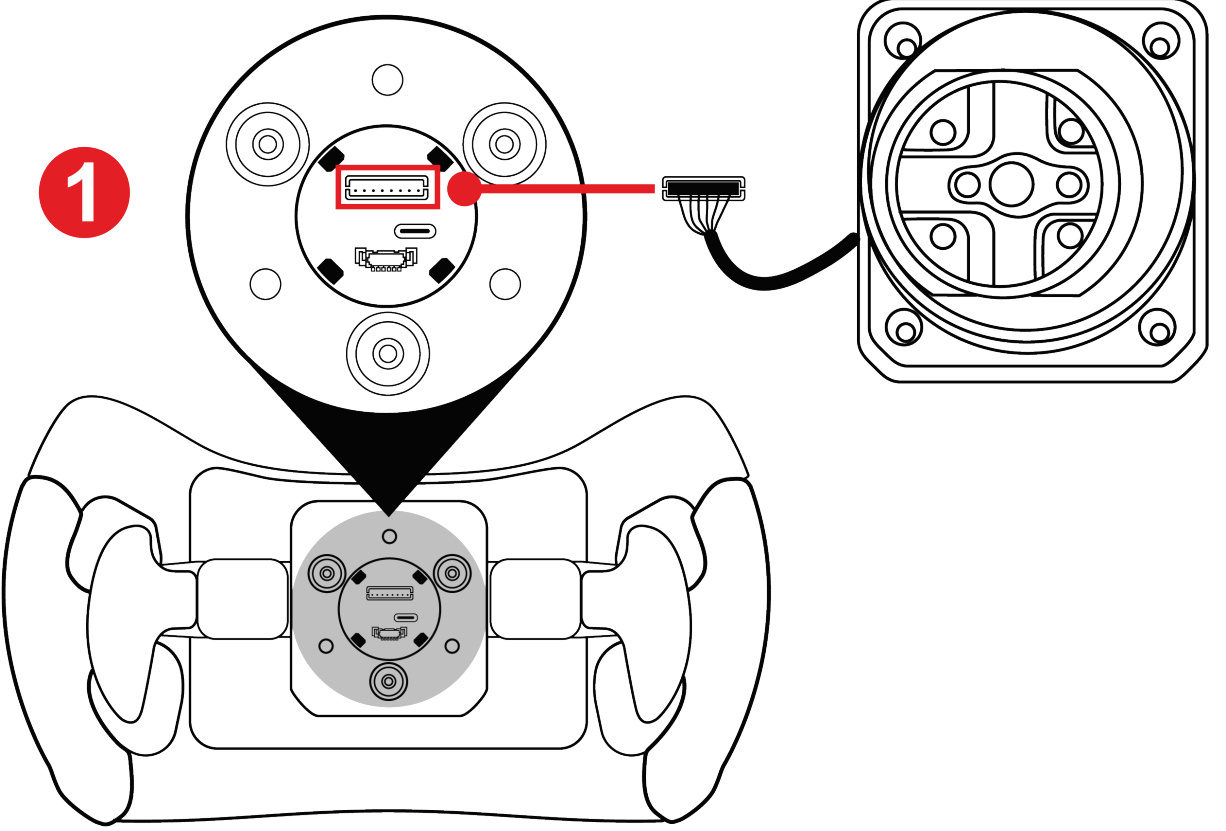

1 Hızlı ayırmalı tutucu konektörünü direksiyonunun arka kısmındaki ilgili bağlantı noktasına takın.



Kablonun sıkışmasını önlemek için tutucuyu vidalamadan önce kabloyu gövdenin içine geri çekin.

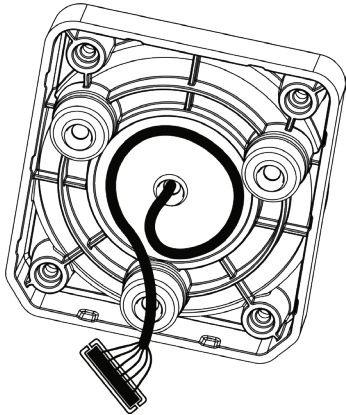

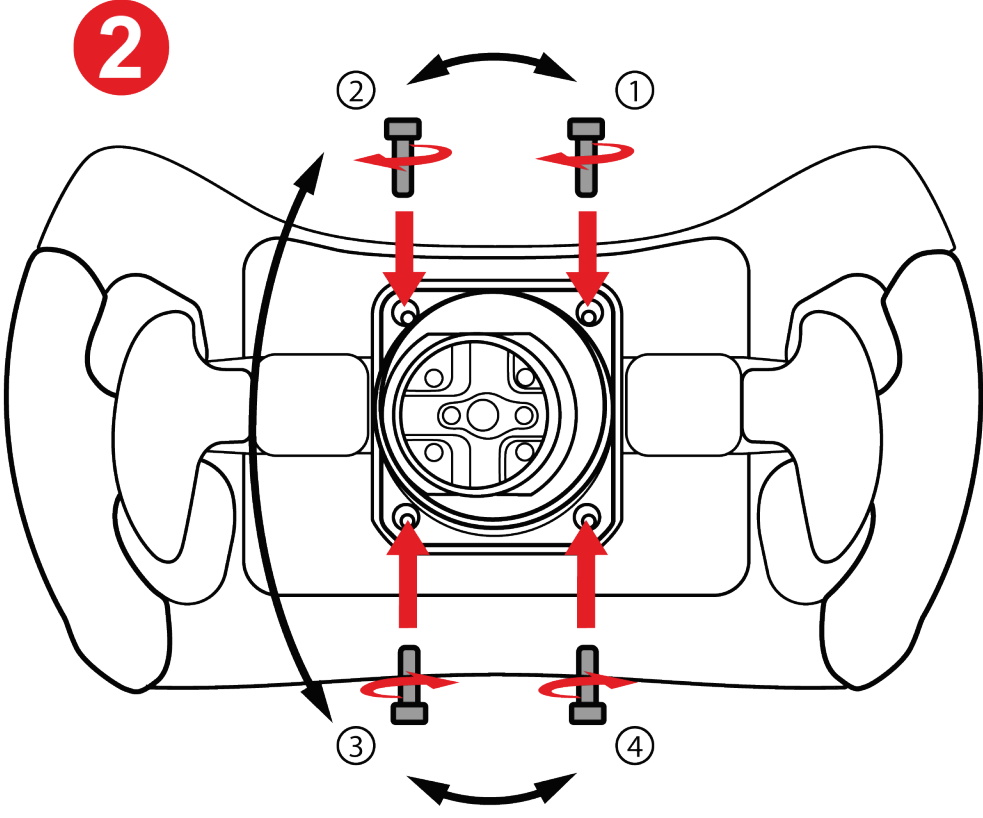

2 Hızlı ayırmalı tutucuyu takın ve verilen Torx anahtarı ile sıkın.



Tutucuyu monte ederken vidaları fazla sıkmayın.

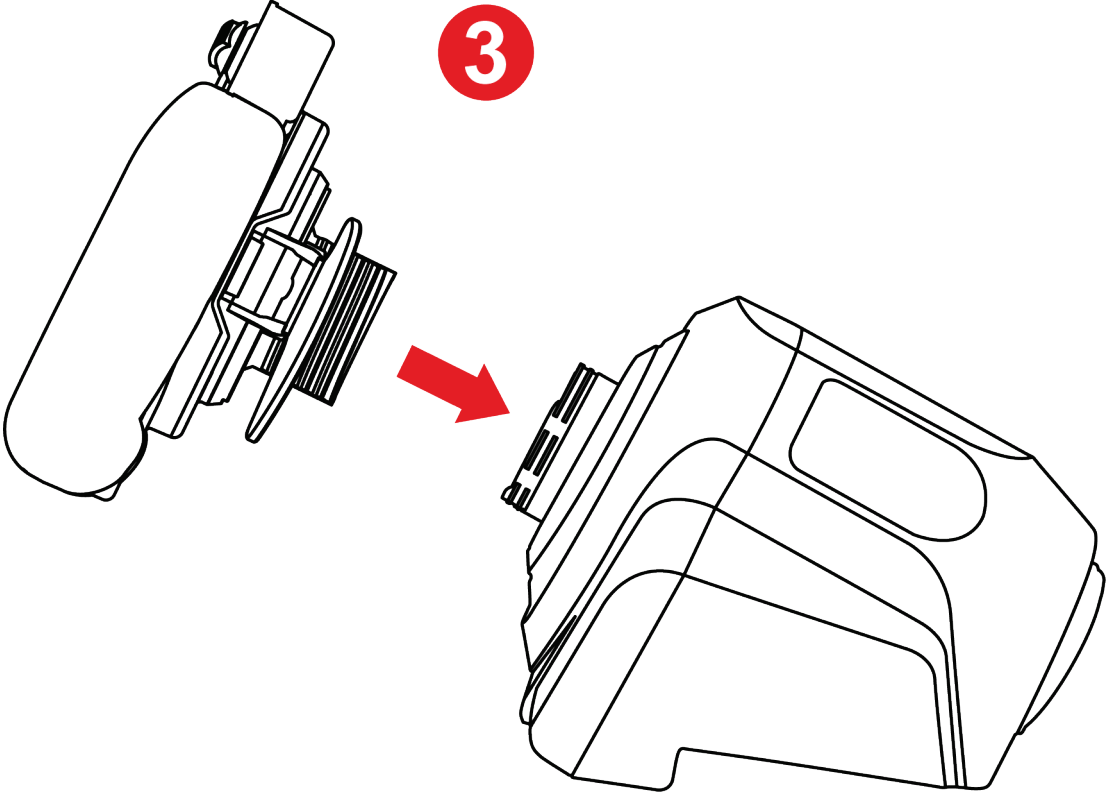

3 Direksiyonu tabana monte edin.



Tabanın kullanıcı kılavuzunda belirtilen montaj prosedürünü izleyin.



T818 tabanda kullanmayı düşünüyorsanız Hızlı Ayırma Adaptörünü (T818 tabanla verilir ve ayrı olarak satılır) asla vidalı taban hızlı ayırmalı tutucuya bağlamayın.

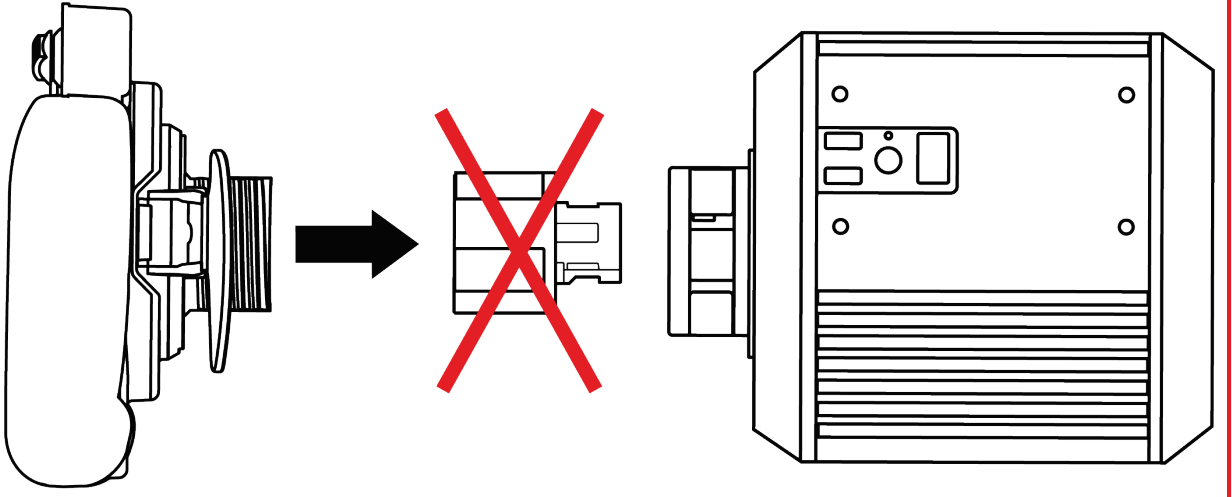
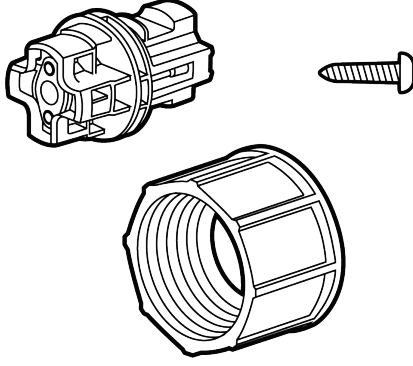

T818 tabanda veya mandallı taban konektörü ile donatılmış tabanda kullanmak için sadece **Ferrari 488 GT3 Wheel Add-On** ile verilen **mandallı taban hızlı ayırmalı tutucuyu** kullanın.



5. Eşleştirme

PC için eşleştirme

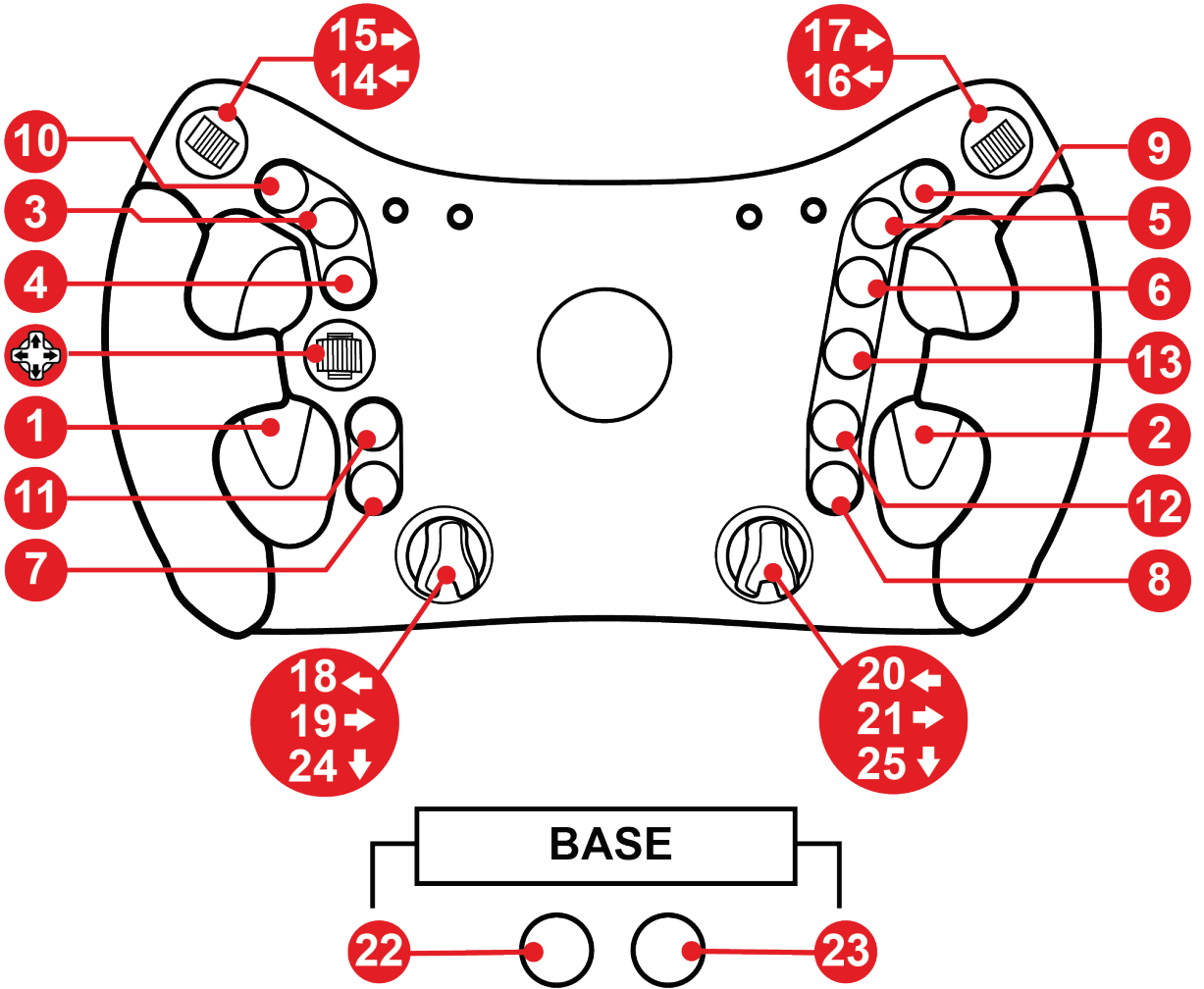



PS4™/PS5™ için eşleştirme

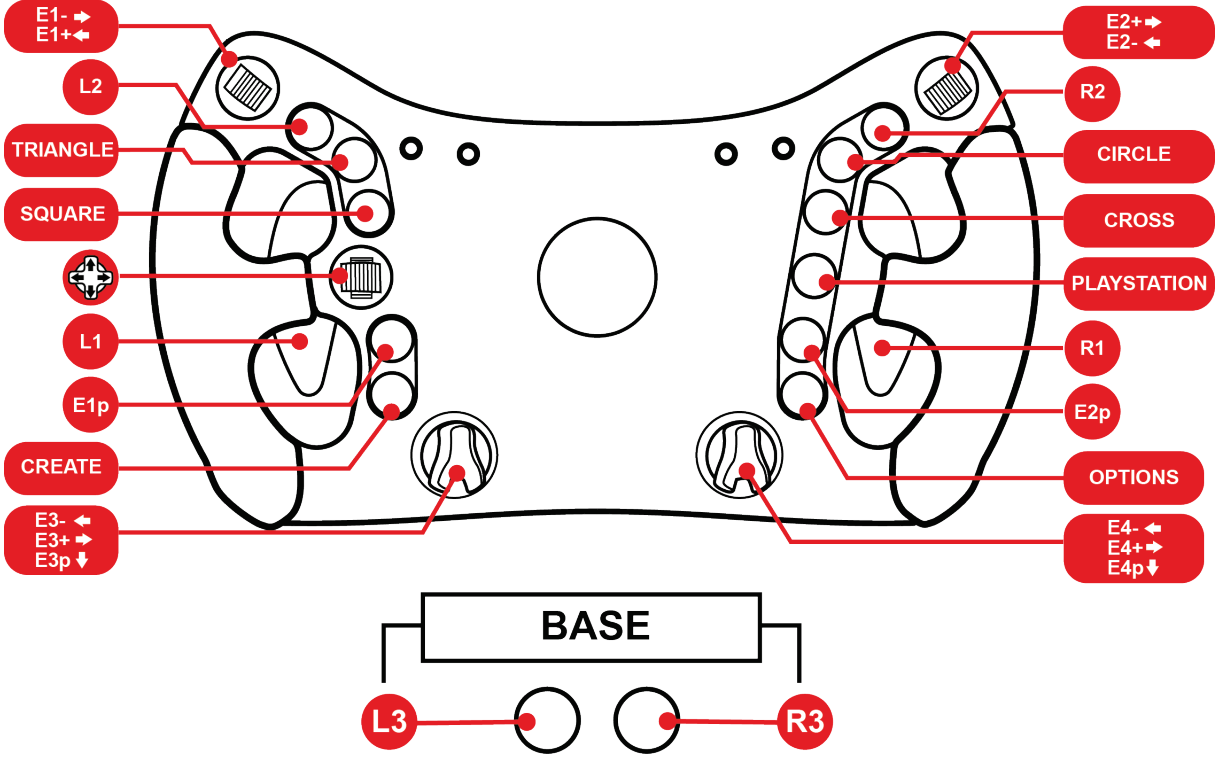



Xbox Series/Xbox One için eşleştirme

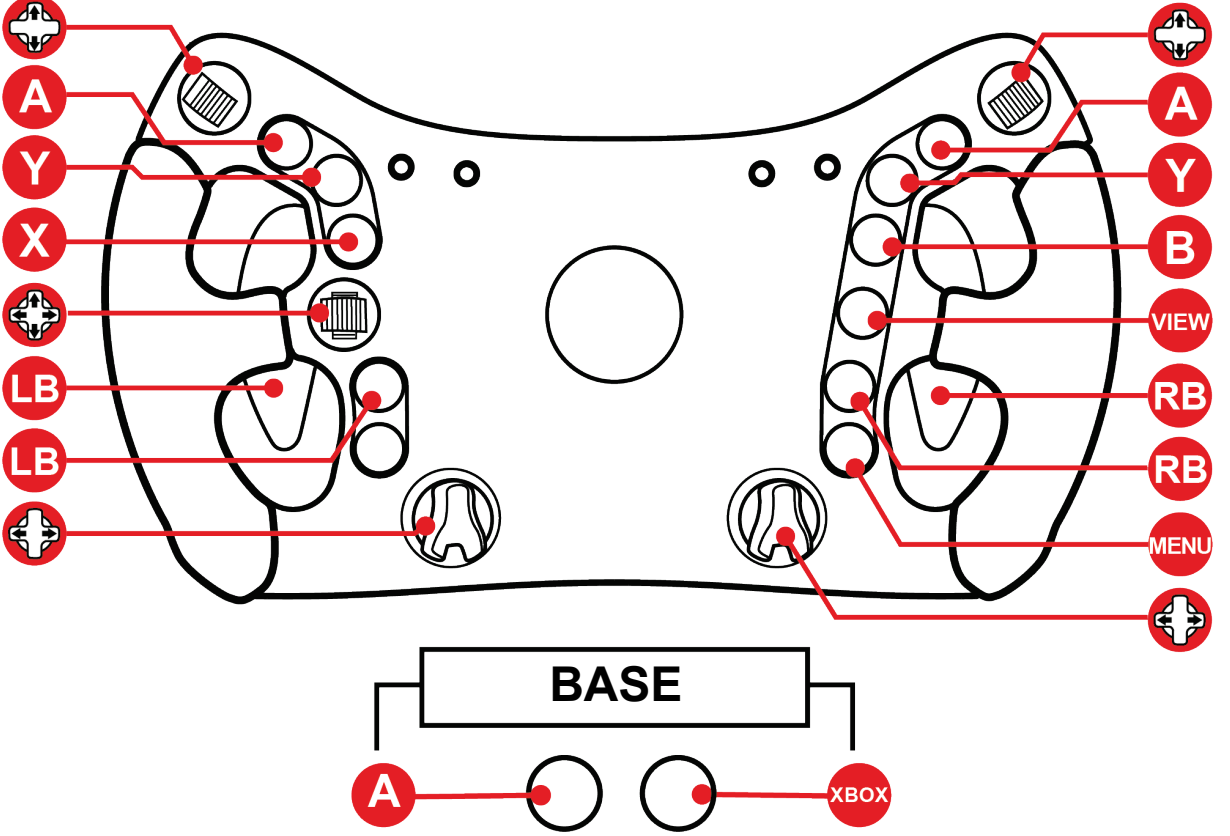

Xbox Series ve Xbox One'da:

- Ferrari 488 GT3 Wheel Add-On üzerindeki LED'ler, konsol protokolü kısıtlamaları nedeniyle işlevsel değildir.
- Bazı işlevler (enkoderler, düğme sayısı) konsol protokolü tarafından sınırlanmaktadır.



6. LED çalışması

Ferrari 488 GT3 Wheel Add-On LED'ler aracılığıyla yarış bilgilerini gösterir: bayrak, pit ve devir.

Gösterilen bilgiler, moda bağlı olarak (GT3 veya Formula) özelleştirilebilir (devir LED'lerinin şiddeti ve rengi).

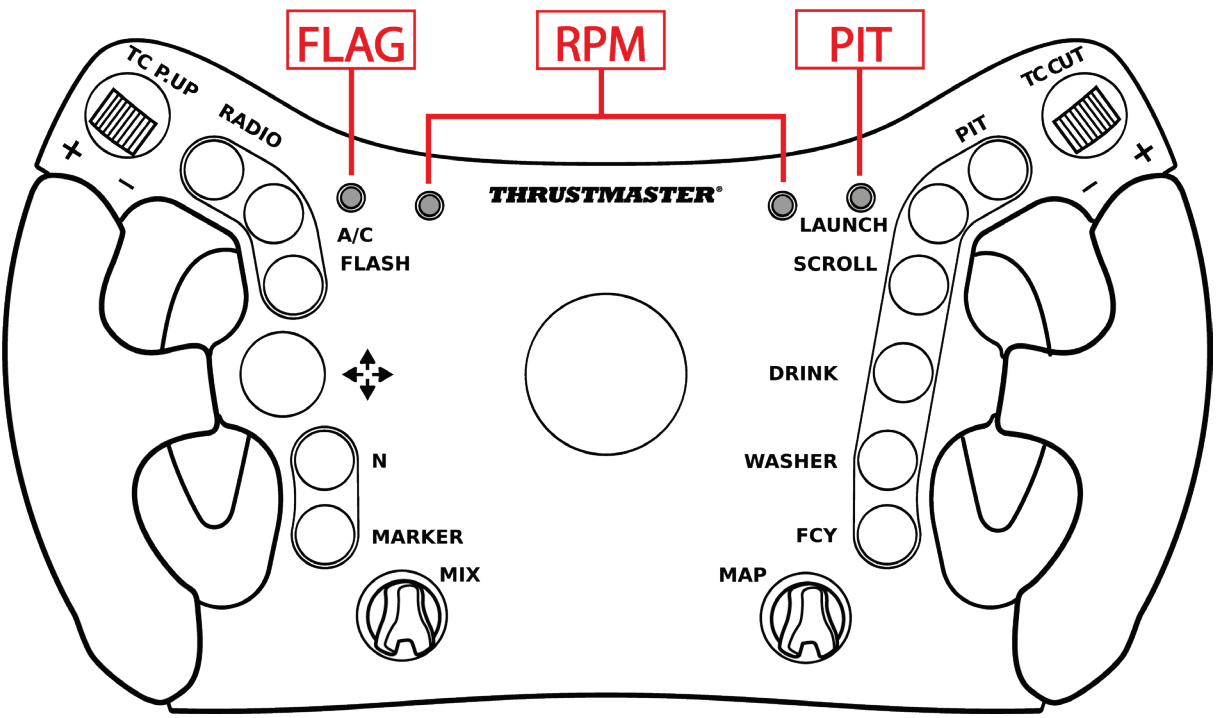

LED'ler PC ve PS4™/PS5™'te işlevseldir.

Xbox Series ve Xbox One'da LED'ler konsol protokolü kısıtlamaları nedeniyle işlevsel değildir.



LED menüsüne girme/çıkma

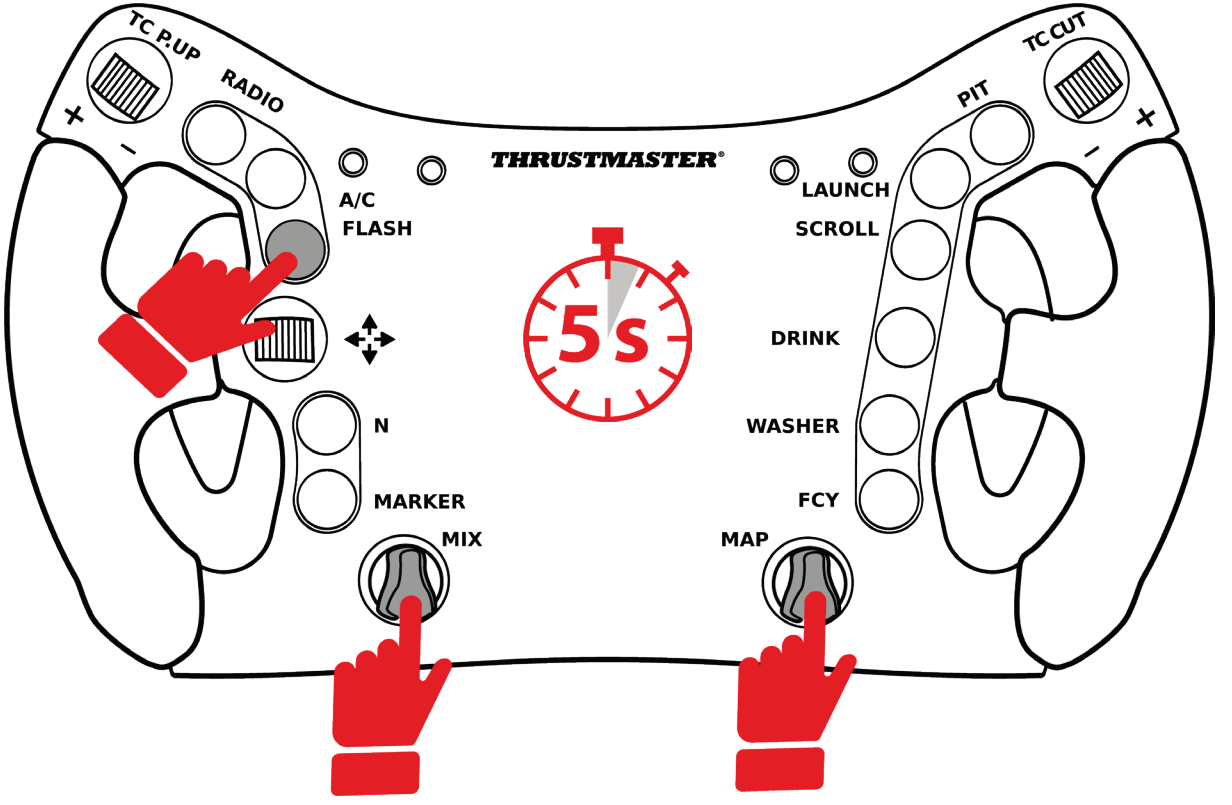

- LED menüsüne girmek için aynı anda **FLASH** düğmesine ve her iki **döner enkodere 5 saniye süreyle** basıp bırakın.

- LED menüsünden çıkmak için aynı anda **FLASH** düğmesine ve her iki **döner enkodere** basıp bırakın.

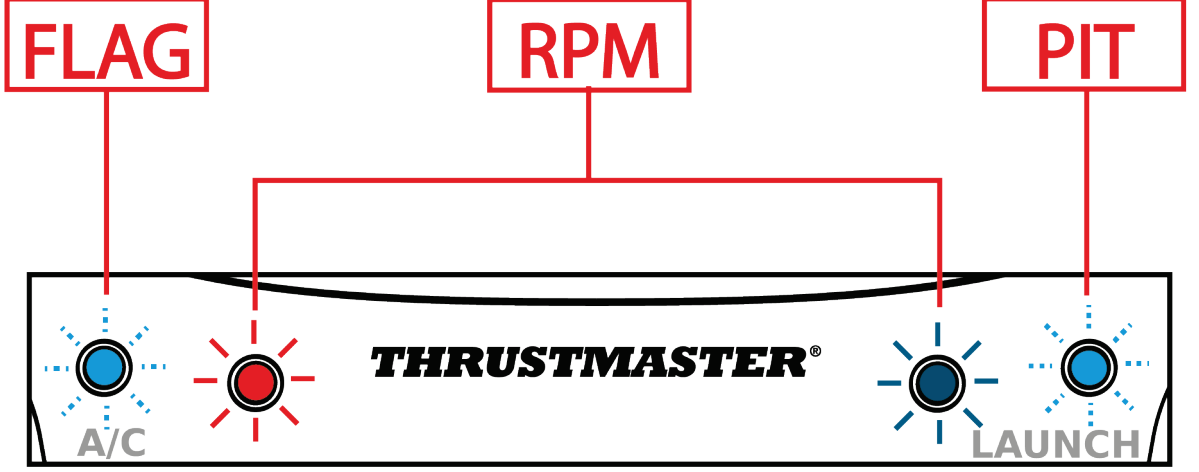

LED menüsüne girildiğinde: FLAG ve PIT LED'leri ile devir LED'lerinin biri (soldaki kırmızı veya sağdaki mavi) yanar.



LED menüsünden çıkıldığında: dört LED'in hepsi kapanır.



LED şiddetini ayarlama

- Aynı anda **FLASH** düğmesine ve her iki **döner enkodere 5 saniye süreyle** basıp bırakarak LED menüsüne girin.
- **Sol enkoderi (MIX)** şiddeti azaltmak için sola, şiddeti artırmak için sağa çevirin.

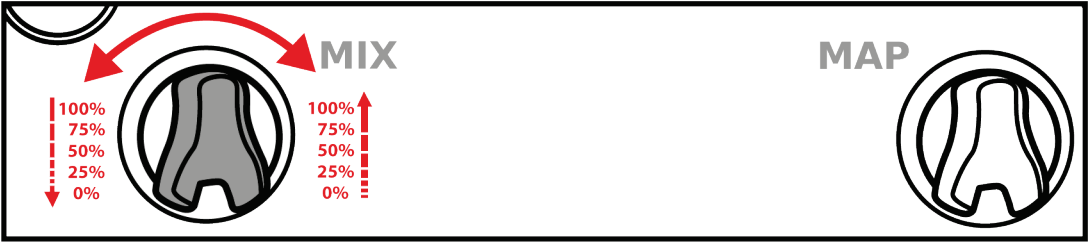

- Aynı anda **FLASH** düğmesine ve her iki **döner enkodere** basıp bırakarak LED menüsünden çıkın.



LED modunu deęiřtirme: GT3 veya Formula

- Aynı anda **FLASH** düęmesine ve her iki **döner enkodere 5 saniye süreyle** basıp bırakarak LED menüsüne girin.
- **Saę enkoderi (MAP)** GT3 modunu (kırmızı LED) seçmek için sola veya Formula modunu (mavi LED) seçmek için saęa çevirin.



GT3 modu (varsayılan mod)



FORMULA modu

- Aynı anda **FLASH** düęmesine ve her iki **döner enkodere** basıp bırakarak LED menüsünden çıkın.



7. Vites kulakçıklarını özelleştirme

Ferrari 488 GT3 Wheel Add-On'un vites kulakçıkları, **ara boşluğu** ve **erim** açısından ayarlanabilir.

Ara boşluğu, vites kulakçıklarının genişlik olarak ayarlanmasını içerir; bu da kavrama yüzeyi ile vites kulakçıkları arasındaki mesafeyi değiştirir.

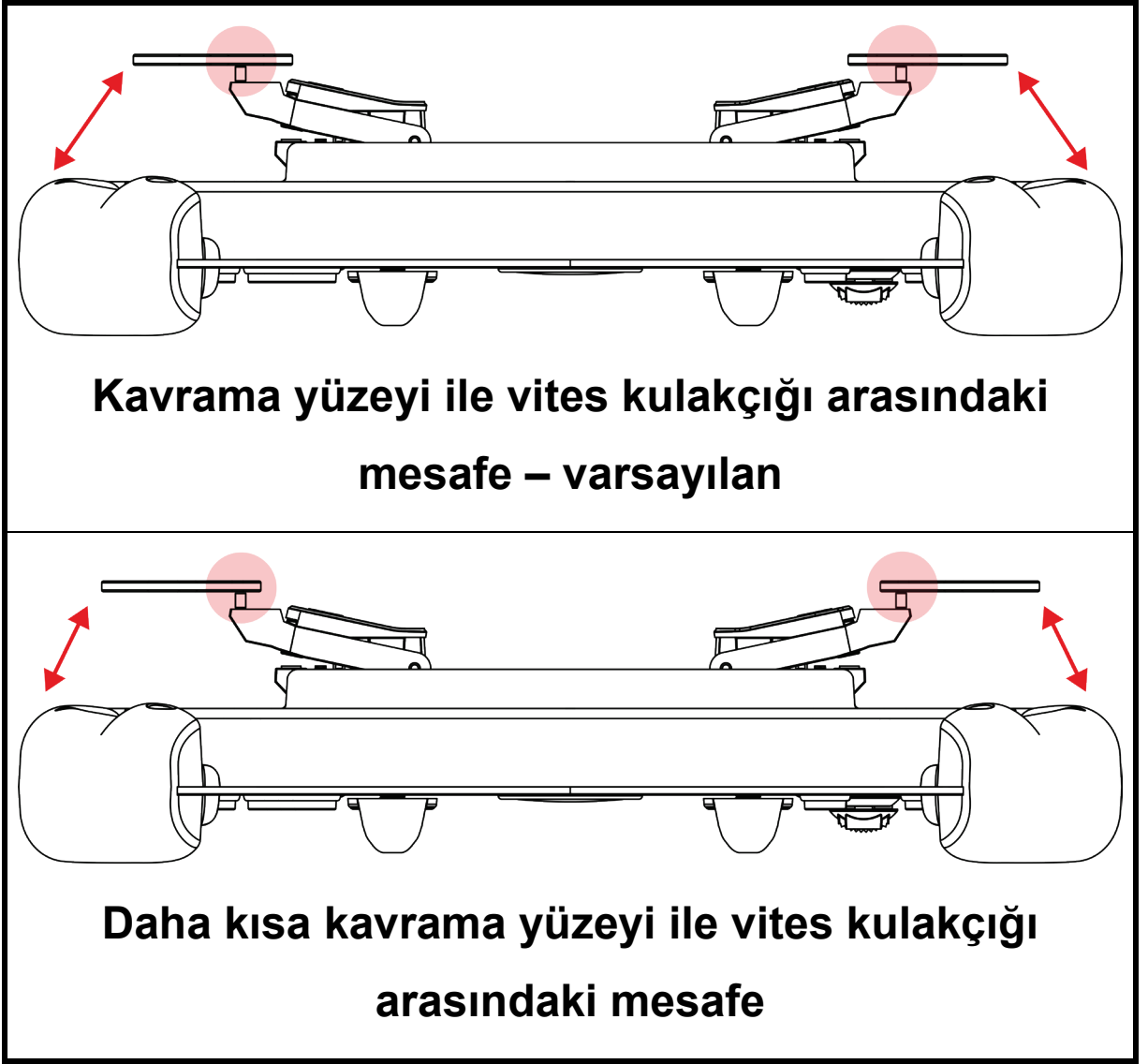



Ara parçaları kullanarak **erimin** ayarlanması, vites kulakçığı aktivasyon mesafesini deęiřtirir.

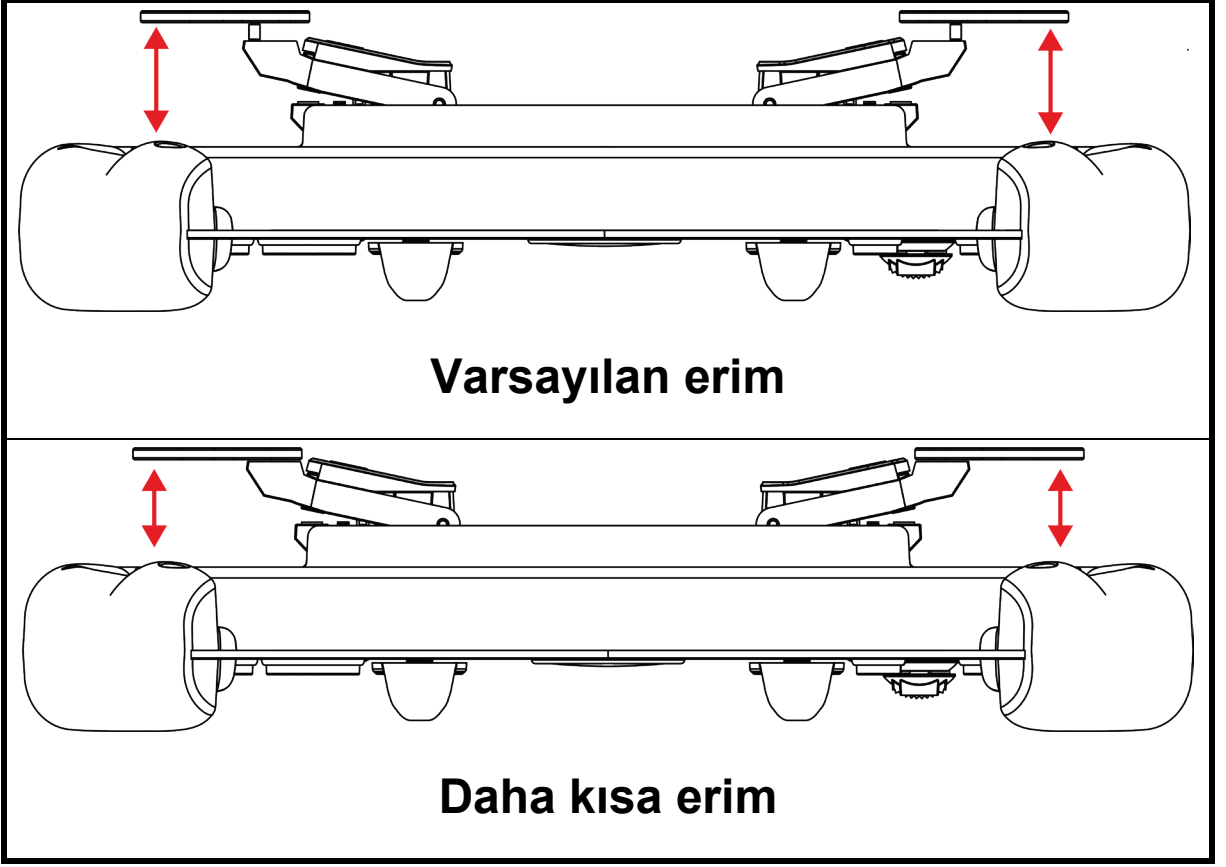

Manyetik hassasiyeti ve vites kulakçıklarının ürettięi **ses seviyesini** verilen tampon setini kullanarak ayarlamak da mümkündür.

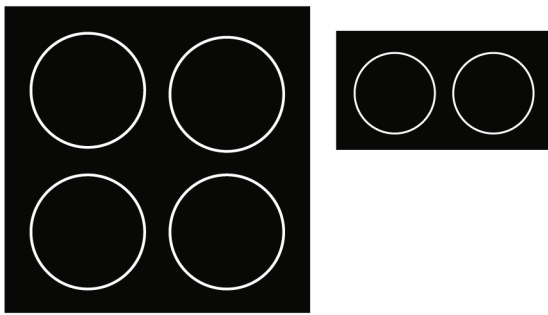



Vites kulakçığı ara boşluğunu ayarlama

1

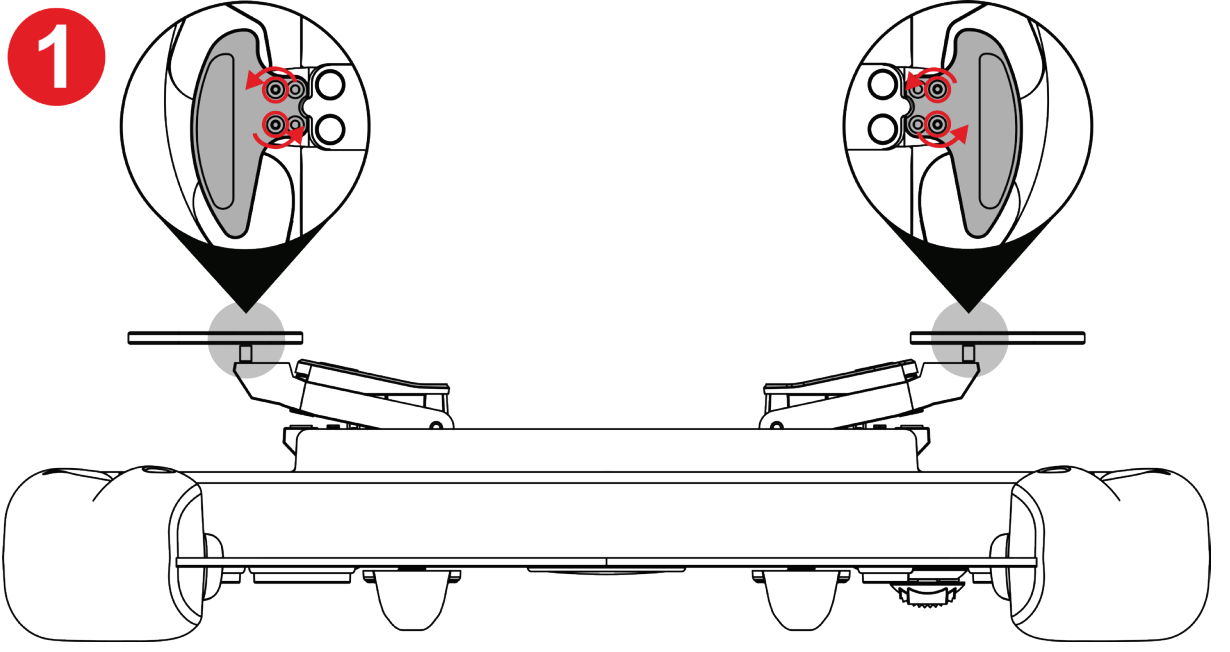

1 Verilen Torx anahtarını kullanarak dört vites kulakçığı vidasını sökün.

2

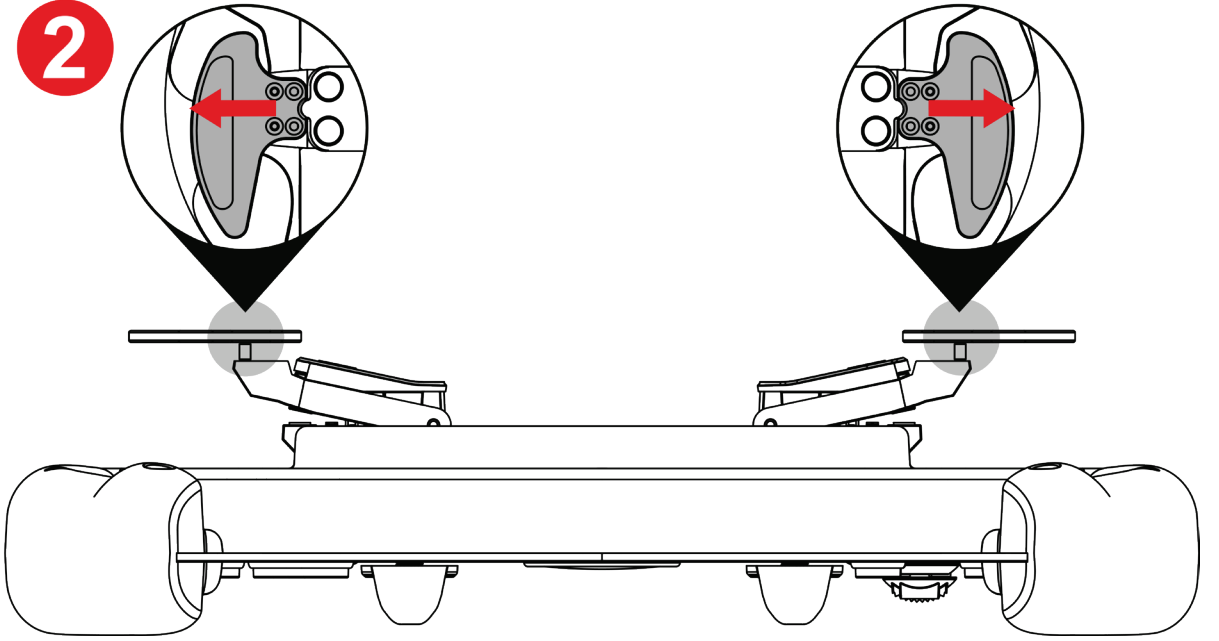

2 Vites kulakçıklarını dışarı doğru kaydırarak deliklerle aynı hizaya getirin.

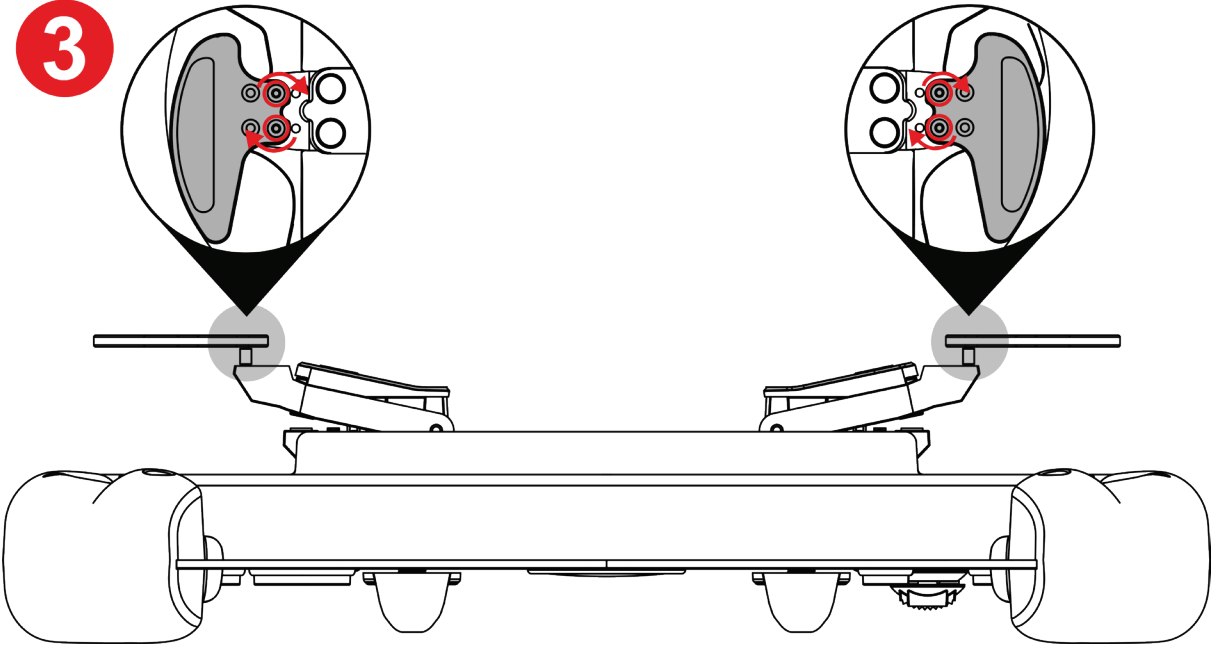

3 Verilen Torx anahtarını kullanarak dört vites kulakçığı vidasını sıkın.



Vites kulakçığı erimini ayarlama

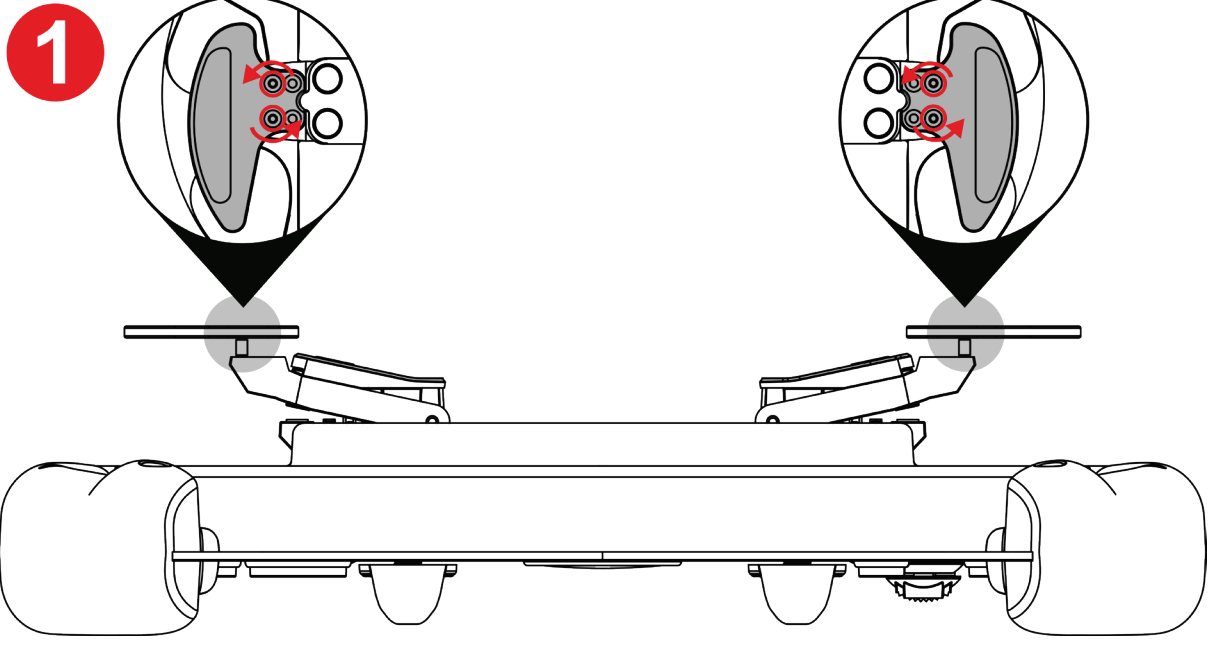

1 Verilen Torx anahtarını kullanarak dört vites kulakçığı vidasını sökün.

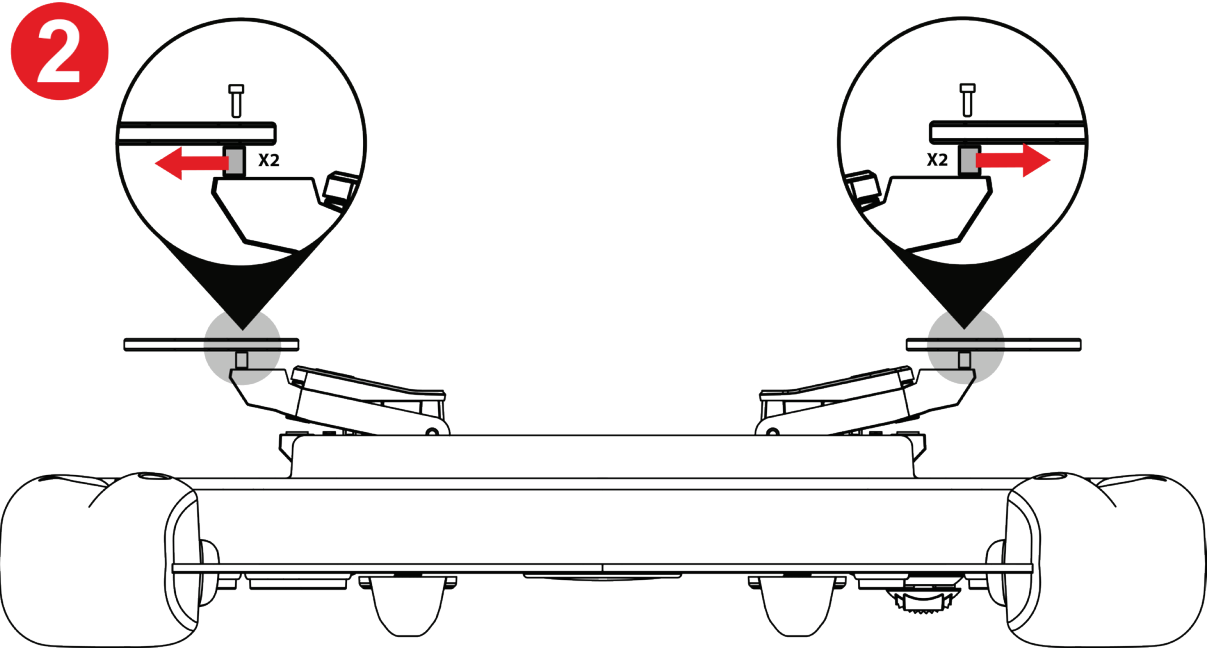

2 Ara parçaları çıkarın.

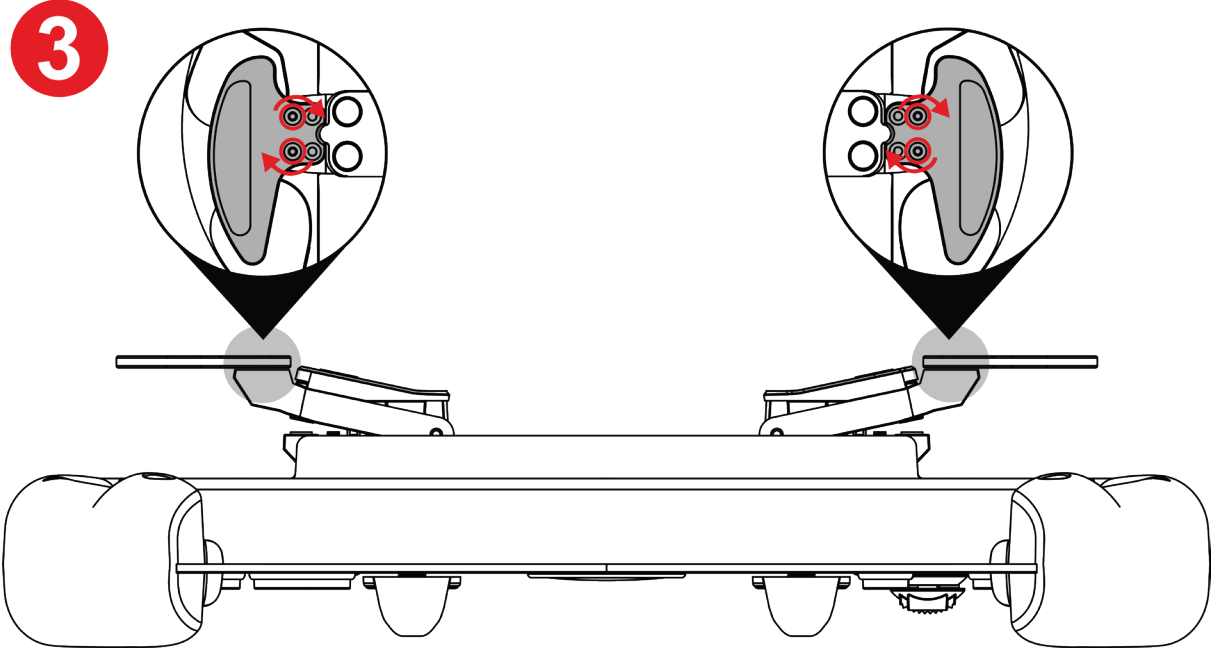

3 Verilen Torx anahtarını kullanarak dört vites kulakçığı vidasını sıkın.



Vites kulakçıklarının manyetik hassasiyetini ve ses seviyesini ayarlama

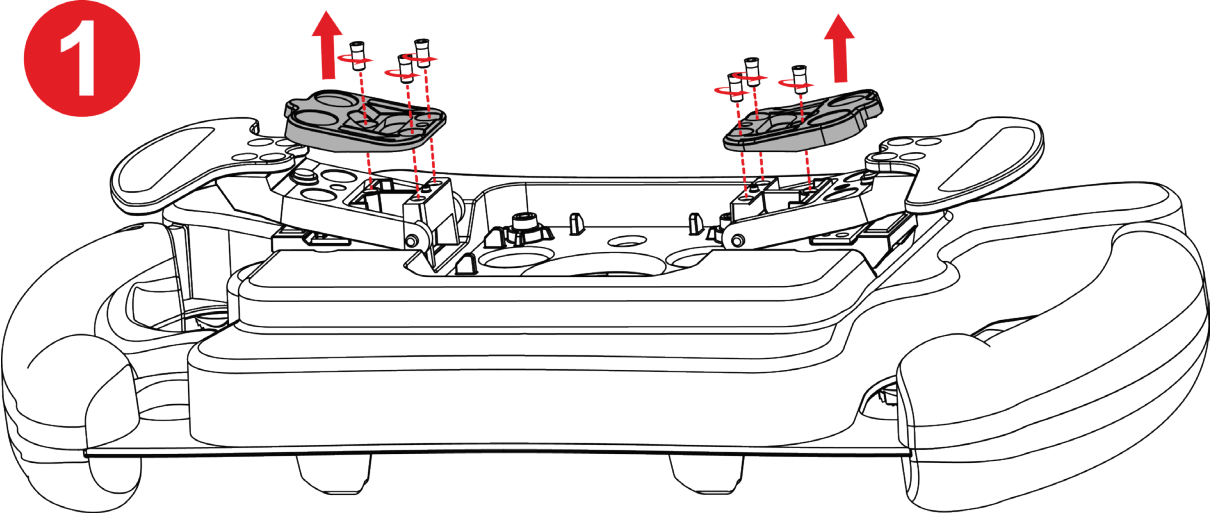

1 Verilen Torx anahtarını kullanarak altı durak vidasını sökmek suretiyle manyetik durakları çıkarın.

2

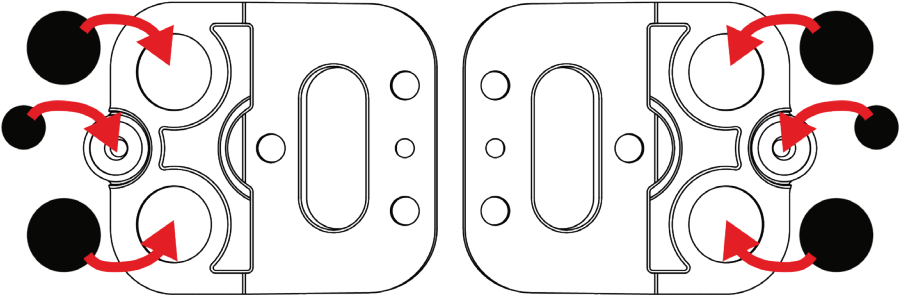
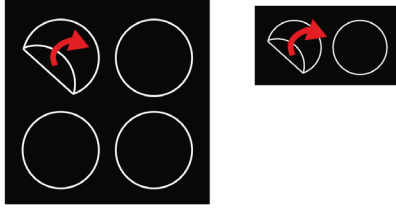

2 Verilen tamponları sıyırın ve manyetik durakların altındaki uygun yerlere yapıştırın.



Olası konfigürasyonlar ve etkileri için bkz. **Manyetik hassasiyet ve vites kulakçığı ses azaltma tablosu.**



3

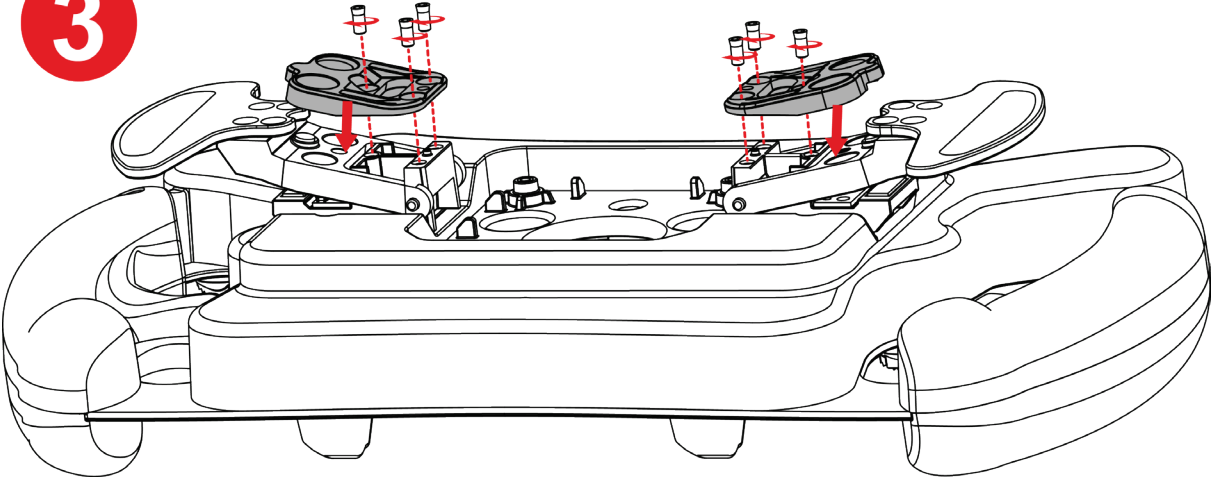

3 Manyetik durakları yeniden takın ve verilen Torx anahtarını kullanarak altı durak vidasını sıkın.

Manyetik hassasiyet ve vites kulakçığı ses azaltma tablosu

	 (varsayılan)		
Manyetik hassasiyet			
Ses			



8. SSS ve teknik destek

Ferrari 488 GT3 Wheel Add-On ile ilgili sorularınız mı var veya teknik sorunlarla mı karşılaştınız? Öyleyse Thrustmaster teknik destek web sitesini ziyaret edin:

<https://support.thrustmaster.com/product/ferrarif488gt3addon>.

Bu sayfadan direksiyonun donanım yazılımını da güncelleyebilirsiniz.



THRUSTMASTER®

FERRARI 488 GT3 WHEEL ADD-ON

PC (Windows 10/11)

PS4™ / PS5™

Xbox Series / Xbox One

Instrukcja obsługi



Przed zainstalowaniem urządzenia, **przed** każdym jego użyciem i **przed** wykonaniem jakichkolwiek czynności konserwacyjnych **uważnie przeczytaj** wskazówki zawarte w niniejszej instrukcji. Koniecznie przestrzegaj wskazówek dotyczących bezpieczeństwa. Nieprzestrzeganie tych wskazówek może prowadzić do wypadków i/lub uszkodzeń. Zachowaj tę instrukcję do ewentualnego użycia w przyszłości.

SPIS TREŚCI

1.	ZAWARTOŚĆ OPAKOWANIA.....	5
2.	ELEMENTY	6
3.	INFORMACJE NA TEMAT KORZYSTANIA Z KIEROWNICY.....	8
4.	INSTALACJA UCHWYTU SZYBKOROZŁĄCZNEGO	13
	<i>Instalacja uchwytu szybkorozłącznego do podstawy z zatrzaskiem.....</i>	<i>14</i>
	<i>Instalacja uchwytu szybkorozłącznego do podstawy z gwintem</i>	<i>17</i>
5.	MAPOWANIE.....	21
	<i>Mapowanie na komputerze PC.....</i>	<i>21</i>
	<i>Mapowanie na konsoli PS4™/PS5™</i>	<i>22</i>
	<i>Mapowanie na konsoli Xbox Series/Xbox One</i>	<i>23</i>
6.	DZIAŁANIE DIOD	24
	<i>Jak wejść/wyjść z menu diod.....</i>	<i>25</i>

Jak dostosować natężenie diod27

Jak zmienić tryb diod: GT3 lub

Formuła28

7. DOSTOSOWYWANIE ŁOPATEK ZMIANY

BIEGÓW29

Jak dostosować odstęp łopatek zmiany

biegów31

Jak dostosować zakres ruchu łopatek

zmiany biegów33

Jak dostosować czułość magnetyczną

i poziom dźwięku łopatek zmiany

biegów35

8. CZĘSTO ZADAWANE PYTANIA I POMOC

TECHNICZNA.....37



FERRARI 488 GT3 WHEEL ADD-ON

Weź udział w legendarnych wyścigach GT z kierownicą Ferrari 488 GT3 Wheel Add-On, która została zaprojektowana z myślą o najwyższych osiągnięciach i jest zgodna ze wszystkimi podstawami kierownic Thrustmaster.

Niniejsza instrukcja pomoże Ci w optymalnej instalacji i eksploatacji kierownicy Ferrari 488 GT3 Wheel Add-On. Zanim przystąpisz do wyścigów, uważnie zapoznaj się ze wskazówkami i ostrzeżeniami, które pomogą Ci czerpać maksymalną przyjemność z użytkowania urządzenia.



1. Zawartość opakowania

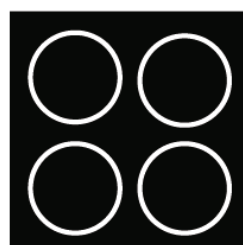
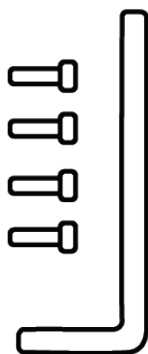
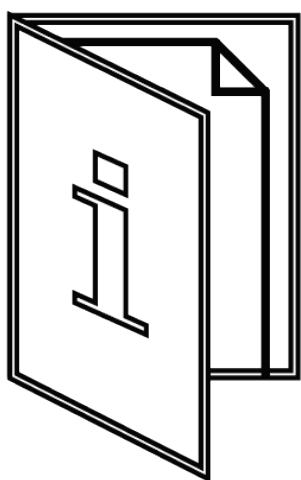
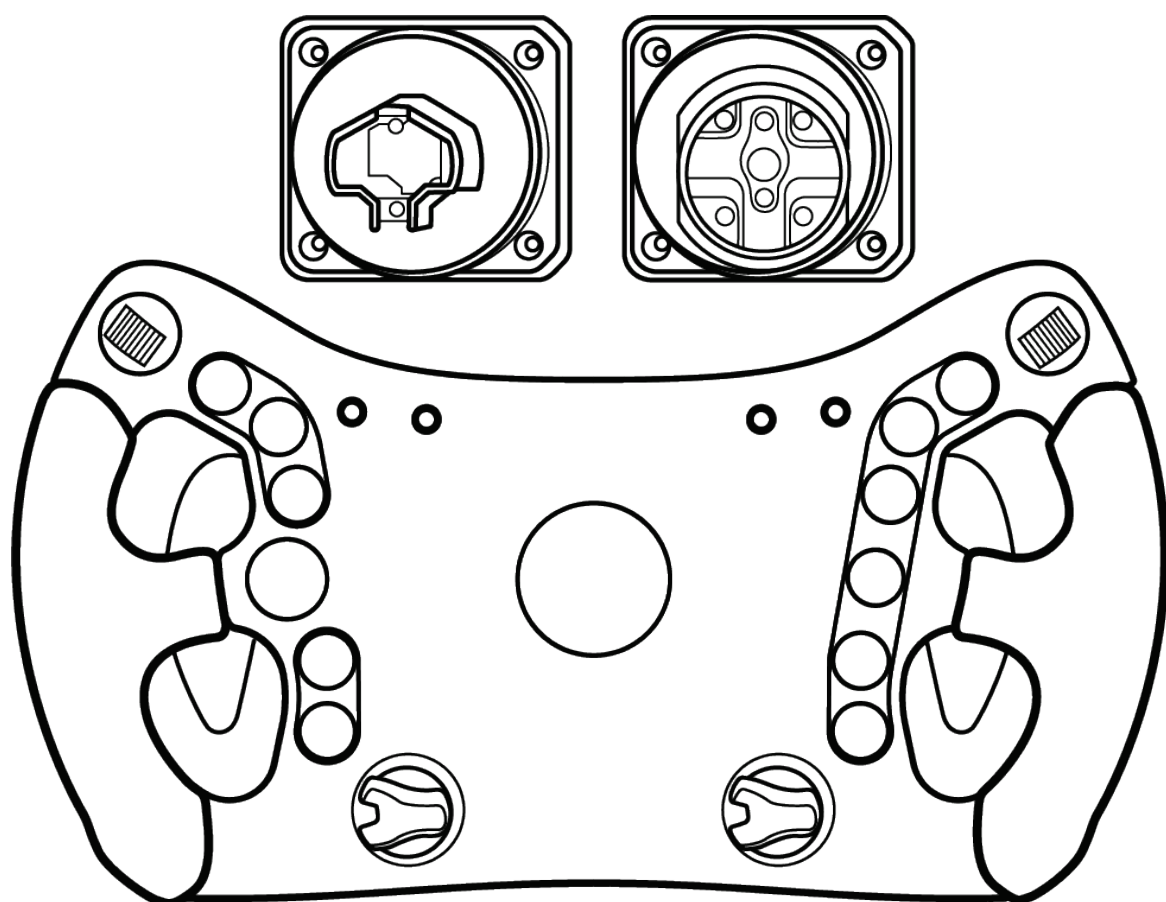



2. Elementy

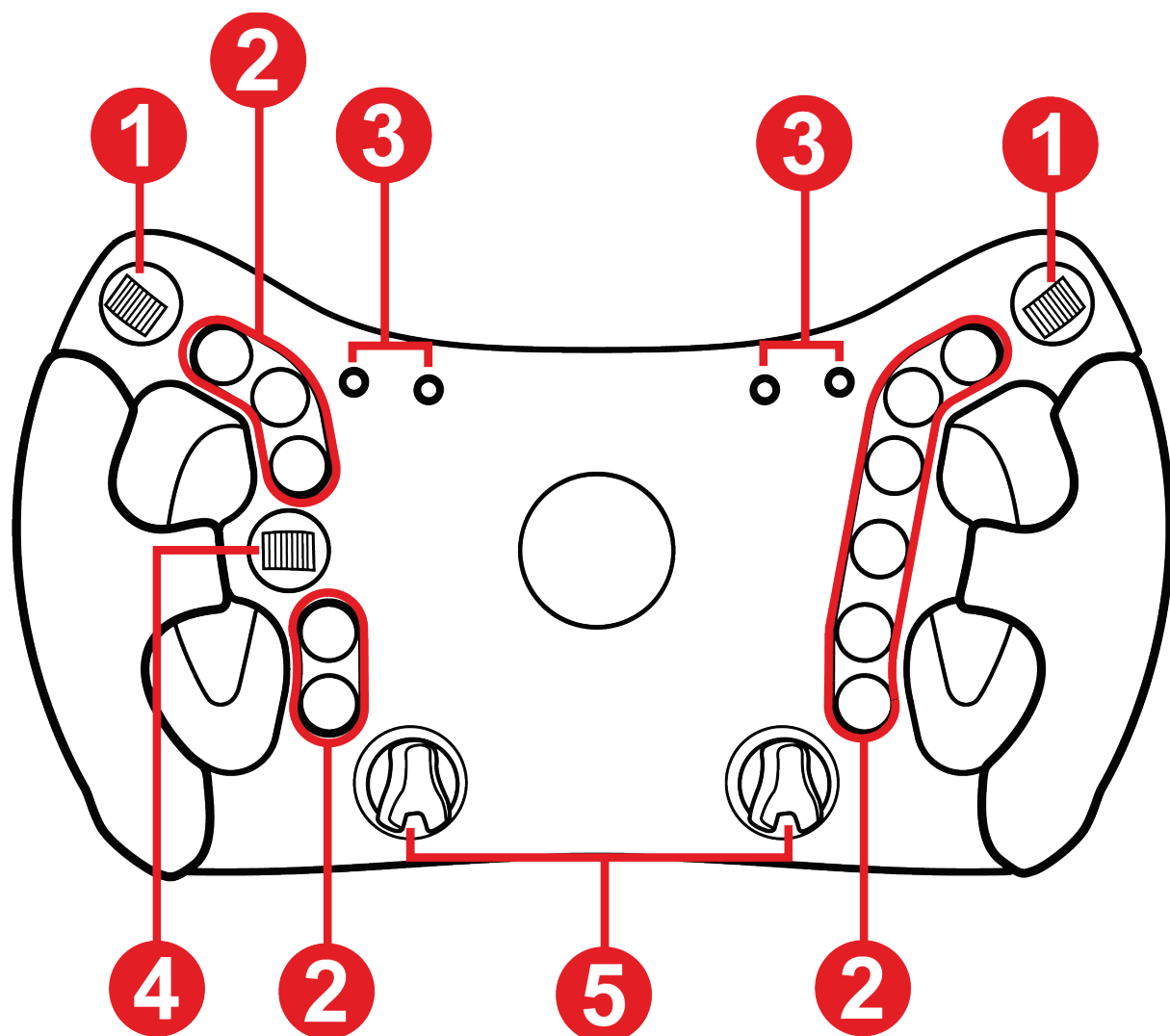

❶ Kodery kciukowe

❷ 11 przycisków czynności

❸ Diody wskazujące prędkość obrotową i dane wyścigu (flagi, pit-stop)

❹ D-pad

❺ Pokręta kodujące

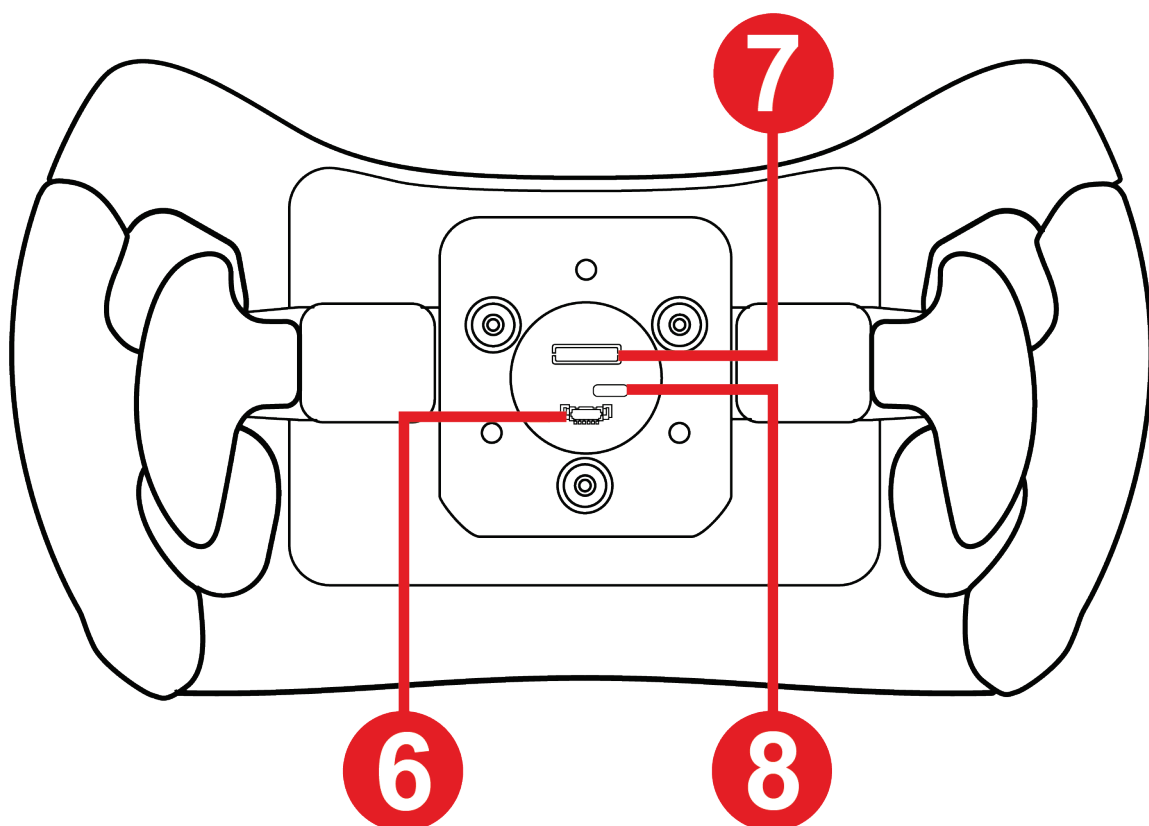

⑥ Port połączeniowy uchwyty szybkozłącznego do podstawy z gwintem

⑦ Port połączeniowy uchwyty szybkozłącznego do podstawy z zatrzaskiem

⑧ Port USB-C (do aktualizowania oprogramowania sprzętowego — kabel do nabycia osobno)

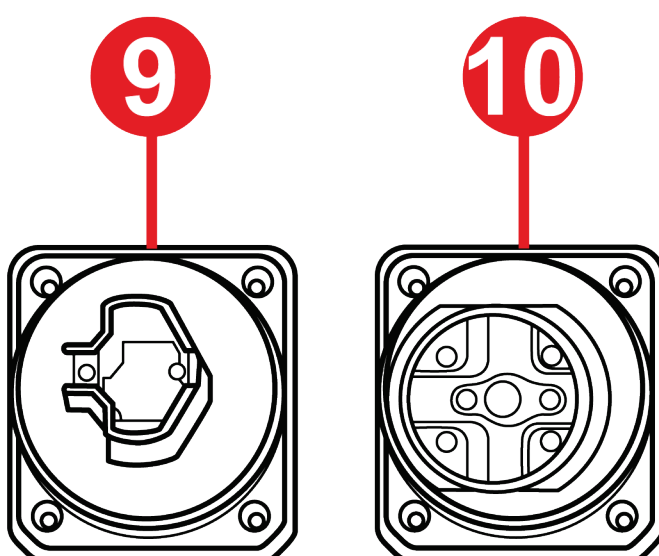

⑨ Uchwyt szybkozłączny do podstawy z zatrzaskiem

⑩ Uchwyt szybkozłączny do podstawy z gwintem



3. Informacje na temat korzystania z kierownicy



Dokumentacja

Zanim rozpoczniesz korzystanie z urządzenia, jeszcze raz uważnie zapoznaj się z tym dokumentem, a następnie zachowaj go do wglądu.



Porażenie prądem elektrycznym

- Przechowuj urządzenie w suchym miejscu i nie wystawiaj go na działanie kurzu ani światła słonecznego.
- Nie skręcaj ani nie naciągaj złączy ani kabli.
- Przestrzegaj właściwego kierunku połączeń.
- Nie wylewaj cieczy na urządzenie ani jego złącza.
- Nie zwieraj urządzenia.
- Nie demontuj urządzenia (poza ewentualnymi dostosowaniami określonymi w tej instrukcji), nie wrzucaj go do ognia ani nie narażaj na działanie wysokich temperatur.
- Nie otwieraj urządzenia: w jego wnętrzu nie ma części przeznaczonych do naprawiania przez użytkownika. Naprawy może wykonywać wyłącznie producent, wskazany przedstawiciel lub wykwalifikowany serwisant.



Zabezpieczenie strefy grania

- Nigdy nie umieszczaj w strefie grania przedmiotów, które mogą zakłócić czynności użytkownika albo wywołać nieodpowiedni ruch lub przerwę ze strony innej osoby (takich jak kubek z kawą, telefon czy klucze).
- Nie zakrywaj kabli zasilania dywanem, chodnikiem, kocem, narzutą ani innym przedmiotem oraz nie umieszczaj żadnych kabli w miejscach, w których ktoś może chodzić.



Ryzyko obrażeń ciała spowodowanych siłowym sprzężeniem zwrotnym i powtarzającymi się ruchami

Używanie kierownicy z siłowym sprzężeniem zwrotnym może doprowadzić do bólu mięśni lub stawów. W celu uniknięcia problemów:

- Zaczynaj od rozgrzewki i unikaj długich sesji treningowych.
- Po każdej godzinie treningu rób 10–15 minut przerwy.
- Jeśli odczuwasz zmęczenie lub ból dłoni, nadgarstków, ramion, stóp lub nóg, naciśnij przycisk wyłączający siłowe sprzężenie zwrotne, wyłącz podstawę i przed ponownym rozpoczęciem treningu odpocznij kilka godzin.
- Jeśli po ponownym rozpoczęciu treningu opisane powyżej objawy lub bóle powrócą, przerwij trening i poradź się lekarza.
- Nie ustawiaj siłowego sprzężenia zwrotnego na poziomie zbyt wysokim w stosunku do swojego doświadczenia i kondycji fizycznej.
- Nie pozwalaj na dostęp do urządzenia osobom poniżej 16 roku życia.
- Sprawdź, czy podstawa i kierownica są prawidłowo zamocowane zgodnie ze wskazówkami podanymi w instrukcji.



Ryzyko nieprzewidzianych, mocnych i gwałtownych obrotów: nigdy przekładaj dłoni ani ramienia przez otwory w kole kierownicy ani umieszczaj ich w trajektorii obrotu kierownicy.

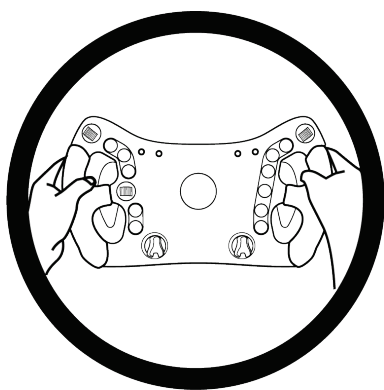

Podczas korzystania z urządzenia zawsze trzymaj obie dłonie we właściwym położeniu na kierownicy, nigdy nie puszczając jej całkowicie.



Urządzenie tylko dla osób, które ukończyły 16 lat.



4. Instalacja uchwytu szybkorozłącznego

Kierownica **Ferrari 488 GT3 Wheel Add-On** jest dostarczana z dwoma uchwytami szybkorozłącznymi, które odpowiadają dwóm formatom podstaw Thrustmaster.

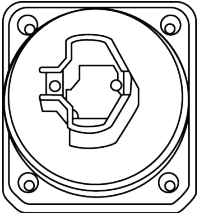
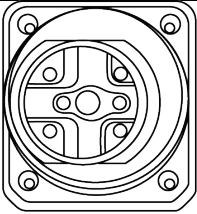
System	Zgodność
 Uchwyt szybkorozłączny do podstawy z zatrzaskiem	T818, T818 Ferrari SF1000 Simulator i przyszłe podstawy Thrustmaster.
 Uchwyt szybkorozłączny do podstawy z gwintem	T-GT / T-GT II Servo Base, T300 RS Servo Base, TS PC Racer, TS-XW, TX Racing Wheel Servo Base, TS-XW Servo Base.



Przed każdym użyciem kierownicy **Ferrari 488 GT3 Wheel Add-On** sprawdź, czy jest ona wciąż prawidłowo przymocowana do podpory zgodnie z instrukcją obsługi podstawy.



Instalacja uchwyty szybkozłącznego do podstawy z zatrzaskiem

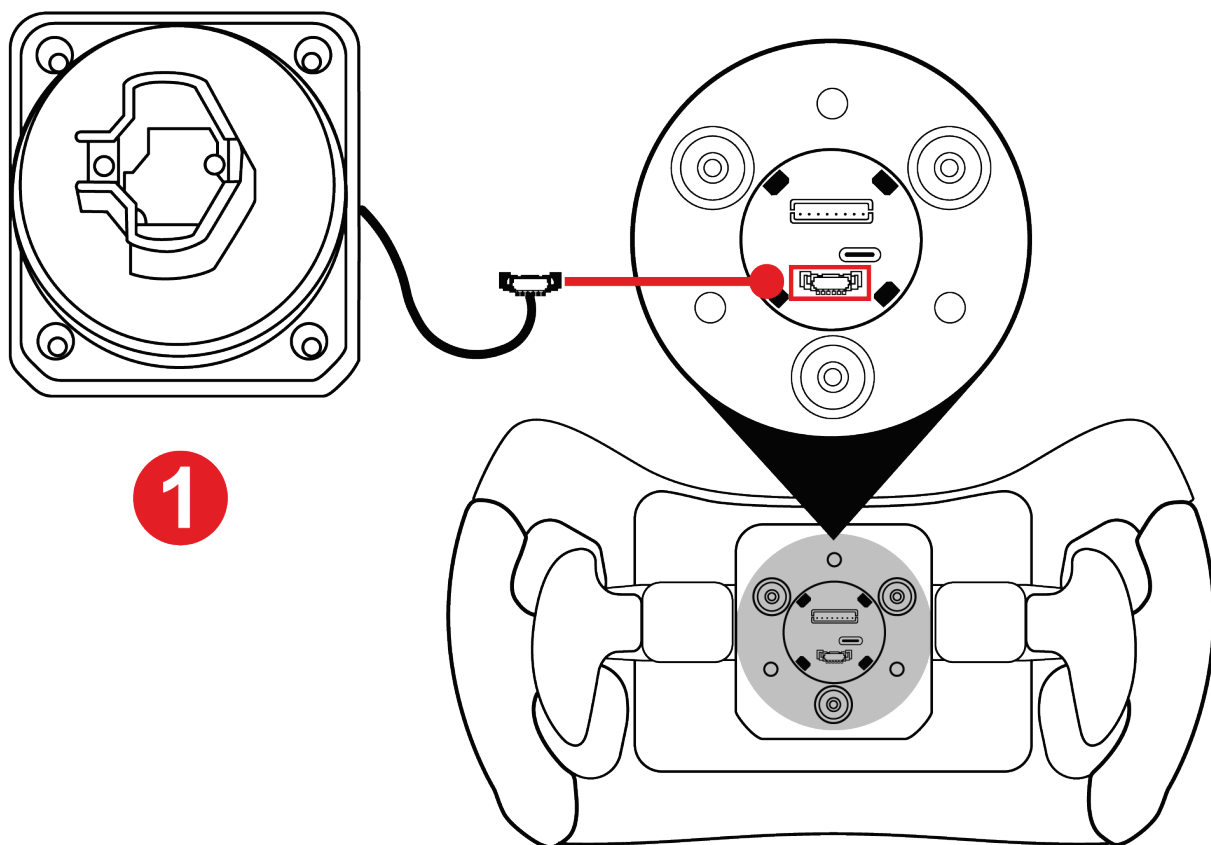

1

1 Włóż złącze uchwyty szybkozłącznego do odpowiedniego portu z tyłu kierownicy.



Aby nie przytrzasnąć kabla, schowaj go do obudowy przed przykręceniem uchwyty.

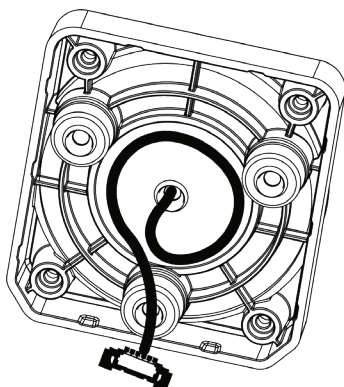

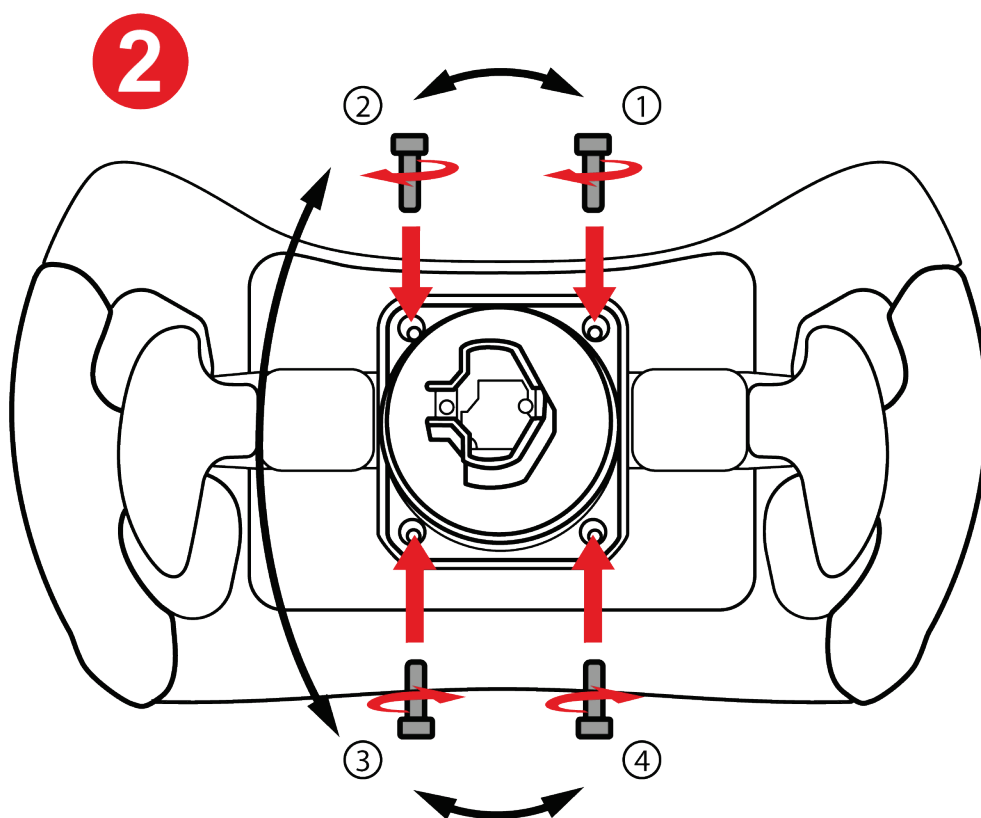

2 Włóż uchwyt szybkorozłączny i przykręć go za pomocą dostarczonego klucza Torx.



Podczas mocowania uchwyту uważaj, aby nie dokręcić śrub zbyt mocno.

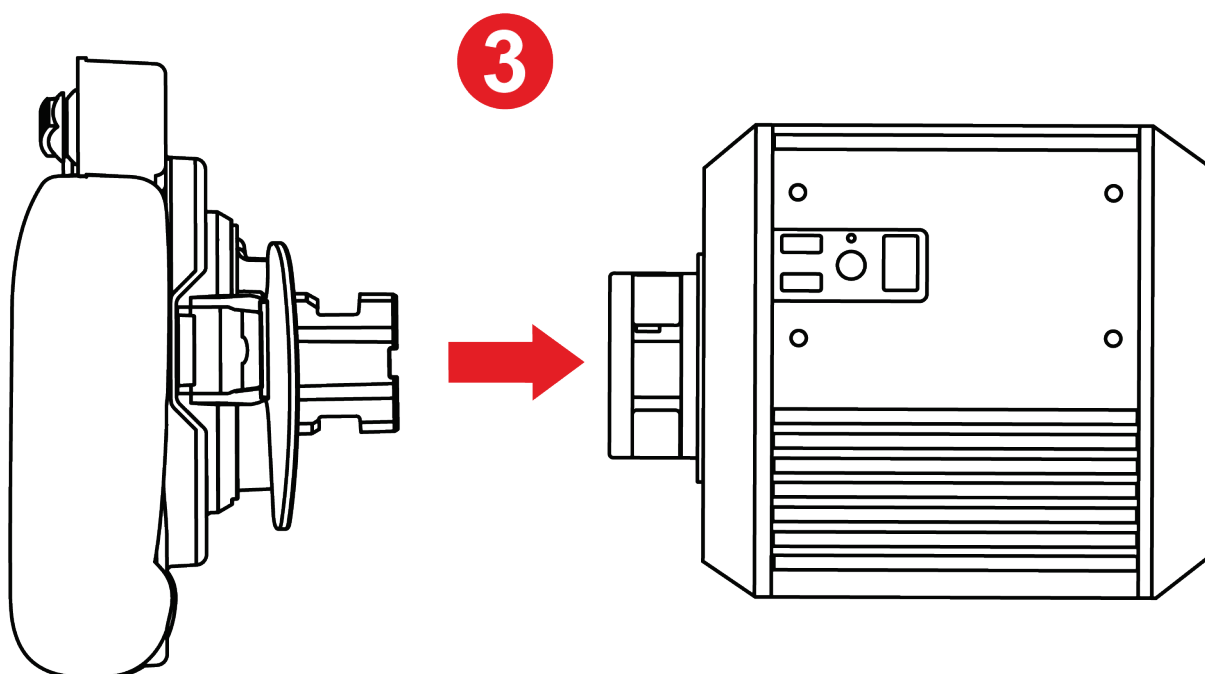

3 Zamocuj kierownicę do podstawy.



Postępuj zgodnie z procedurą instalacji podaną w instrukcji obsługi podstawy.



Instalacja uchwyty szybkozłącznego do podstawy z gwintem

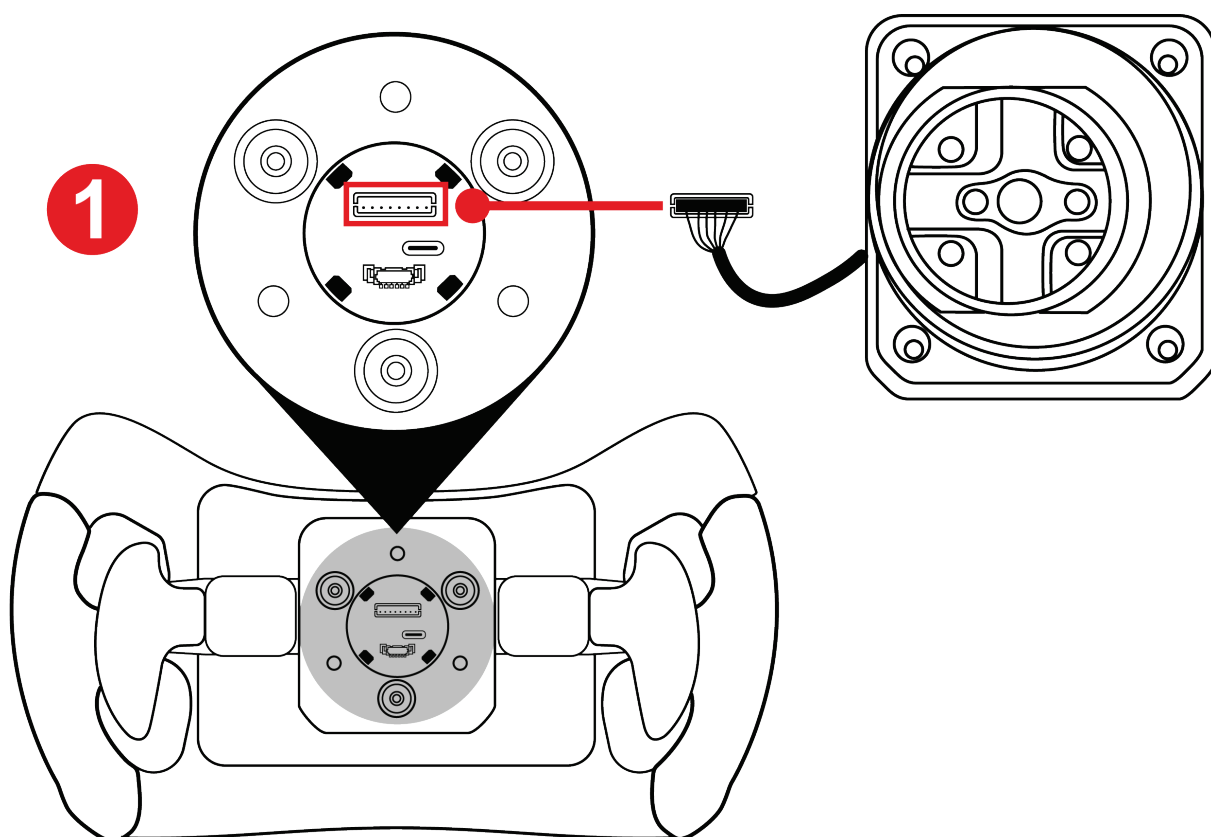

1 Włóż złącze uchwyty szybkozłącznego do odpowiedniego portu z tyłu kierownicy.



Aby nie przytrzasnąć kabla, schowaj go do obudowy przed przykręceniem uchwyty.

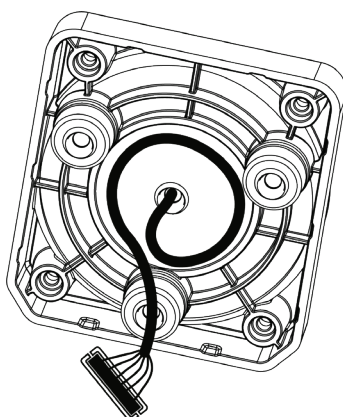

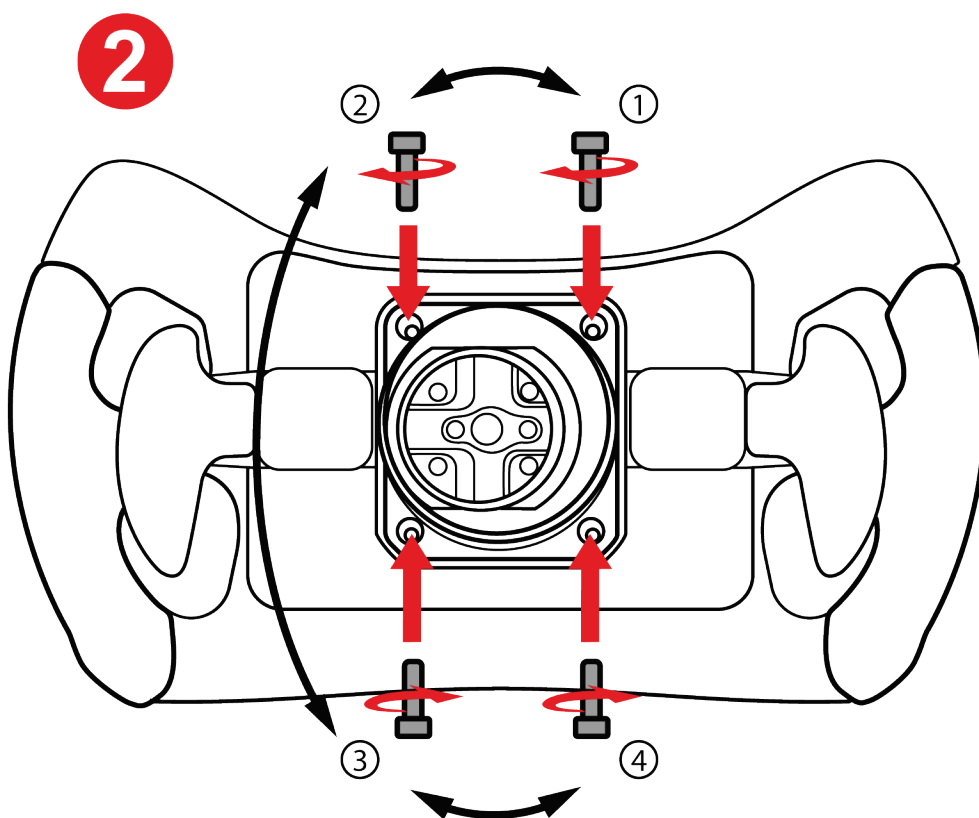

2 Włóż uchwyt szybkorozłączny i przykręć go za pomocą dostarczonego klucza Torx.



Podczas mocowania uchwyty uważaj, aby nie dokręcić śrub zbyt mocno.

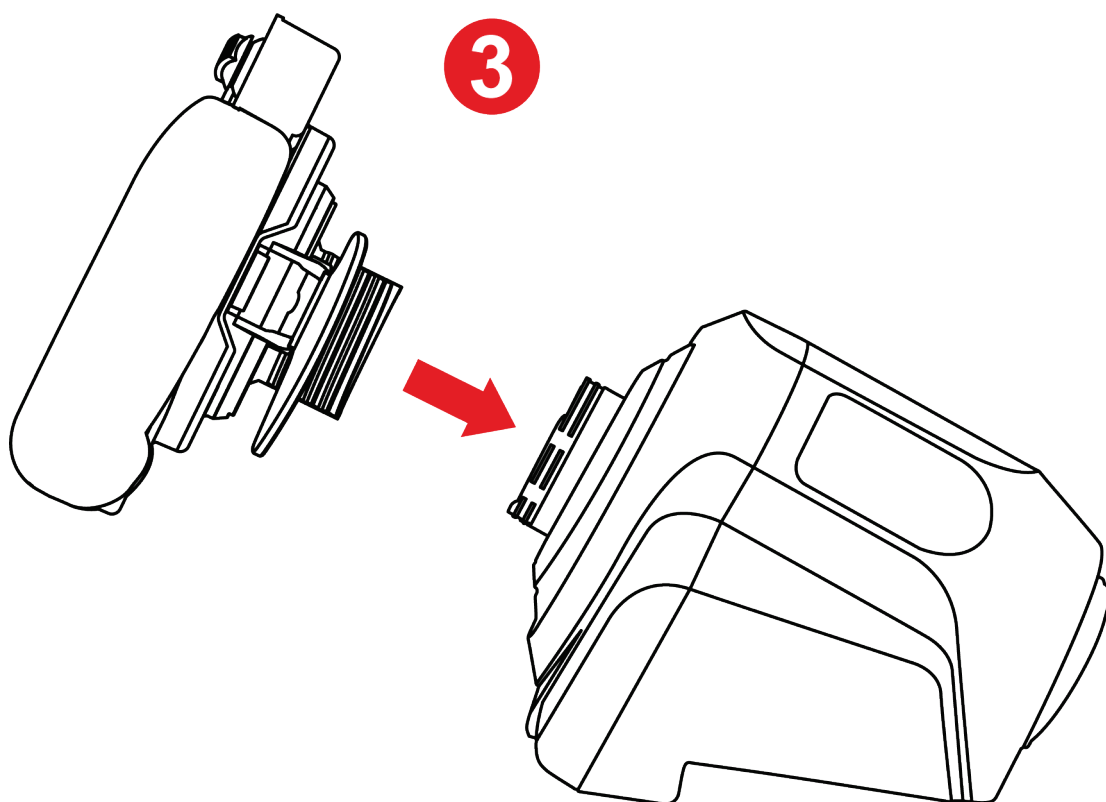

3 Zamocuj kierownicę do podstawy.



Postępuj zgodnie z procedurą instalacji podaną w instrukcji obsługi podstawy.



Nigdy nie podłączaj adaptera układu szybkiej instalacji (dostarczanego z podstawą T818 i sprzedawanego oddzielnie) do uchwyty szybkorozłącznego przeznaczonego do podstawy z gwintem, jeśli chcesz go użyć w podstawie T818.

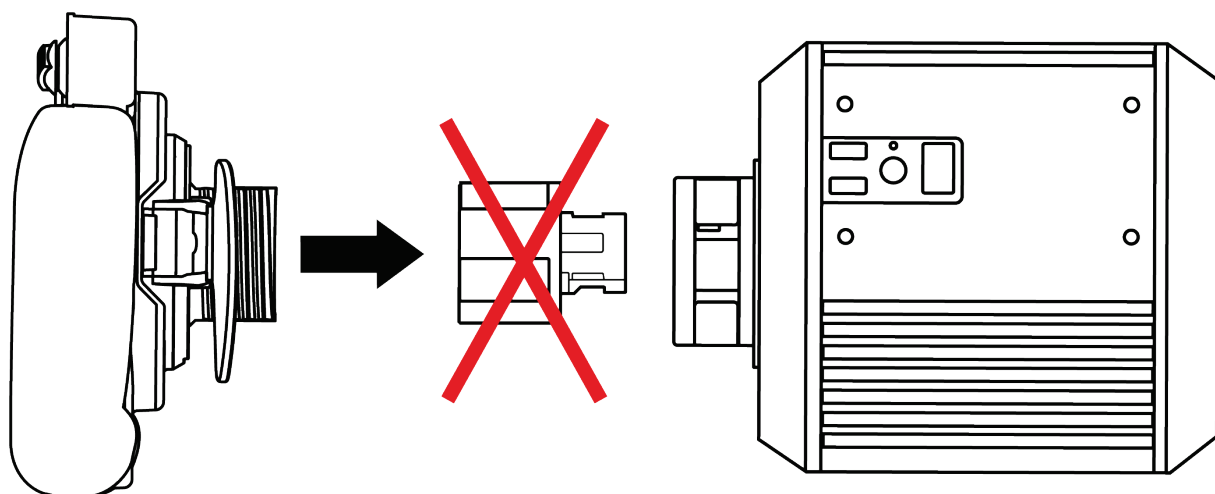
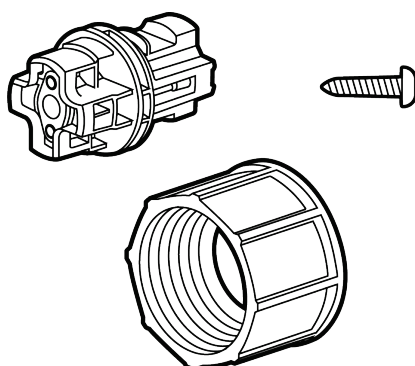

W przypadku podstawy T818 lub podstawy wyposażonej w złącze do podstawy z zatrzaskiem używaj wyłącznie **uchwyty szybkorozłącznego do podstawy z zatrzaskiem** dostarczonego z kierownicą **Ferrari 488 GT3 Wheel Add-On**.



5. Mapowanie

Mapowanie na komputerze PC

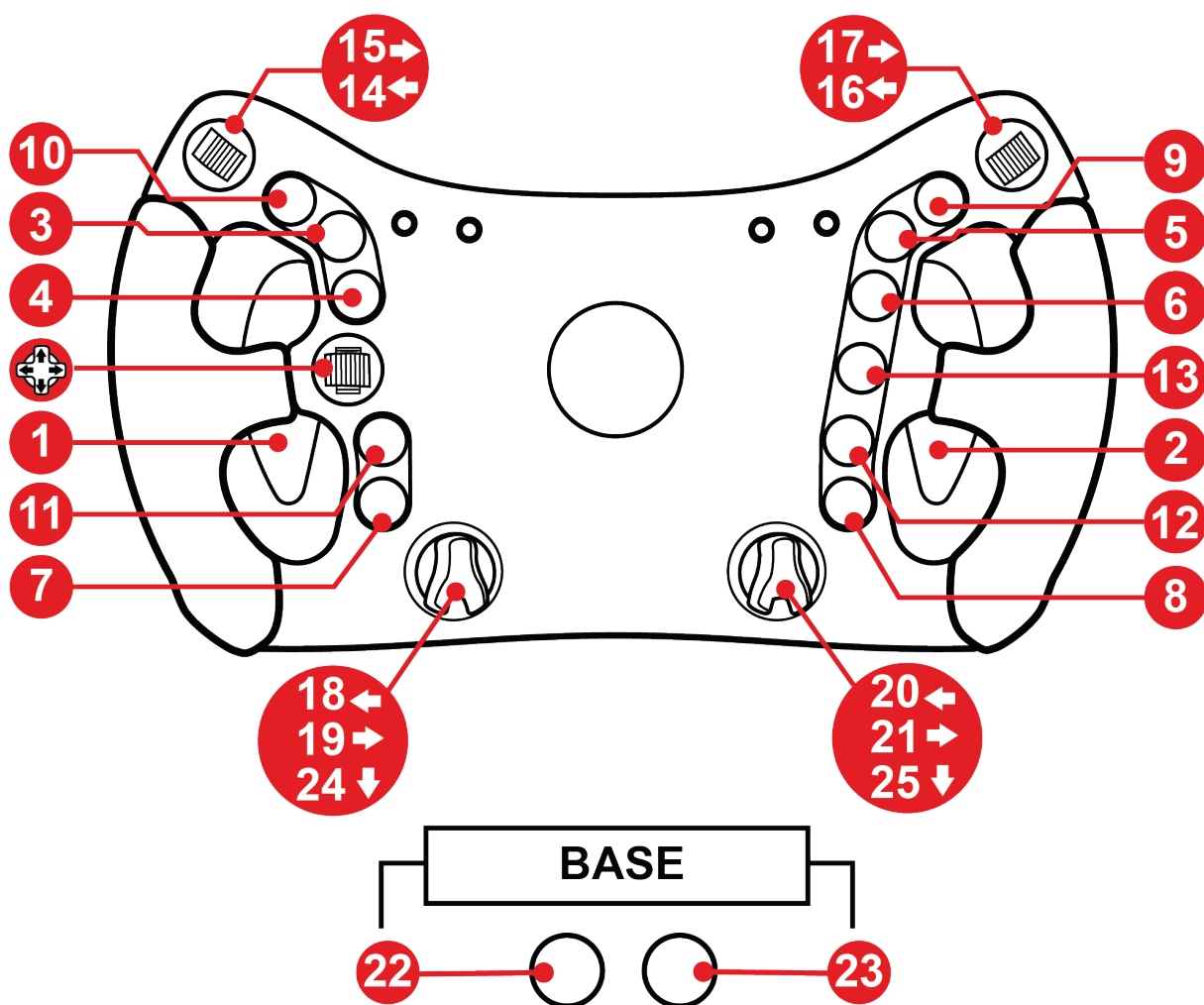



Mapowanie na konsoli PS4™/PS5™

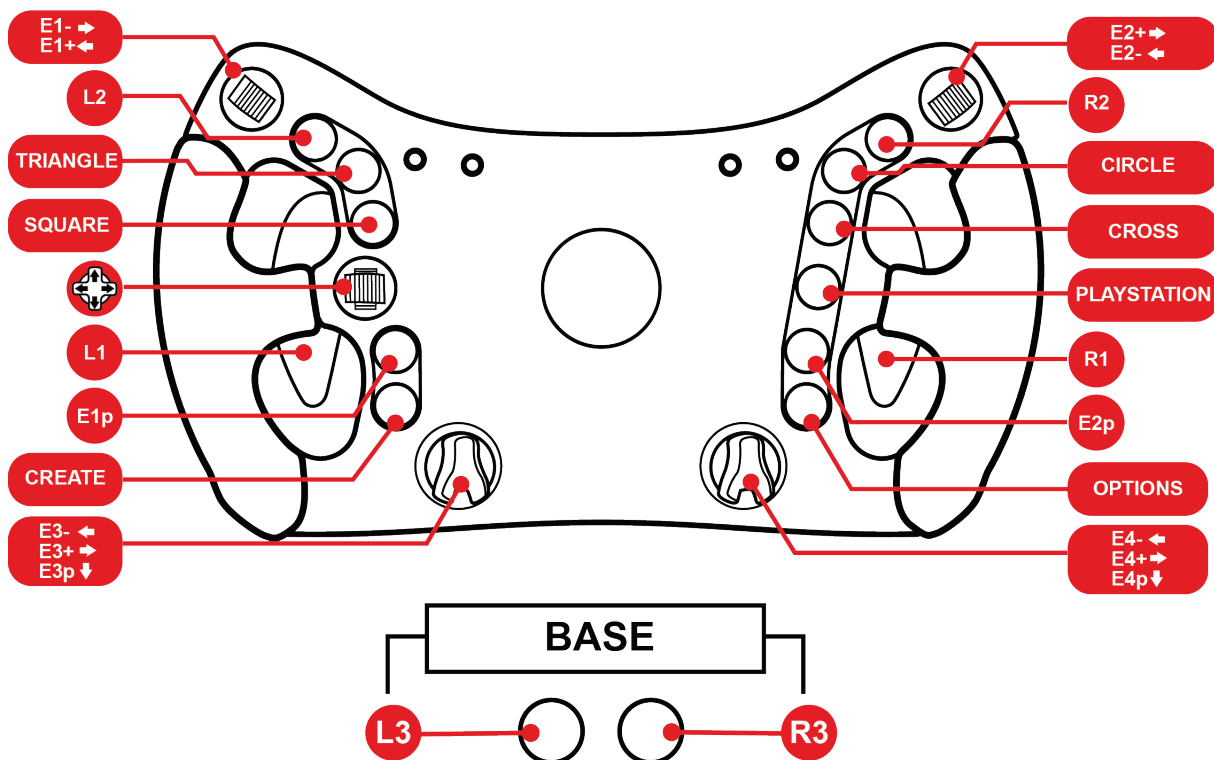



Mapowanie na konsoli Xbox Series/Xbox One

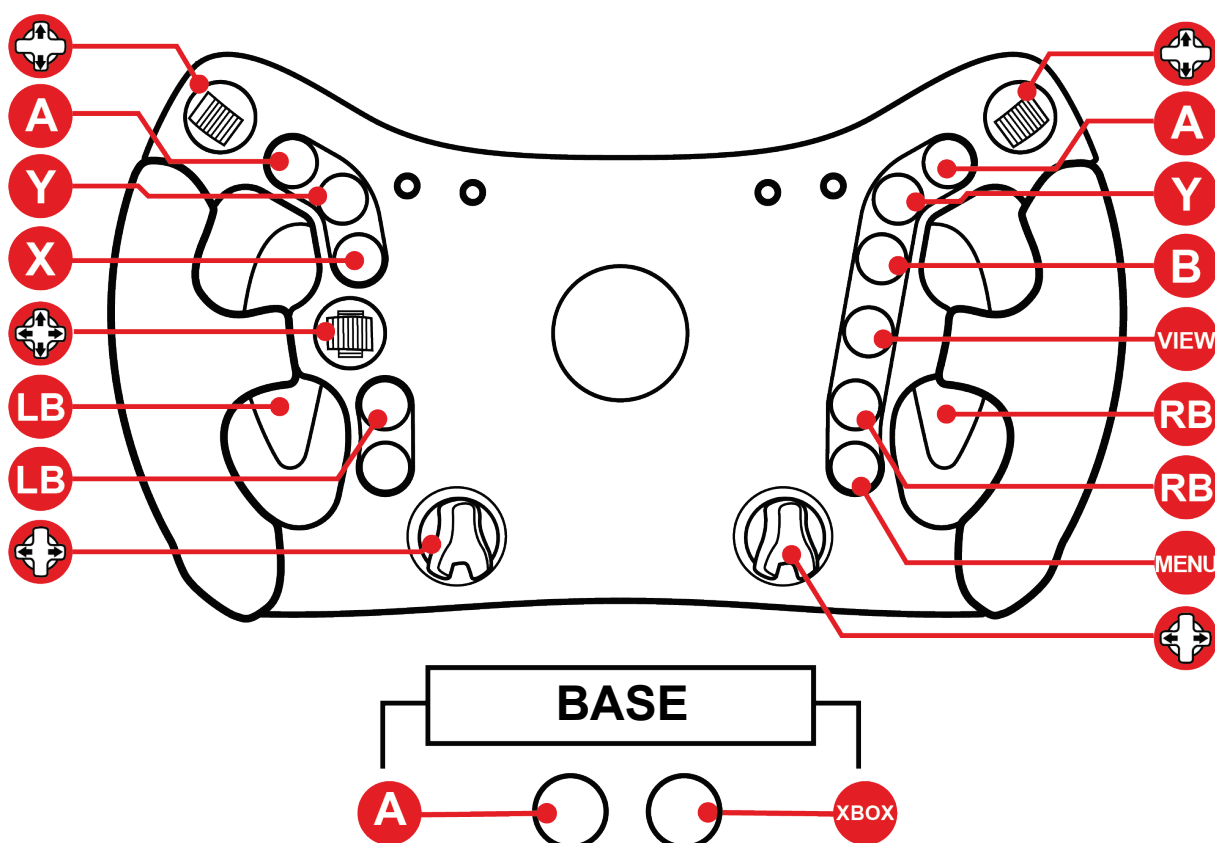

W przypadku konsol Xbox Series i Xbox One:

- Diody kierownicy Ferrari 488 GT3 Wheel Add-On nie działają z powodu ograniczeń protokołu konsoli.
- Niektóre funkcje (kodery, liczba przycisków) są ograniczone przez protokół konsoli.



6. Działanie diod

Kierownica **Ferrari 488 GT3 Wheel Add-On** przekazuje dane dotyczące wyścigu za pomocą diod flagi, pit-stopu i prędkości obrotowej silnika (RPM).

Wyświetlane dane można dostosować (modyfikując natężenie i kolor diod prędkości obrotowej) w zależności od trybu (GT3 lub Formula).

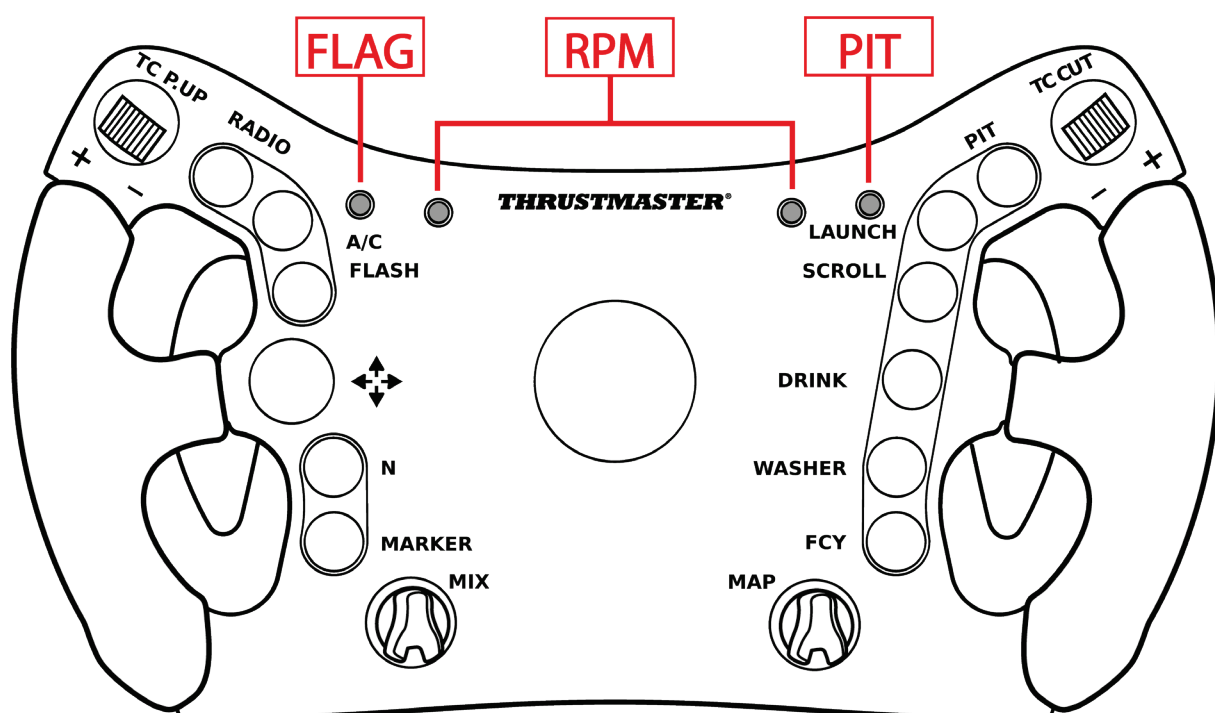

Diody działają na komputerze PC i konsolach PS4™/PS5™.

W przypadku konsol Xbox Series i Xbox One diody nie działają z powodu ograniczeń protokołu konsoli.



Jak wejść/wyjść z menu diod

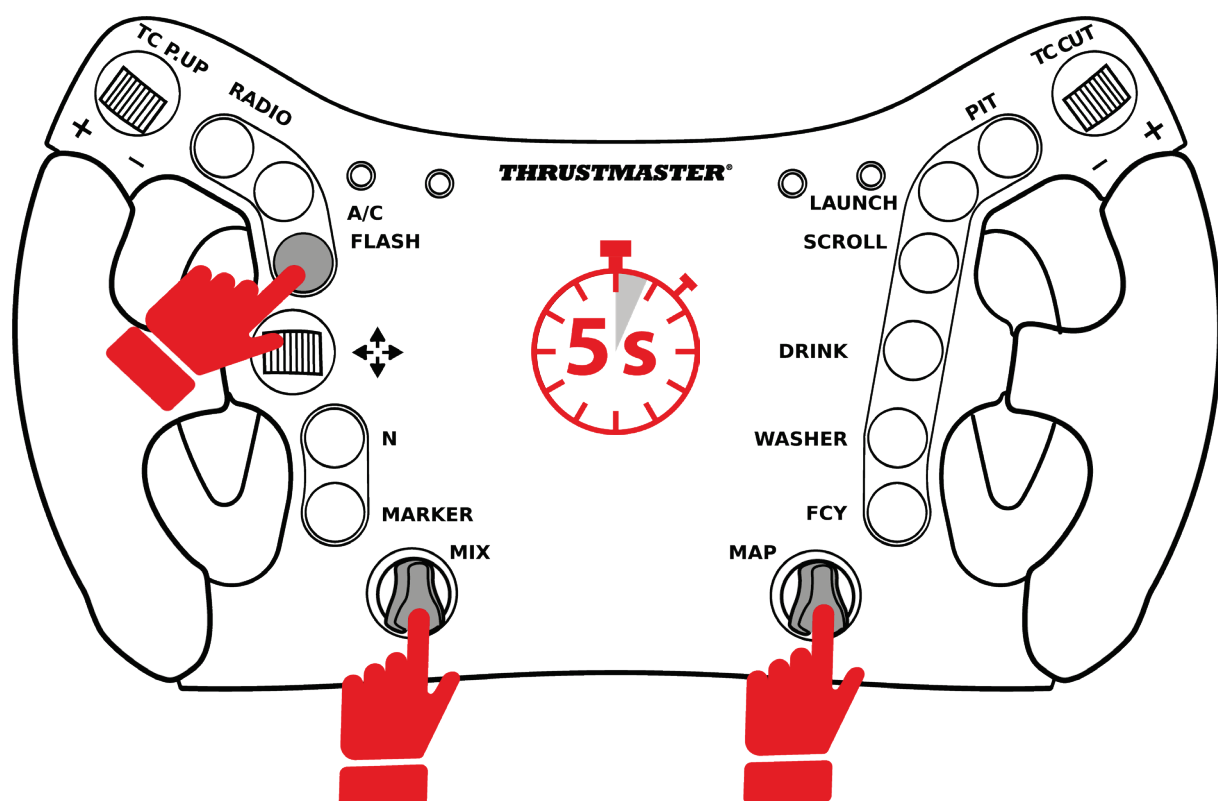

– Aby wejść do menu diod, naciśnij jednocześnie przycisk **FLASH** i oba **pokrętła kodujące przez 5 sekund**, a następnie je zwolnij.

– Aby wyjść z menu diod, naciśnij jednocześnie przycisk **FLASH** i oba **pokrętła kodujące**, a następnie je zwolnij.

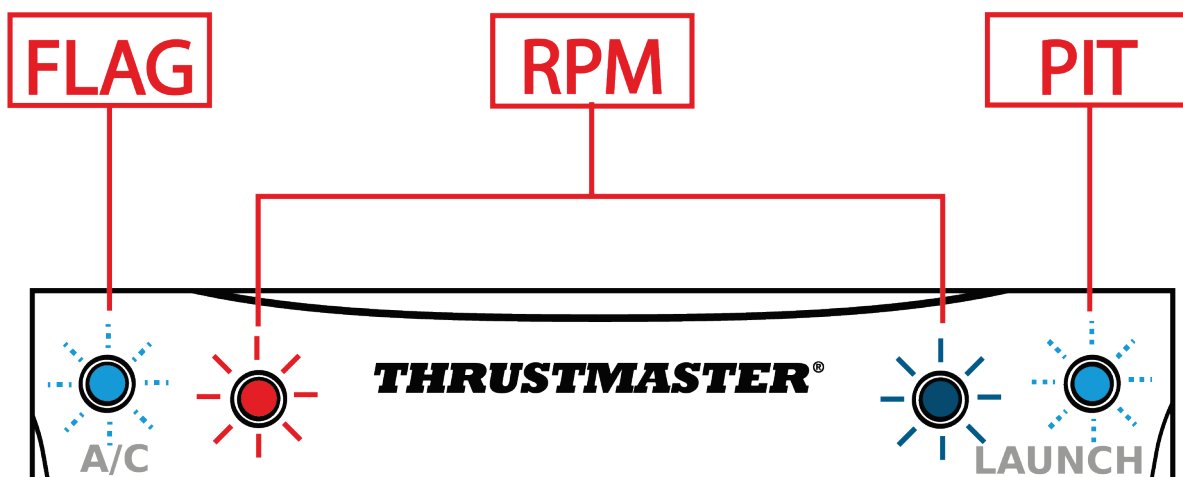

Wejście do menu diod: diody FLAG i PIT oraz jedna z diod prędkości obrotowej (czerwona po lewej stronie lub niebieska po prawej stronie) zaczynają świecić.



Wyjście z menu diod: wszystkie cztery diody gasną.



Jak dostosować natężenie diod

- Wejdź do menu diod, naciskając jednocześnie przycisk **FLASH** i oba **pokrętła kodujące** przez 5 sekund, a następnie je zwalniając.
- Obróć **lewe pokrętło kodujące (MIX)** w lewo, aby zmniejszyć natężenie, lub w prawo, aby je zwiększyć.

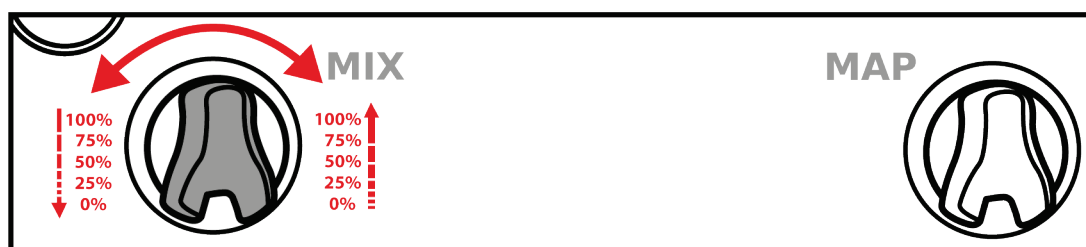

- Wyjdź z menu diod, naciskając jednocześnie przycisk **FLASH** i oba **pokrętła kodujące**, a następnie je zwalniając.



Jak zmienić tryb diod: GT3 lub Formula

- Wejdź do menu diod, naciskając jednocześnie przycisk **FLASH** i oba **pokręta kodujące przez 5 sekund**, a następnie je zwalniając.
- Obróć **prawe pokrętko kodujące (MAP)** w lewo, aby wybrać tryb GT3 (czerwona dioda), lub w prawo, aby wybrać tryb Formula (niebieska dioda).



Tryb GT3 (domyślny)



Tryb FORMULA

- Wyjdź z menu diod, naciskając jednocześnie przycisk **FLASH** i oba **pokręta kodujące**, a następnie je zwalniając.



7. Dostosowywanie łopatek zmiany biegów

Łopatki zmiany biegów dostępne w kierownicy **Ferrari 488 GT3 Wheel Add-On** można regulować pod względem **odstępu** i **zakresu ruchu**.

Regulacja **odstępu** polega na zmodyfikowaniu rozstawu między łopatkami zmiany biegów w osi poziomej, co powoduje zmianę odległości między chwytami i łopatkami.

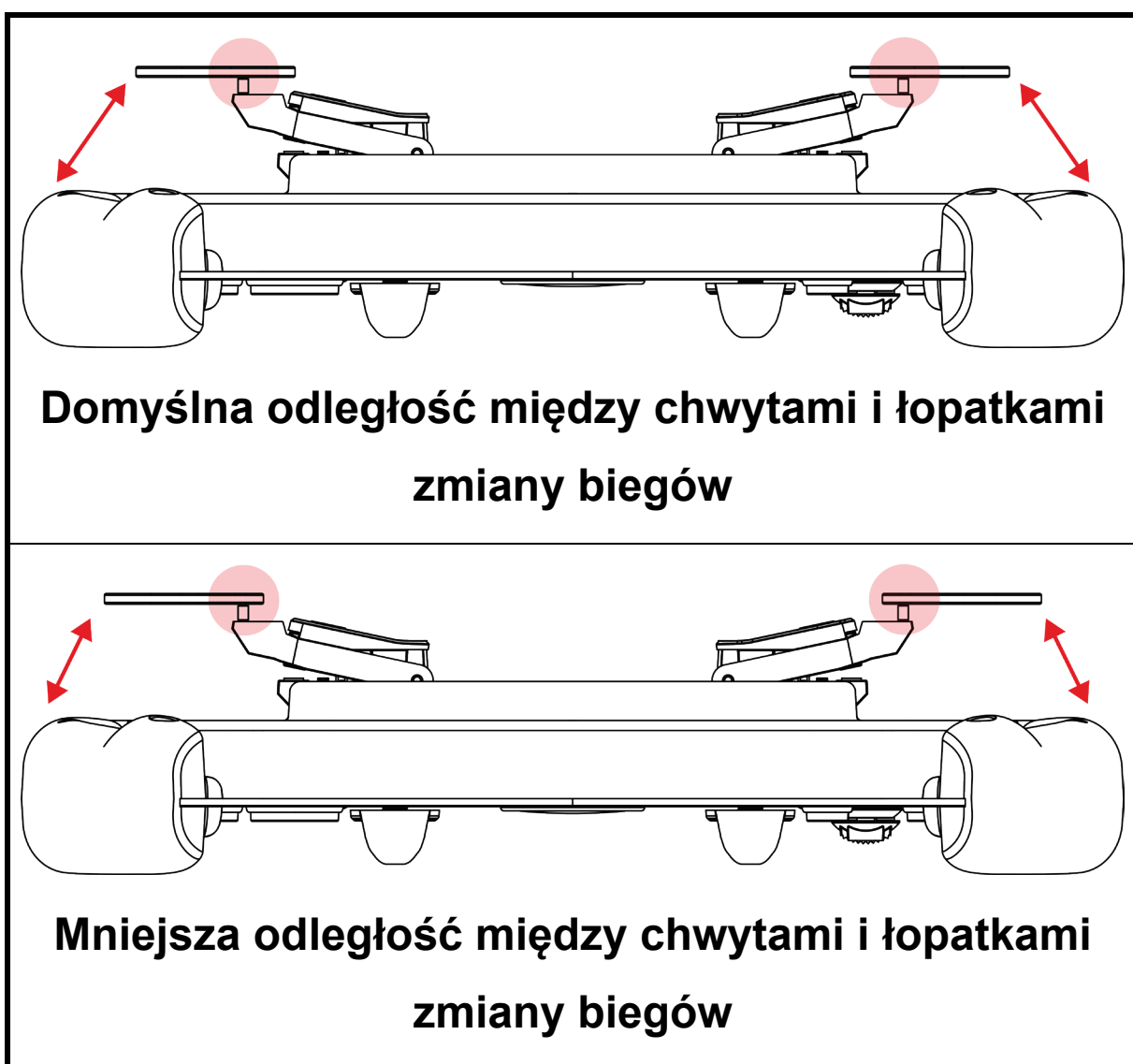



Modyfikacja **zakresu ruchu** przy użyciu elementów dystansowych powoduje zmianę odległości aktywacji łopatek zmiany biegów.

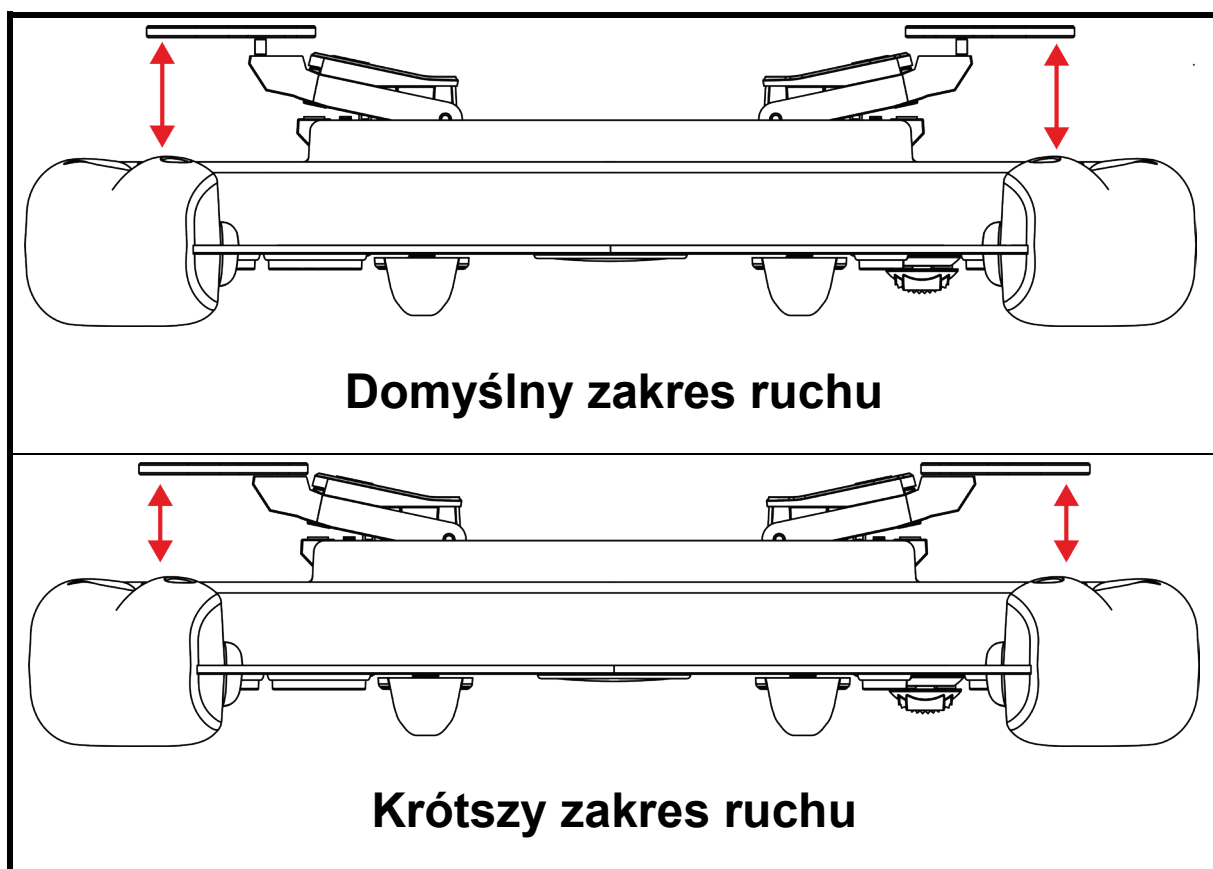

Ponadto za pomocą dostarczonego zestawu podkładek można dostosować **czułość magnetyczną** i **poziom dźwięku** wytwarzanego przez łopatek zmiany biegów.

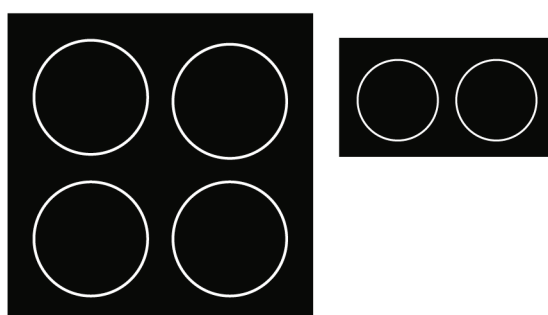



Jak dostosować odstęp łopatek zmiany biegów

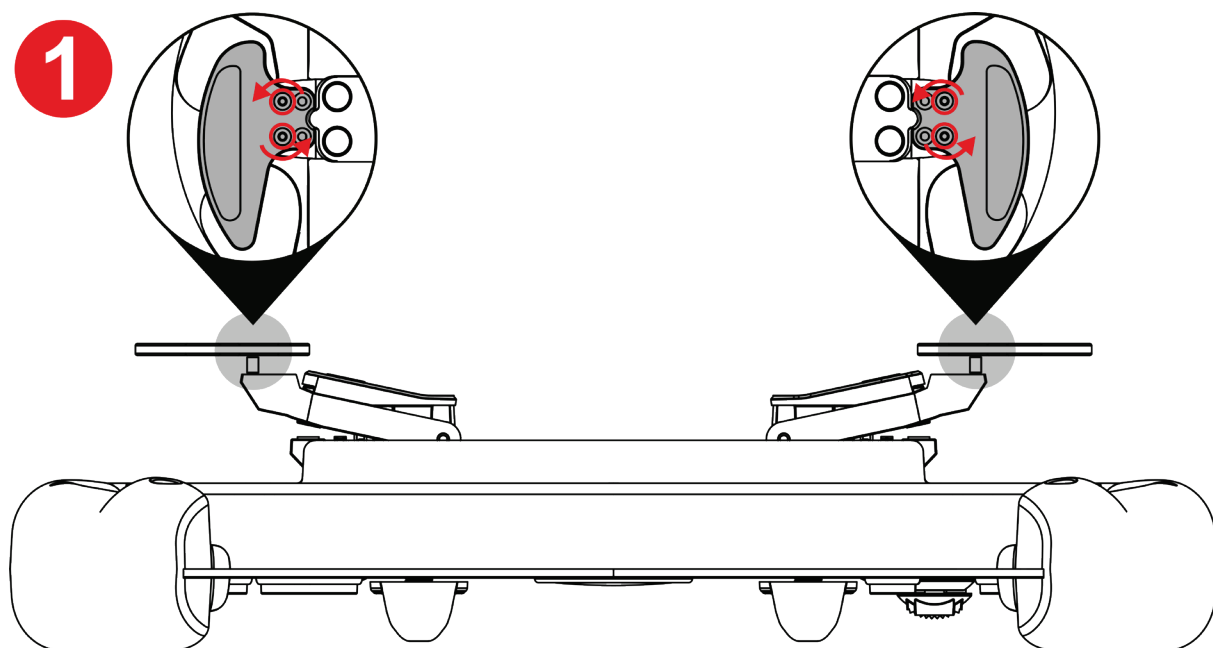

1 Odkręć cztery śruby łopatek zmiany biegów przy użyciu dostarczonego klucza Torx.

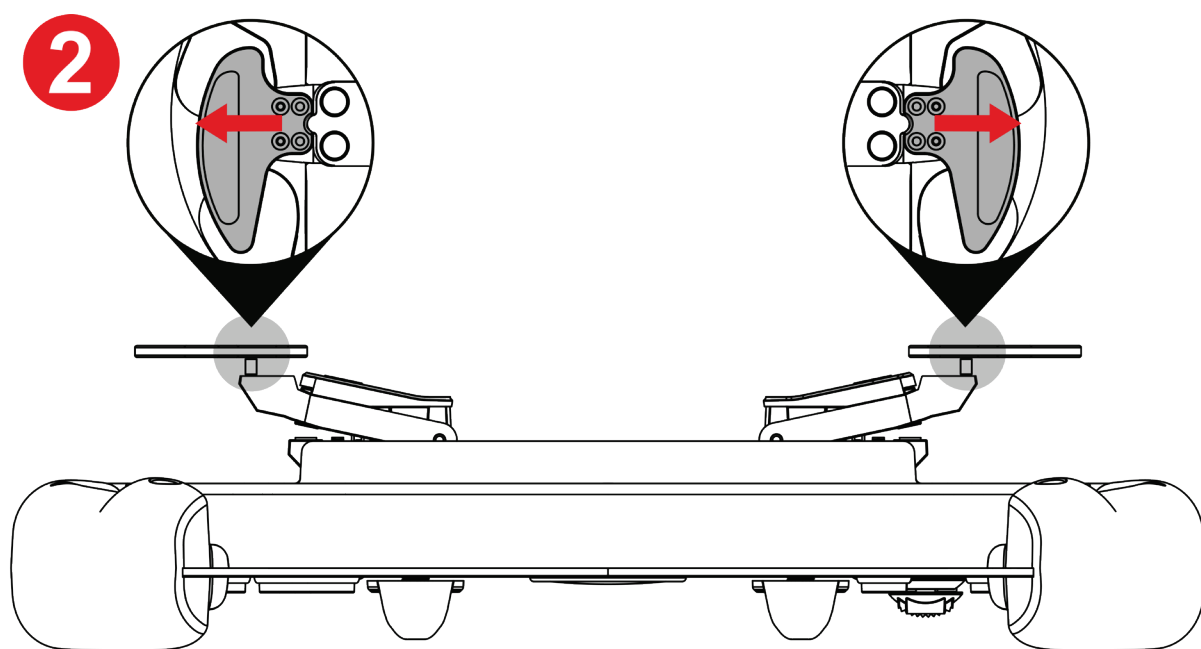

2 Przesuń łopatki zmiany biegów w kierunku na zewnątrz, dopasowując je do otworów.

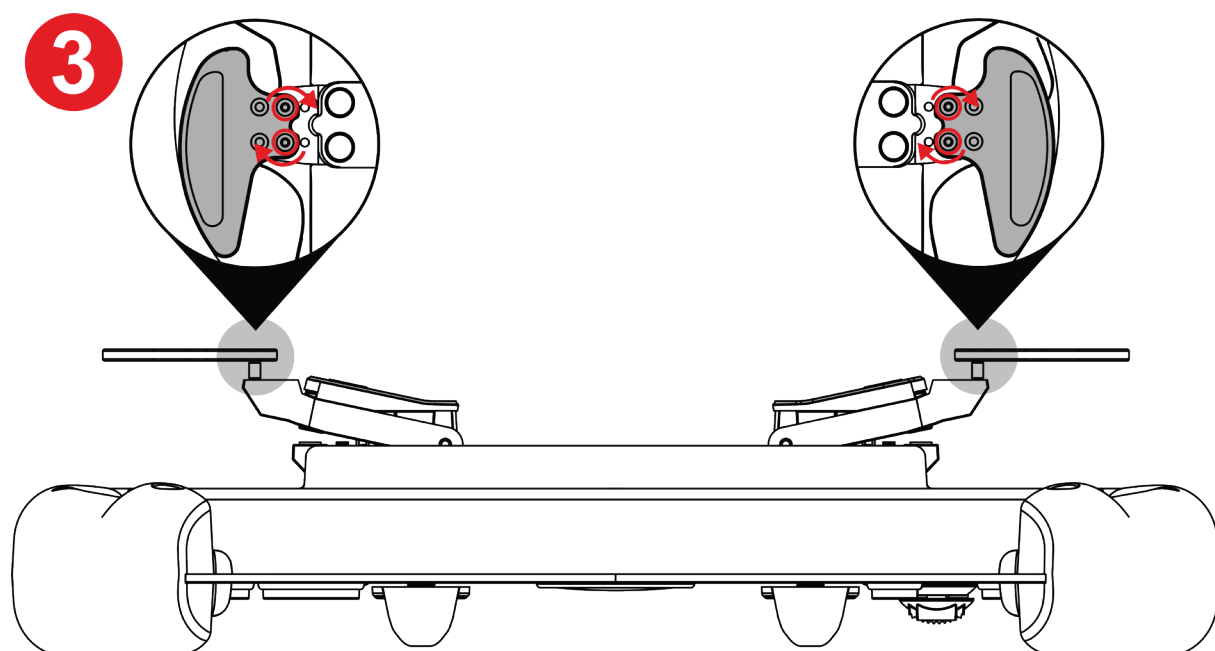

3 Przykręć cztery śruby łopatek zmiany biegów przy użyciu dostarczonego klucza Torx.



Jak dostosować zakres ruchu łopatek zmiany biegów

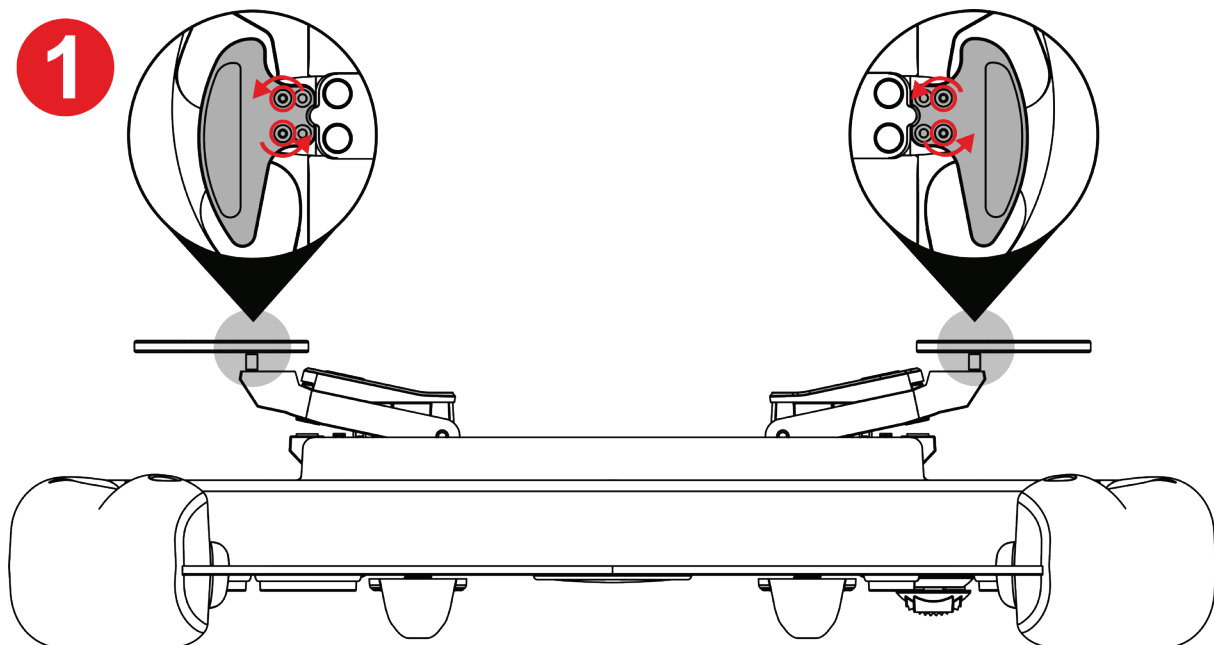

1 Odkręć cztery śruby łopatek zmiany biegów przy użyciu dostarczonego klucza Torx.

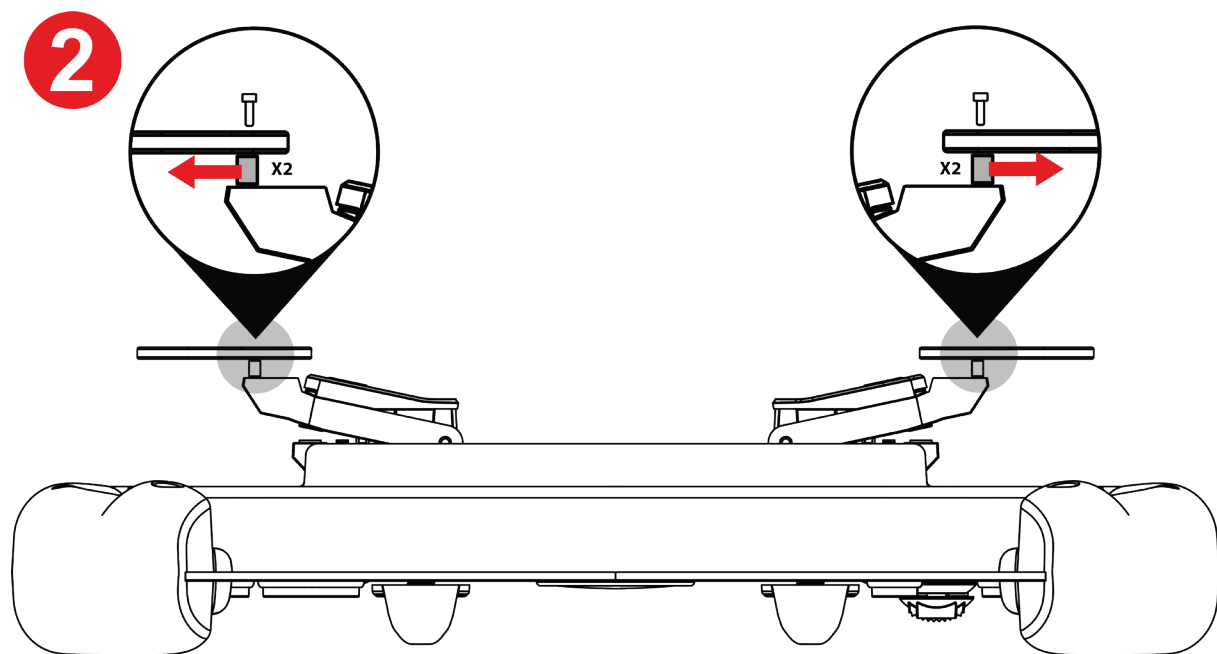

2 Zdejmij elementy dystansowe.

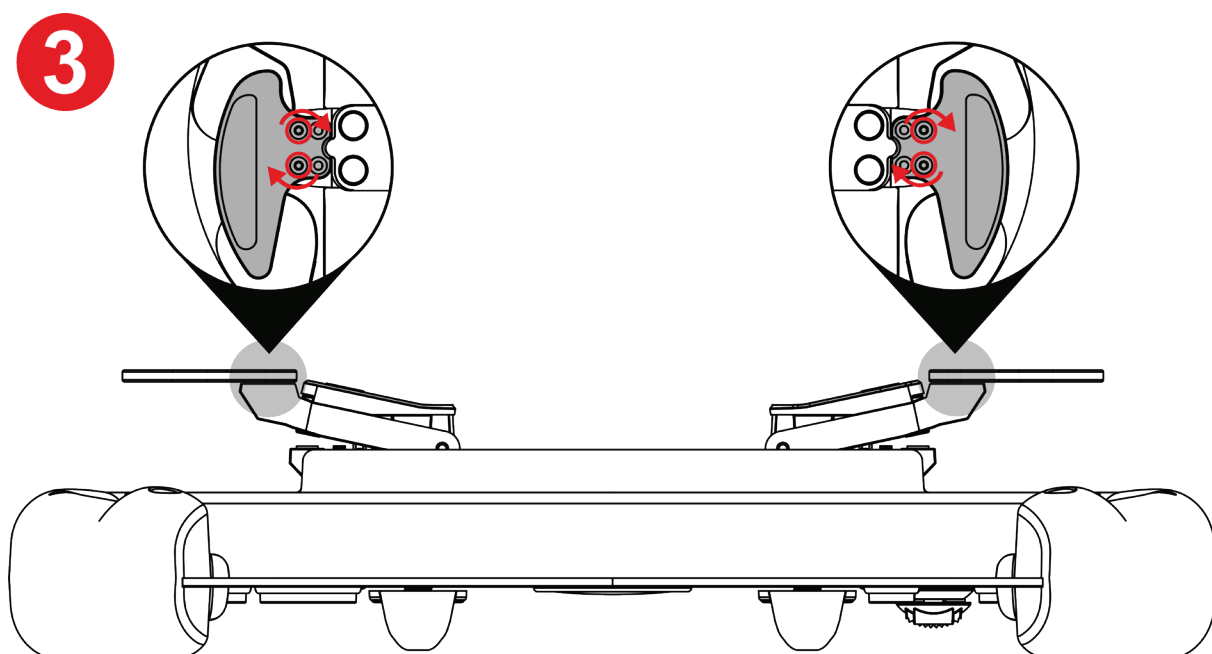

3 Przykręć cztery śruby łopatek zmiany biegów przy użyciu dostarczonego klucza Torx.



Jak dostosować czułość magnetyczną i poziom dźwięku łopatek zmiany biegów

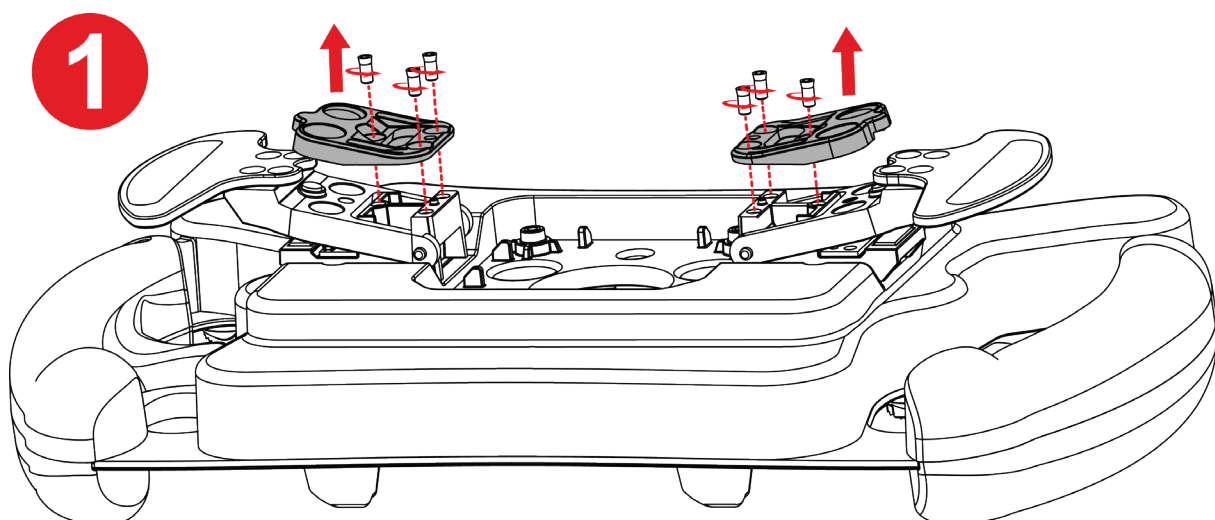

1 Zdemontuj ograniczniki magnetyczne, odkręcając ich sześć śrub przy użyciu dostarczonego klucza Torx.

2

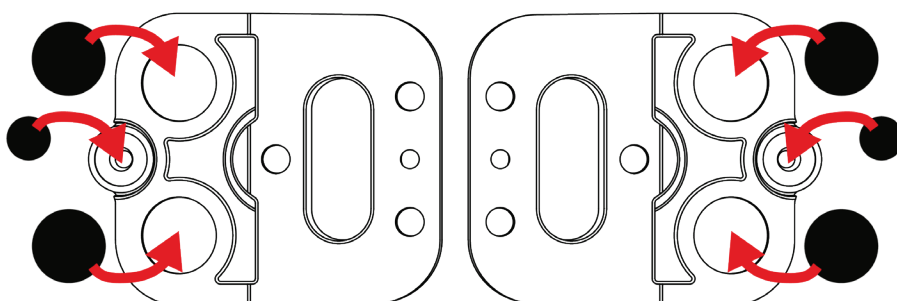
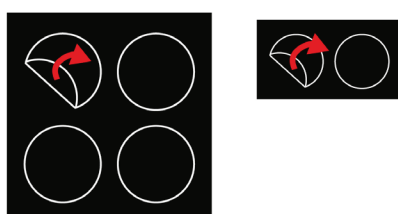

2 Odklej dostarczone podkładki i przyklej je w odpowiednich miejscach pod ogranicznikami magnetycznymi.



Możliwe konfiguracje i skutki ich zastosowania zawiera **Tabela czułości magnetycznej i tłumienia dźwięku łopatek zmiany biegów.**





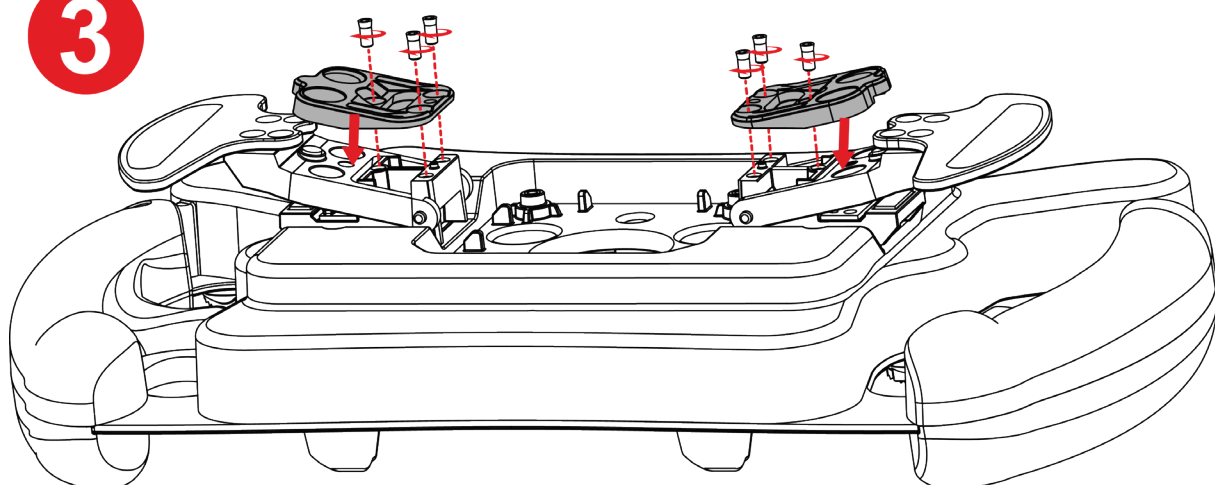

3

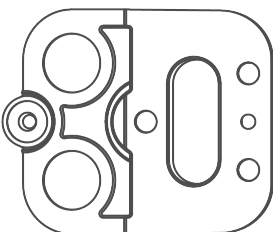
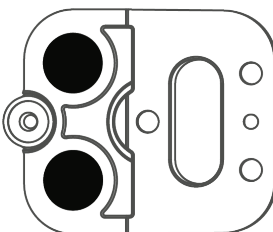
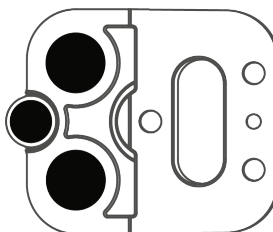

3 Ponownie zamontuj ograniczniki magnetyczne, przykręcając ich sześć śrub przy użyciu dostarczonego klucza Torx.

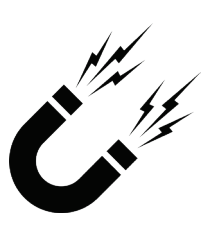
Tabela czułości magnetycznej i tłumienia dźwięku łopatek zmiany biegów

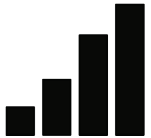
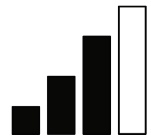
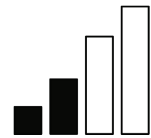
	 (domyślnie)		
Czułość magnetyczna			
Dźwięk			



8. Często zadawane pytania i pomoc techniczna

Masz pytania dotyczące kierownicy Ferrari 488 GT3 Wheel Add-On lub napotykasz problemy techniczne? Jeśli tak, wejdź na stronę pomocy technicznej Thrustmaster:

<https://support.thrustmaster.com/product/ferrarif488gt3addon>.

Na tej stronie możesz też zaktualizować oprogramowanie sprzętowe kierownicy.



THRUSTMASTER®

FERRARI 488 GT3 WHEEL ADD-ON

PC (Windows 10/11)

PS4™ / PS5™

Xbox Series / Xbox One

ユーザーズマニュアル



本製品を取り付ける前、使用する前、およびメンテナンスする前に、このマニュアルに記載されている指示をよくお読みください。安全に関する注意事項を必ず守ってください。これらの指示に従わない場合、事故や破損の原因となります。このマニュアルは、後で参照できるように保管しておいてください。

目次

1.	パッケージ内容	5
2.	機能	6
3.	ステアリングコントローラーの使用に 関する情報	8
4.	クイックリリースホルダーの取り付け	13
	ラッチベース用クイックリリースホルダー の取り付け.....	14
	スクリューベース用クイックリリースホルダーの取 り付け.....	17
5.	マッピング	21
	PC 用マッピング.....	21
	PS4™/PS5™ 用マッピング.....	22
	Xbox Series/Xbox One 用マッピング	23
6.	LED 動作	24
	LED メニューへの入り方/閉じ方.....	25

LED 強度の調整方法..... 27

LED モードの変更方法: GT3 または

Formula..... 28

7. パドルシフターのカスタマイズ..... 29

パドルシフターの間隔を調整する方法..... 31

パドルシフターのリーチを調整する方法..... 33

パドルシフターの磁気感度とサウンドレベルの調整方法..... 35

8. FAQ とテクニカルサポート..... 37



FERRARI 488 GT3 WHEEL ADD-ON

Ferrari 488 GT3 Wheel Add-On で、GT レースの伝説に加わりましょう。このステアリングホイールはパフォーマンス重視のレーサー向けに設計され、すべての Thrustmaster ステアリングホイールベースと互換性があります。

このマニュアルは、Ferrari 488 GT3 Wheel Add-On を最適な条件で設置および使用するのに役立ちます。レースを始める前に、説明書と警告をよく読んでください。これらの情報は、製品の楽しさを最大限に引き出すために役立ちます。



1. パッケージ内容

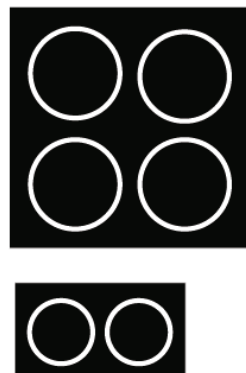
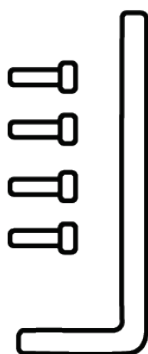
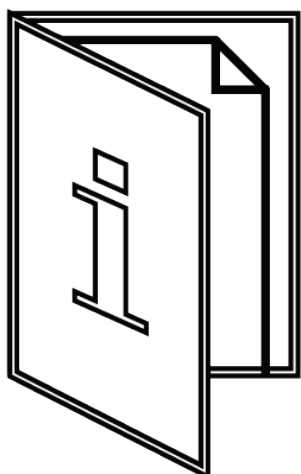
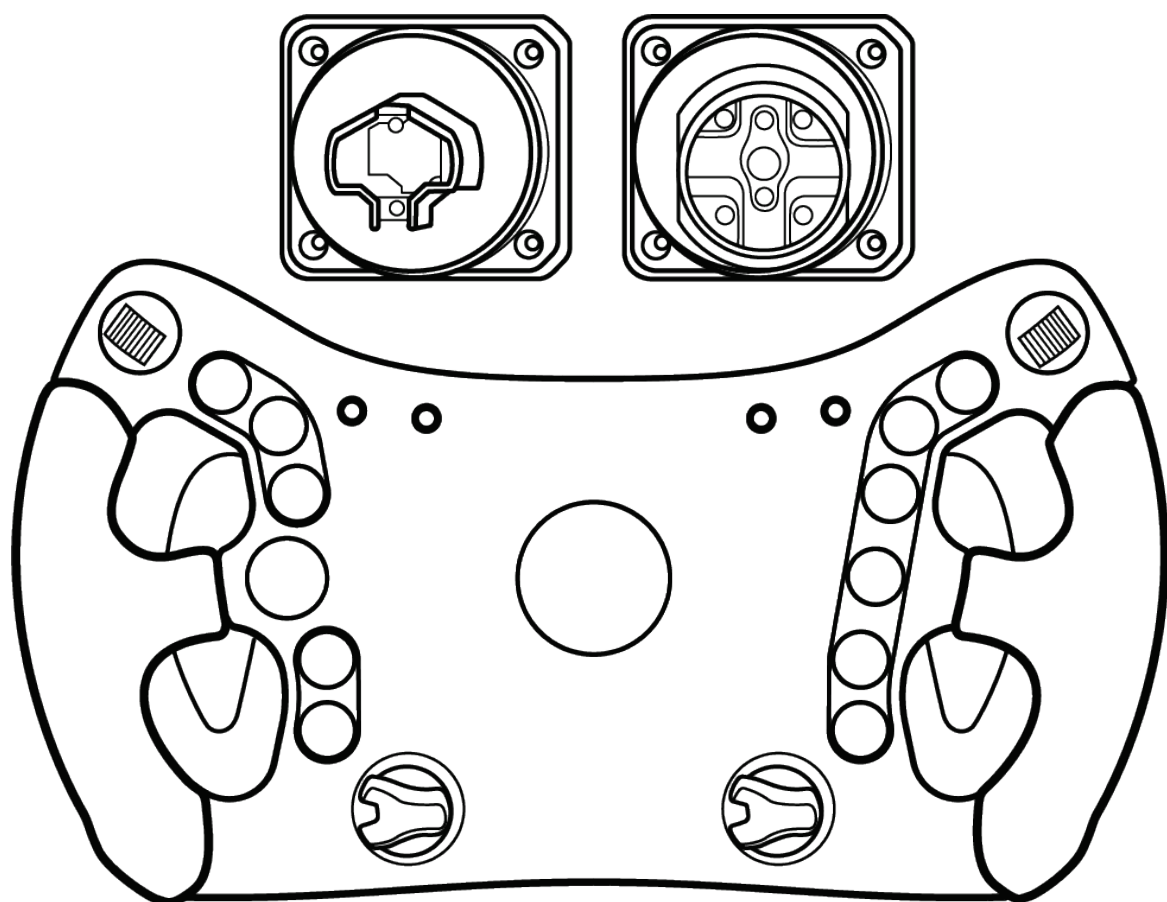



2. 機能

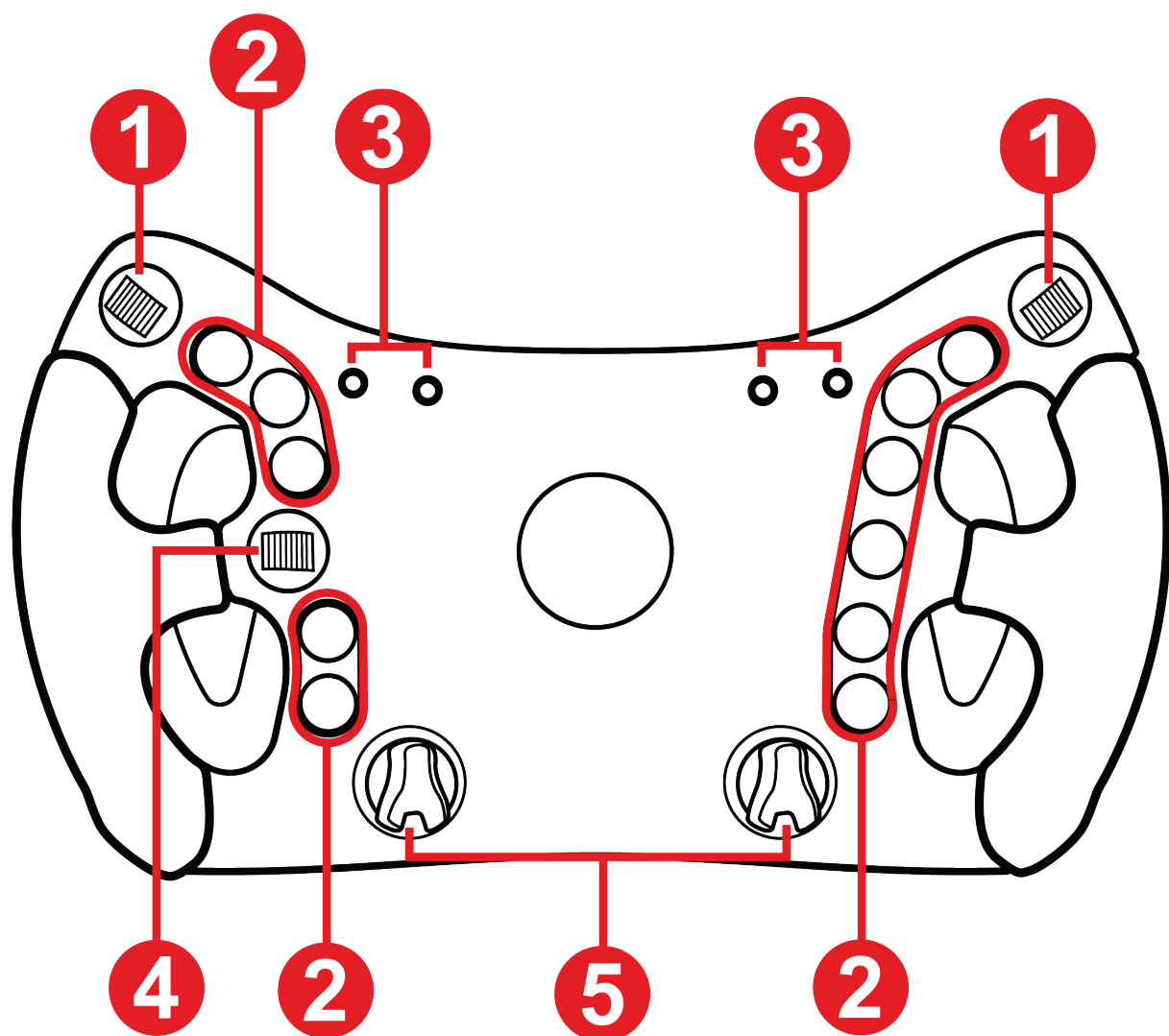

- ① サムエンコーダー
- ② アクションボタン 11 個
- ③ RPM LED とレースデータ (フラッグ、ピット)
- ④ 方向パッド
- ⑤ ロータリーエンコーダー

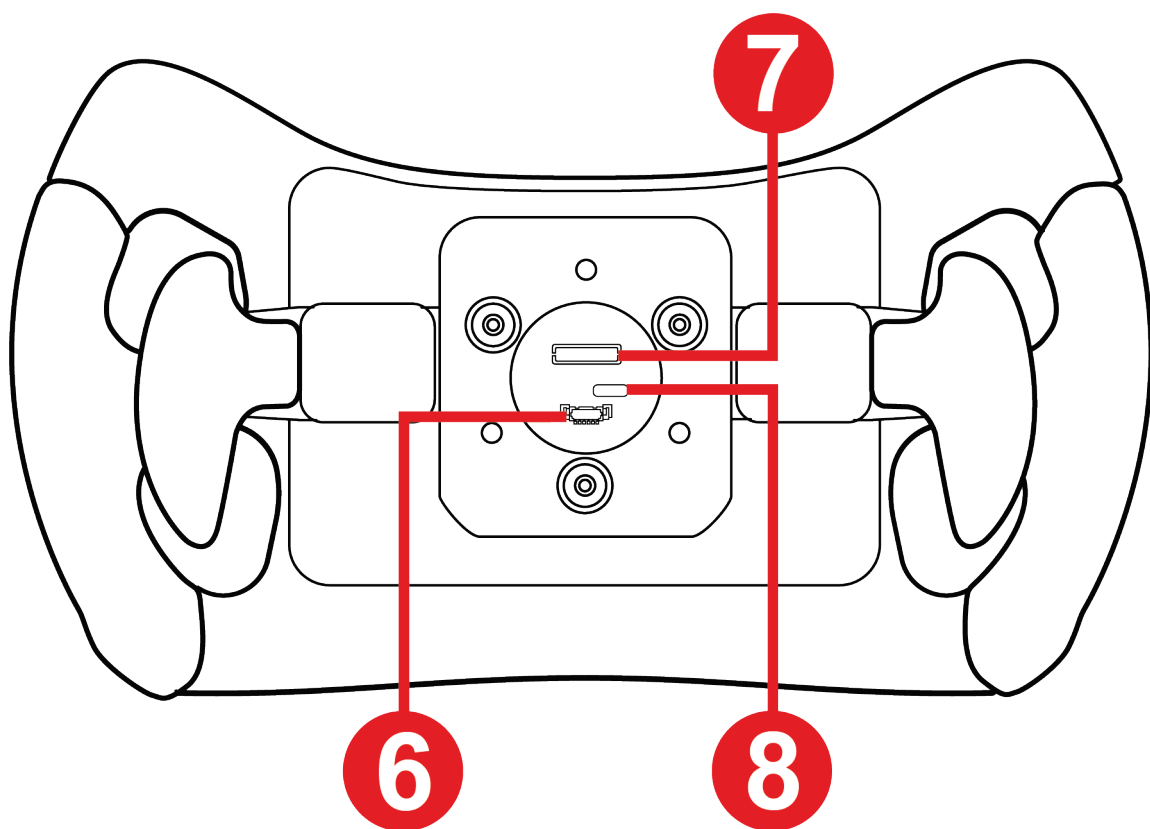

- ⑥ スクリューベース用クイックリリースホルダー用接続ポート
- ⑦ ラッチベース用クイックリリースホルダー用接続ポート
- ⑧ USB-C ポート (ファームウェアのアップデートが必要な場合 - ケーブルは付属しません)

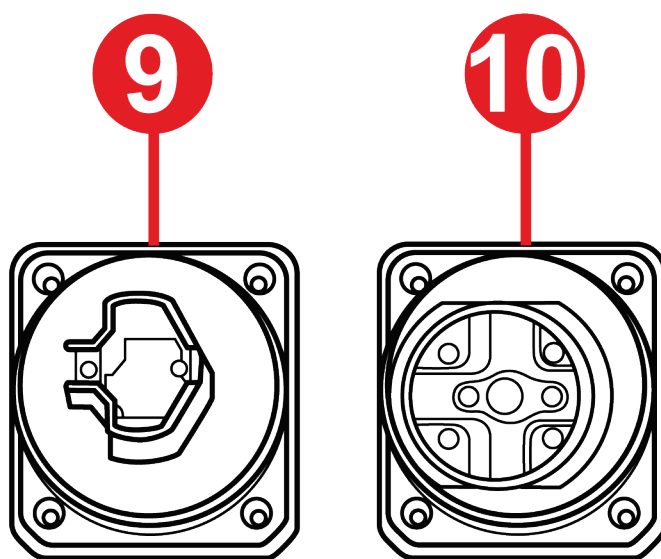

- ⑨ ラッチベース用クイックリリースホルダー
- ⑩ スクリューベース用クイックリリースホルダー



3. ステアリングコントローラーの使用に関する情報



ドキュメント

本製品をお使いになる前に、このドキュメントをもう一度よくお読みになり、後で参照できるように保管しておいてください。



感電

- 本製品は湿気・ホコリの多い場所や、直射日光のあたる場所で保管しないでください。
- コネクターやケーブルを、ねじったり引っ張ったりしないでください。
- 接続手順に正しくしたがってください。
- 本製品やコネクターをぬらさないでください。
- 本製品をショートさせないでください。
- 分解（本マニュアルに記載されている調節などは除く）や改造は絶対にしないでください。本製品を火の中に投棄したり、高温にさらしたりしないでください。
- 本体を分解しないでください。内部にはユーザーが保守可能な部品はありません。修理はメーカー、指定修理業者、あるいは資格を有する技術者までご依頼ください。



プレイエリアの安全確保

- プレイエリア内には、ユーザーの操作を妨害する可能性がある物や、第三者による不適切な動作や干渉を引き起こすような物（コーヒーカップ、電話、鍵など）を置かないでください。
- 電源ケーブルをカーペットやラグ、毛布、カバーなどで覆ったり、人が歩く場所に置いたりしないでください。



フォースフィードバック、および繰り返しの動きによる負傷 の可能性

フォースフィードバック対応ステアリングコントローラーの使用は、筋肉や関節の痛みなどの症状を引き起こす恐れがあります。そのようなリスクを回避するため、以下をお守りください:

- 事前にウォーミングアップをし、長時間の練習は避けてください。
- 1 時間の練習ごとに 10~15 分の休憩をとるようにしてください。
- 手、手首、腕、足、脚を始めとする身体の部位に疲れや痛みを感じたときは、ボタンを押してフォースフィードバックをオフにしてベースの電源を切り、練習を再開する前に数時間の休憩をとるようにしてください。
- 休憩後に練習を再開しても、上記の症状や痛みがとれない場合は、練習を中止して医師に相談してください。
- フォースフィードバックは、自分のスキルや体調に配慮して、高すぎる値に設定しないでください。
- 16 歳未満の方の手の届かないところに置いてください。
- ステアリングホイールとベースが、マニュアルの指示通りに正しく固定されていることを確認してください。



予期せぬ強力かつ急速な回転の危険性: ステアリングホイールリムの開口部や、ステアリングホイールの回転軌道の部分に手や腕を絶対に入れないでください。

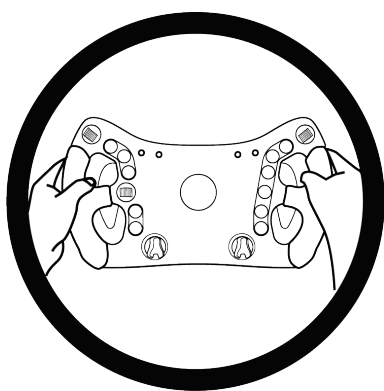

製品使用時は常に、ステアリングホイールの正しい位置に両手を置いて使用してください。ステアリングホイールから両手を完全に離さないでください。



本製品の対象年齢は 16 歳以上です。



4. クイックリリースホルダーの取り付け

Ferrari 488 GT3 Wheel Add-On には、Thrustmaster ベースのフォーマットに対応した 2 つのクイックリリースホルダーが付属しています。

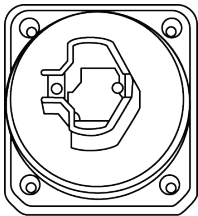
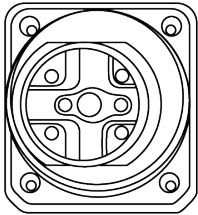
システム	互換性
 ラッチベース用クイックリリースホルダー	T818、T818 Ferrari SF1000 Simulator、および今後リリースされる Thrustmaster ベース。
 スクリューベース用クイックリリースホルダー	T-GT / T-GT II Servo Base、T300 RS Servo Base、TS PC Racer、TS-XW、TX Racing Wheel Servo Base、TS-XW Servo Base。



毎回使用する前に、このマニュアルの指示に従って、Ferrari 488 GT3 Wheel Add-On がベースに正しく取り付けられていることを確認してください。



ラッチベース用クイックリリースホルダーの取り付け

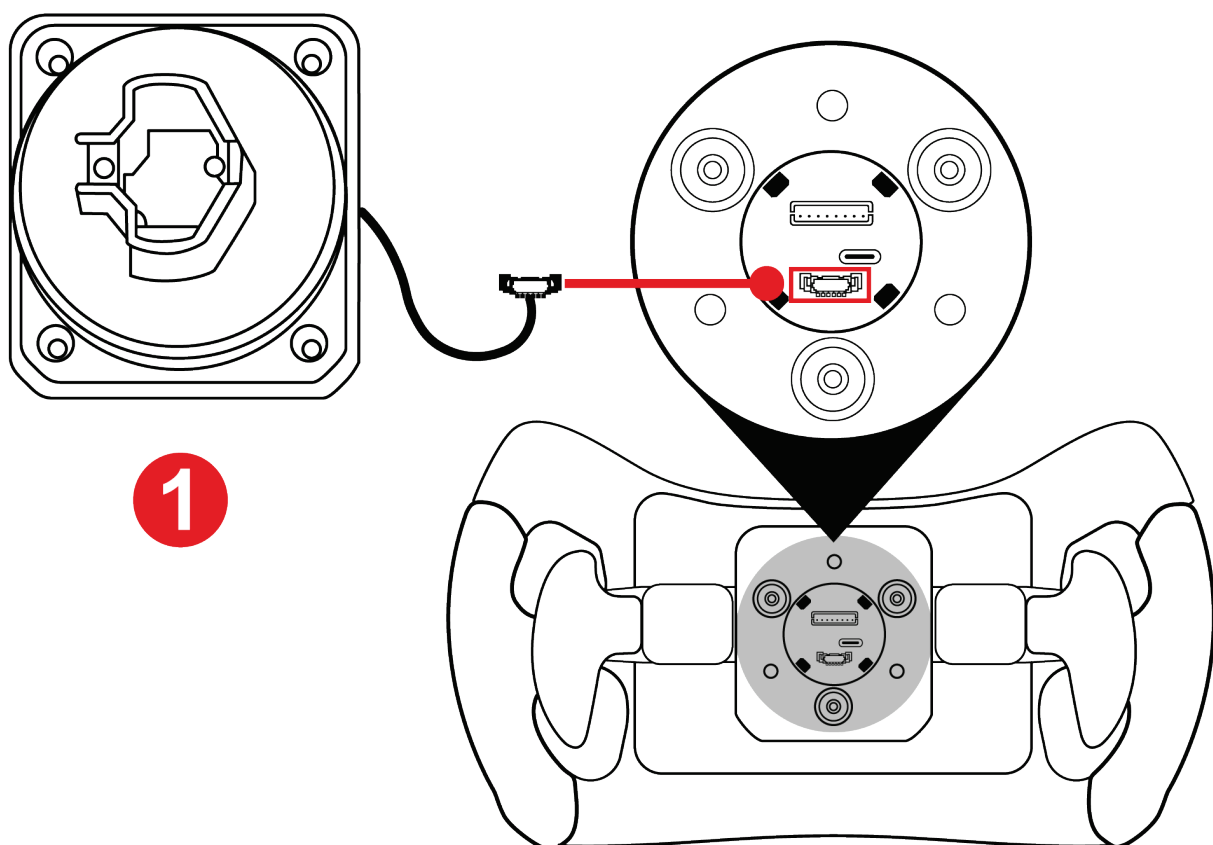

- ① クイックリリースホルダーのコネクターを、ステアリングコントローラー背面の対応するポートに差し込みます。



ケーブルの挟み込みを防ぐため、ホルダーをねじ込む前にケーブルを筐体内に収納してください。

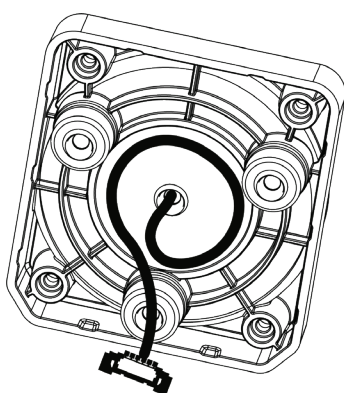

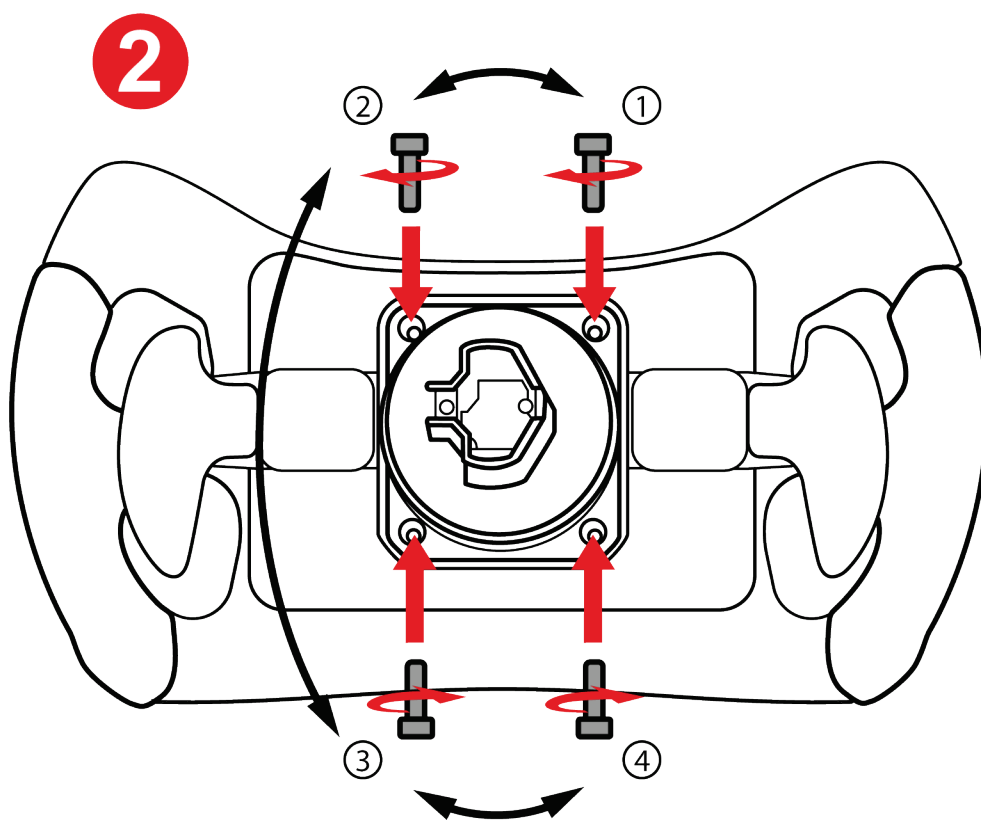

② クイックリリースホルダーを挿入し、付属のトルクスレンチで締めます。



ホルダーを取り付ける際は、ネジを締めすぎないようにしてください。

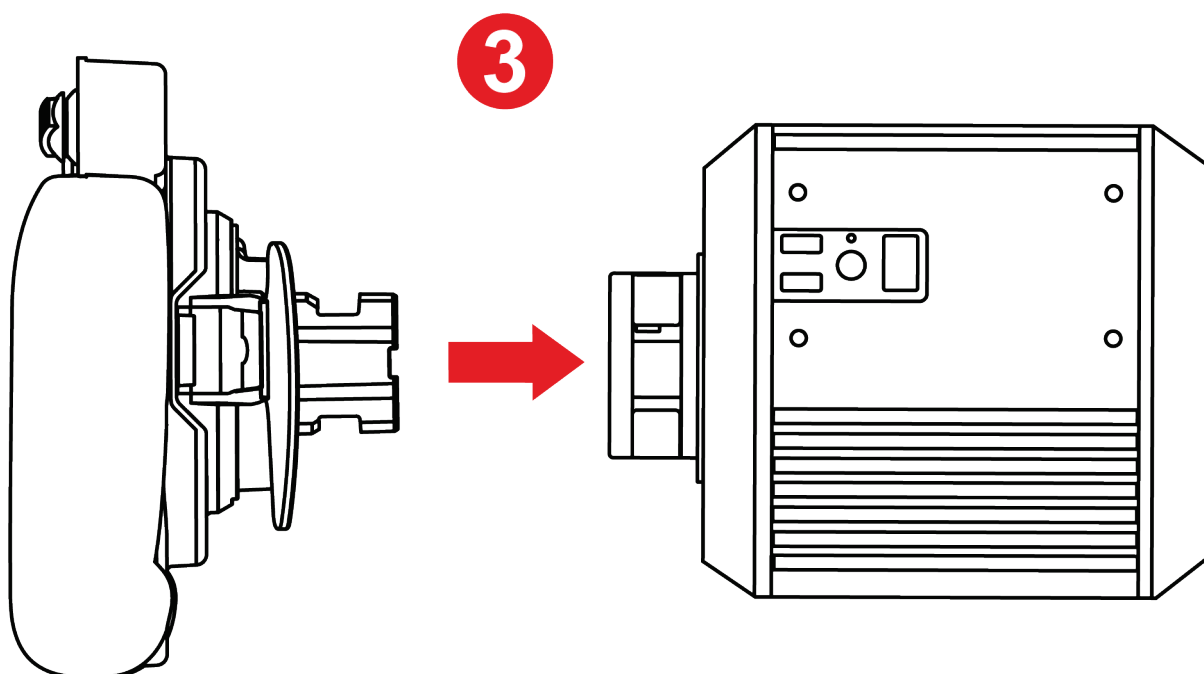

③ ステアリングホイールをベースに取り付けます。



ベースのユーザーズマニュアルに記載されているインストール手順に従ってください。



スクリューベース用クイックリリースホルダー の取り付け

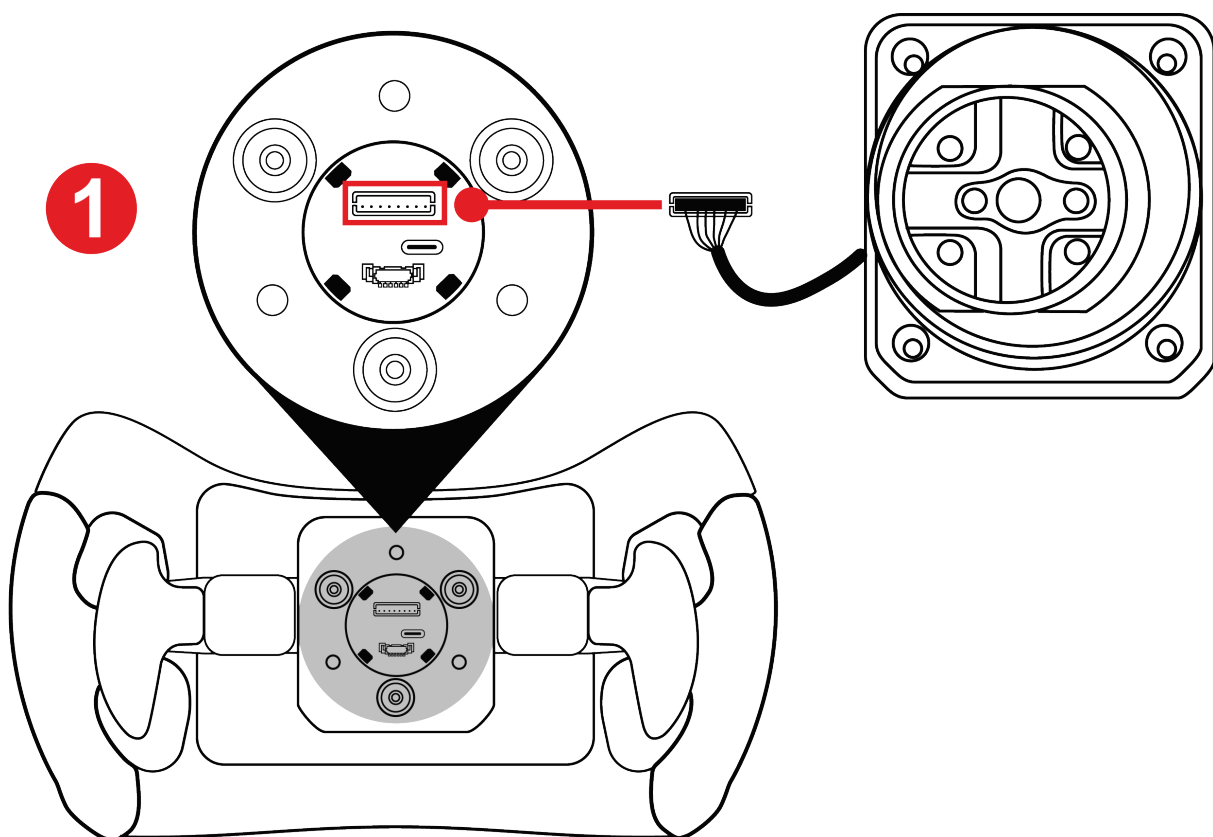

❶ クイックリリースホルダーのコンネクターを、ステアリングコントローラー背面の対応するポートに差し込みます。



ケーブルの挟み込みを防ぐため、ホルダーをねじ込む前にケーブルを筐体内に収納してください。

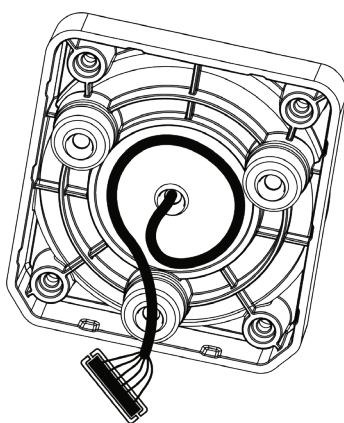

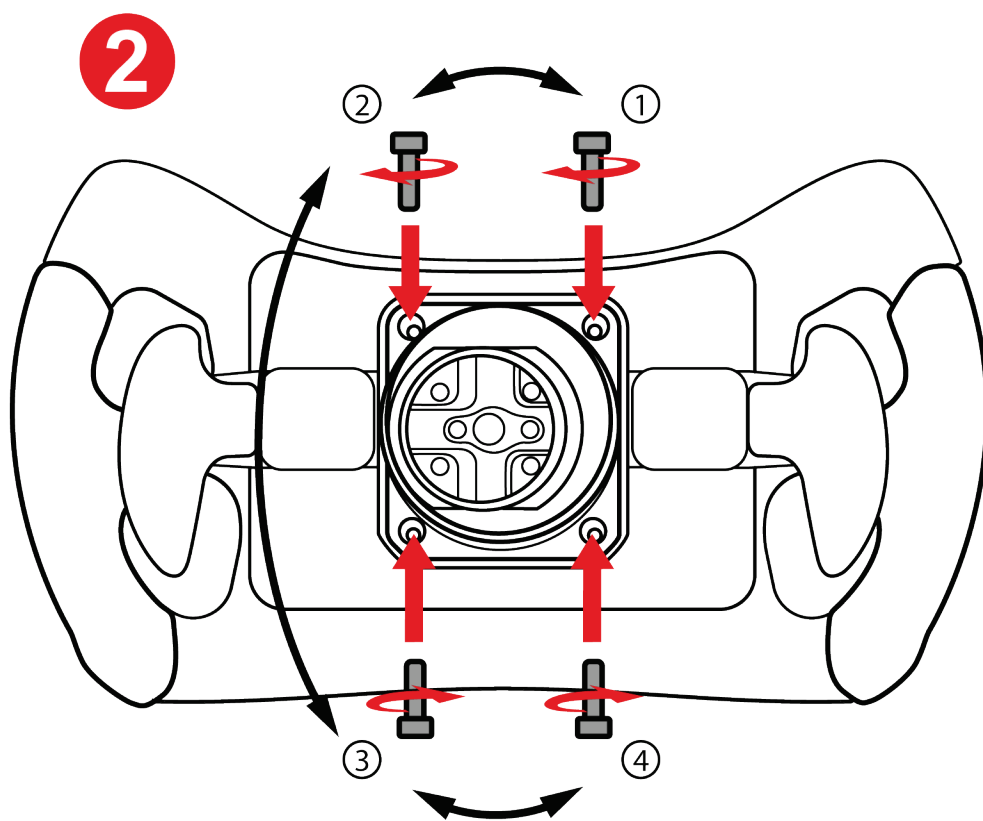

② クイックリリースホルダーを挿入し、付属のトルクスレンチで締めます。



ホルダーを取り付ける際は、ネジを締めすぎないようにしてください。

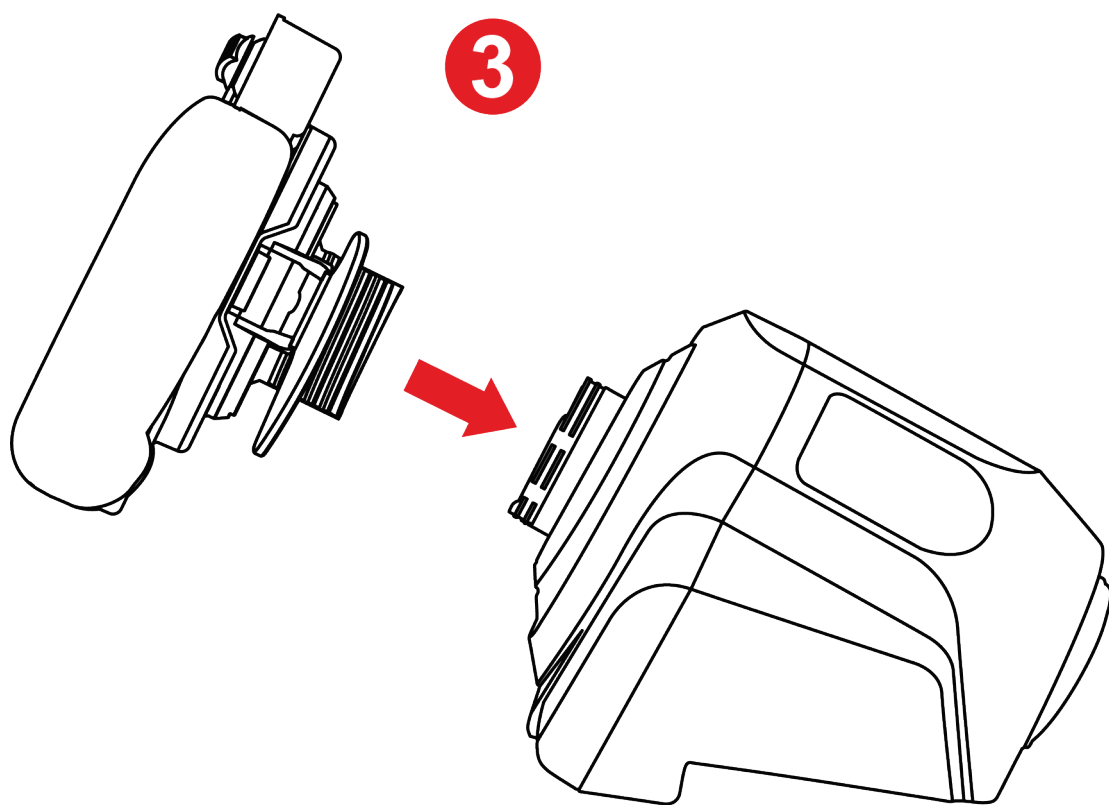

③ ステアリングホイールをベースに取り付けます。



ベースのユーザーズマニュアルに記載されているインストール手順に従ってください。



Quick Release Adapter (T818 ベース用、別売) を T818 ベースに使用する場合は、絶対にねじベース用クイックリリースホルダーには接続しないでください。

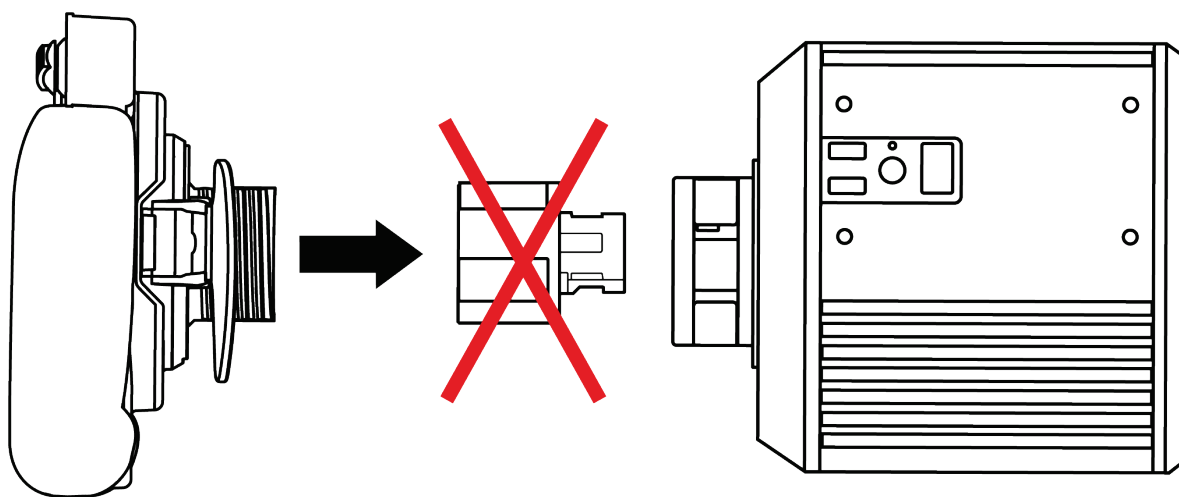
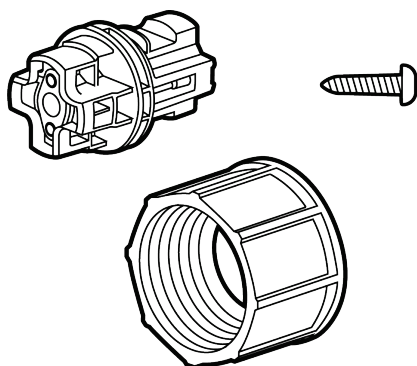

T818 ベースまたはラッチベース用コネクターを搭載したベースに使用する場合は、Ferrari 488 GT3 Wheel Add-On に付属のラッチベース用クイックリリースホルダーのみを使用してください。



5. マッピング

PC 用マッピング

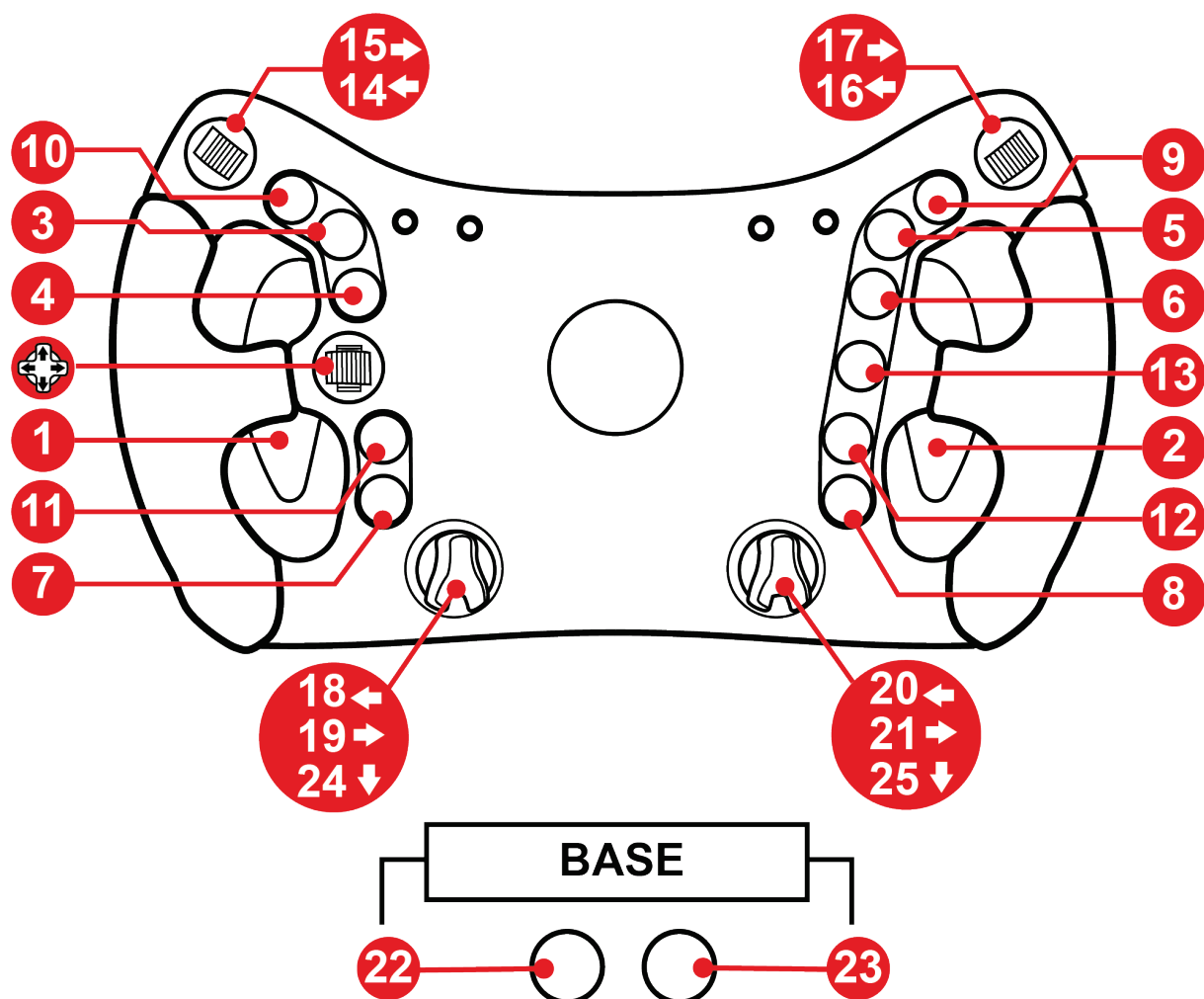



PS4™/PS5™ 用マッピング

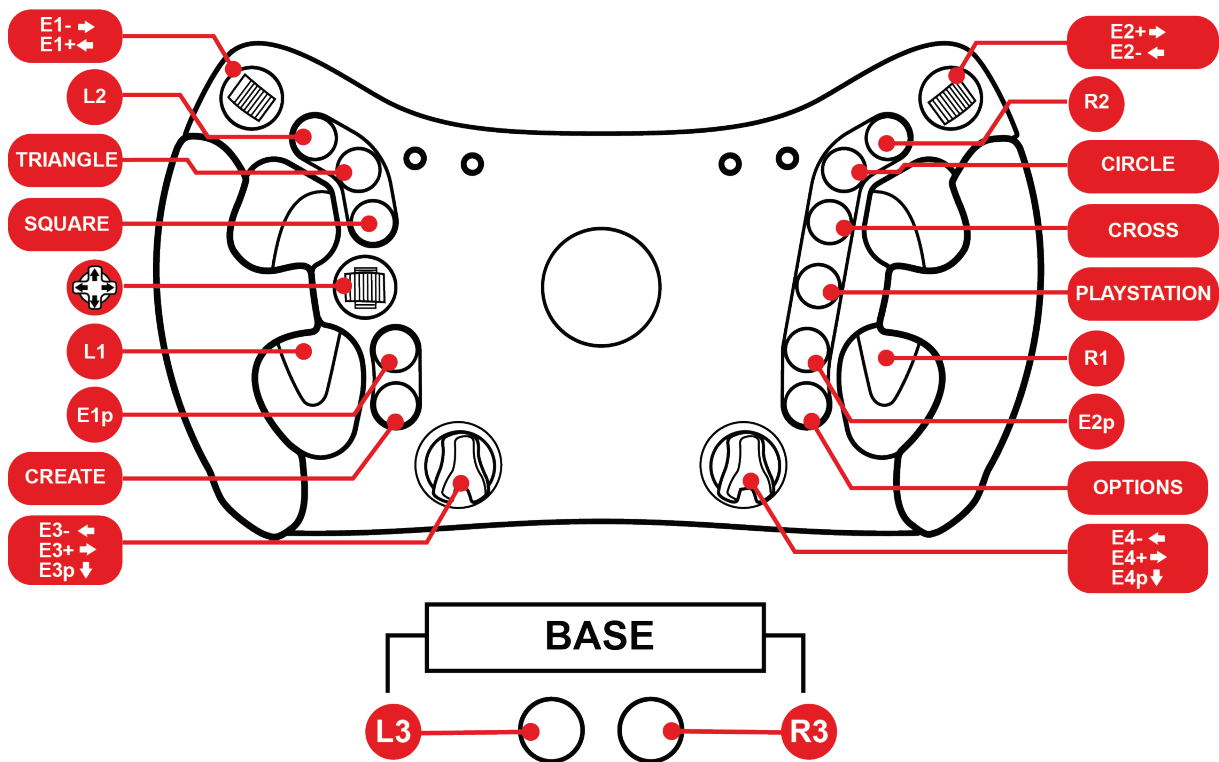



Xbox Series/Xbox One 用マッピング

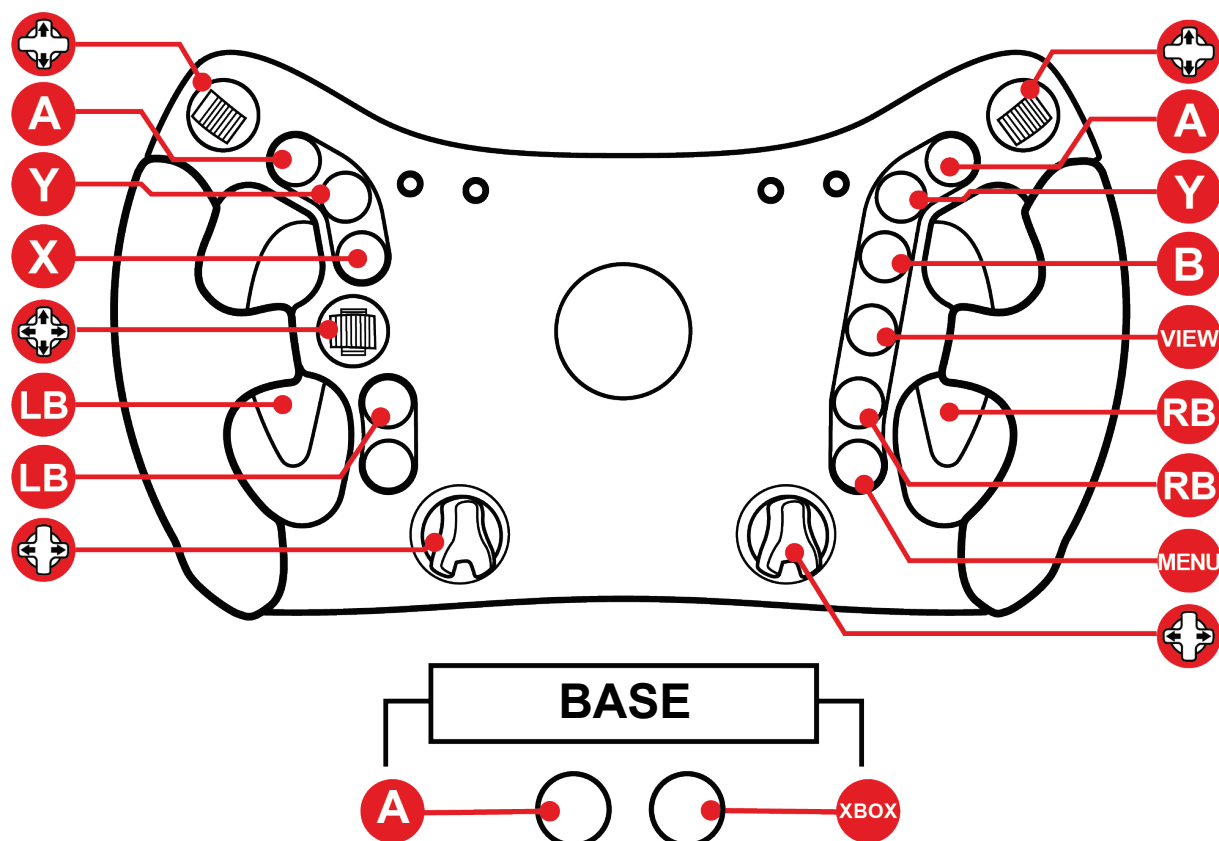

Xbox Series および Xbox One:

- Ferrari 488 GT3 Wheel Add-On の LED は、ゲーム機本体のプロトコルの制限により機能しません。
- 一部の機能（エンコーダー、ボタン数）は、ゲーム機本体のプロトコルによって制限されます。



6. LED 動作

Ferrari 488 GT3 Wheel Add-On は、レースデータ (フラッグ、ピット、RPM) を LED で表示します。

表示するデータは、モード (GT3 または Formula) に応じてカスタマイズできます (RPM LED の明るさと色)。

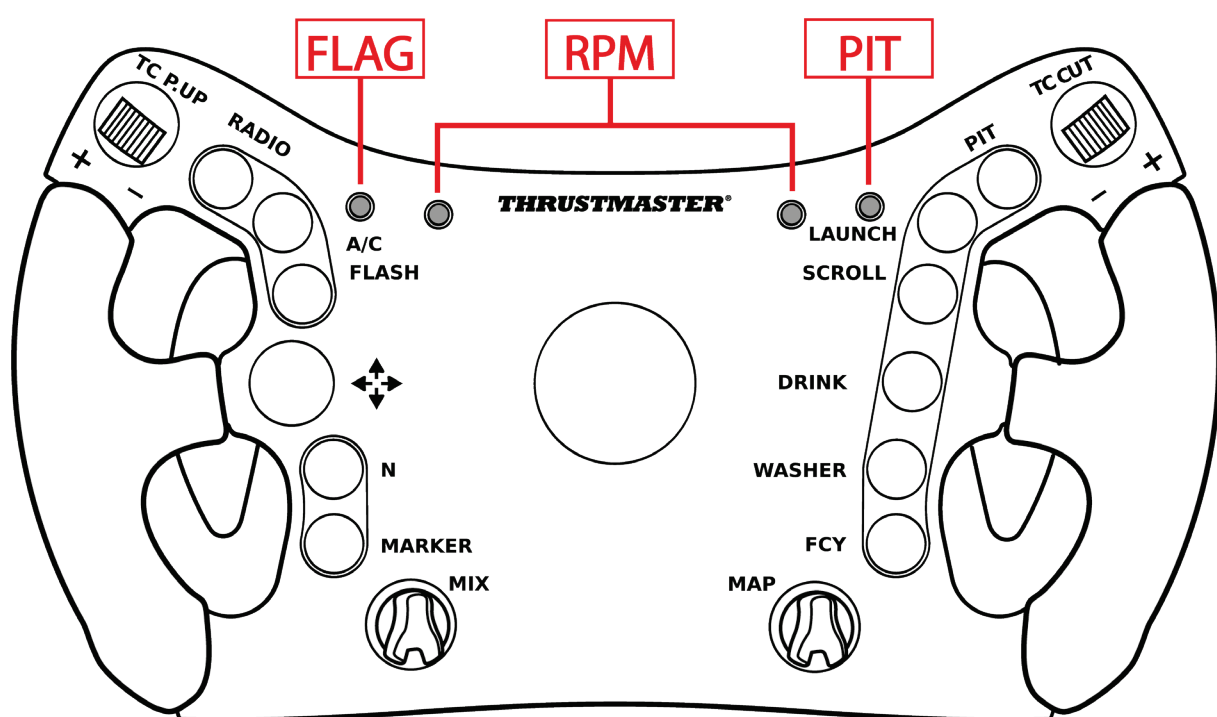

LED は PC および PS4™/PS5™ で機能します。

Xbox Series および Xbox One では、ゲーム機本体のプロトコル制限により LED は機能しません。



LED メニューへの入り方/閉じ方

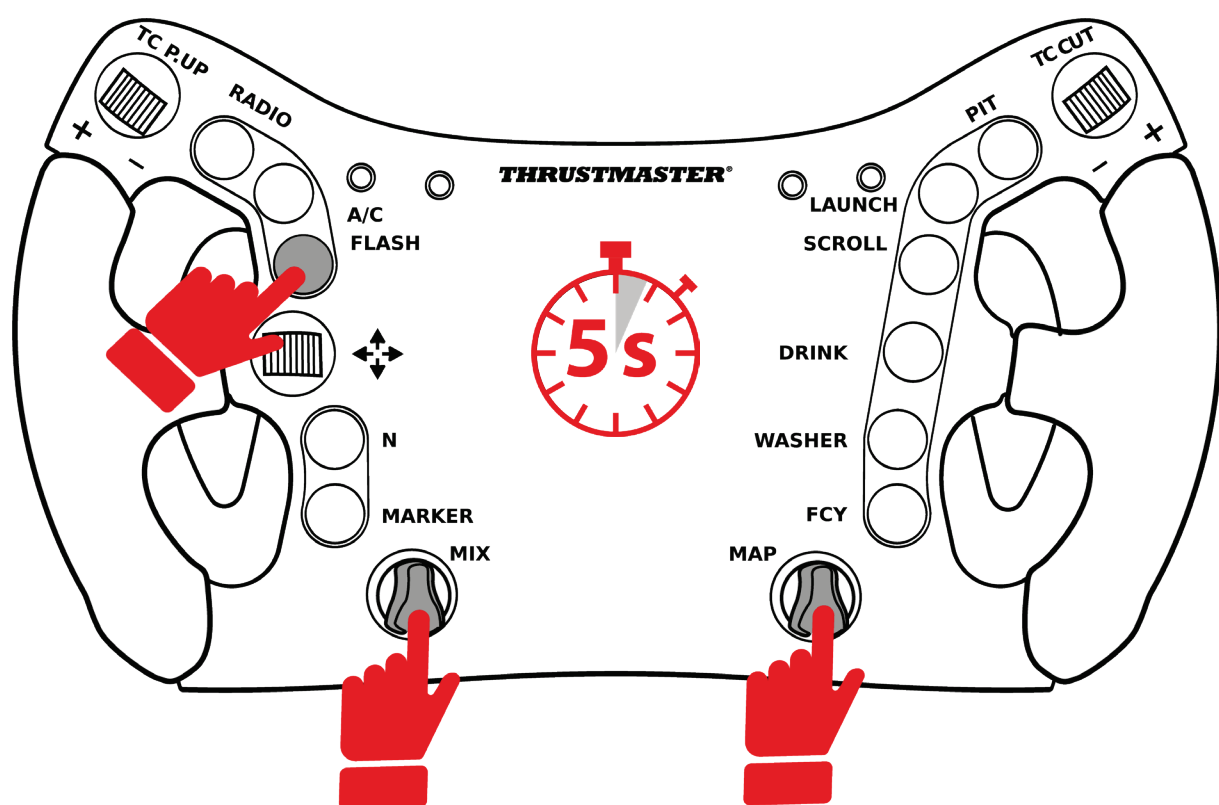

- LED メニューに入るには、FLASH ボタンと両方のロータリーエンコーダーを 5 秒間同時押ししてから離します。

- LED メニューを終了するには、FLASH ボタンと両方のロータリーエンコーダーを同時に押ししてから離します。

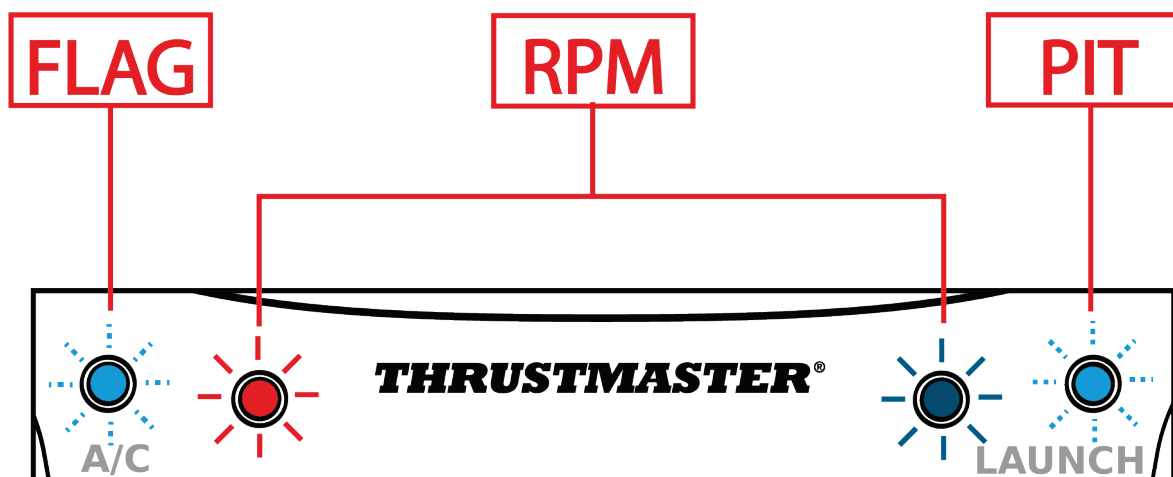

LED メニューに入ります: FLAG および PIT LED と、RPM LED のいずれか (左は赤、右は青) が点灯します。



LED メニューを終了する: 4 つの LED がすべて消灯します。



LED 強度の調整方法

- FLASH ボタンと両方のロータリーエンコーダーを 5 秒間同時押ししてから離して LED メニューに入ります。
- 左のエンコーダー (MIX) を左に回すと強度が下がり、右に回すと強度が上がります。



- FLASH ボタンと両方のロータリーエンコーダーを同時に押してから離して LED メニューを終了します。



LED モードの変更方法: GT3 または Formula

- FLASH ボタンと両方のロータリーエンコーダーを 5 秒間同時押ししてから離して LED メニューに入ります。
- 右エンコーダー (MAP) を 左に回すと GT3 モード (赤色 LED)、右に回すと Formula モード (青色 LED) が選択されます。



GT3 モード (デフォルトモード)



FORMULA モード

- FLASH ボタンと両方のロータリーエンコーダーを同時に押ししてから離して LED メニューを終了します。



7. パドルシフターのカスタマイズ

Ferrari 488 GT3 Wheel Add-On のパドルシフターは、間隔とリーチを調整することが可能です。

スペーシングとは、パドルシフターの幅を調整することで、グリップとパドルシフター間の距離を変更することです。

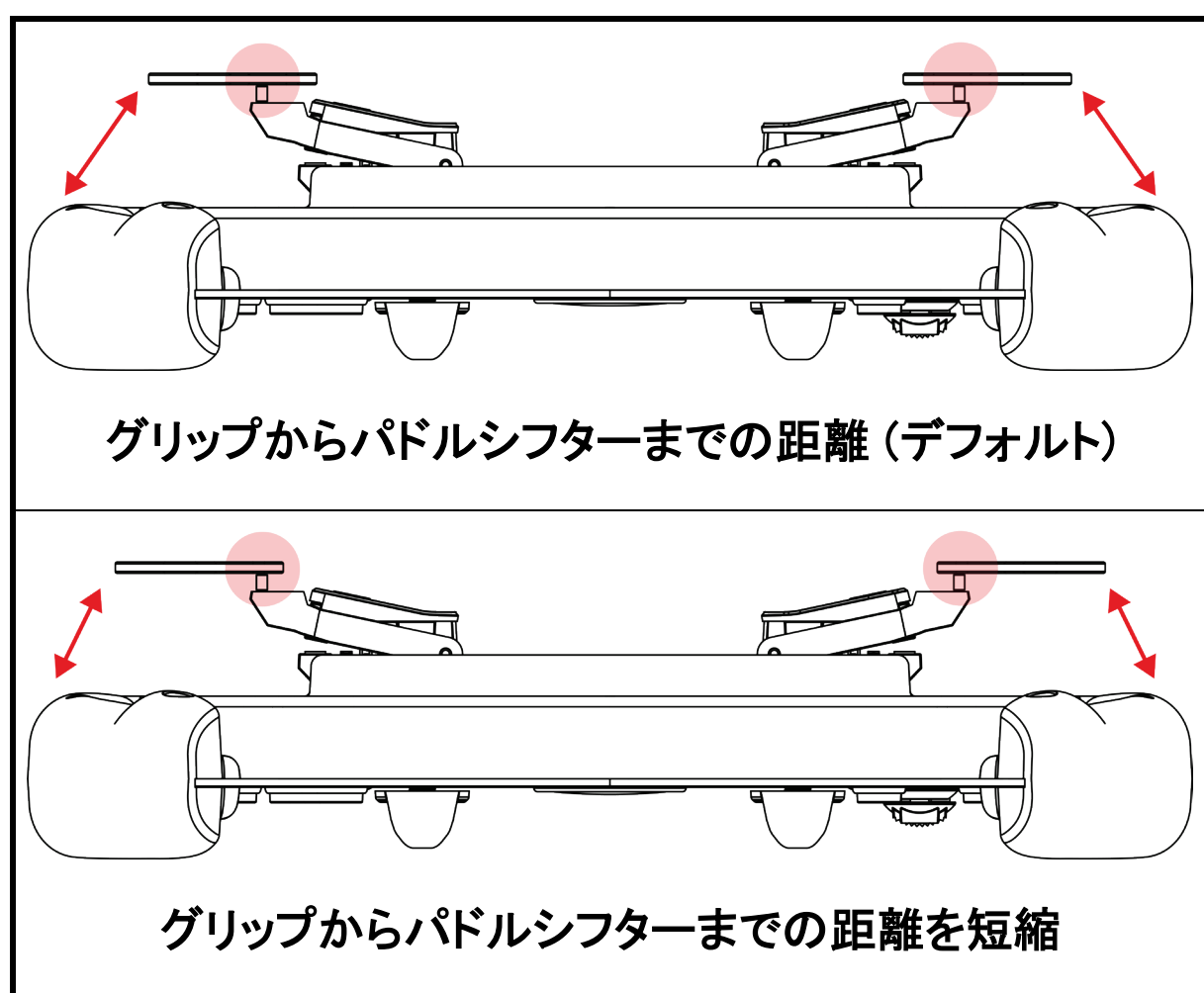



スペーサーを使ってリーチを調整することで、パドルシフターの作動距離を変更できます。

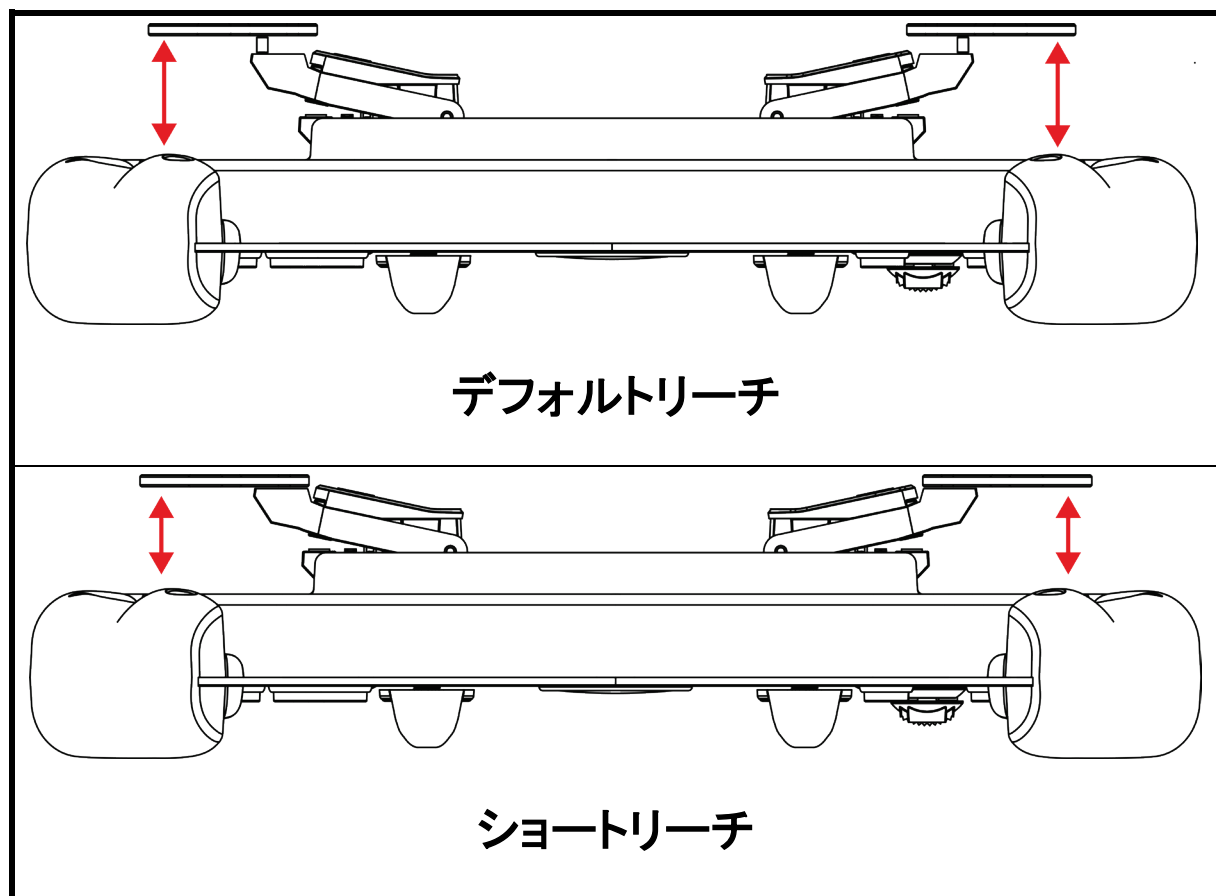

また、付属のパッドを使って、パドルシフターの磁気感度や音の大きさを調整することも可能です。

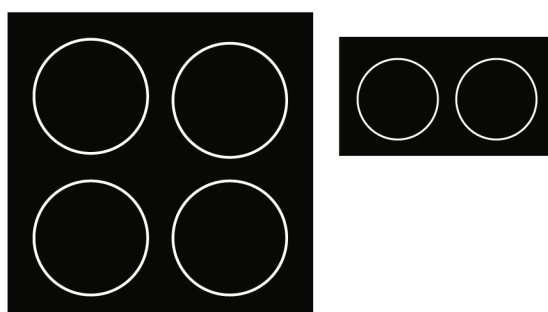



パドルシフターの間隔を調整する方法

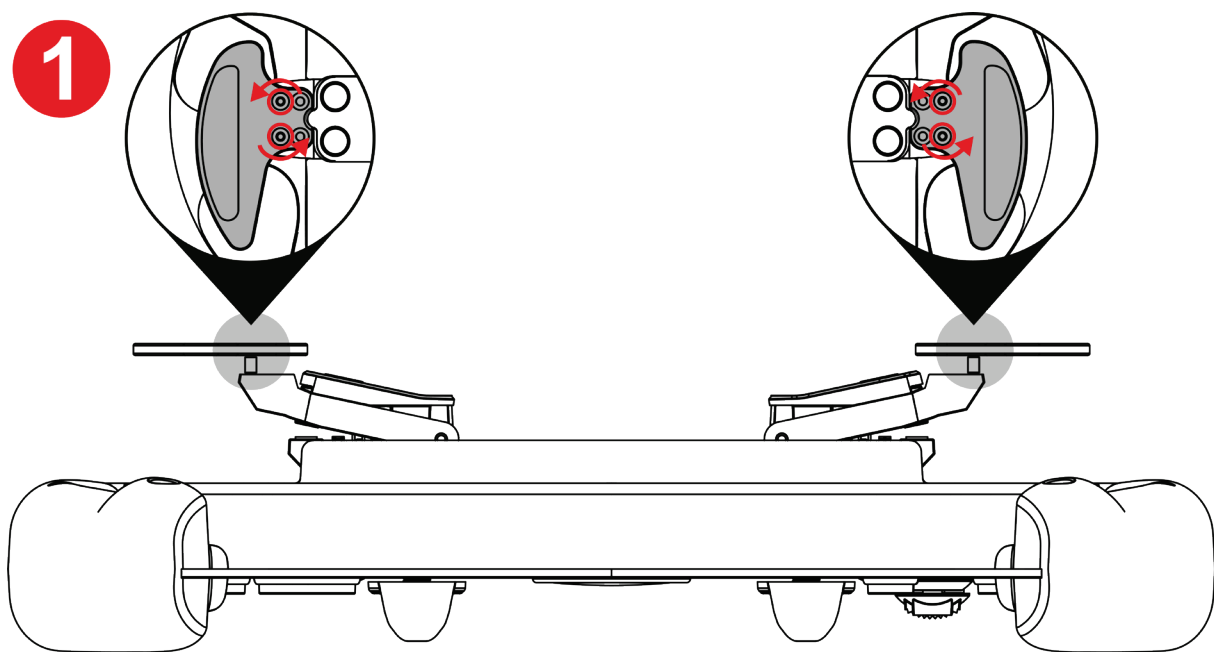

1 付属のトルクスレンチを使用して、4 本のパドルシフターねじを外します。

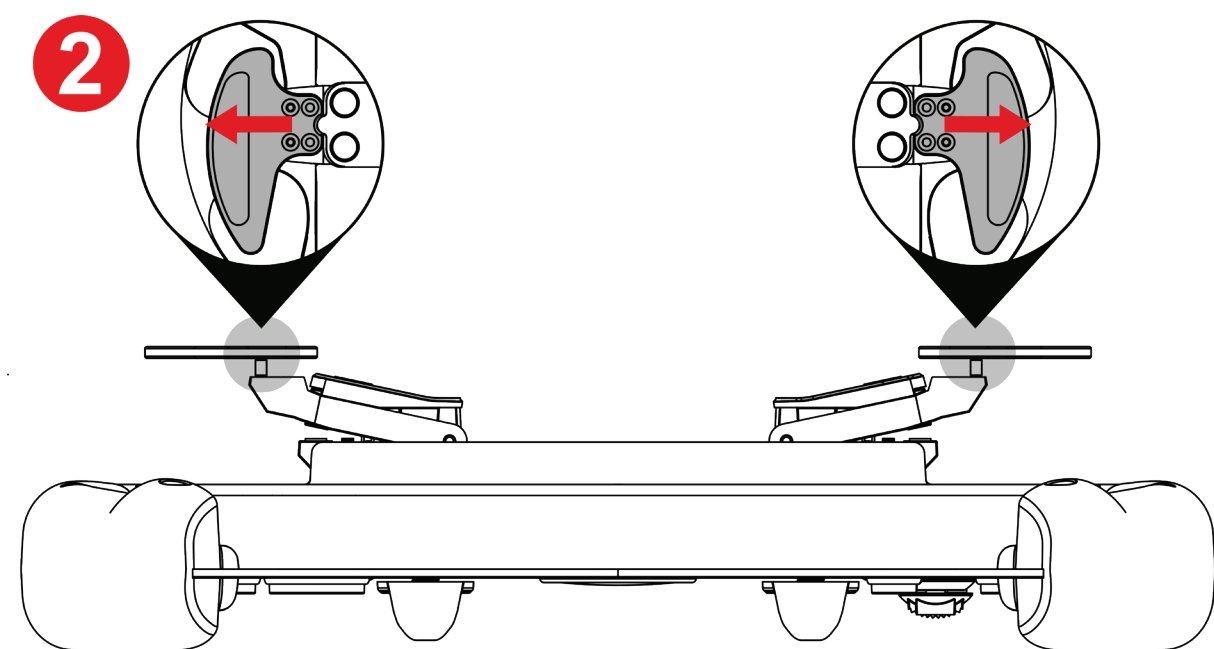

2 パドルシフターを外側にずらして穴の位置を合わせます。

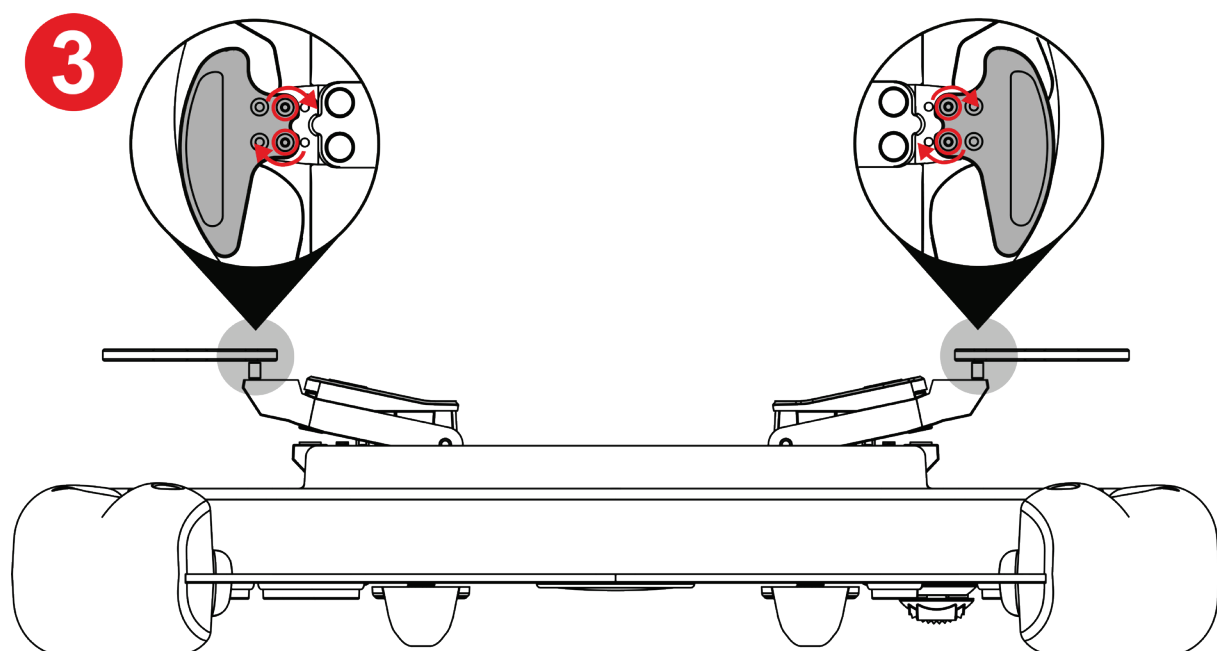

③ 付属のトルクスレンチを使用して、4本のパドルシフターねじを締めます。



パドルシフターのリーチを調整する方法

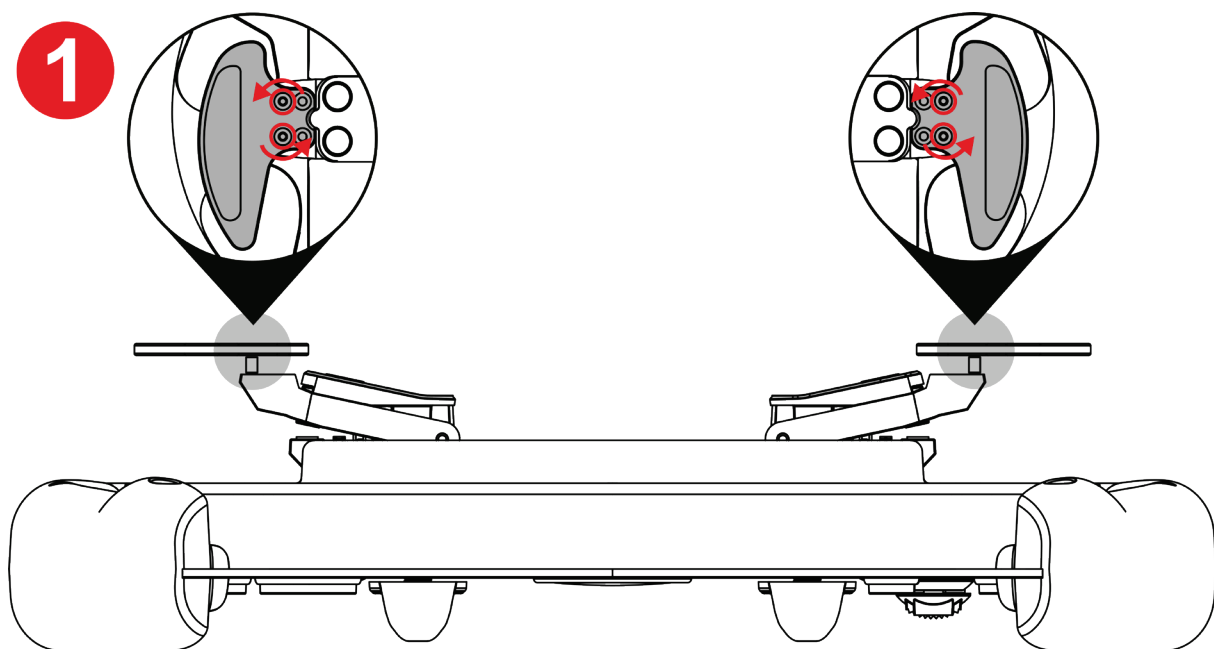

1 付属のトルクスレンチを使用して、4 本のパドルシフターねじを外します。

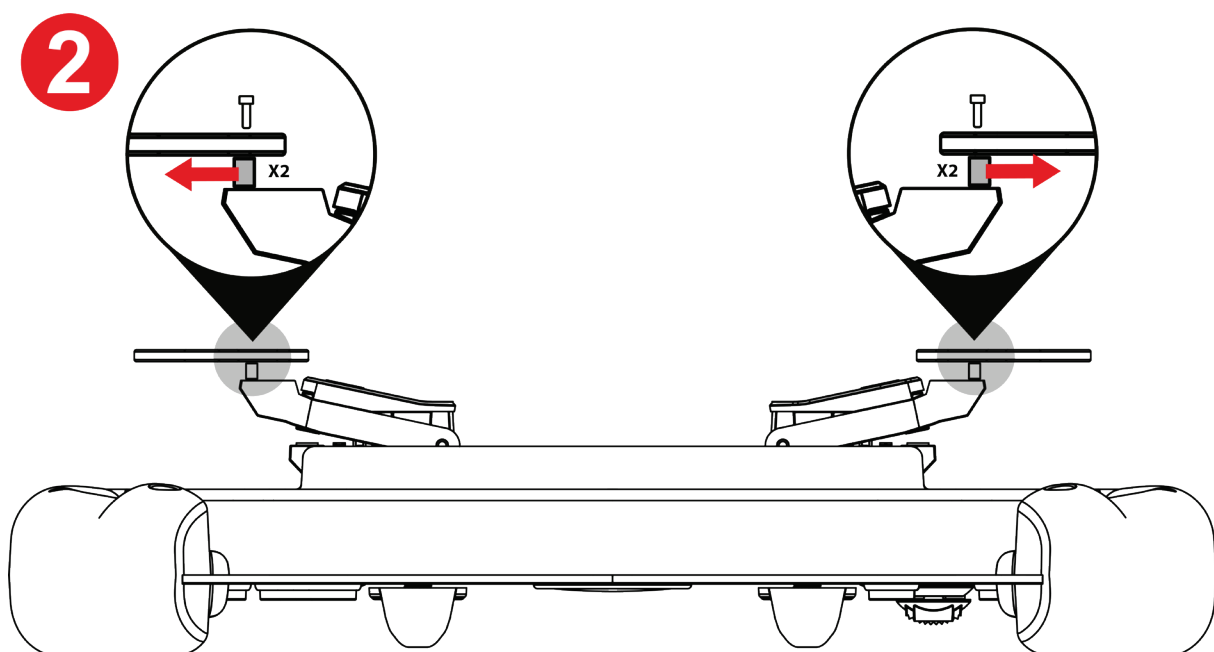

2 スペーサーを取り外します。

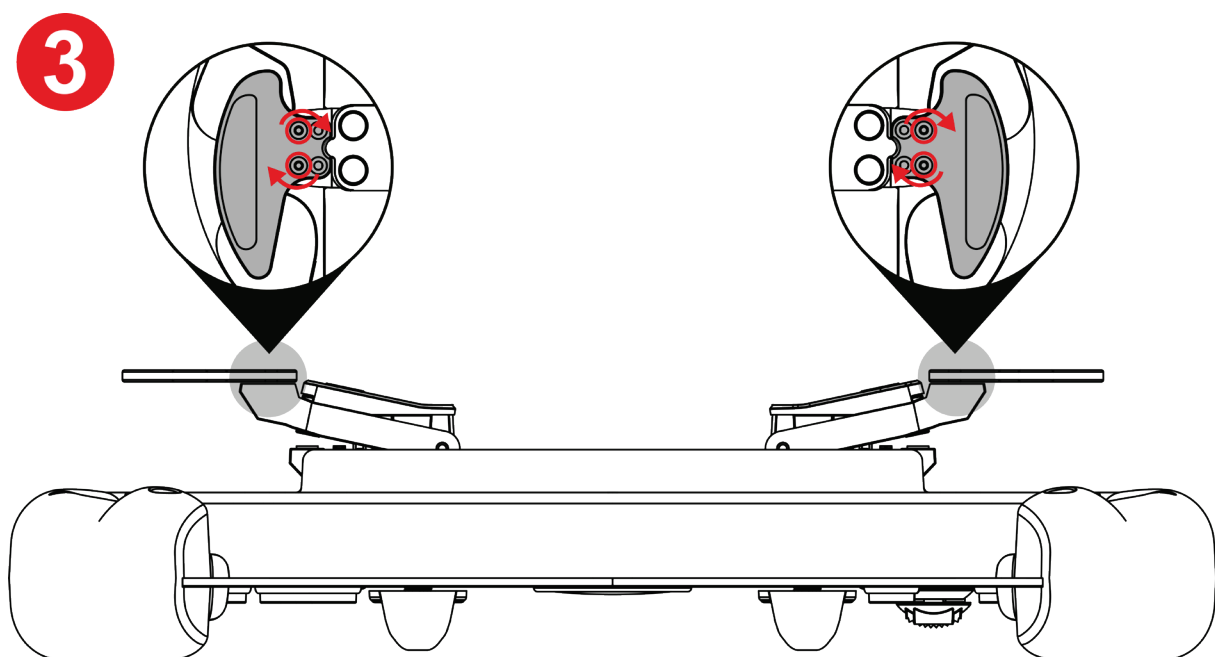

③ 付属のトルクスレンチを使用して、4本のパドルシフターねじを締めます。



パドルシフターの磁気感度とサウンドレベル の調整方法

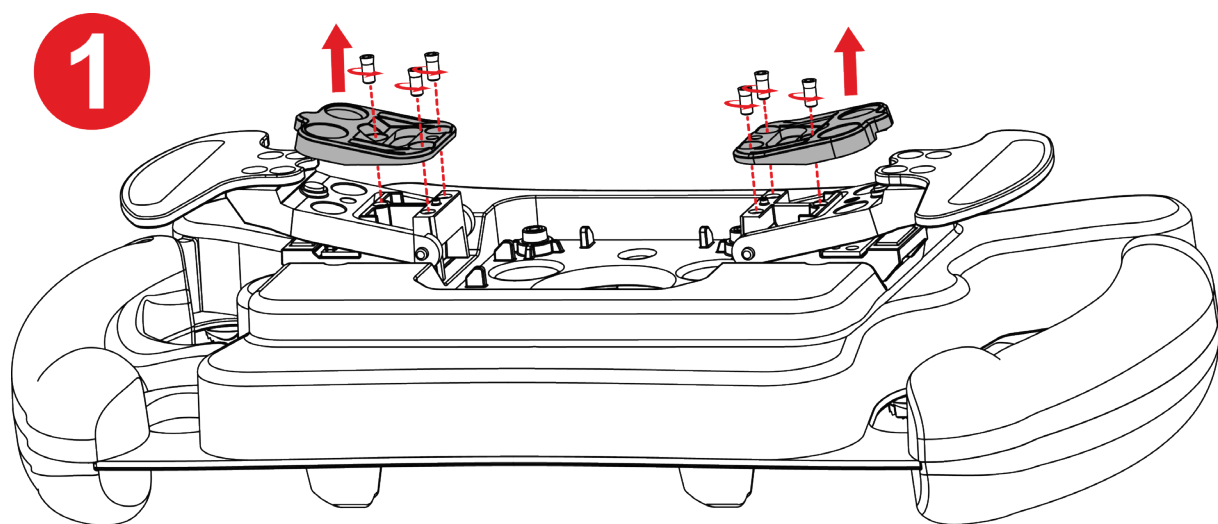

① 付属のトルクスキーを使って 6 本のストップねじを緩め、磁気ストップを取り外します。

2

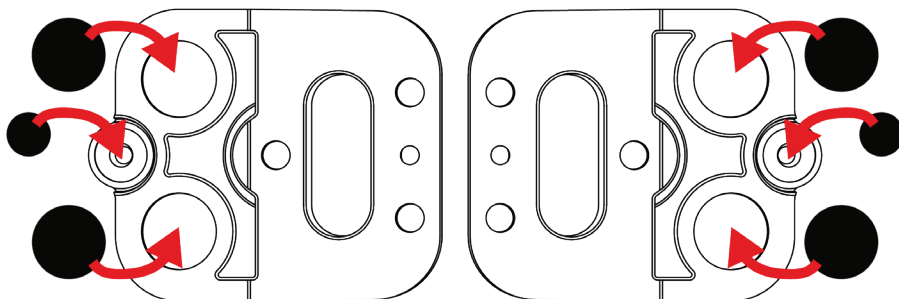
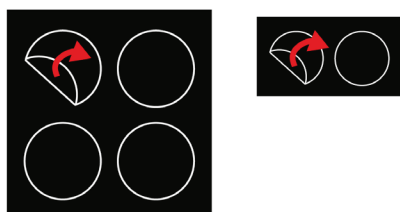

② 付属のパッドをはがし、磁気ストップの下の適切な場所に貼り付けます。



各エフェクトの構成については、**磁気感度とパドルシフター一音の減衰表**を参照してください。



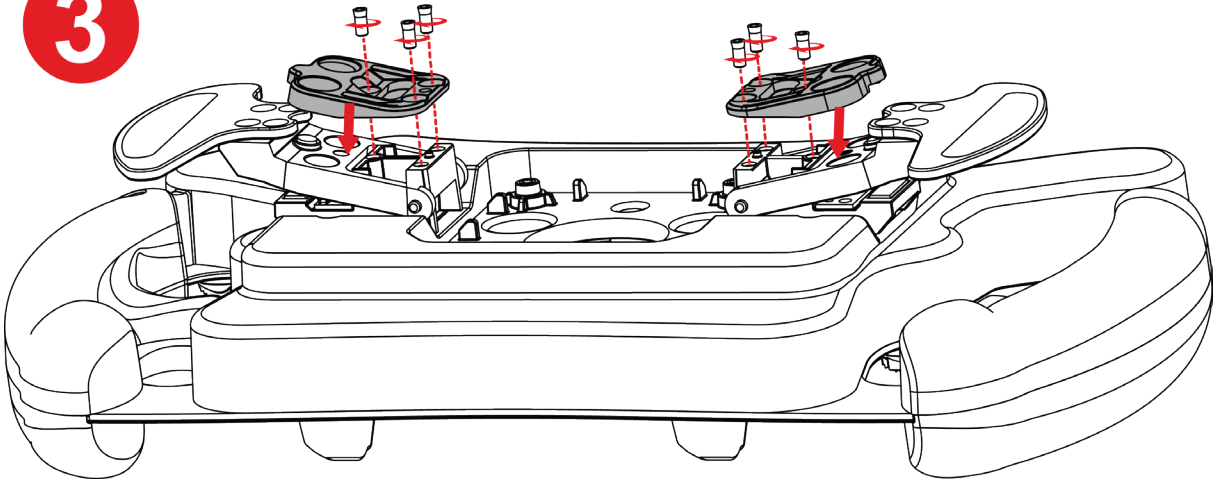

3

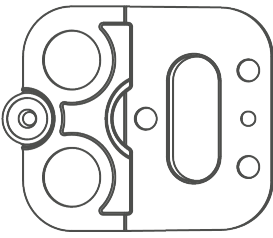
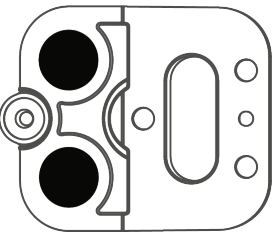
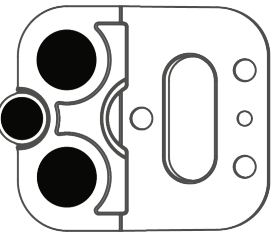
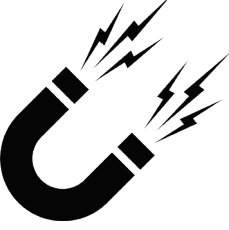

③ 磁気ストップを再び取り付け、付属のトルクスレンチを使用して6本のストップねじを締めます。

磁気の感度とパドルシフター音の減衰表

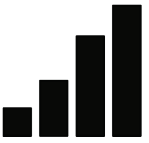
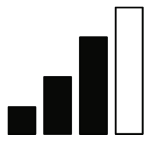
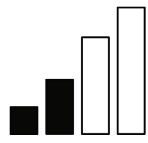
	 (デフォルト)		
磁気感度			
サウンド			



8. FAQ とテクニカルサポート

Ferrari 488 GT3 Wheel Add-On についてご質問がおりますか、それとも技術的な問題が発生していますか？そのような場合は、Thrustmaster テクニカルサポートのウェブサイト
にアクセスしてください:

<https://support.thrustmaster.com/product/ferrarif488gt3addon>.

このページでは、ステアリングコントローラーのファームウェアをアップデートすることもできます。



THRUSTMASTER®

FERRARI 488 GT3 WHEEL ADD-ON

图马思特法拉利 488 GT3 赛车模拟器盘面

PC (Windows 10/11)

PS4™ / PS5™

Xbox Series / Xbox One

用户手册



在安装本产品之前、以任何方式使用本产品之前以及对其执行任何维护之前，请仔细阅读本手册提供的说明。请务必遵守安全说明。不遵守这些说明可能导致事故和/或损坏。请保留本手册，以便您日后查阅说明。

目录

1.	包装清单	5
2.	特性	6
3.	有关方向盘使用的信息	8
4.	安装快拆支架	13
	<i>安装适用于闩锁式底座的快拆支架</i>	<i>14</i>
	<i>安装适用于螺纹式底座的快拆支架</i>	<i>17</i>
5.	映射	21
	<i>针对 PC 进行映射</i>	<i>21</i>
	<i>针对 PS4™/PS5™ 进行映射</i>	<i>22</i>
	<i>针对 Xbox Series/Xbox One 进行映射</i>	<i>23</i>
6.	LED 的运行	24
	<i>如何进入/退出 LED 菜单</i>	<i>25</i>
	<i>如何调节 LED 亮度</i>	<i>27</i>
	<i>如何更改 LED 模式: GT3 或 Formula</i>	<i>28</i>

7.	定制换挡拨片	29
	<i>如何调整换挡拨片的间距.....</i>	31
	<i>如何调整换挡拨片的行程范围</i>	33
	<i>如何调整磁性灵敏度和换挡拨片的音量.....</i>	35
8.	常见问题解答和技术支持.....	37



FERRARI 488 GT3 WHEEL ADD-ON

借助 Ferrari 488 GT3 Wheel Add-On 加入传奇的 GT 赛车，该产品是一款专为性能而设计的方向盘，兼容所有 Thrustmaster（图马思特）方向盘底座。

本手册将帮助您安装 Ferrari 488 GT3 Wheel Add-On 并让其运行在最佳条件下。在开始赛车之前，请仔细阅读说明和警告：它们将帮助您尽情享受您的产品。



1. 包装清单

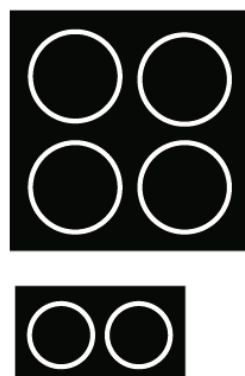
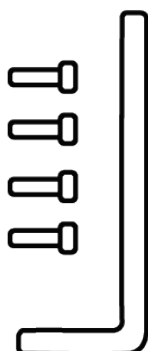
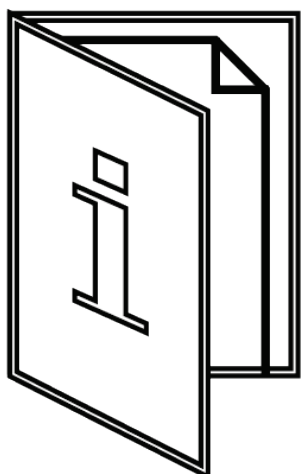
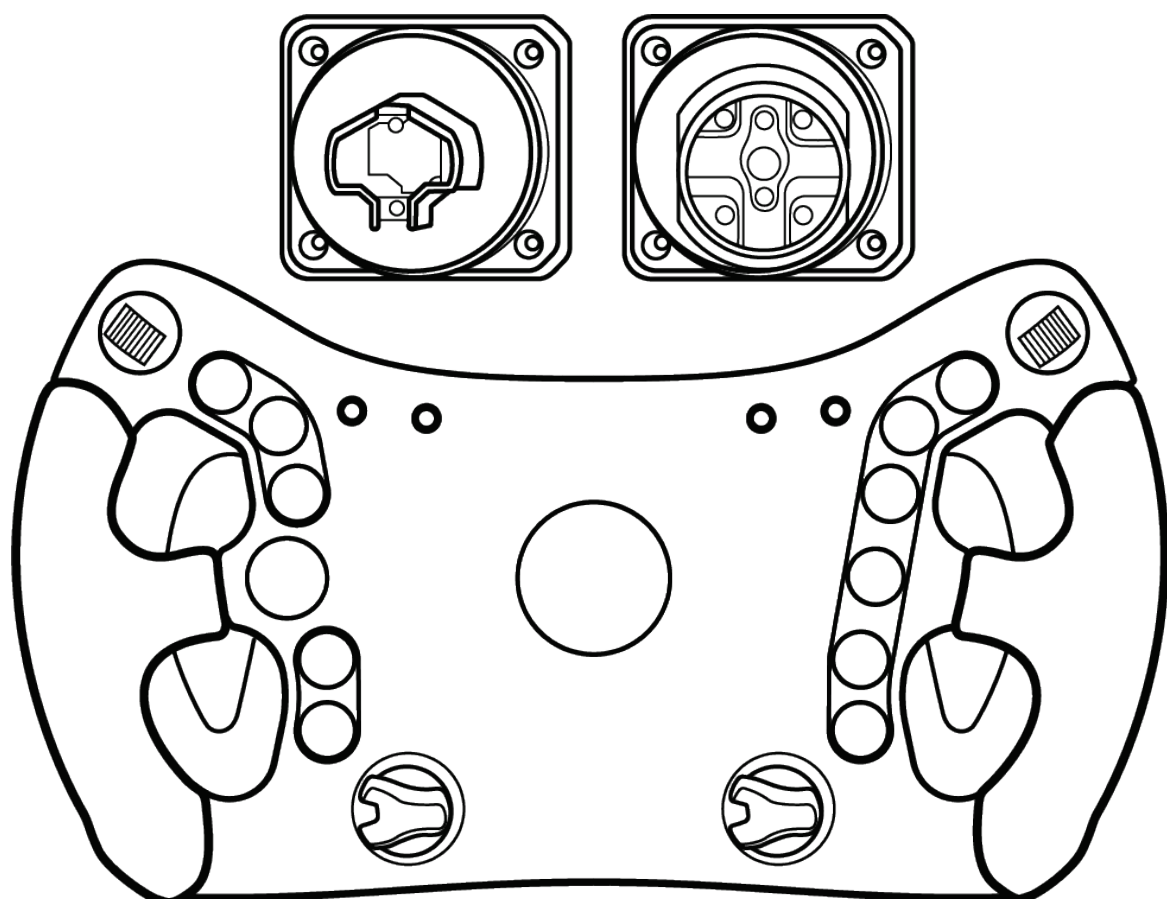



2. 特性

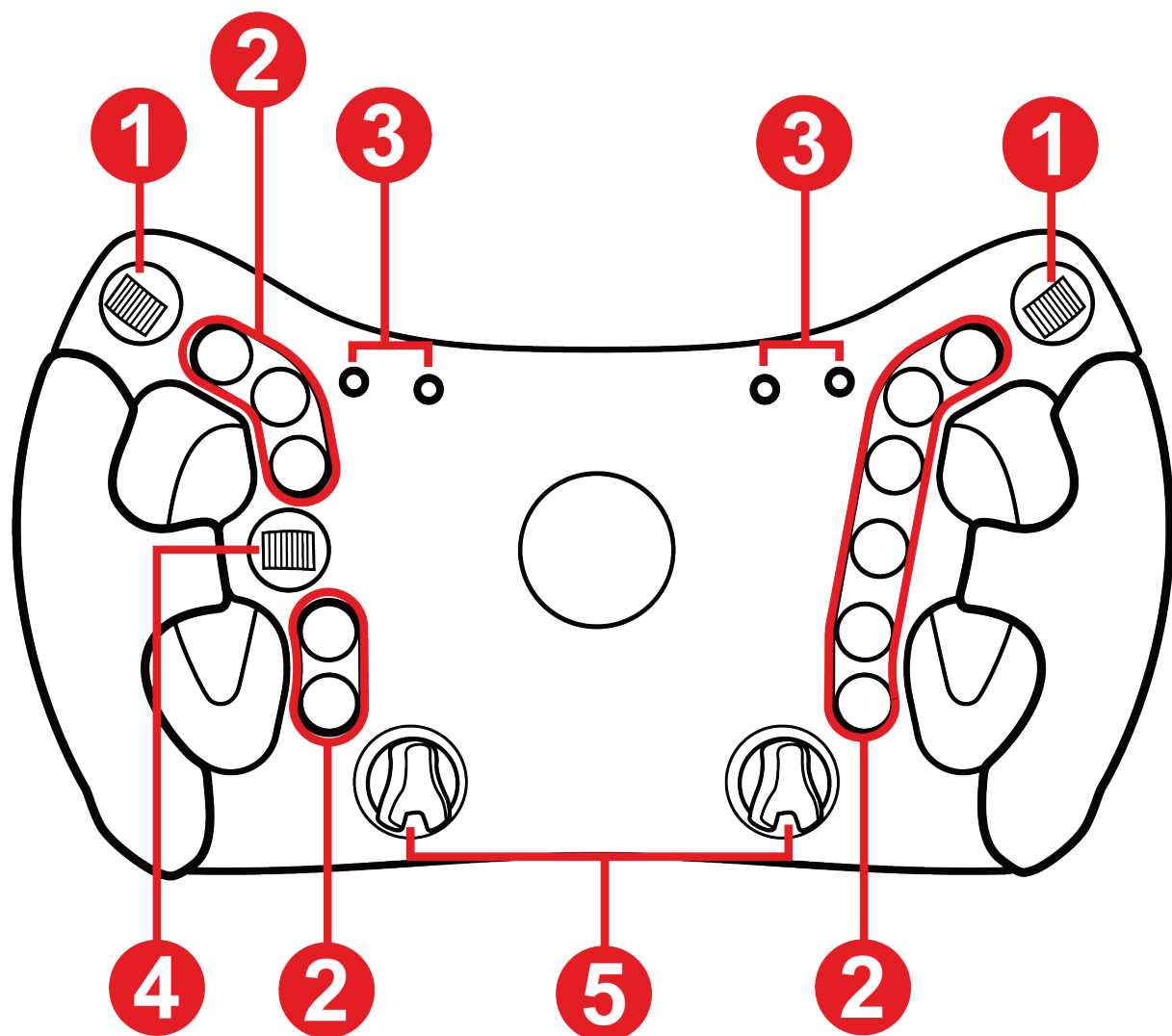

- ❶ 拇指编码器
- ❷ 11 个操作按钮
- ❸ RPM LED 和赛车数据（旗帜、检修区）
- ❹ D-pad 方向键
- ❺ 旋转编码器

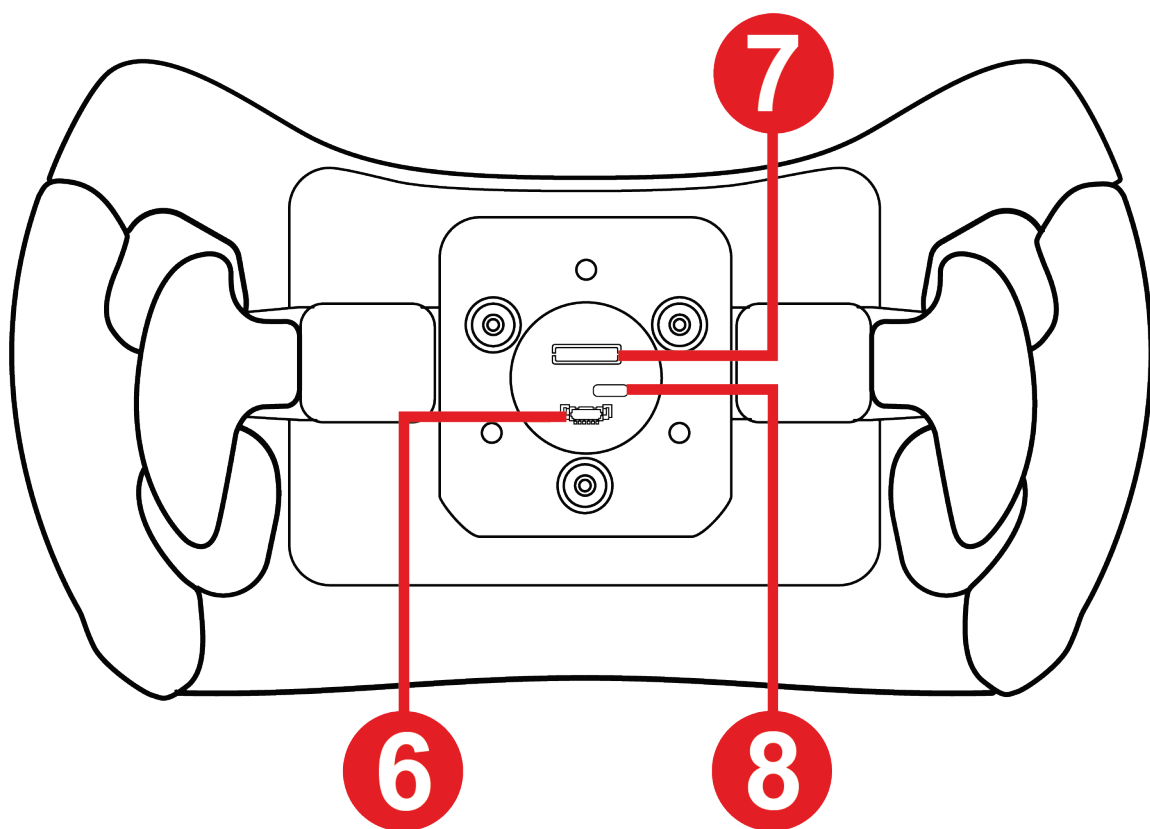

⑥ 连接端口，用于连接适用于螺纹式底座的快拆支架

⑦ 连接端口，用于连接适用于闩锁式底座的快拆支架

⑧ USB-C 端口（需要固件更新时使用 — 不随附电缆）

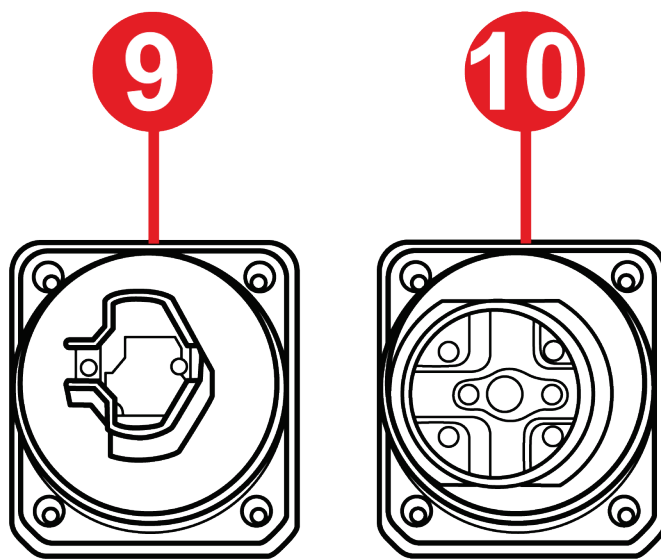

⑨ 适用于闩锁式底座的快拆支架

⑩ 适用于螺纹式底座的快拆支架



3. 有关方向盘使用的信息



文档

在使用本产品之前，请仔细重读本文档，并妥善保存以备日后参考。



触电

- 请将本产品置于干燥的位置，切勿将其暴露在灰尘或阳光中。
- 切勿扭曲或拉扯接头和电缆。
- 按照所示连接方向连接各个组件。
- 切勿让任何液体溅到本产品或其接头上。
- 切勿造成本产品短路。
- 切勿拆解本产品（本手册中另有规定的情形除外）；切勿将其投入火中，亦勿将其暴露在高温环境中。
- 切勿拆开本设备：内部没有任何可由用户维修的零部件。任何维修工作均须由制造商、指定代理商或持证技工执行。



保护游戏区的安全

- 请勿在游戏区内放置任何可能扰乱用户练习的物体，或可能引起不适当的动作或被他人打断的物体（例如咖啡杯、电话、钥匙）。
- 请勿用地毯、小地毯、毛毯、覆盖物或任何其他物品覆盖电源线，也不要将电源线布设在有人走动的地方。



因力反馈和重复运动造成的伤害

使用力反馈方向盘可能会造成肌肉或关节疼痛。为避免这些问题：

- 事先进行热身，并避免长时间的练习。
- 每练习一小时后休息 10 到 15 分钟。
- 如果手、手腕、手臂、脚或腿有任何疲劳或疼痛的感觉，请按下关闭力反馈按钮，关闭底座，休息几小时后再恢复练习。
- 如果恢复练习时仍然存在上述症状或疼痛感，应停止练习并就医。
- 请勿将力反馈强度设置为超出您的专业技能和身体状况的水平。
- 请勿让未满 16 岁的人接触本设备。
- 务必按照本手册的说明正确连接底座和方向盘。



发生不可预见的强力快速旋转的风险：切勿将手或手臂穿过方向盘轮毂的开口，或放入方向盘的旋转轨道上。

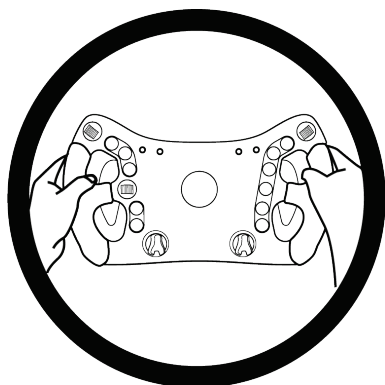

使用本产品时，应始终将双手正确放在方向盘上，不得完全离开方向盘。



本产品只能由年满 **16** 岁的用户操作。



4. 安装快拆支架

Ferrari 488 GT3 Wheel Add-On 随附两个快拆支架，分别对应两种不同类型的 Thrustmaster（图马思特）底座。

系统	兼容性
 <p>适用于闩锁式底座的快拆支架</p>	T818 、 T818 Ferrari SF1000 Simulator 以及未来的 Thrustmaster（图马思特）底座。
 <p>适用于螺纹式底座的快拆支架</p>	T-GT / T-GT II Servo Base 、 T300 RS Servo Base、 TS PC Racer、 TS-XW 、 TX Racing Wheel Servo Base、 TS-XW Servo Base。



在每次使用前，请按照本手册针对相应底座的说明确认 **Ferrari 488 GT3 Wheel Add-On** 仍然正确地固定到支架上。



安装适用于闩锁式底座的快拆支架

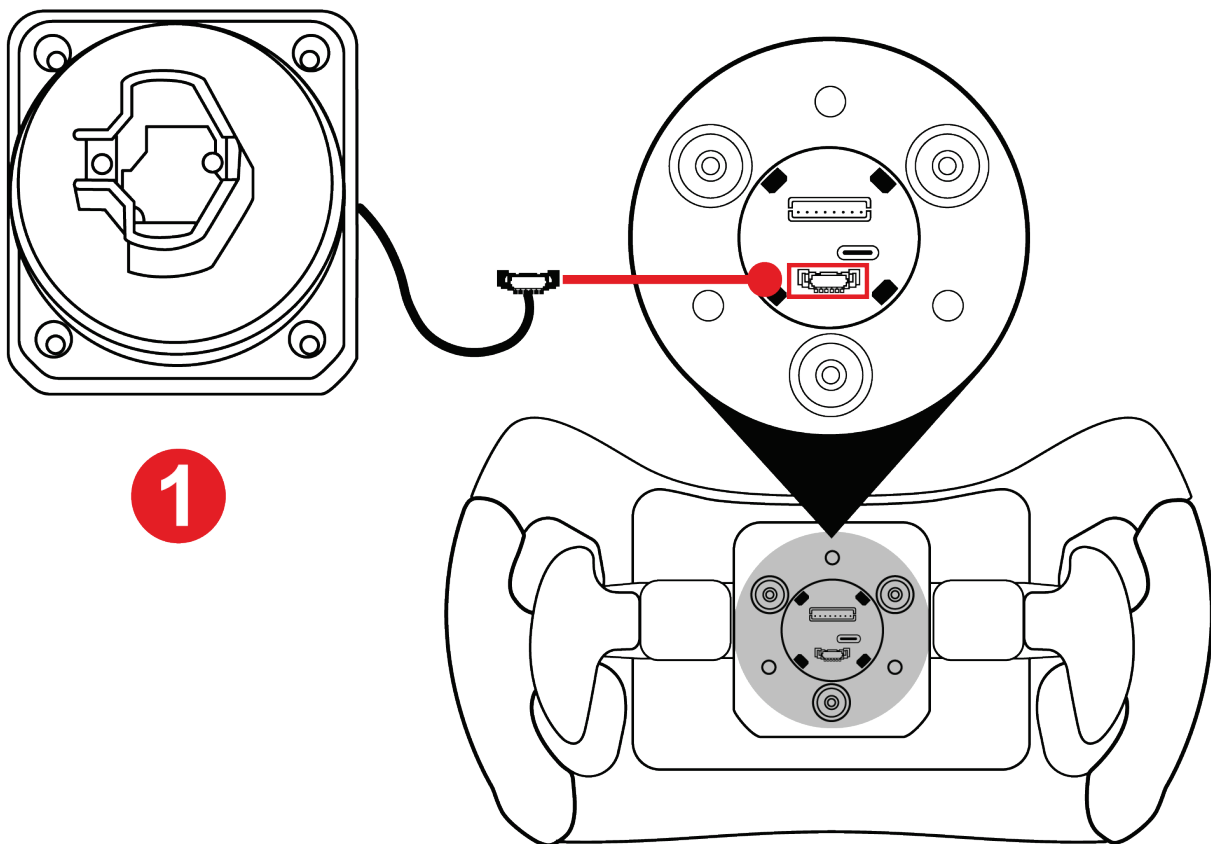

1

❶ 将快拆支架接头插入到方向盘背部的相应端口中。



为避免夹伤电缆，请在旋紧固定支架之前，先将电缆收回到电缆保护套中。

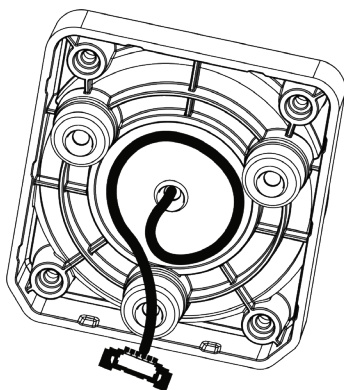

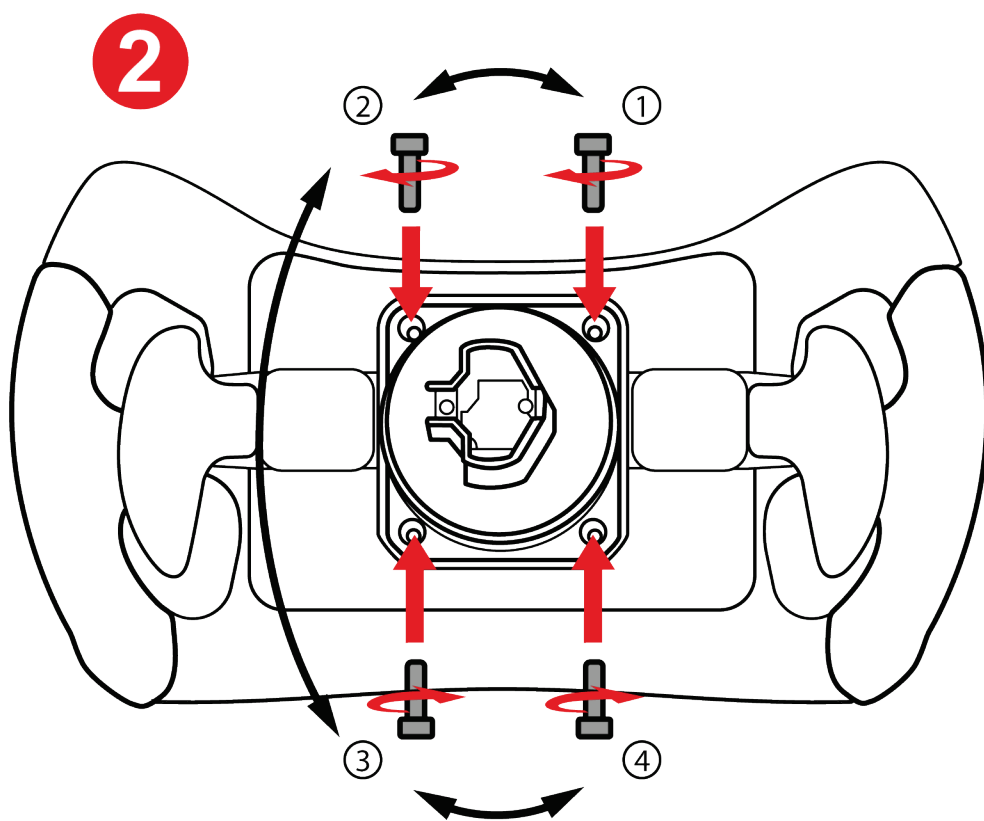

2 插入快拆支架并使用提供的梅花扳手拧紧支架。



在安装支架时，切勿过度拧紧螺丝。

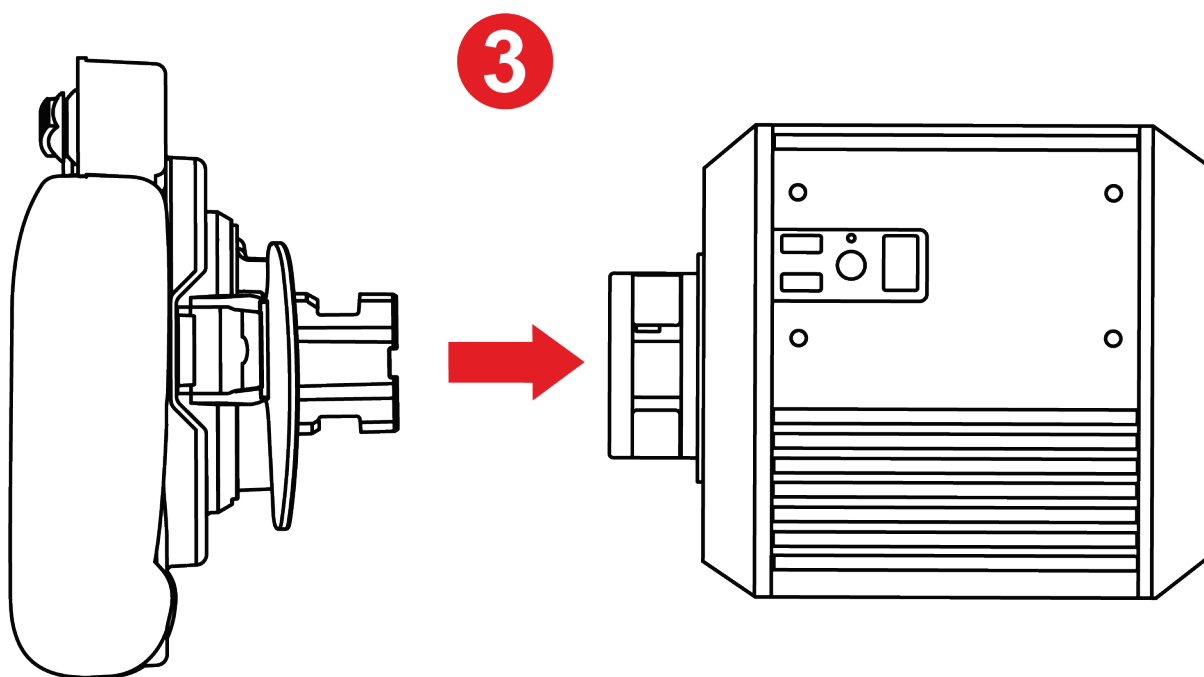

3 将方向盘安装到底座中。



按照底座用户手册中规定的安装程序操作。



安装适用于螺纹式底座的快拆支架

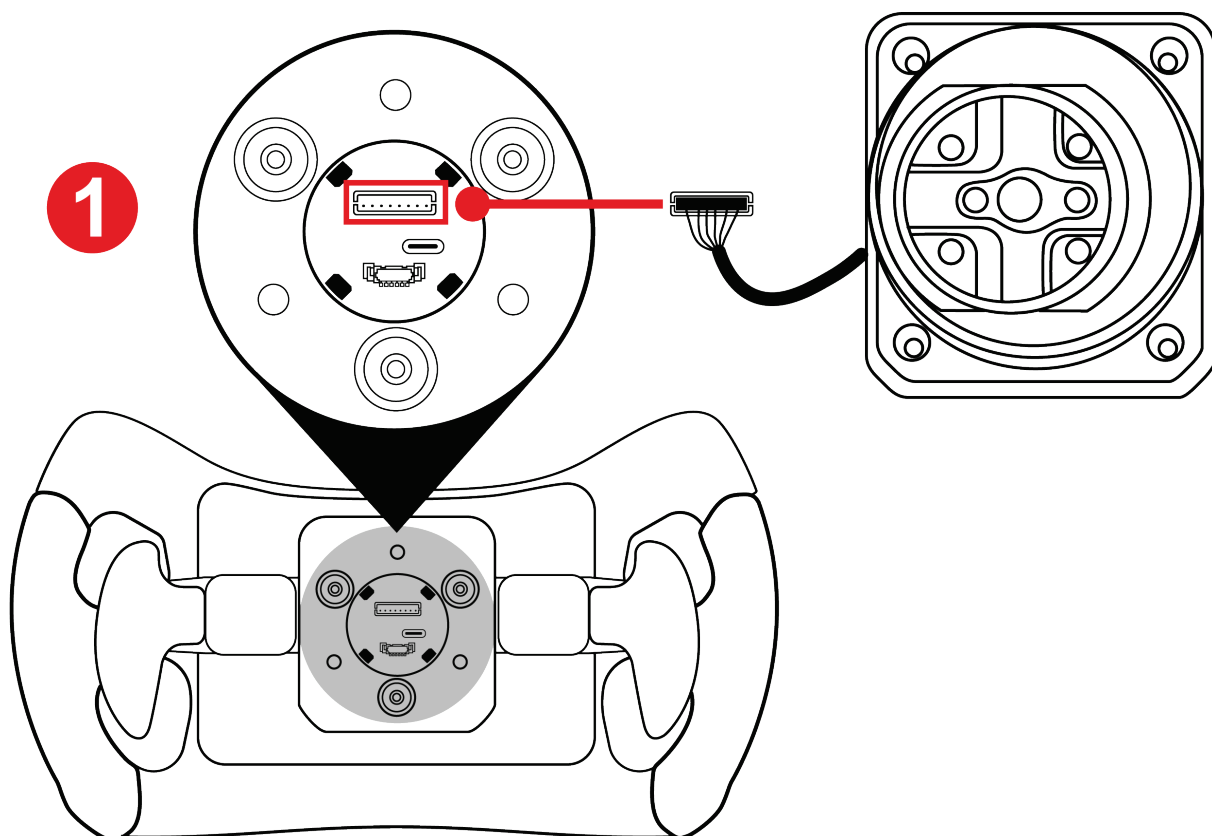

- 1 将快拆支架接头插入到方向盘背部的相应端口中。



为避免夹伤电缆，请在旋紧固定支架之前，先将电缆收回到电缆保护套中。

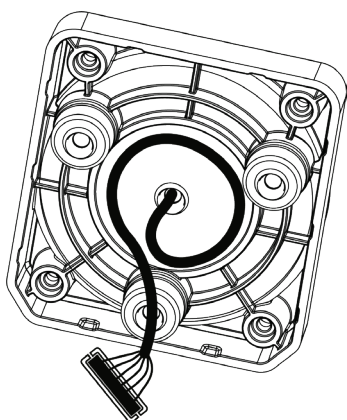

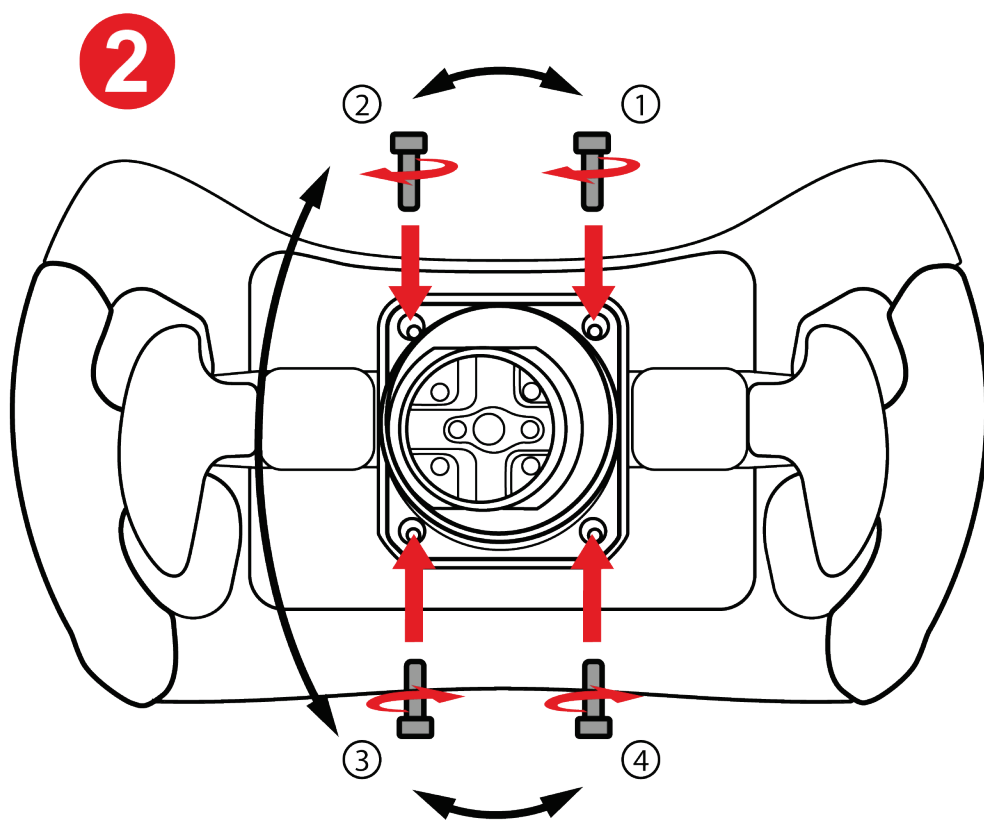

② 插入快拆支架并使用提供的梅花扳手拧紧支架。



在安装支架时，切勿过度拧紧螺丝。

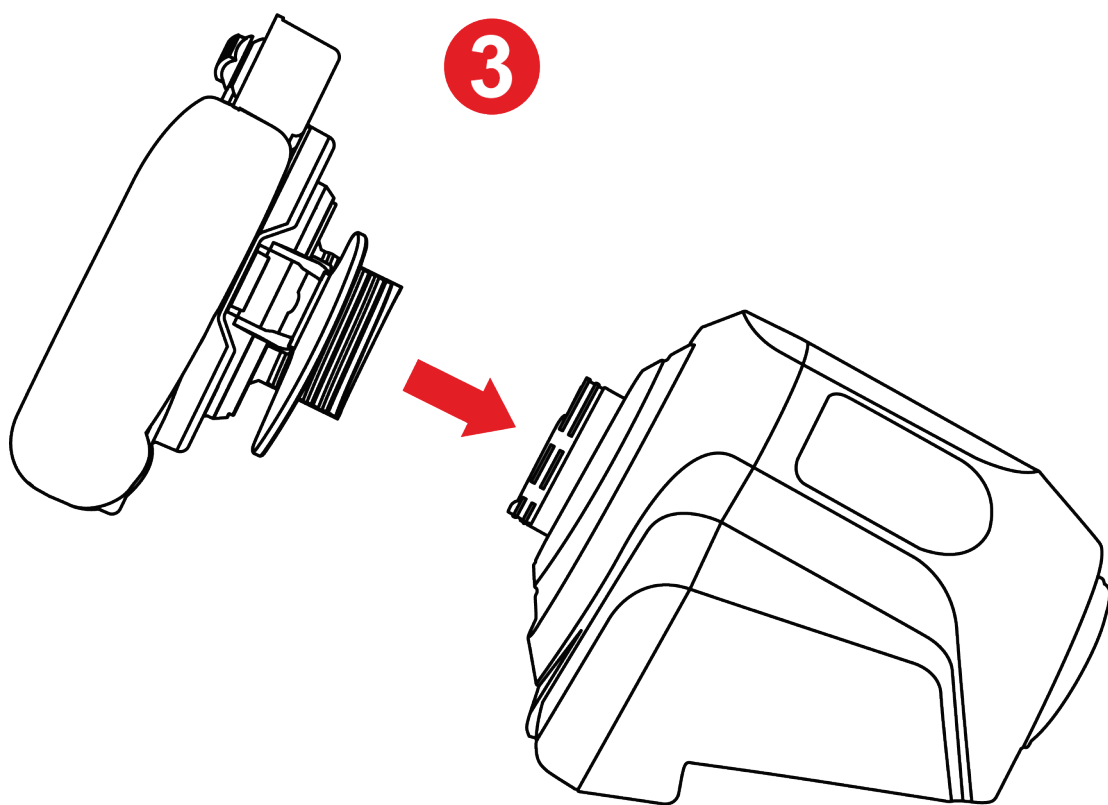

3 将方向盘安装到底座中。



按照底座用户手册中规定的安装程序操作。



如果您打算在 T818 底座上使用快拆转接头，切勿将快拆转接头（随 T818 底座提供，亦可单独出售）连接到适用于螺纹式底座的快拆支架。

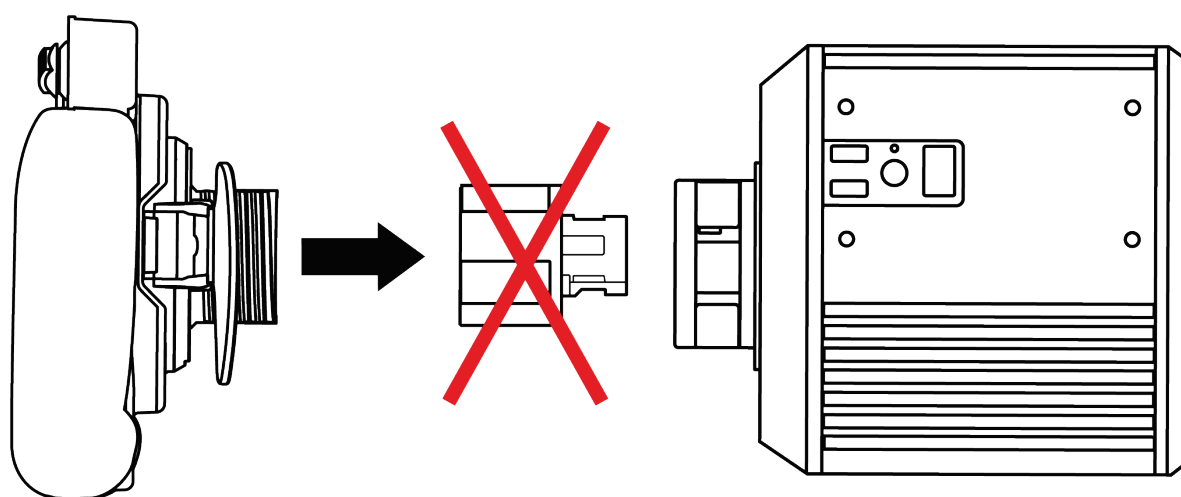
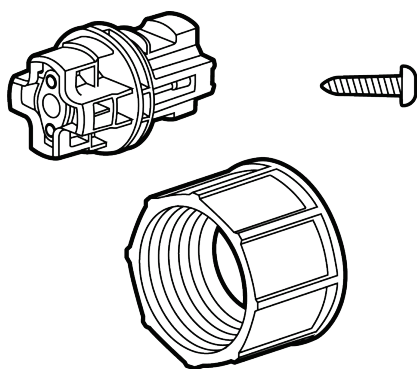

要在 T818 底座或配备闩锁式底座接头的底座上使用，请仅使用随 **Ferrari 488 GT3 Wheel Add-On** 提供的适用于闩锁式底座的快拆支架。



5. 映射

针对 **PC** 进行映射

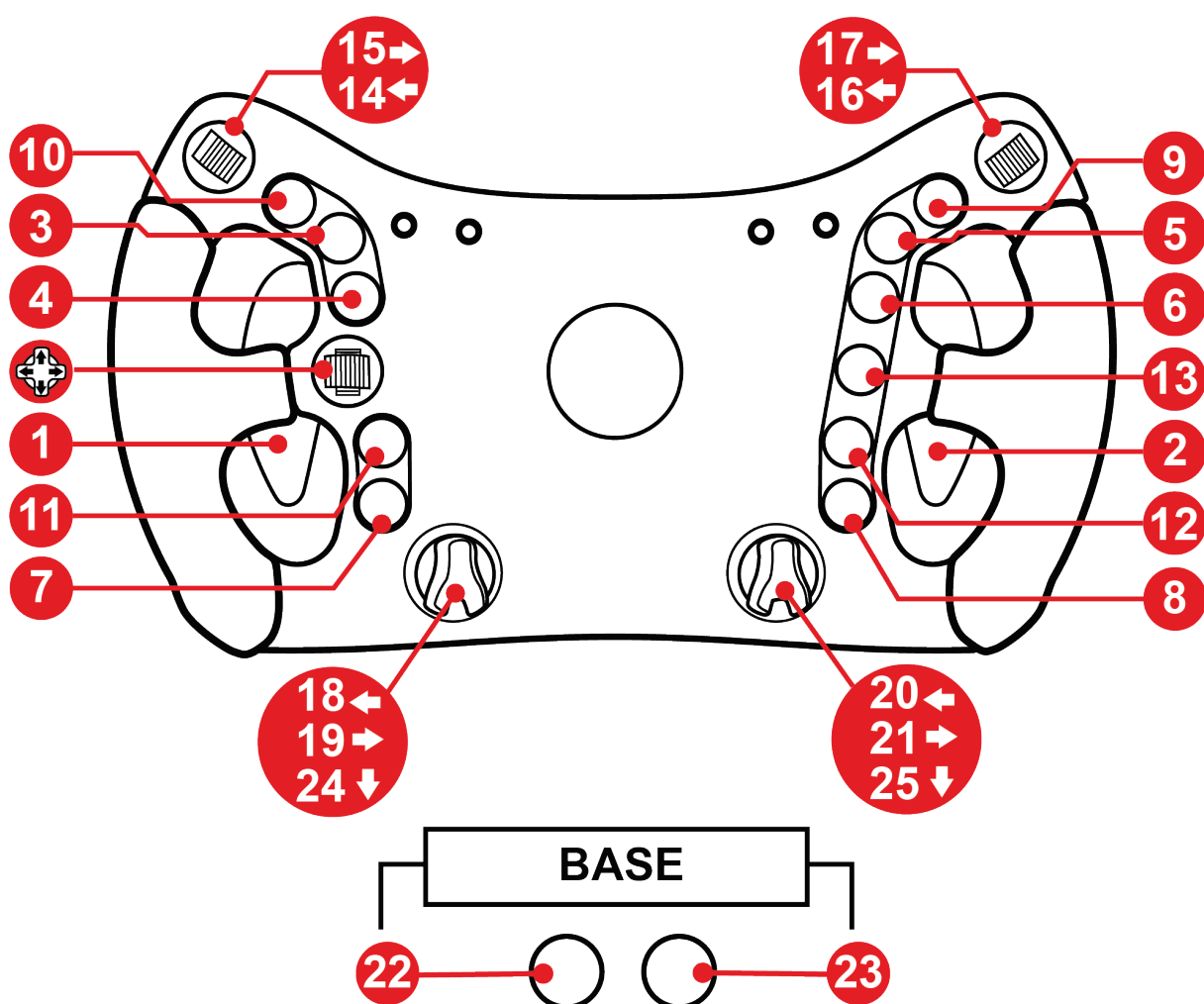



针对 PS4™/PS5™ 进行映射

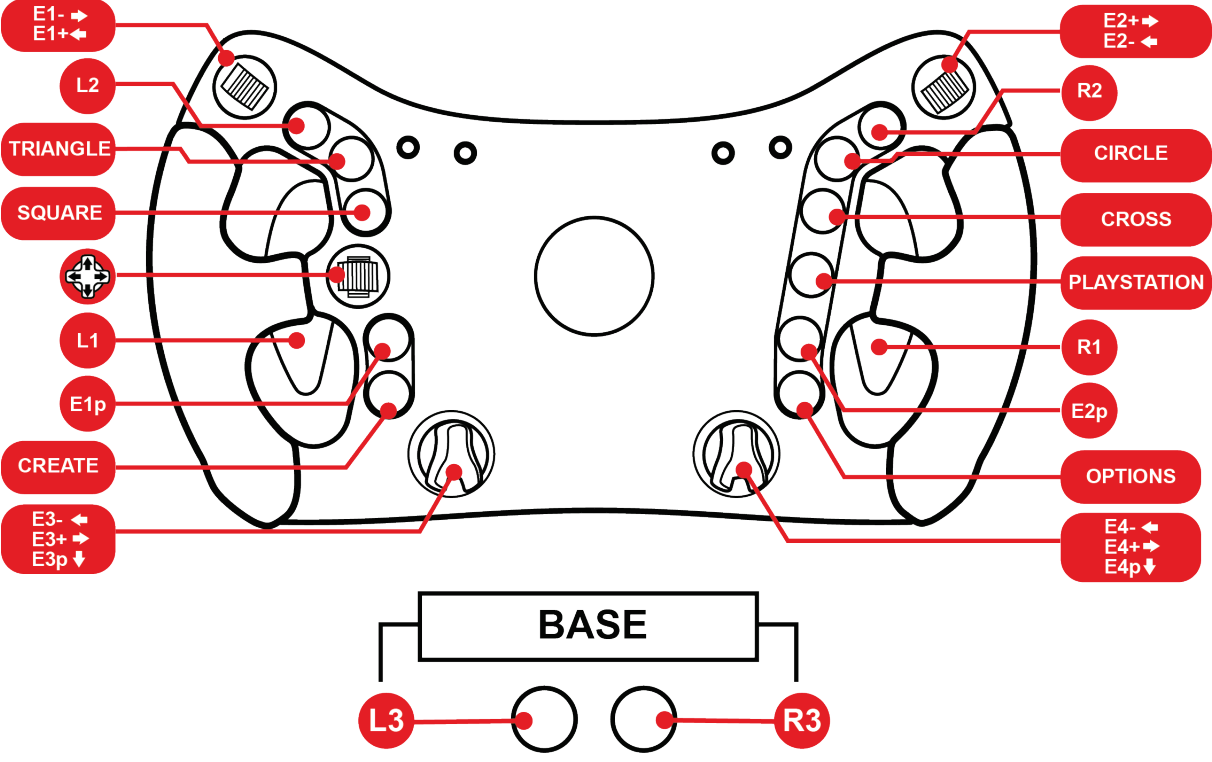



针对 Xbox Series/Xbox One 进行映射

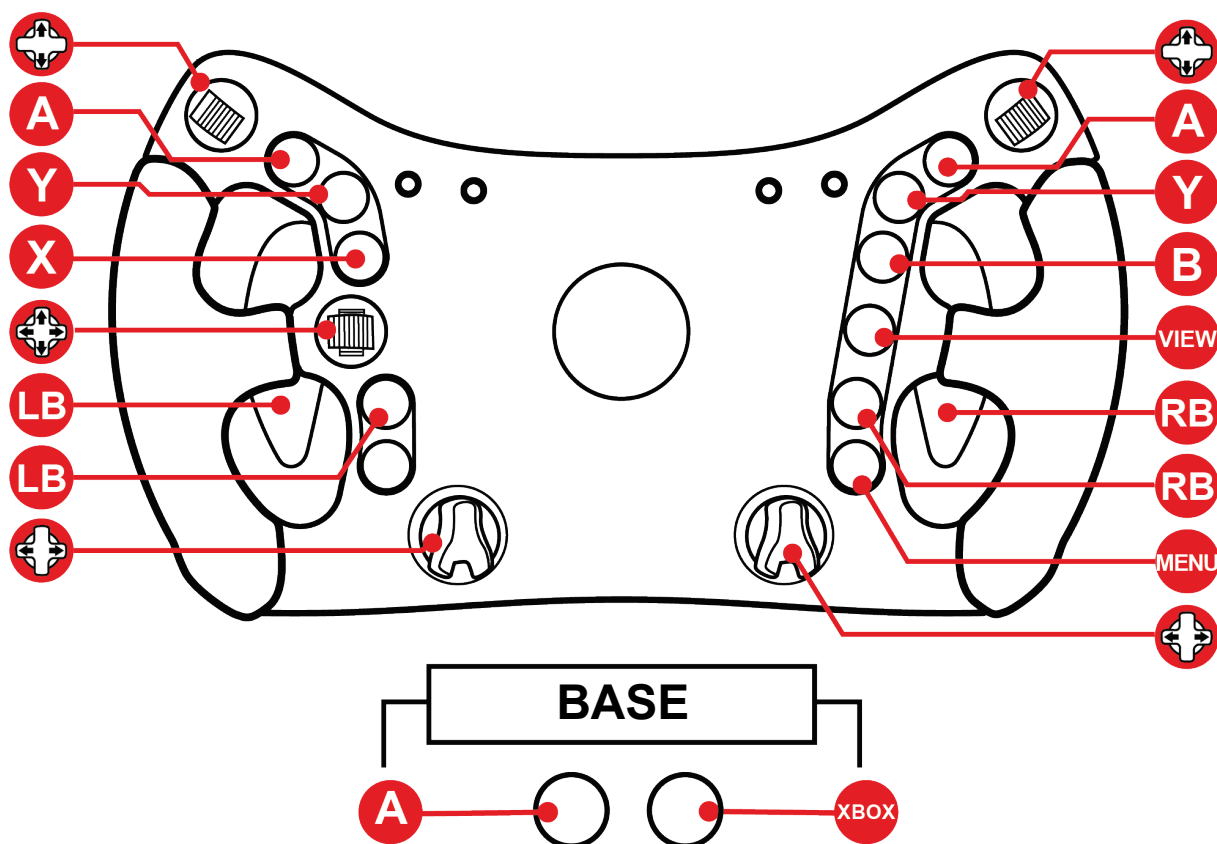

在 Xbox Series 和 Xbox One 上：

- 由于游戏主机协议的限制，Ferrari 488 GT3 Wheel Add-On 上的 LED 无法正常工作。
- 某些功能（编码器、操作按钮数）受游戏主机协议的限制。



6. LED 的运行

Ferrari 488 GT3 Wheel Add-On 通过 LED 显示比赛数据：旗帜、检修区和转速 (RPM)。

您可根据所使用的模式（GT3 或 Formula）来定制所显示的数据（LED 转速指示灯的亮度和颜色）。

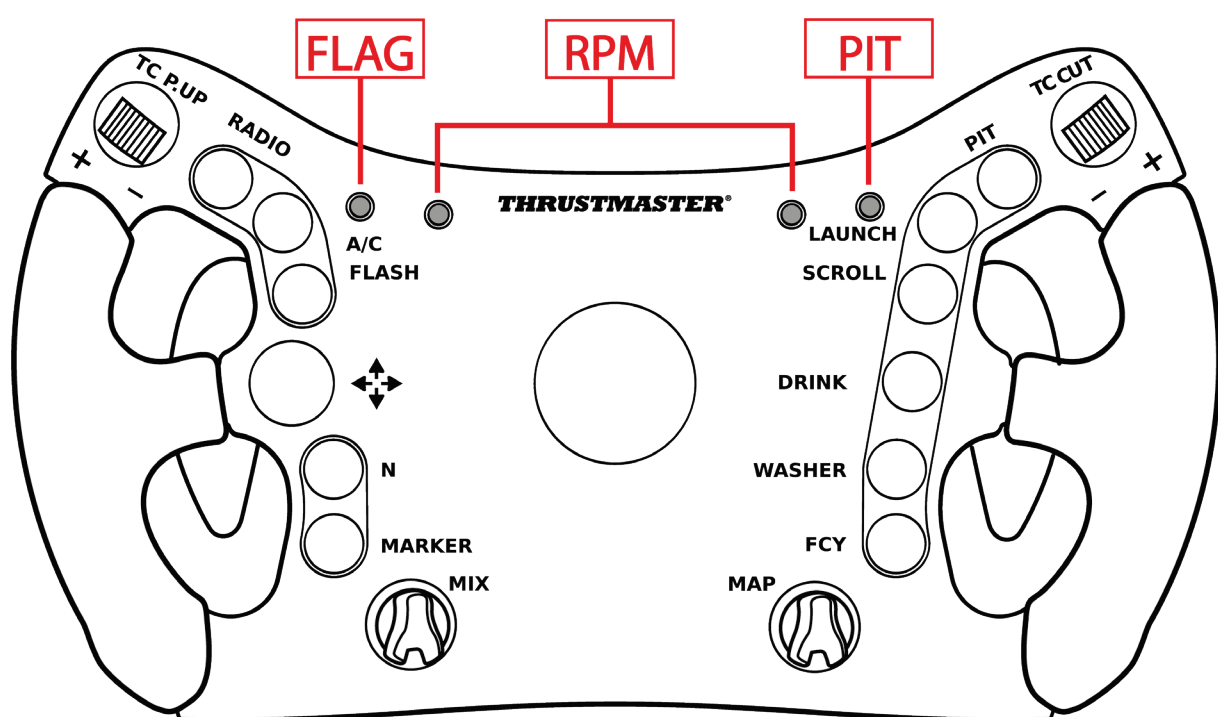

这些 LED 在 PC 和 PS4™/PS5™ 上均可正常运行。

在 Xbox Series 和 Xbox One 上，由于游戏主机协议的限制，这些 LED 无法正常工作。



如何进入退出 LED 菜单

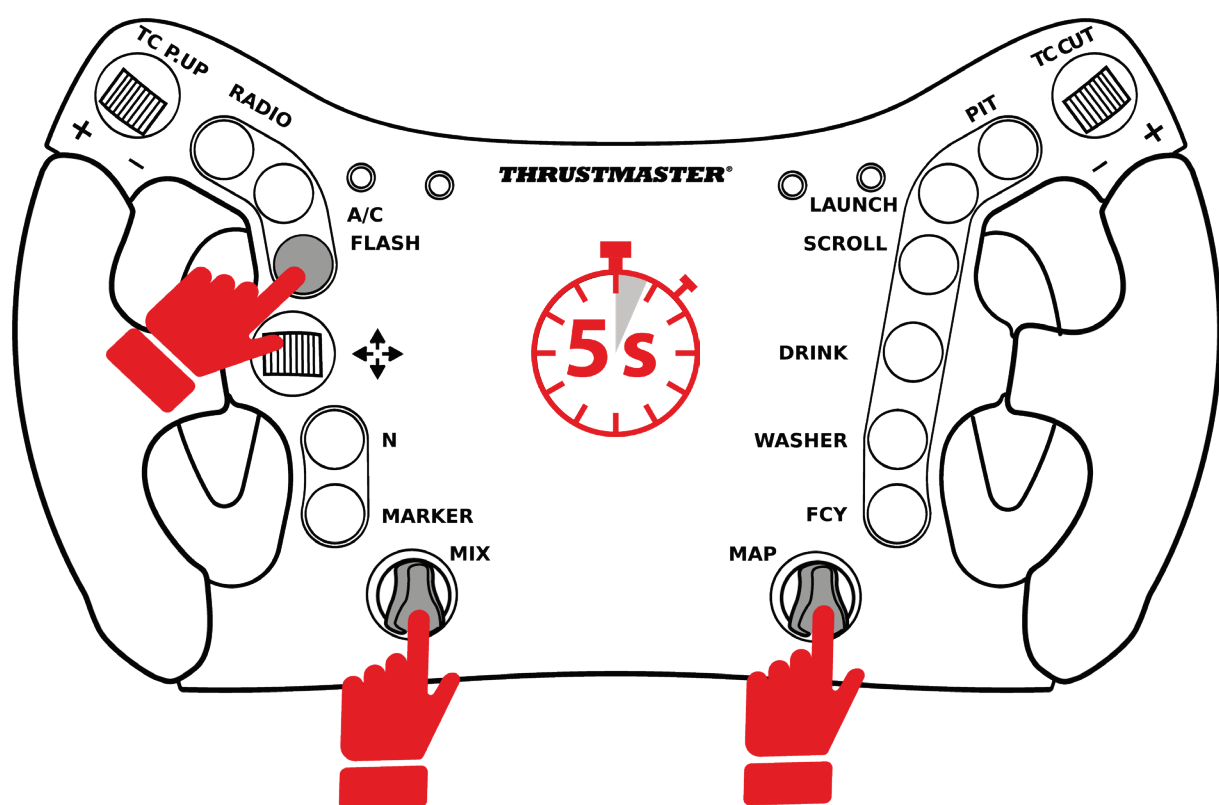

- 要进入 LED 菜单，请同时按 **FLASH** 按钮和两个旋转编码器并保持 **5 秒钟**，然后松开它们。
- 要退出 LED 菜单，请同时按 **FLASH** 按钮和两个旋转编码器，然后松开它们。



FLAG

RPM

PIT

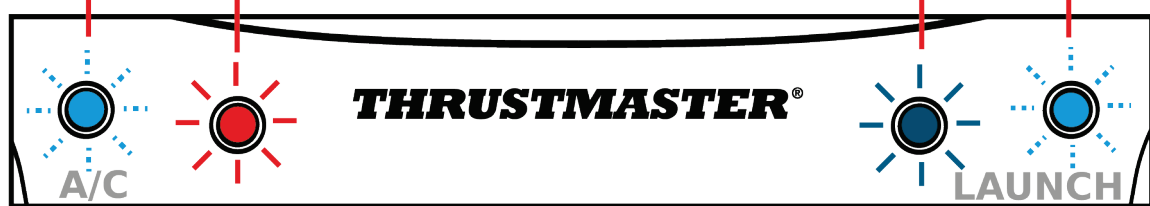

进入 **LED** 菜单：FLAG 和 PIT LED 以及 RPM LED 之一（左侧红色 LED 或右侧蓝色 LED）会点亮。



退出 **LED** 菜单：所有四个 LED 均会关闭。



如何调节 LED 亮度

- 通过同时按 **FLASH** 按钮和两个**旋转编码器**并保持 **5 秒**钟，然后松开它们，进入 LED 菜单。
- 向左转动左**编码器 (MIX)** 可降低亮度，向右转动可提高亮度。

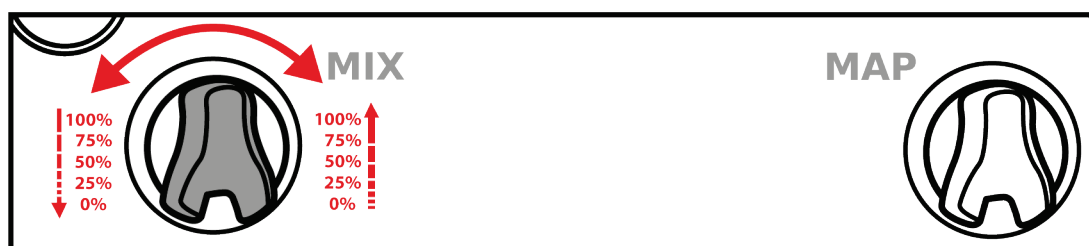

- 通过同时按 **FLASH** 按钮和两个**旋转编码器**，然后松开它们，退出 LED 菜单。



如何更改 LED 模式: GT3 或 Formula

- 通过同时按 **FLASH** 按钮和两个旋转编码器并保持 5 秒钟，然后松开它们，进入 LED 菜单。
- 向左转动右编码器 (**MAP**) 以选择 GT3 模式（红色 LED）或向右转动以选择 Formula 模式（蓝色 LED）。



GT3 模式（默认模式）



FORMULA 模式

- 通过同时按 **FLASH** 按钮和两个旋转编码器，然后松开它们，退出 LED 菜单。



7. 定制换挡拨片

您可调节 **Ferrari 488 GT3 Wheel Add-On** 换挡拨片的间距和行程范围。

间距是指调整换挡拨片的宽度，这会改变把手与换挡拨片之间的距离。

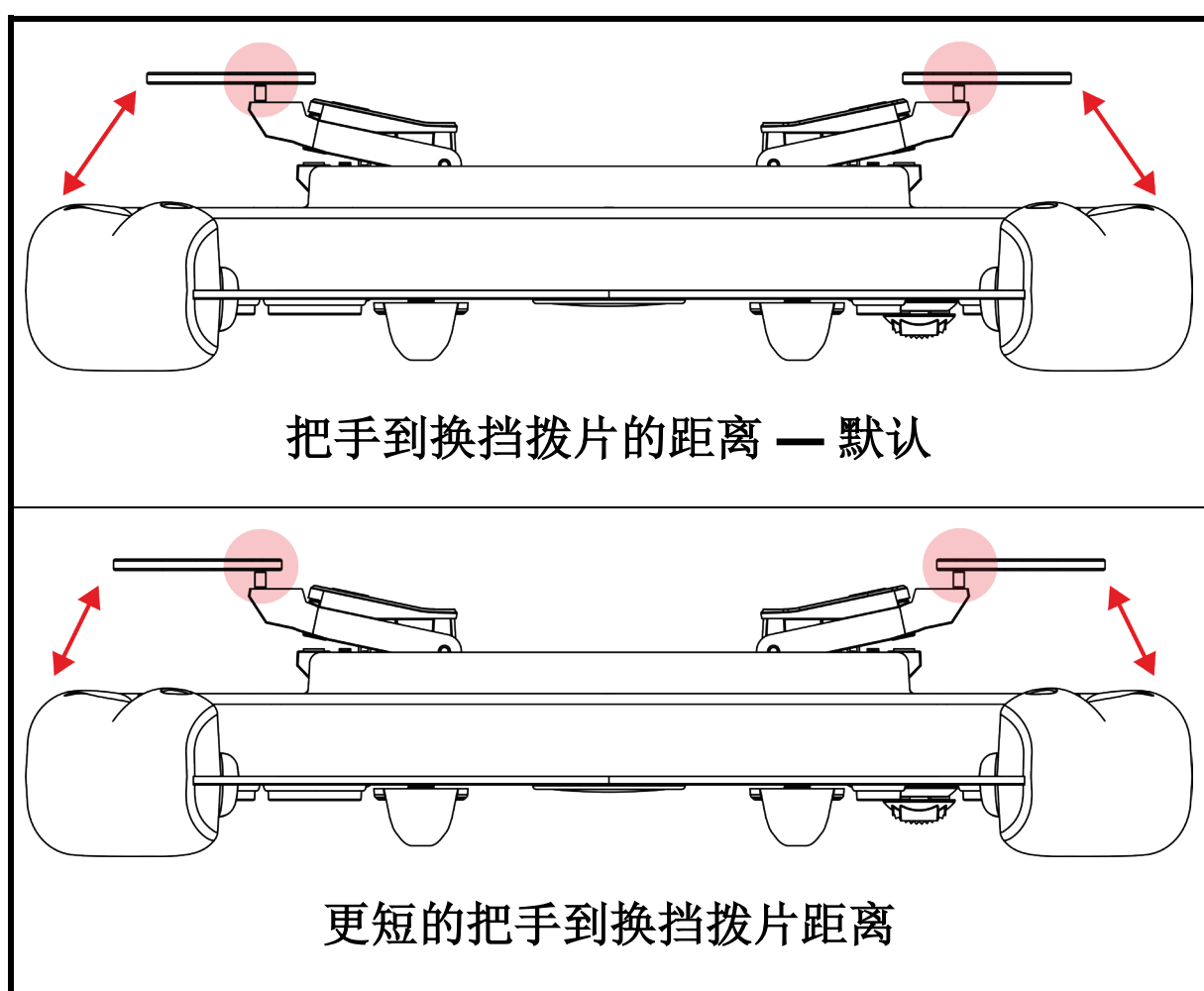



使用隔垫来调整行程范围会改变换挡拨片的激活距离。

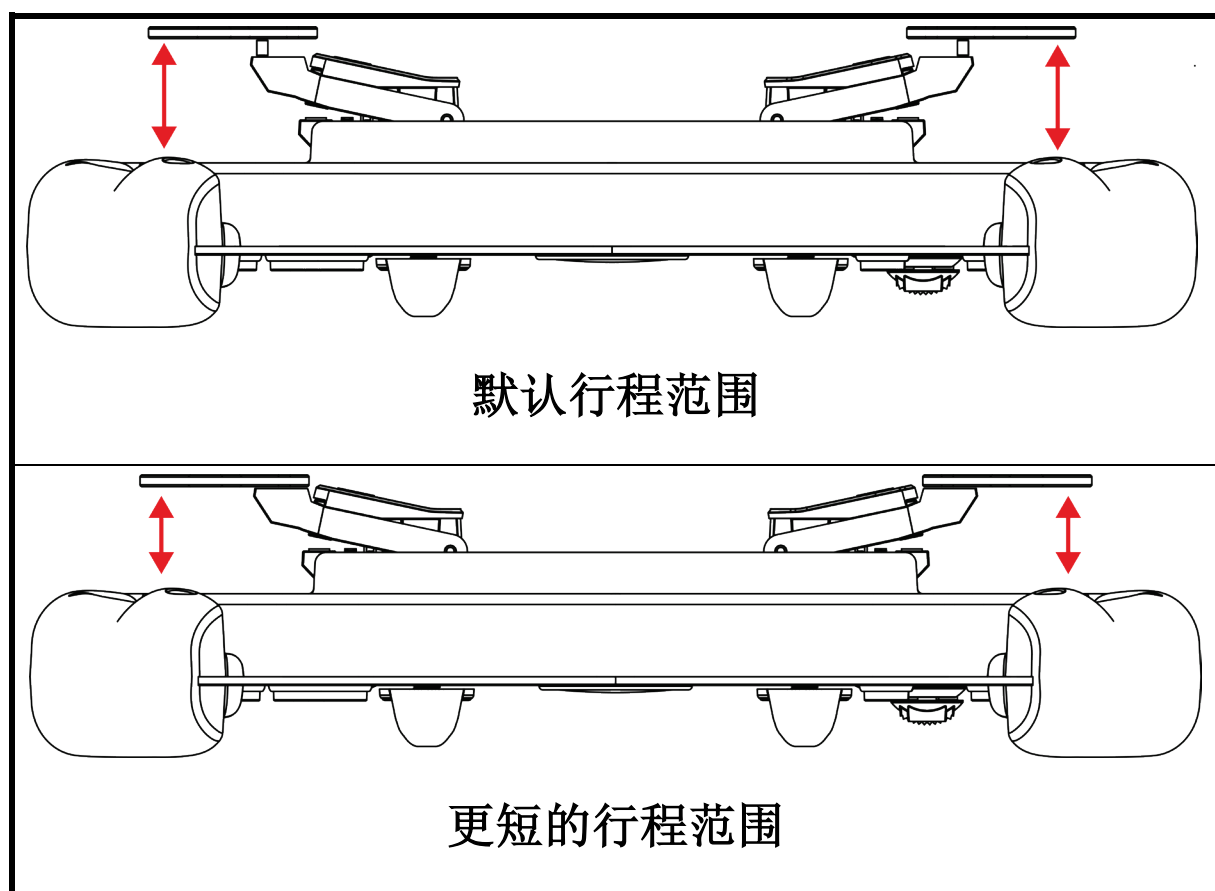

您还可以使用随附的垫片组来调整**磁性灵敏度**和换挡拨片的音量。

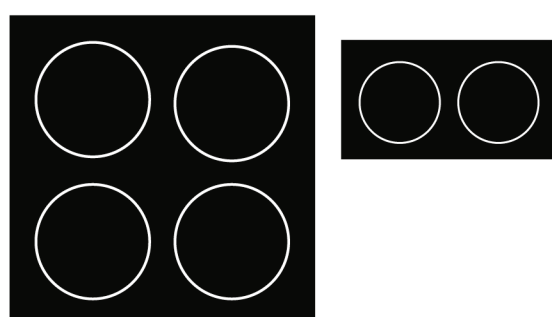



如何调整换挡拨片的间距

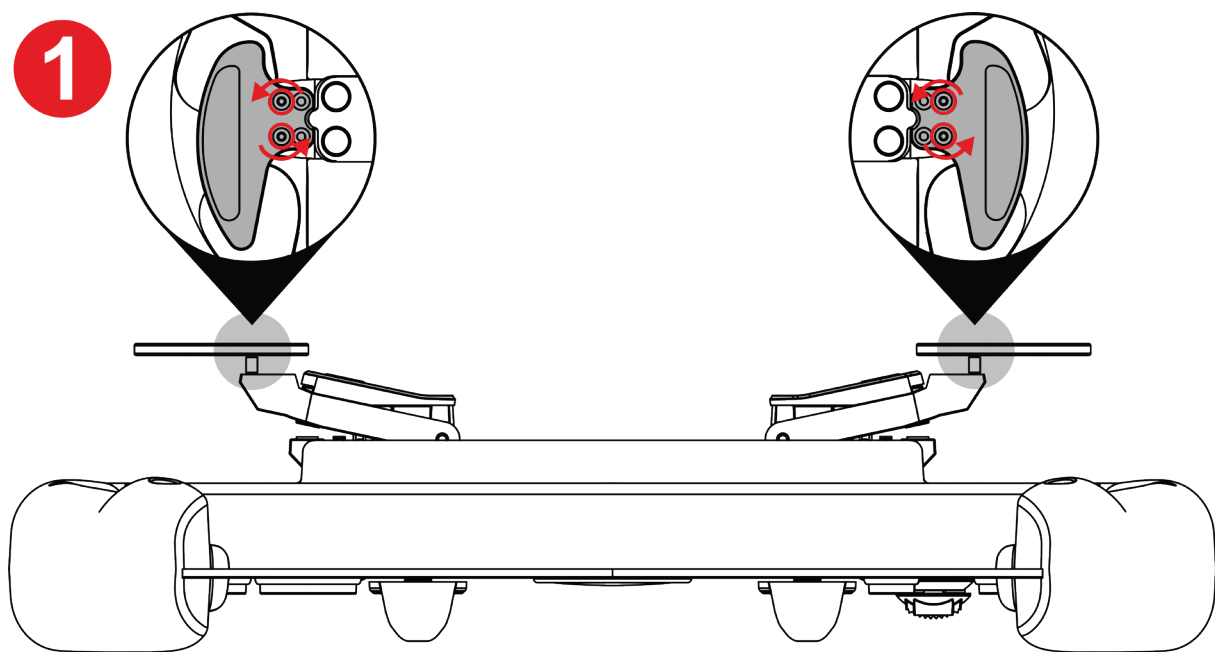

1 使用随附的梅花扳手拧松换挡拨片的四个螺丝。

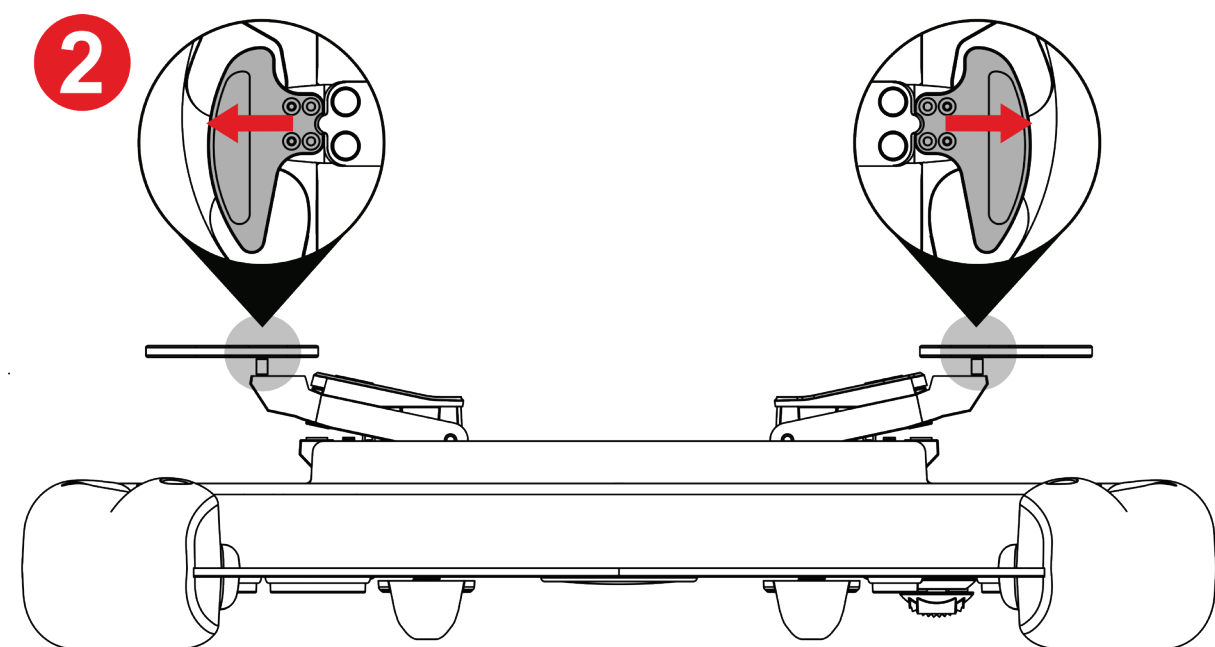

2 将换挡拨片朝外放置，对准螺孔。

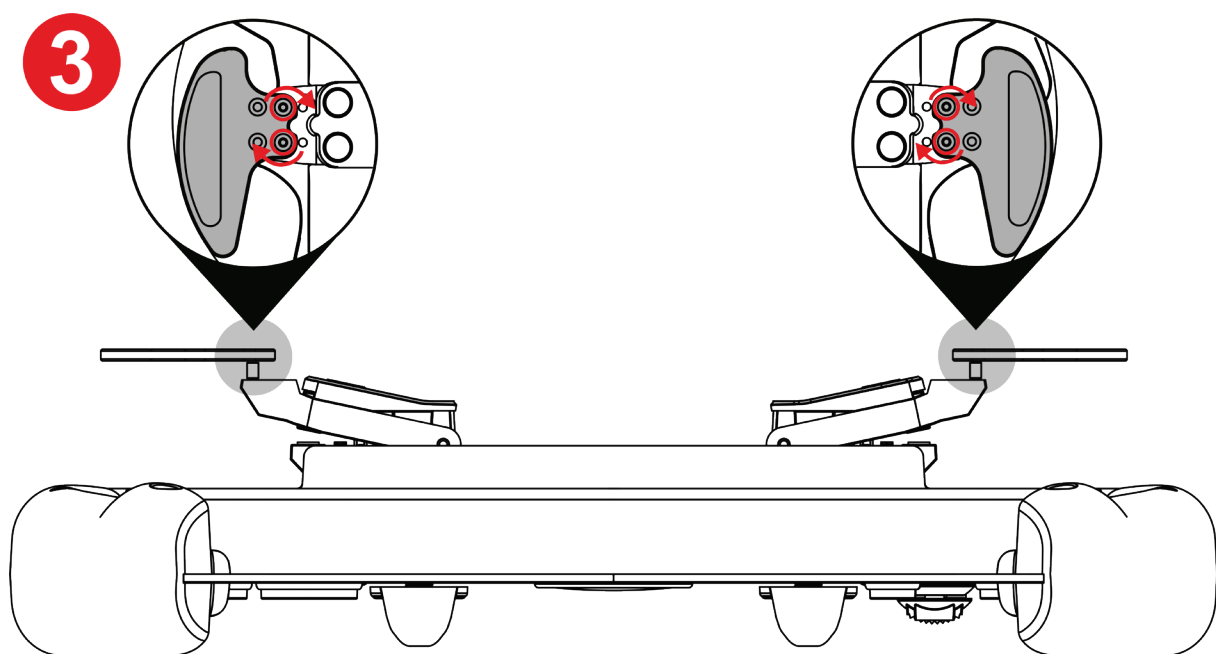

3 使用随附的梅花扳手拧紧换挡拨片的四个螺丝。



如何调整换挡拨片的行程范围

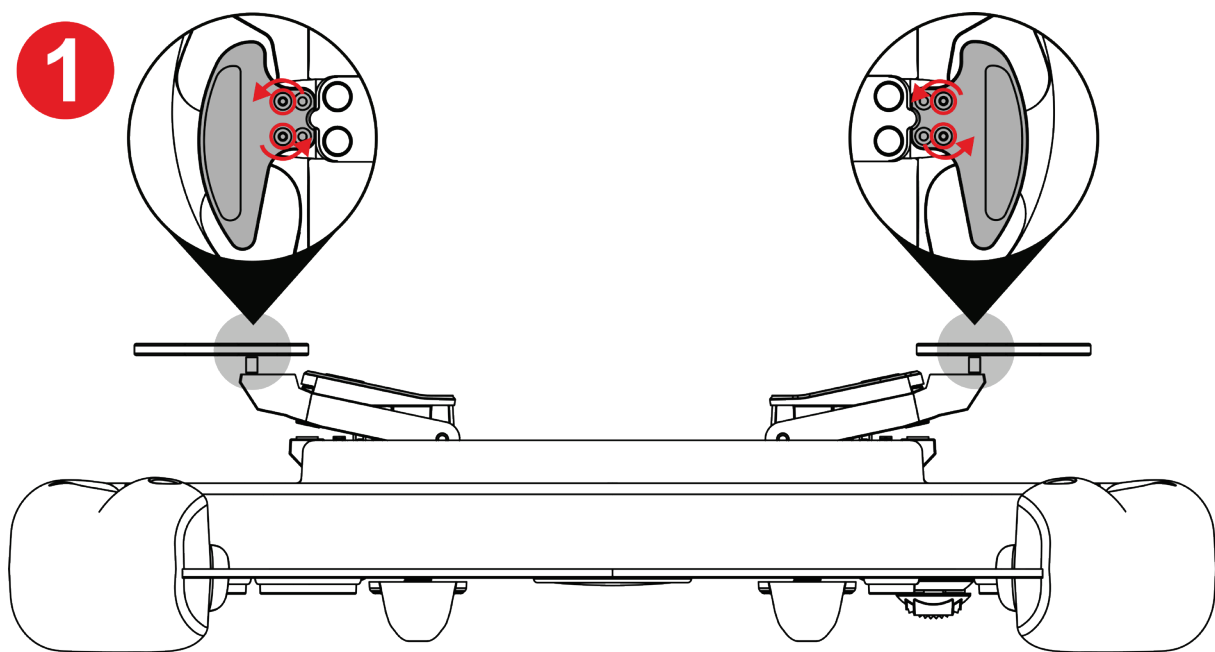

1 使用随附的梅花扳手拧松换挡拨片的四个螺丝。

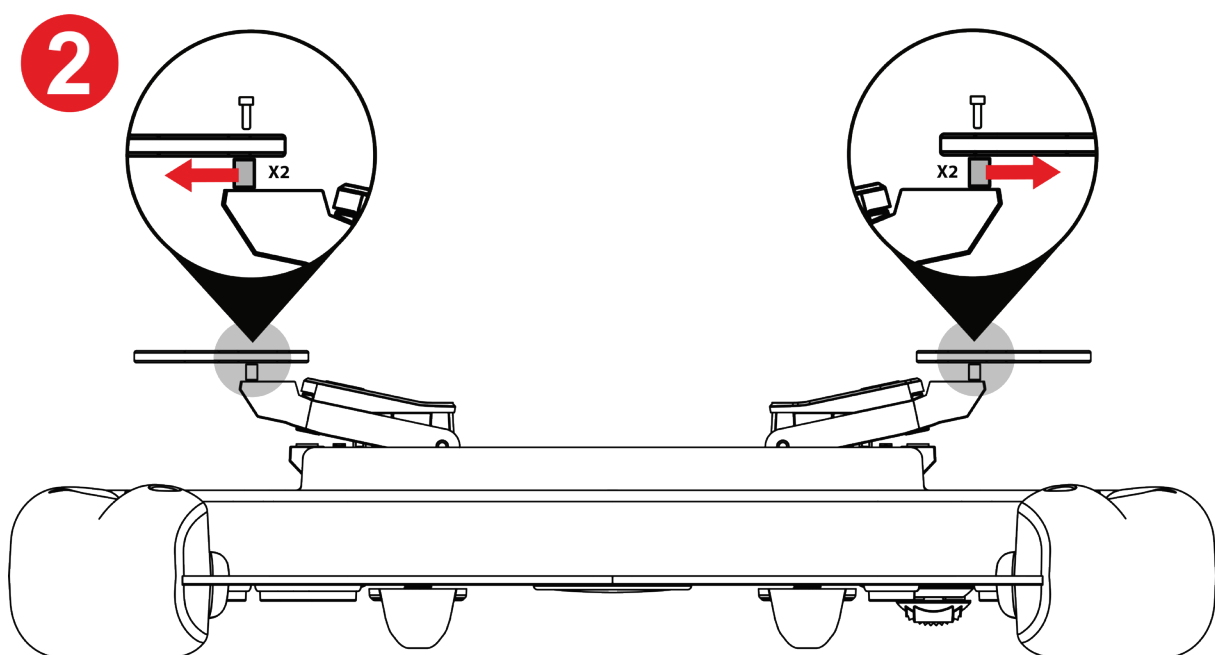

2 取下隔垫。

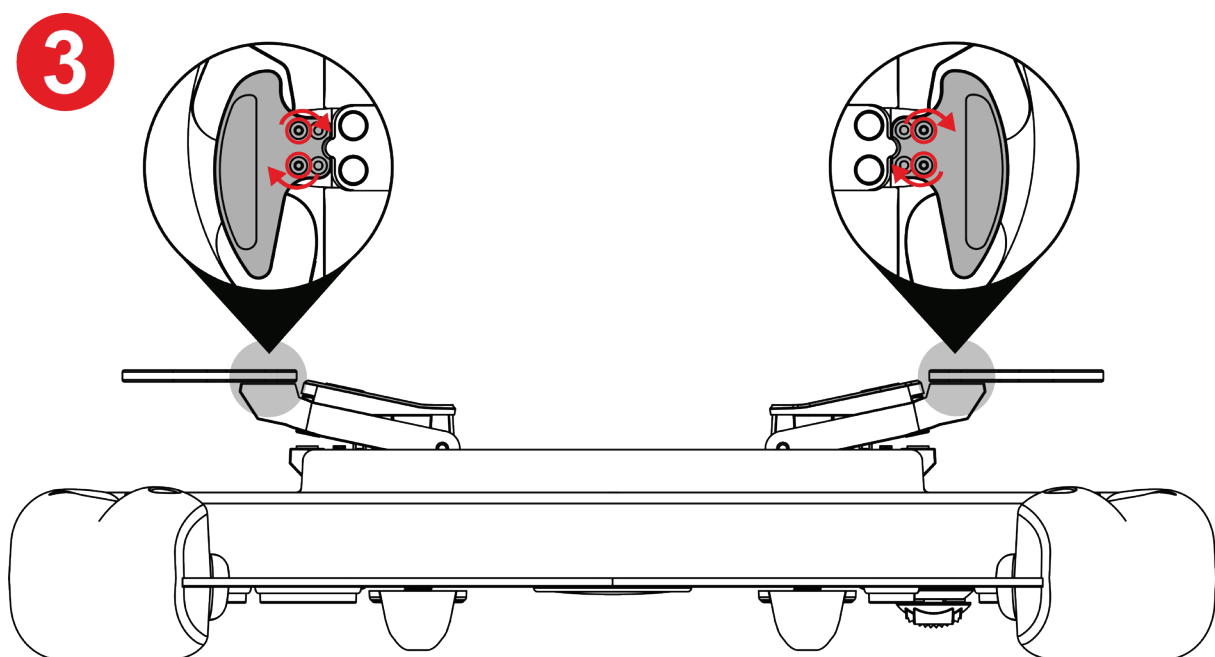

3 使用随附的梅花扳手拧紧换挡拨片的四个螺丝。



如何调整磁性灵敏度和换挡拨片的音量

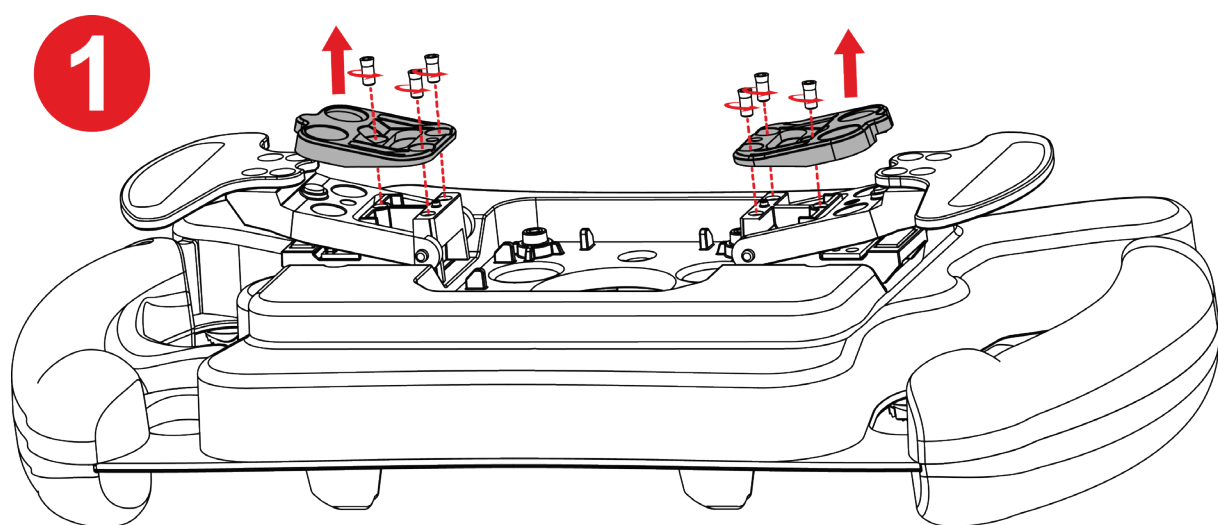

❶ 通过使用随附的梅花扳手拧松六个止动螺丝，取下磁性限位器。

❷

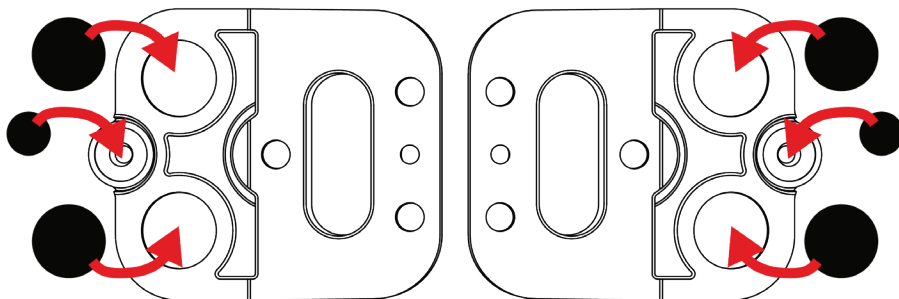
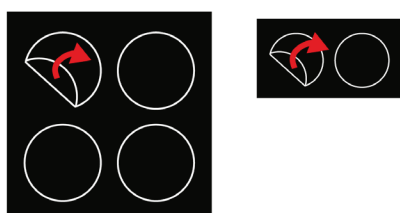

❷ 撕下提供的垫片，并将其贴到磁性限位器下方的适当位置。



有关可能的配置及其作用，请参阅**磁性灵敏度和缓动盘音量衰减表**





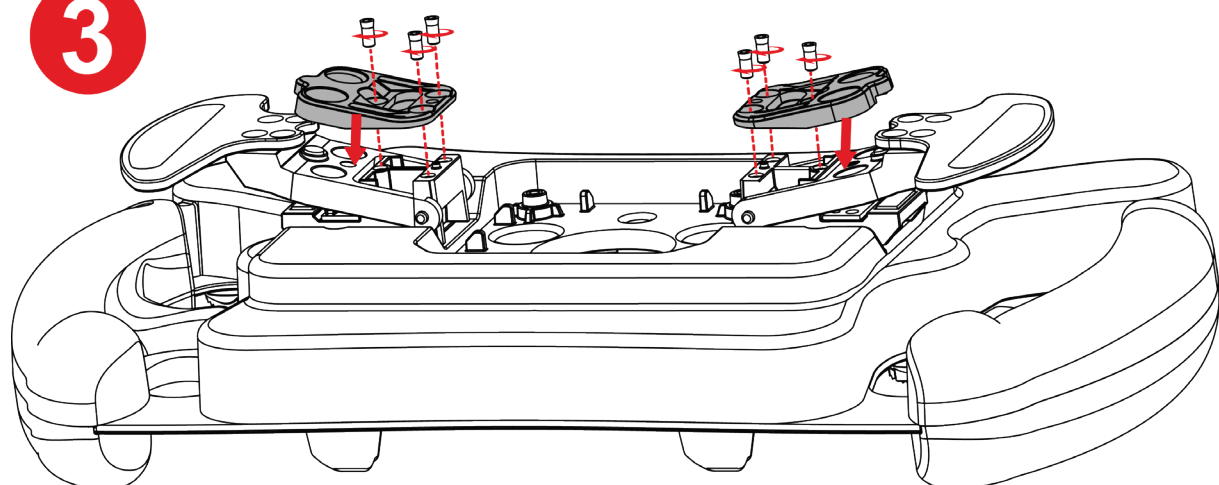

3

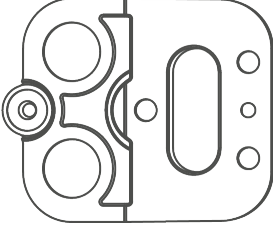
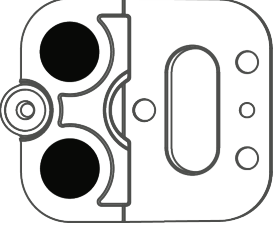
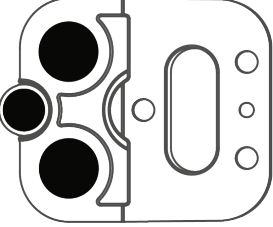

③ 通过使用随附的梅花扳手拧紧六个止动螺丝，重新安装磁性限位器。

磁性灵敏度和缓动盘音量衰减表

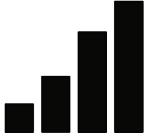
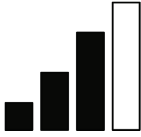
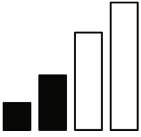
	 (默认)		
磁性灵敏度			
音量			



8. 常见问题解答和技术支持

您对 Ferrari 488 GT3 Wheel Add-On 是否有任何疑问，或者您是否遇到任何技术问题？若有的话，请访问 Thrustmaster（图马思特）技术支持网站：

<http://support.thrustmaster.cn/zh/product/ferrarif488gt3addon-zh>

在此页面中，您还可以更新方向盘的固件。



THRUSTMASTER®

FERRARI 488 GT3 WHEEL ADD-ON

PC (Windows 10/11)

PS4™ / PS5™

Xbox Series / Xbox One

使用者手冊



在安裝本產品之前、以任何方式使用本產品之前以及對其執行任何維護之前，請仔細閱讀本手冊提供的說明。請務必遵守安全說明。不遵守這些說明可能導致事故和/或損壞。請保留本手冊，以便您日後查閱說明。

目錄

1.	包裝清單	5
2.	特性	6
3.	有關方向盤使用的資訊	8
4.	安裝快拆支架	13
	安裝適用於閃鎖式底座的快拆支架	14
	安裝適用於螺紋式底座的快拆支架	17
5.	對應	21
	針對 PC 進行對應	21
	針對 PS4™/PS5™ 進行對應	22
	針對 Xbox Series/Xbox One 進行對應	23
6.	LED 的運作	24
	如何進入/退出 LED 菜單	25
	如何調節 LED 亮度	27
	如何變更 LED 模式： GT3 或 Formula	28

7.	自訂換擋撥片	29
	<i>如何調整換擋撥片的間距.....</i>	31
	<i>如何調整換擋撥片的行程範圍.....</i>	33
	<i>如何調整磁性敏感度和換擋撥片的音量.....</i>	35
8.	常見問題解答和技術支援.....	37



FERRARI 488 GT3 WHEEL ADD-ON

借助 Ferrari 488 GT3 Wheel Add-On 加入傳奇的 GT 賽車，該產品是一款專為效能而設計的方向盤，相容於所有 Thrustmaster（圖馬思特）方向盤底座。

本手冊將輔助您安裝 Ferrari 488 GT3 Wheel Add-On 並讓其運作在最佳條件下。在開始賽車之前，請仔細閱讀說明和警告：它們將說明您盡情享受您的產品。



1. 包裝清單

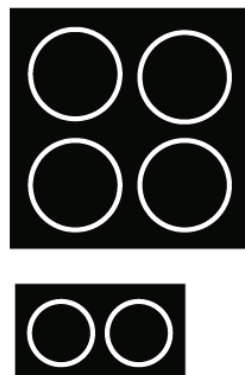
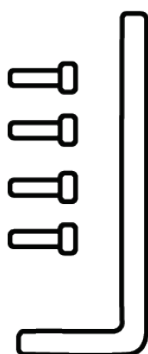
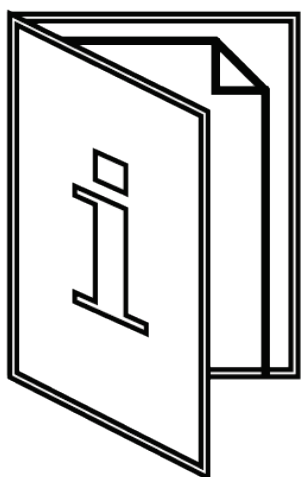
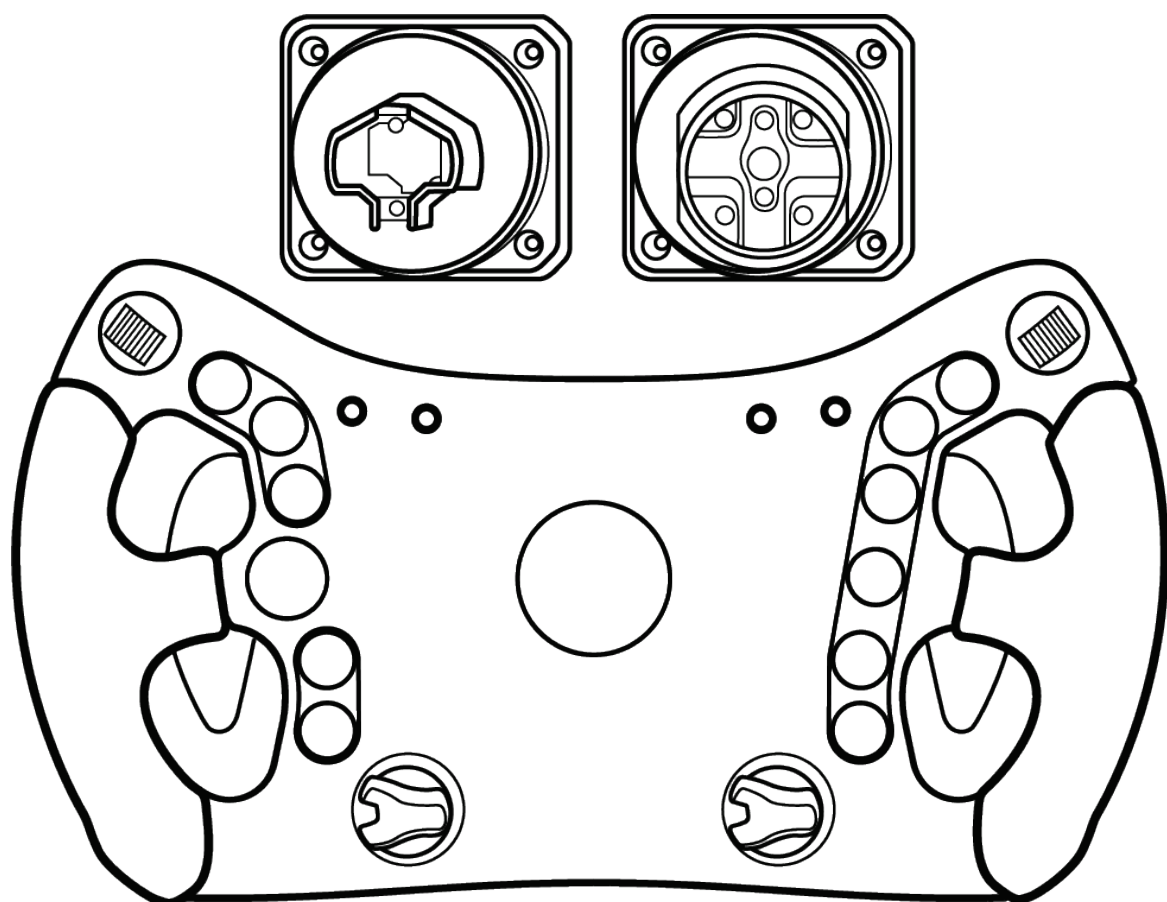



2. 特性

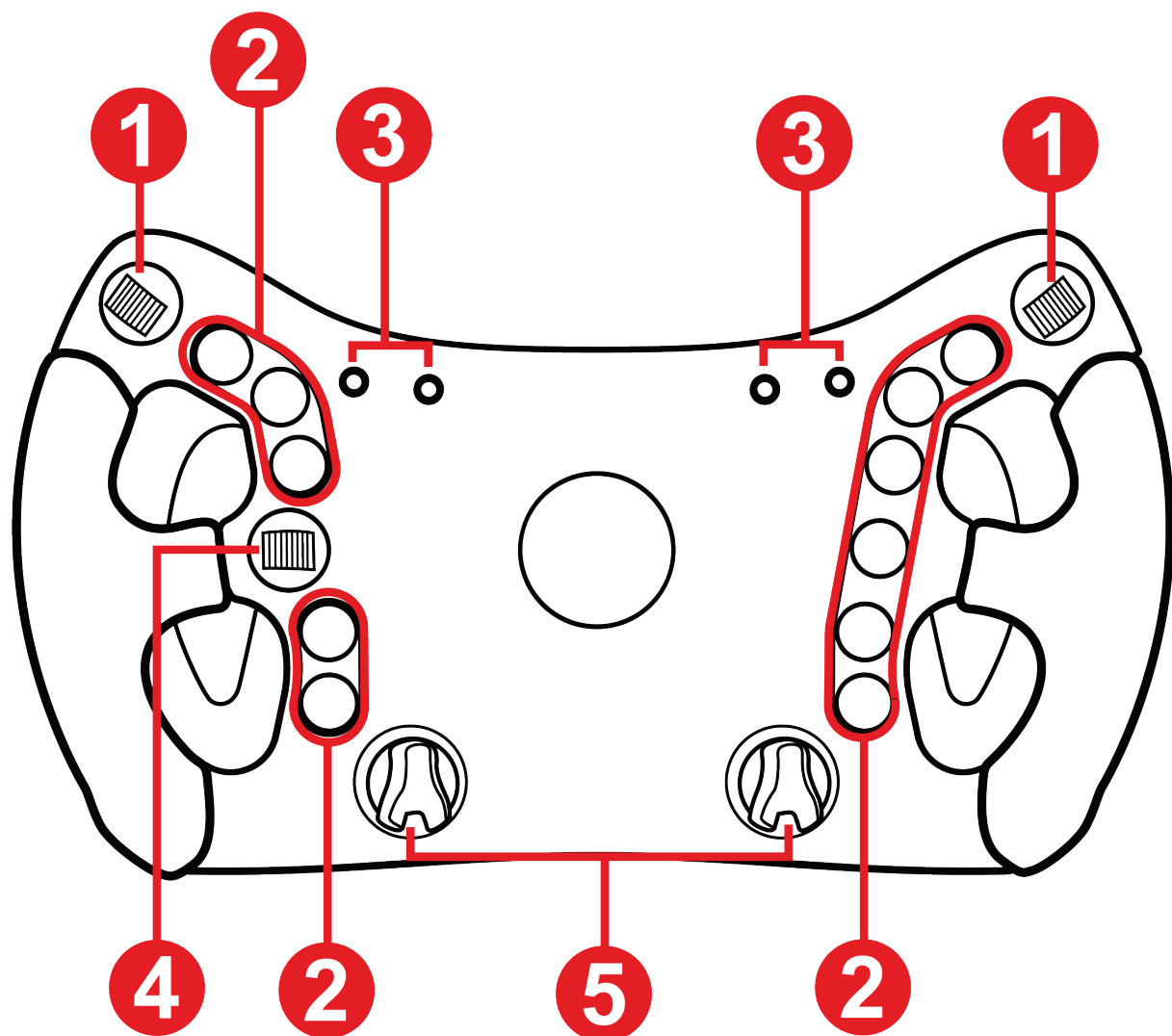

- ❶ 拇指編碼器
- ❷ 11 個操作按鈕
- ❸ RPM LED 和賽車資料（旗幟、檢修區）
- ❹ D-pad 方向鍵
- ❺ 旋轉編碼器

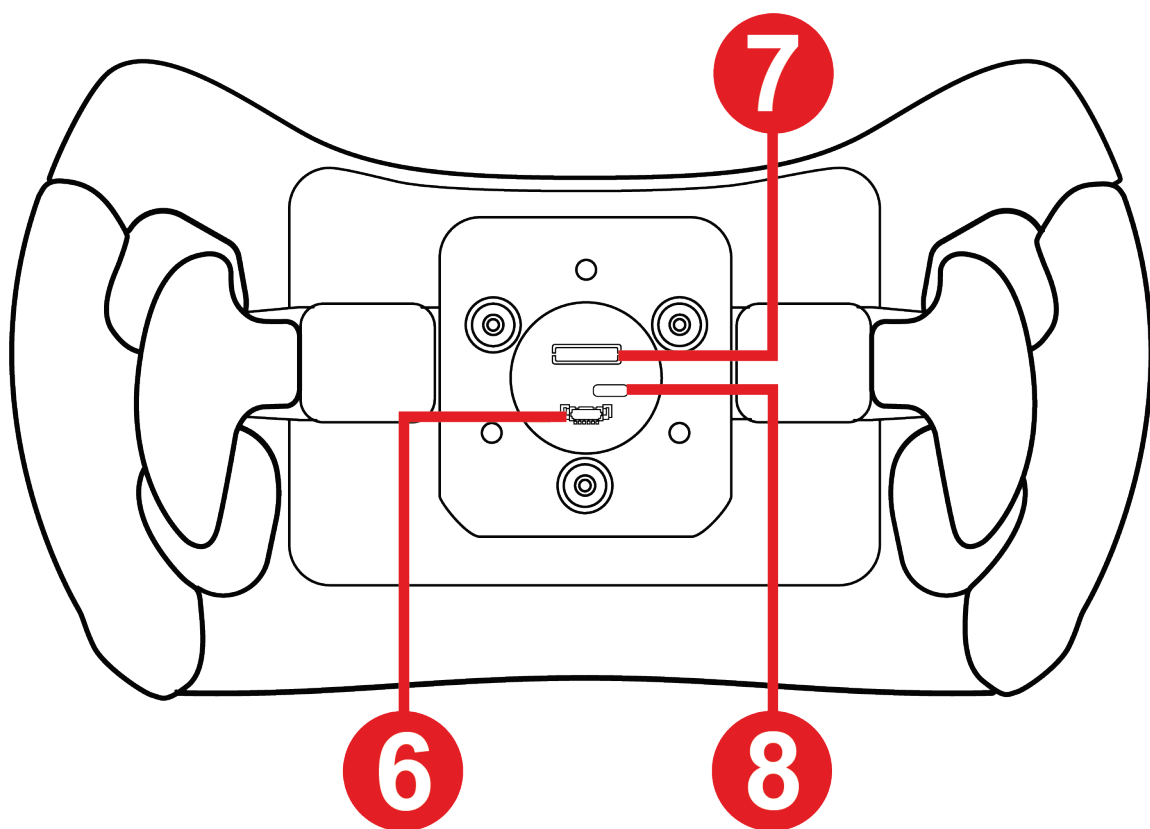

- ⑥ 連接埠，用於連接適用於螺紋式底座的快拆支架
- ⑦ 連接埠，用於連接適用於閃鎖式底座的快拆支架
- ⑧ USB-C 埠（需要韌體更新時使用 — 不隨附連接線）

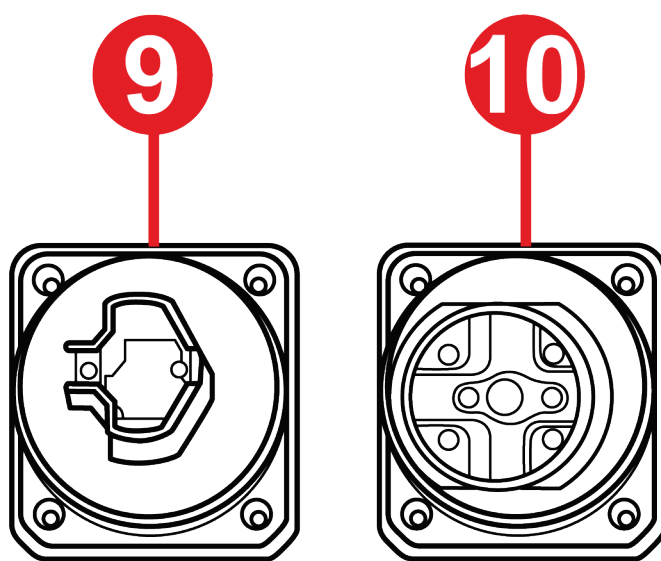

- ⑨ 適用於閃鎖式底座的快拆支架
- ⑩ 適用於螺紋式底座的快拆支架



3. 有關方向盤使用的資訊



文件

在使用本產品之前，請仔細重讀本文件，並妥善儲存以備日後參考。



觸電

- 請將本產品置於乾燥的位置，切勿將其暴露在灰塵或陽光中。
- 切勿扭曲或拉扯接頭和連接線。
- 按照所示連接方向連接各個元件。
- 切勿讓任何液體濺到本產品或其接頭上。
- 切勿造成本產品短路。
- 切勿拆解本產品（本手冊中另有規定的情形除外）；切勿將其投入火中，亦勿將其暴露在高溫環境中。
- 切勿拆開本裝置：內部沒有任何可由使用者維修的零部件。任何維修工作均須由製造商、指定代理程式商或持證技工執行。



保護遊戲區的安全

- 請勿在遊戲區內放置任何可能擾亂使用者練習的物體，或可能引起不適當的動作或被他人打斷的物體（例如咖啡杯、電話、鑰匙）。
- 請勿用地毯、小地毯、毛毯、覆蓋物或任何其他物品覆蓋電源線，也不要將電源線佈設在有人走動的地方。



因力回饋和重複運動造成的傷害

使用力回饋方向盤可能會造成肌肉或關節疼痛。為避免這些問題：

- 事先進行熱身，並避免長時間的練習。
- 每練習一小時後休息 10 到 15 分鐘。
- 如果手、手腕、手臂、腳或腿有任何疲勞或疼痛的感覺，請按下關閉力回饋按鈕，關閉底座，休息幾小時後再復原練習。
- 如果復原練習時仍然存在上述症狀或疼痛感，應停止練習並就醫。
- 請勿將力回饋強度設定為超出您的專業技能和身體狀況的水準。
- 請勿讓未滿 16 歲的人接觸本裝置。
- 務必按照本手冊的說明正確連接底座和方向盤。



發生不可預見的強力快速旋轉的風險：切勿將手或手臂穿過方向盤輪緣的開口，或放入方向盤的旋轉軌道上。

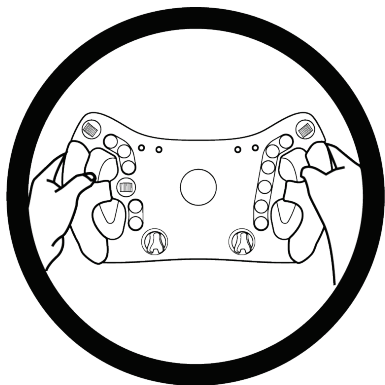

使用本產品時，應始終將雙手正確放在方向盤上，不得完全離開方向盤。



本產品只能由年滿 **16** 歲的使用者
操作。



4. 安裝快拆支架

Ferrari 488 GT3 Wheel Add-On 隨附兩個快拆支架，分別對應兩種不同類型的 Thrustmaster（圖馬思特）底座。

系統	相容性
 <p>適用於門鎖式底座的快拆 支架</p>	T818 、 T818 Ferrari SF1000 Simulator 以及未來的 Thrustmaster（圖馬思特）底座。
 <p>適用於螺紋式底座的快拆 支架</p>	T-GT / T-GT II Servo Base 、 T300 RS Servo Base 、 TS PC Racer 、 TS-XW 、 TX Racing Wheel Servo Base 、 TS-XW Servo Base 。



在每次使用前，請按照本手冊針對相應底座的說明確認 **Ferrari 488 GT3 Wheel Add-On** 仍然正確地固定到支架上。



安裝適用於閃鎖式底座的快拆支架

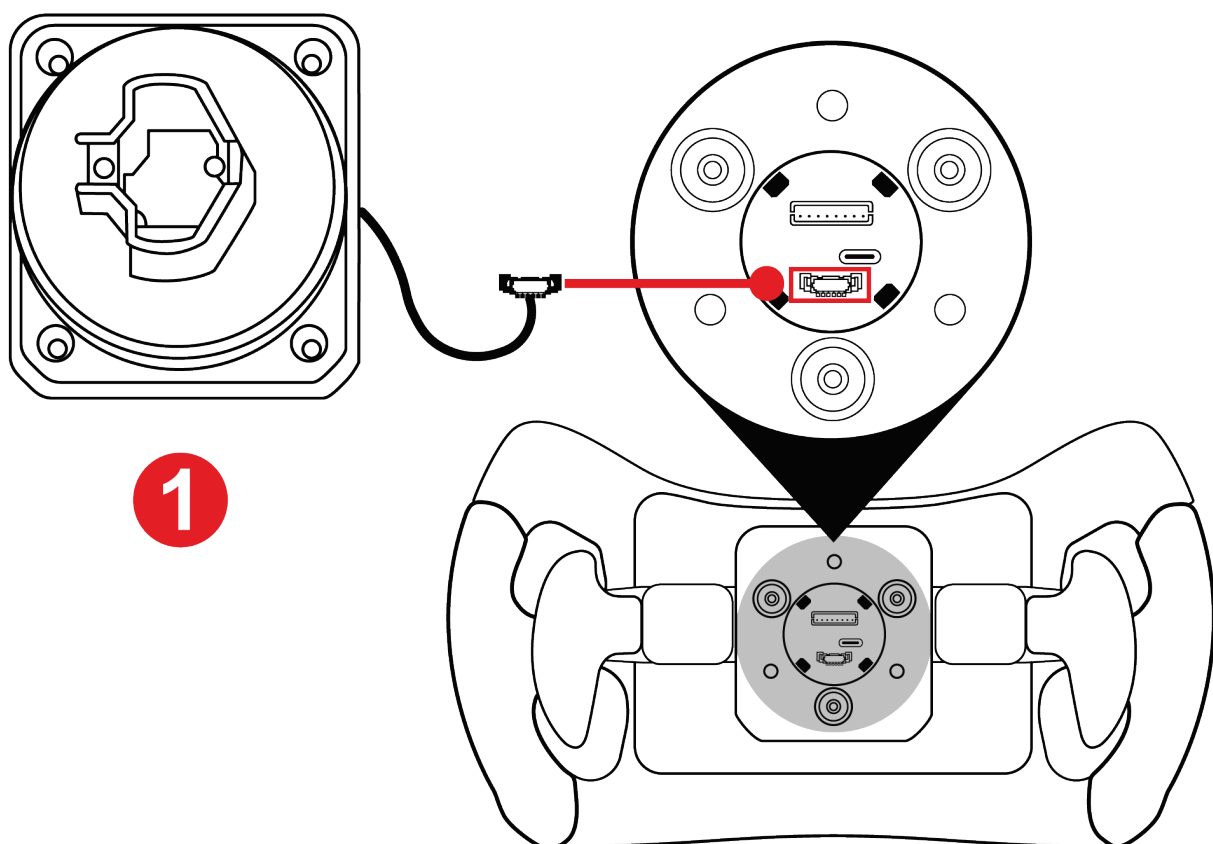

1

❶ 將快拆支架接頭插入到方向盤背部的相應埠中。



為避免夾傷連接線，請在旋緊固定支架之前，先將連接線收回到連接線保護套中。

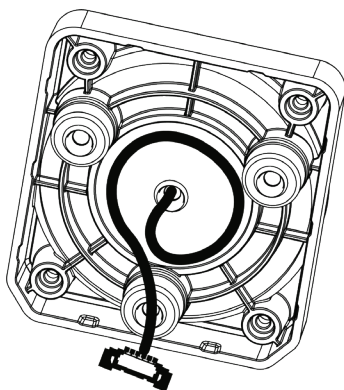

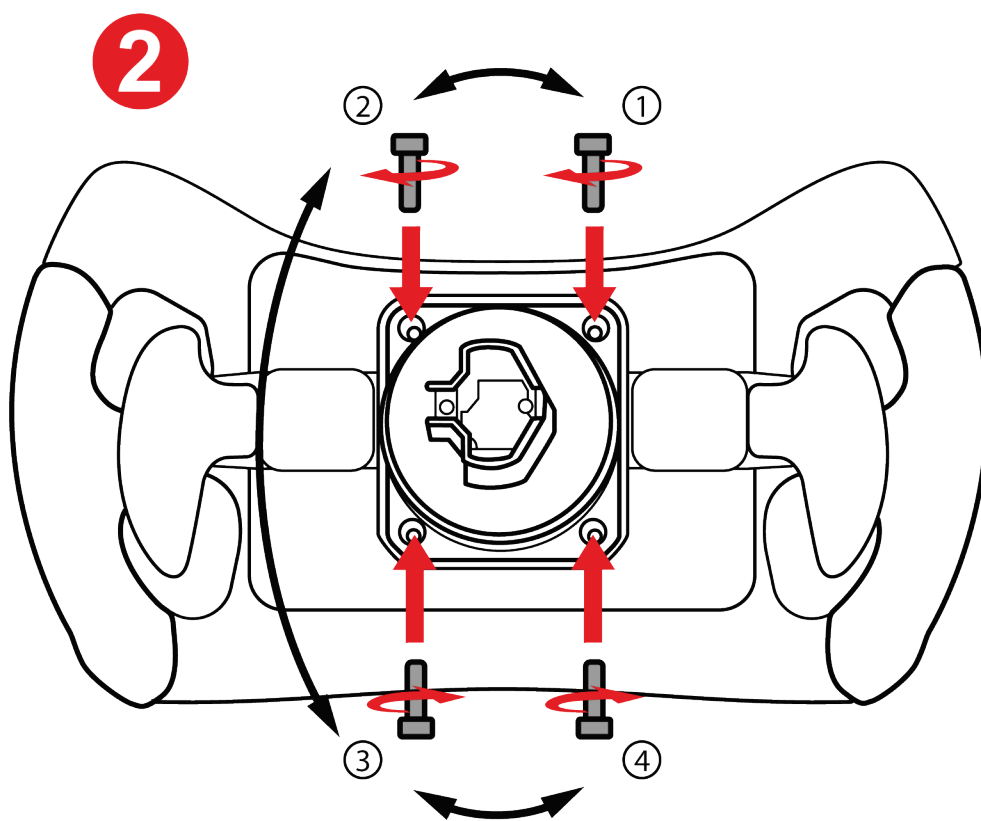

② 插入快拆支架並使用提供的梅花扳手擰緊支架。



在安裝支架時，切勿過度擰緊螺絲。

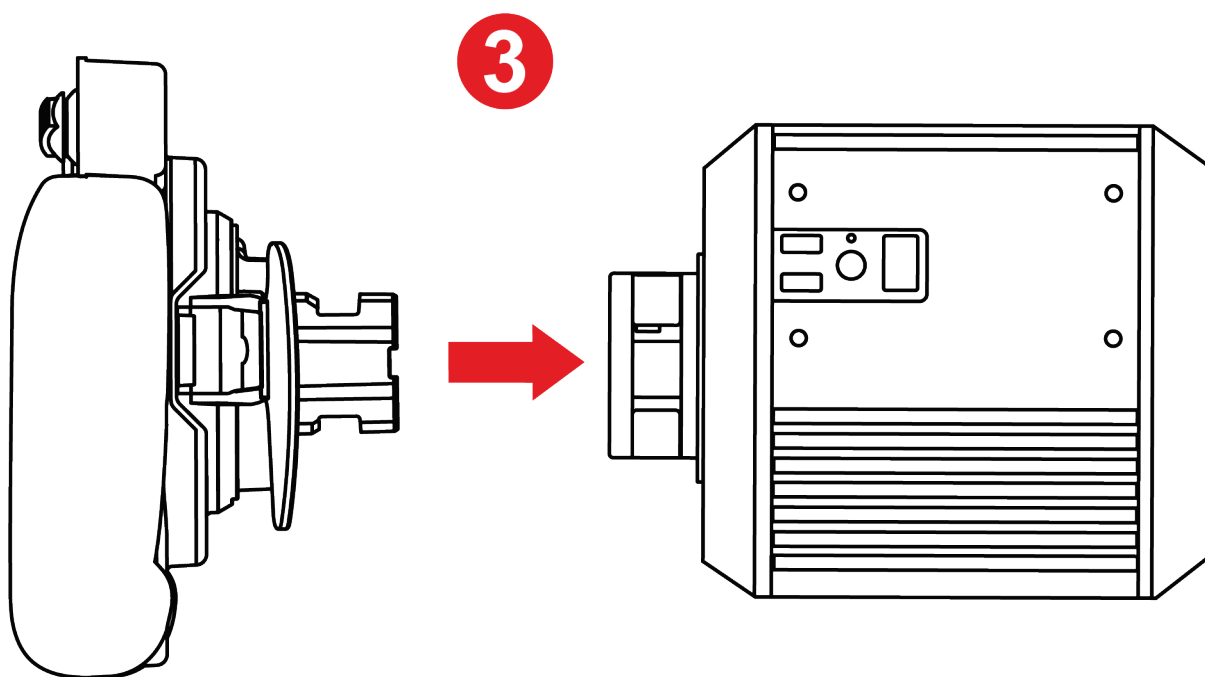

3 將方向盤安裝到底座中。



按照底座使用者手冊中規定的安裝程式操作。



安裝適用於螺紋式底座的快拆支架

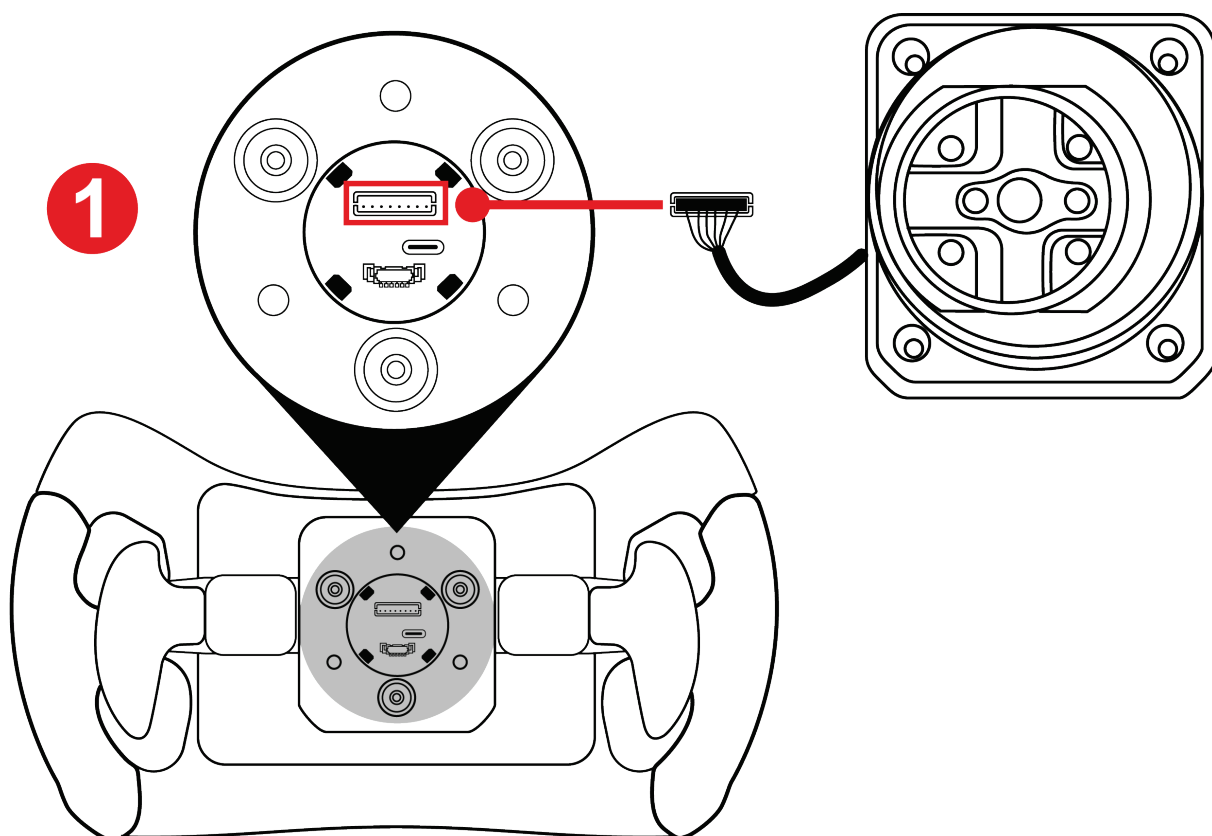

- 1 將快拆支架接頭插入到方向盤背部的相應埠中。



為避免夾傷連接線，請在旋緊固定支架之前，先將連接線收回到連接線保護套中。

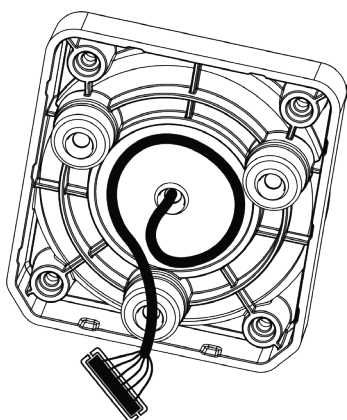

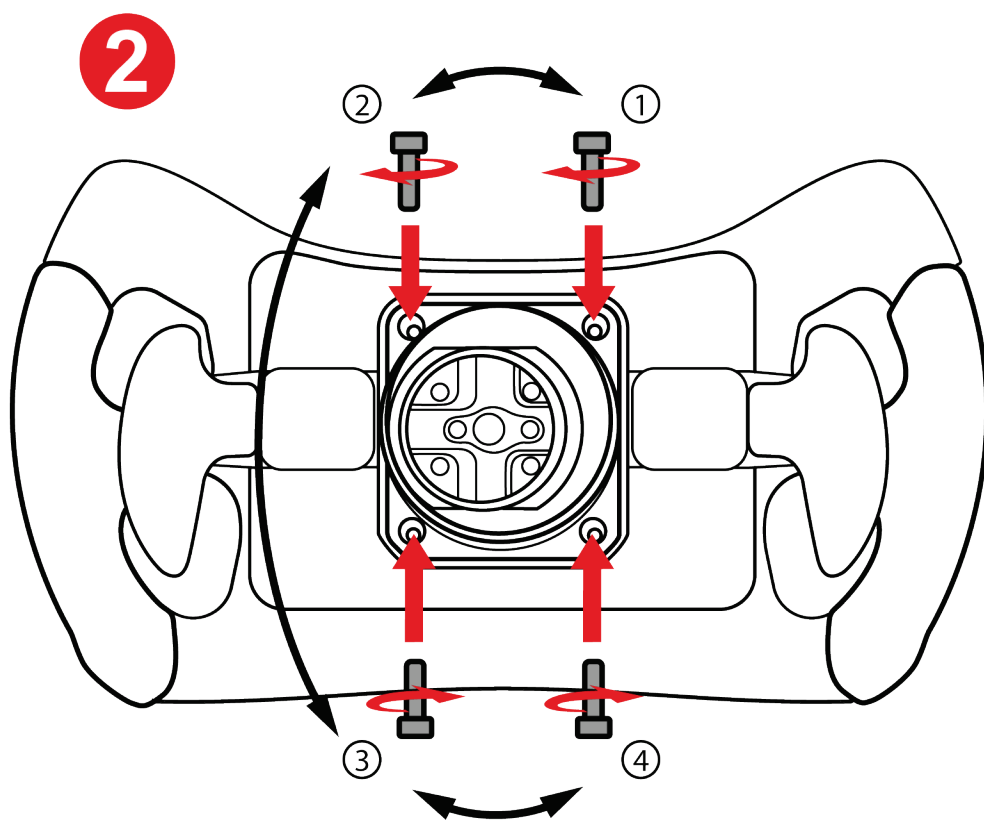

② 插入快拆支架並使用提供的梅花扳手擰緊支架。



在安裝支架時，切勿過度擰緊螺絲。

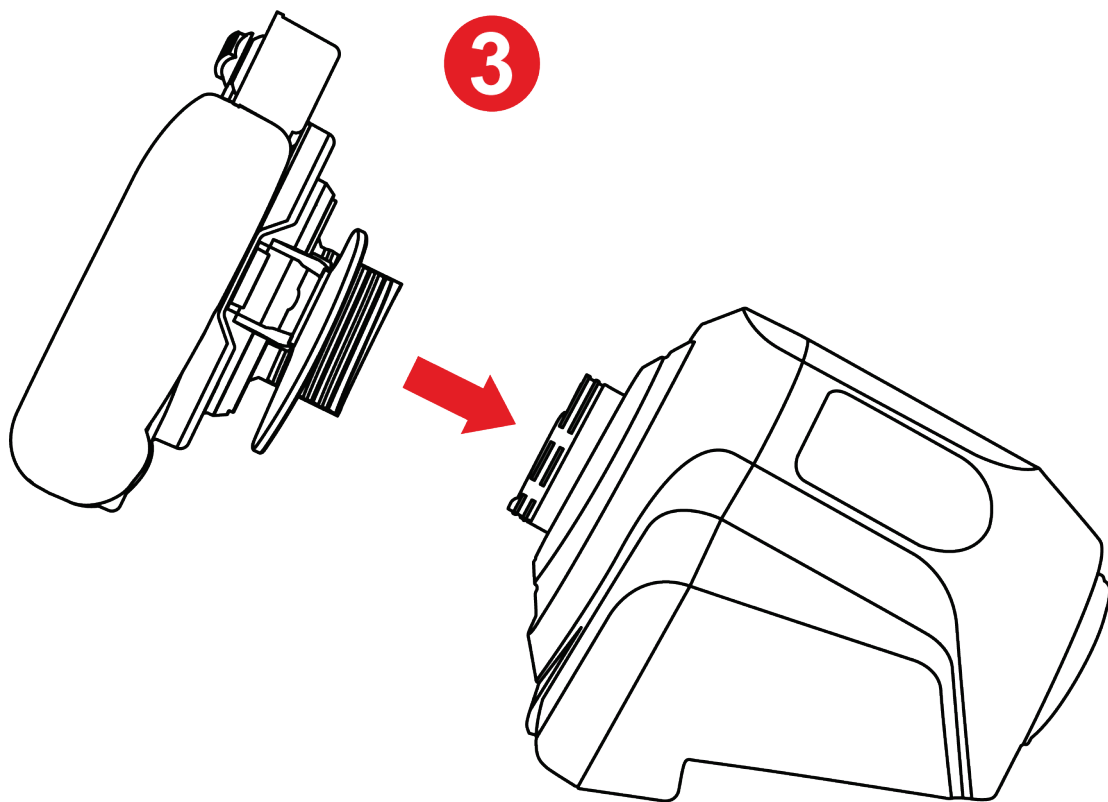

3 將方向盤安裝到底座中。



按照底座使用者手冊中規定的安裝程式操作。



如果您打算在 T818 底座上使用快拆轉接頭，切勿將快拆轉接頭（隨 T818 底座提供，亦可單獨出售）連接到適用於螺紋式底座的快拆支架。

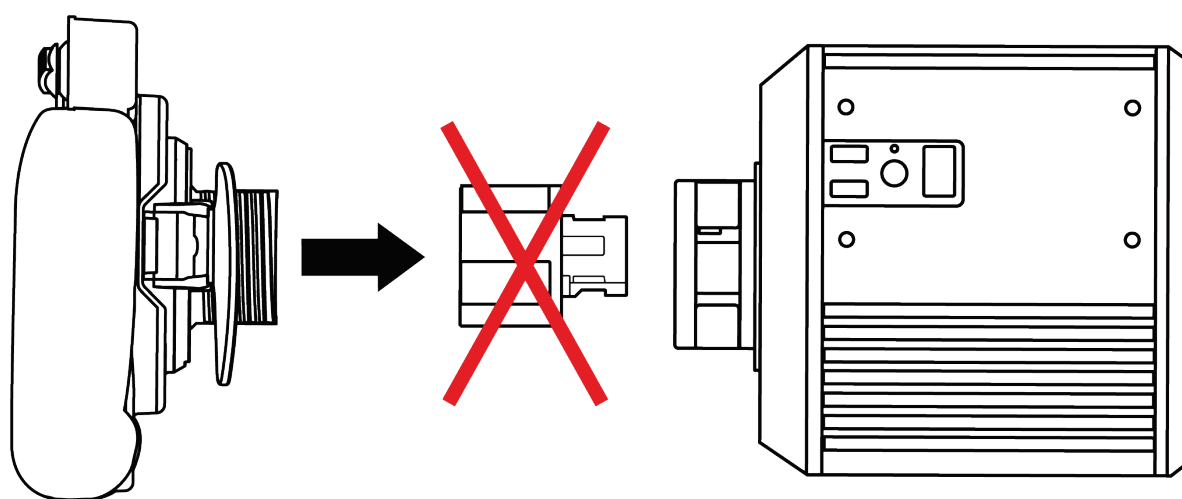
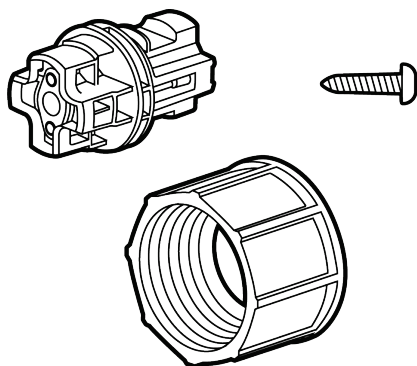

要在 T818 底座或配備門鎖式底座接頭的底座上使用，請僅使用隨 **Ferrari 488 GT3 Wheel Add-On** 提供的適用於門鎖式底座的快拆支架。



5. 對應

針對 PC 進行對應

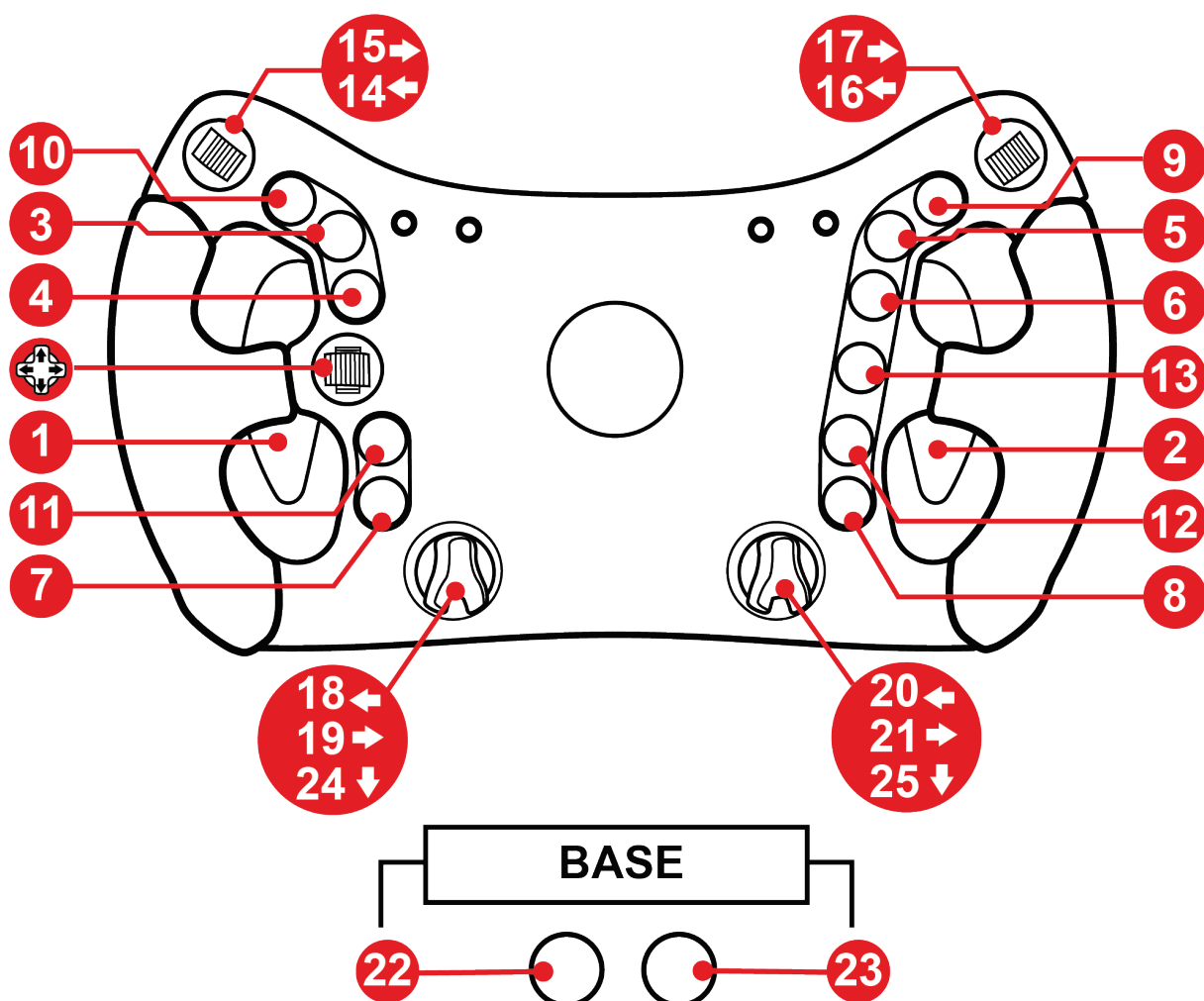



針對 PS4™/PS5™ 進行對應

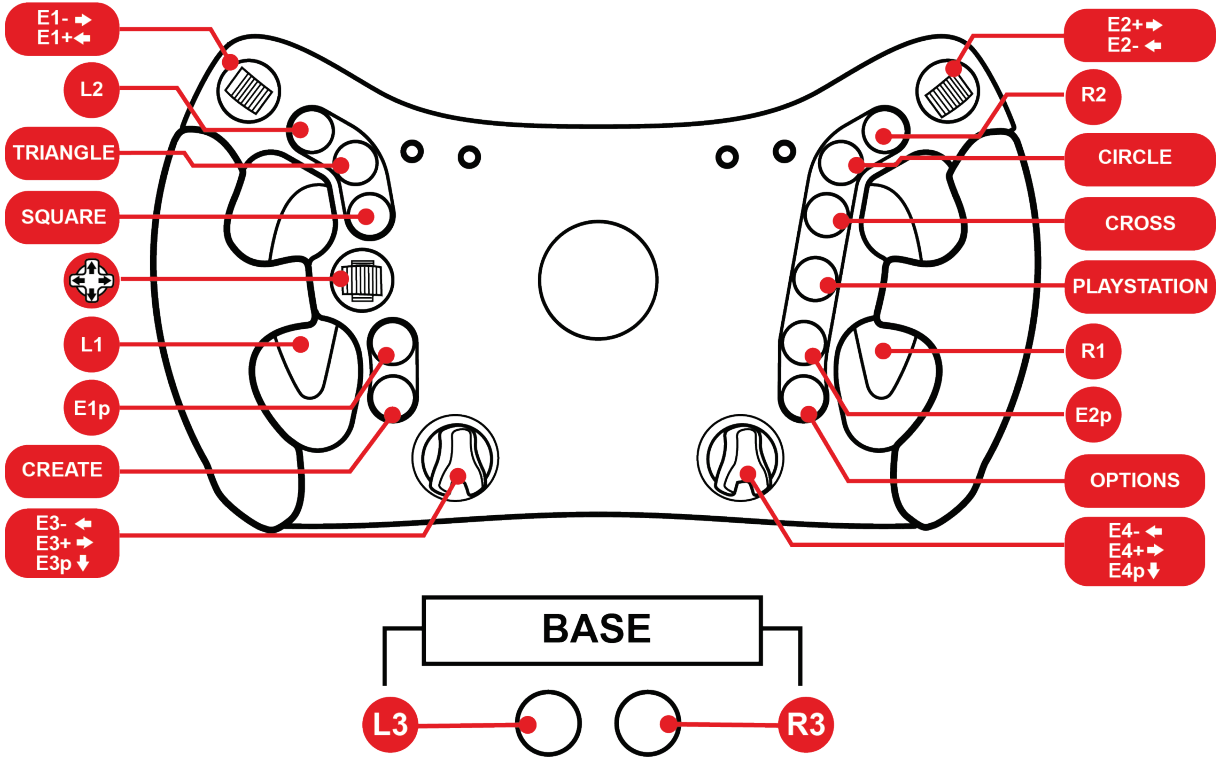



針對 Xbox Series/Xbox One 進行對應

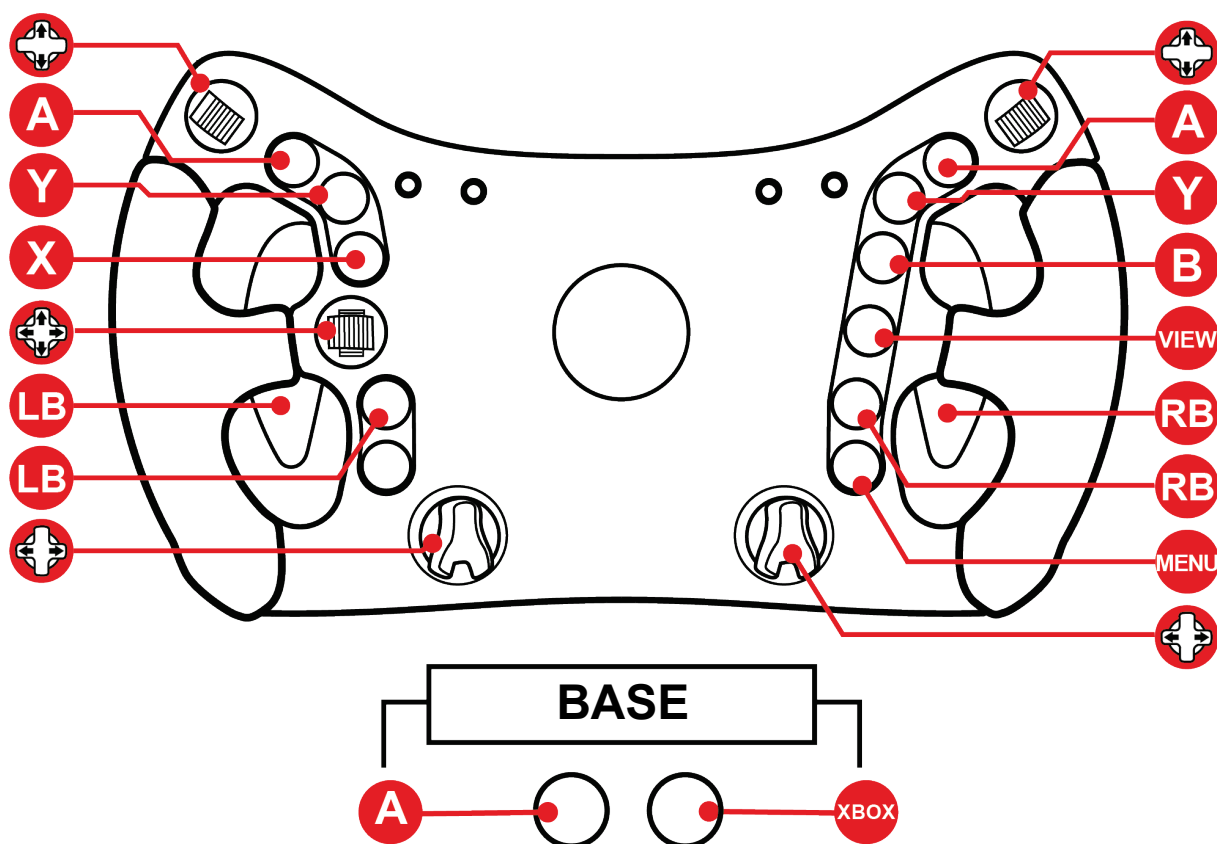

在 Xbox Series 和 Xbox One 上：

- 由於遊戲主機通訊協定的限制，Ferrari 488 GT3 Wheel Add-On 上的 LED 無法正常工作。
- 某些功能（編碼器、操作按鈕數）受遊戲主機通訊協定的限制。



6. LED 的運作

Ferrari 488 GT3 Wheel Add-On 透過 LED 顯示比賽資料：旗幟、檢修區和轉速 (RPM)。

您可根據所使用的模式（GT3 或 Formula）來自訂所顯示的資料（LED 轉速指示燈的亮度和顏色）。

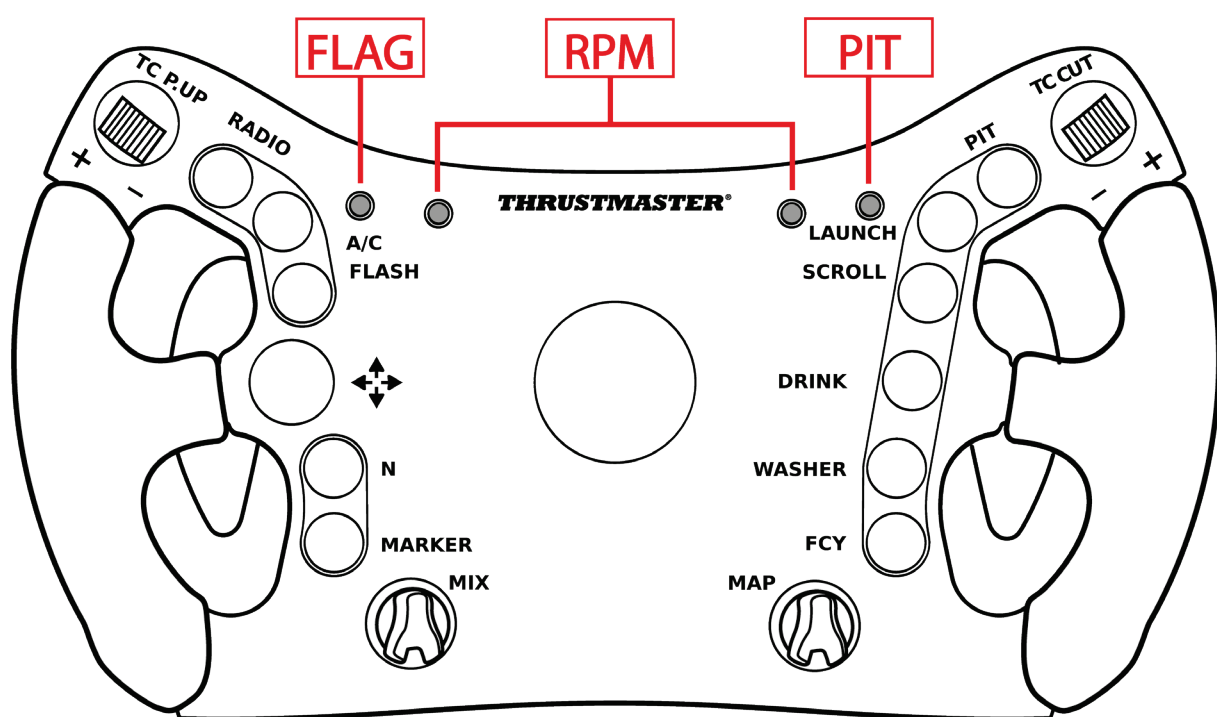

這些 LED 在 PC 和 PS4™/PS5™ 上均可正常運作。

在 Xbox Series 和 Xbox One 上，由於遊戲主機通訊協定的限制，這些 LED 無法正常工作。



如何進入/退出 LED 菜單

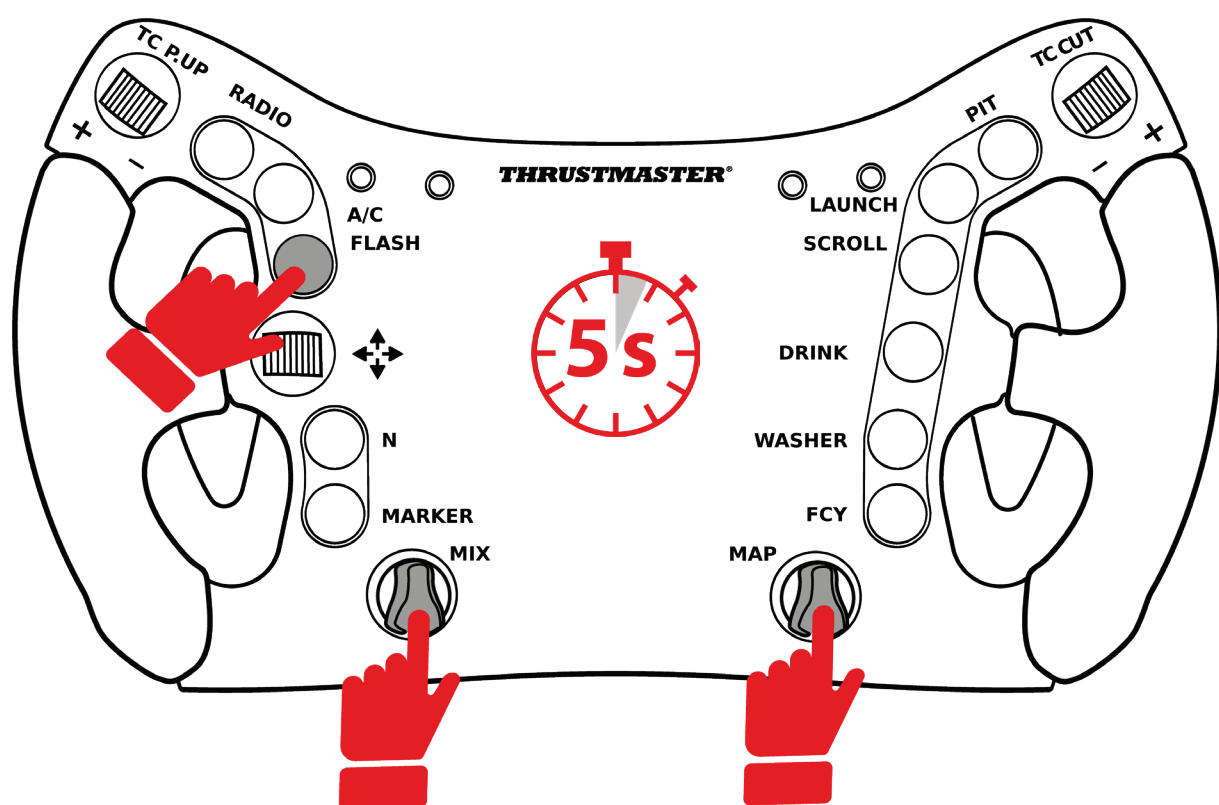

- 要進入 LED 菜單，請同時按 **FLASH** 按鈕和兩個旋轉編碼器並保持 **5 秒鐘**，然後鬆開它們。
- 要退出 LED 菜單，請同時按 **FLASH** 按鈕和兩個旋轉編碼器，然後鬆開它們。



FLAG

RPM

PIT

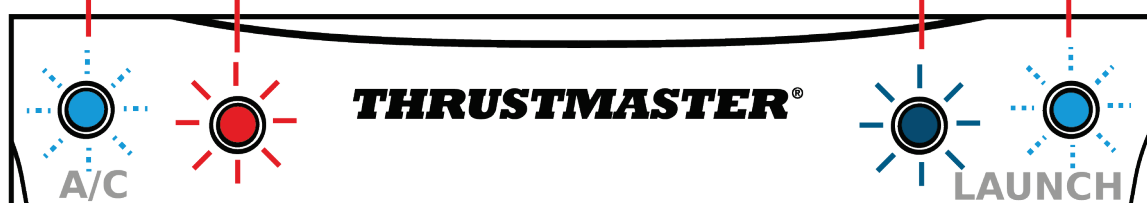

進入 **LED** 菜單：FLAG 和 PIT LED 以及 RPM LED 之一（左側紅色 LED 或右側藍色 LED）會點亮。



退出 **LED** 菜單：所有四個 LED 均會關閉。



如何調節 LED 亮度

- 透過同時按 **FLASH** 按鈕和兩個旋轉編碼器並保持 5 秒鐘，然後鬆開它們，進入 LED 功能表。
- 向左轉動左編碼器 (**MIX**) 可降低亮度，向右轉動可提高亮度。



- 透過同時按 **FLASH** 按鈕和兩個旋轉編碼器，然後鬆開它們，退出 LED 功能表。



如何變更 LED 模式：GT3 或 Formula

- 透過同時按 **FLASH** 按鈕和兩個旋轉編碼器並保持 5 秒鐘，然後鬆開它們，進入 LED 功能表。
- 向左轉動右編碼器 (**MAP**) 以選取 GT3 模式（紅色 LED）或向右轉動以選取 Formula 模式（藍色 LED）。



GT3 模式（預設模式）



FORMULA 模式

- 透過同時按 **FLASH** 按鈕和兩個旋轉編碼器，然後鬆開它們，退出 LED 功能表。



7. 自訂換擋撥片

您可調節 **Ferrari 488 GT3 Wheel Add-On** 換擋撥片的間距和行程範圍。

間距是指調整換擋撥片的寬度，這會改變把手與換擋撥片之間的距離。

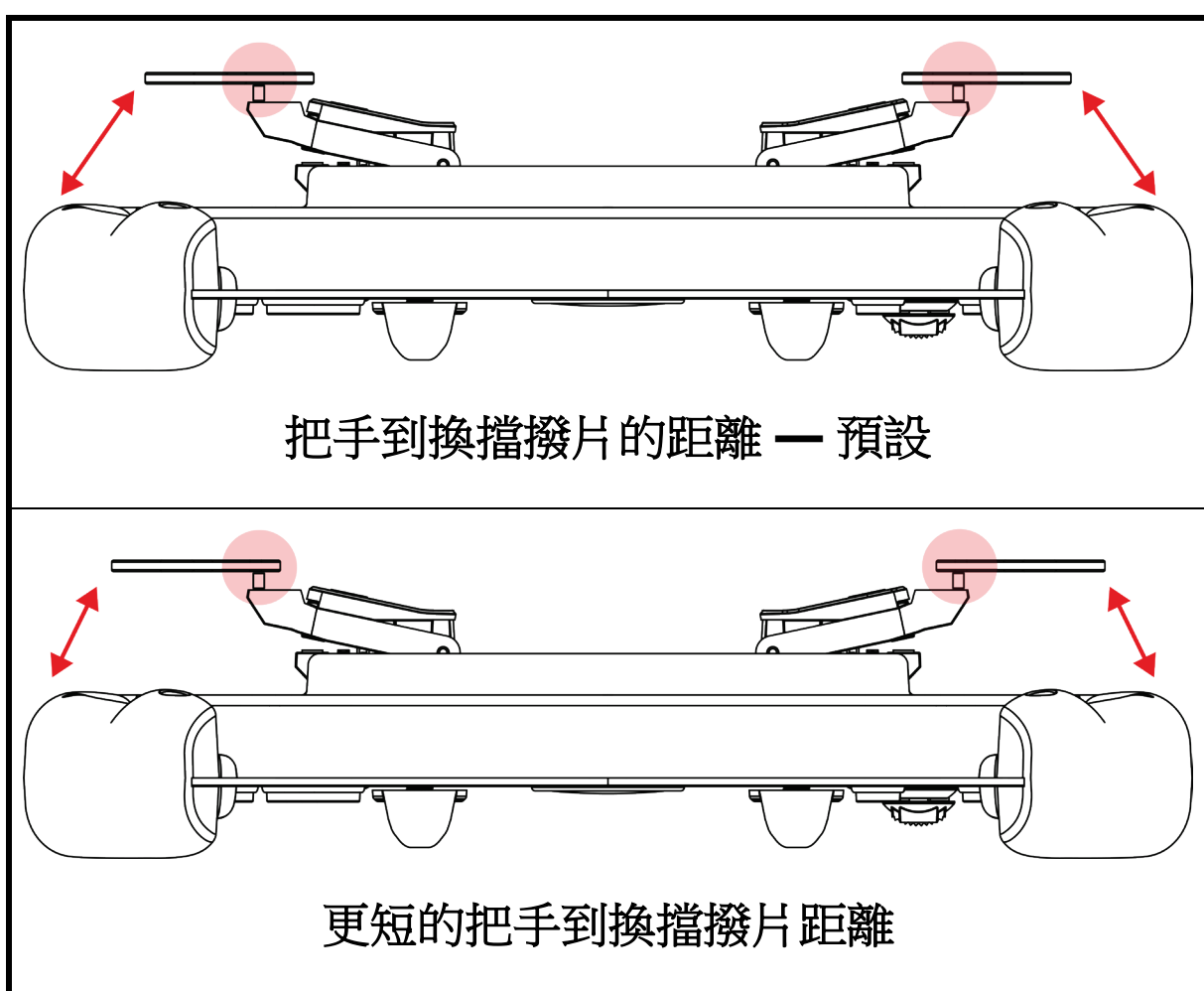



使用隔墊來調整行程範圍會改變換擋撥片的啟用距離。

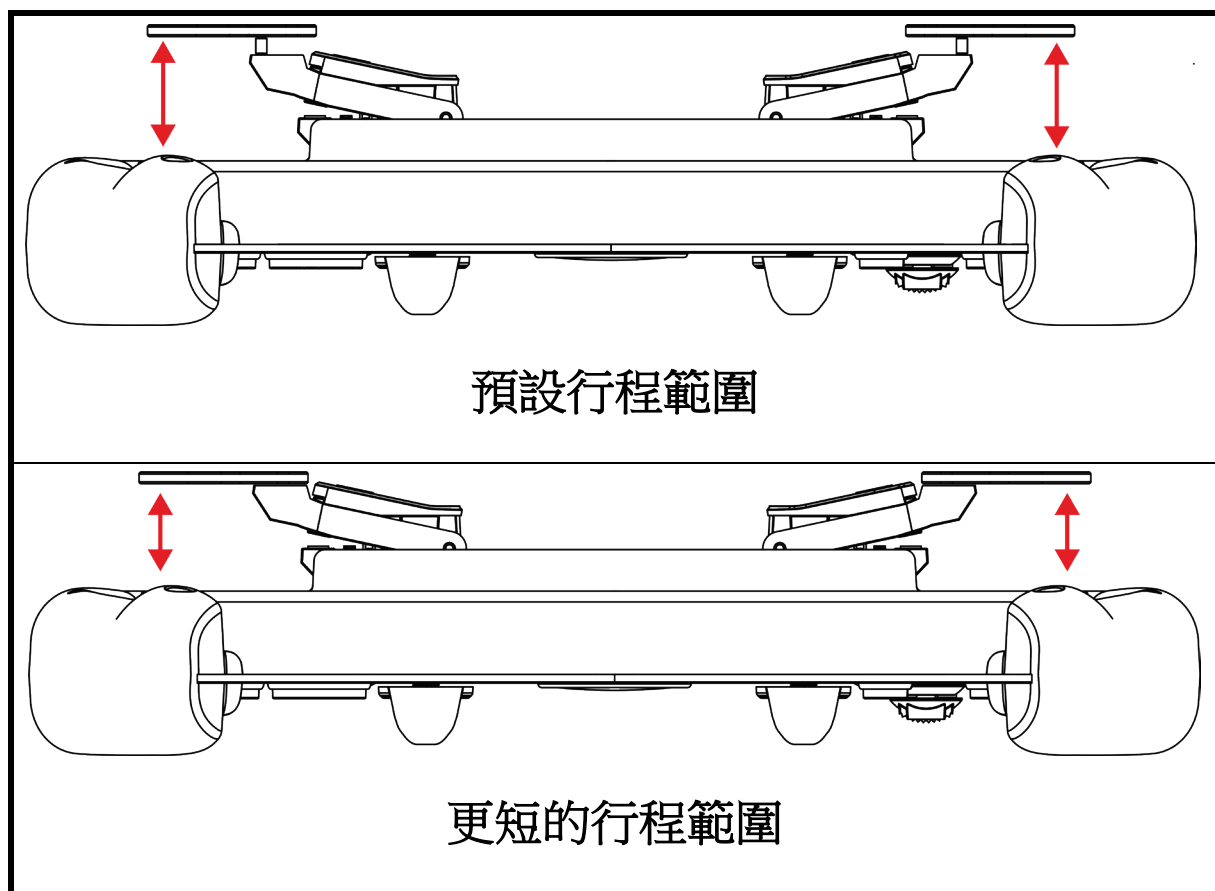

您還可以使用隨附的墊片組來調整**磁性敏感度**和換擋撥片的**音量**。

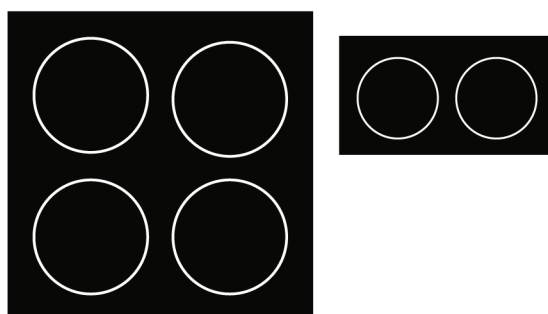



如何調整換擋撥片的間距

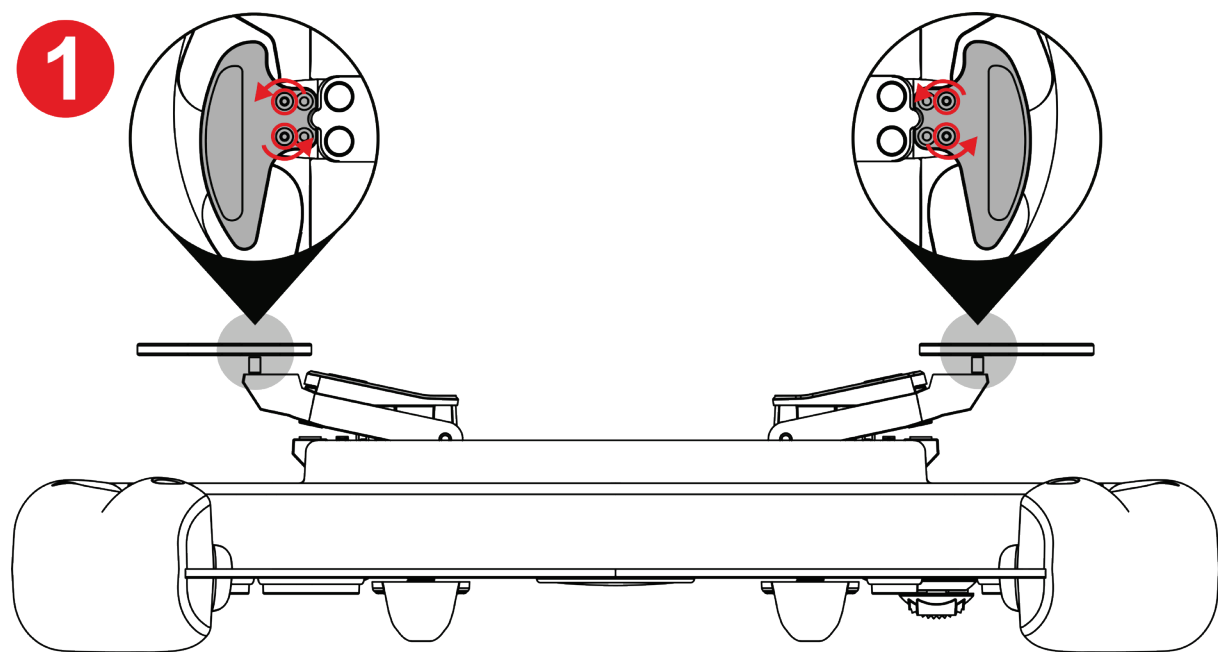

1 使用隨附的梅花扳手擰松換擋撥片的四個螺絲。

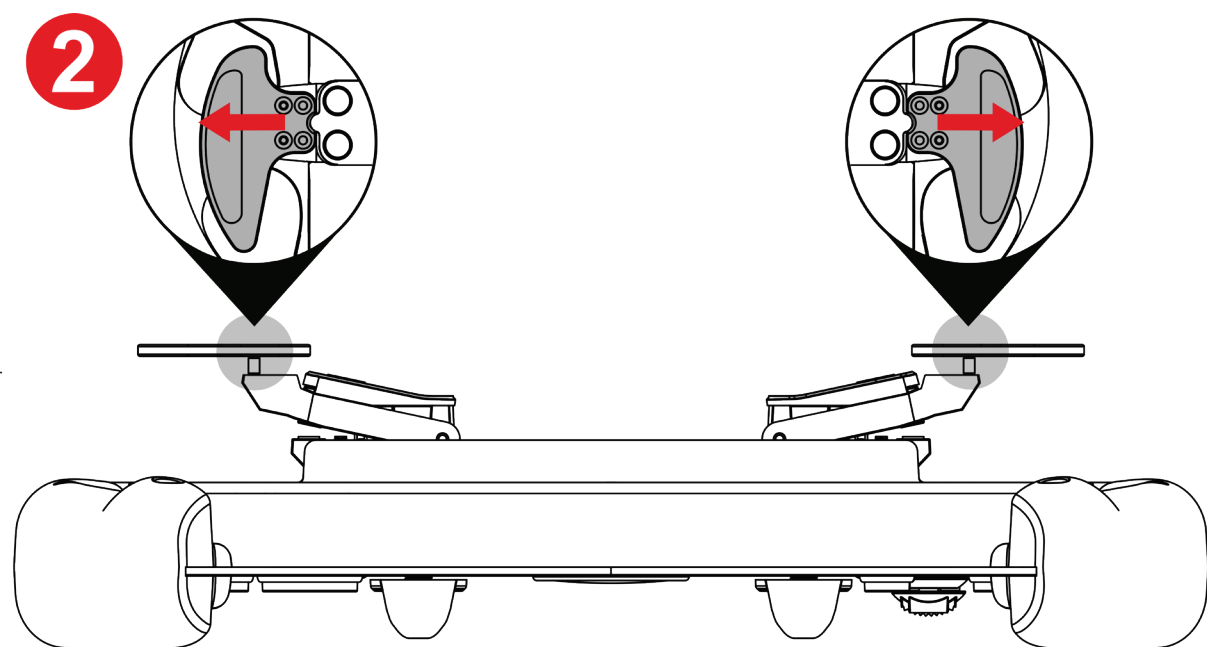

2 將換擋撥片朝外放置，對準螺孔。

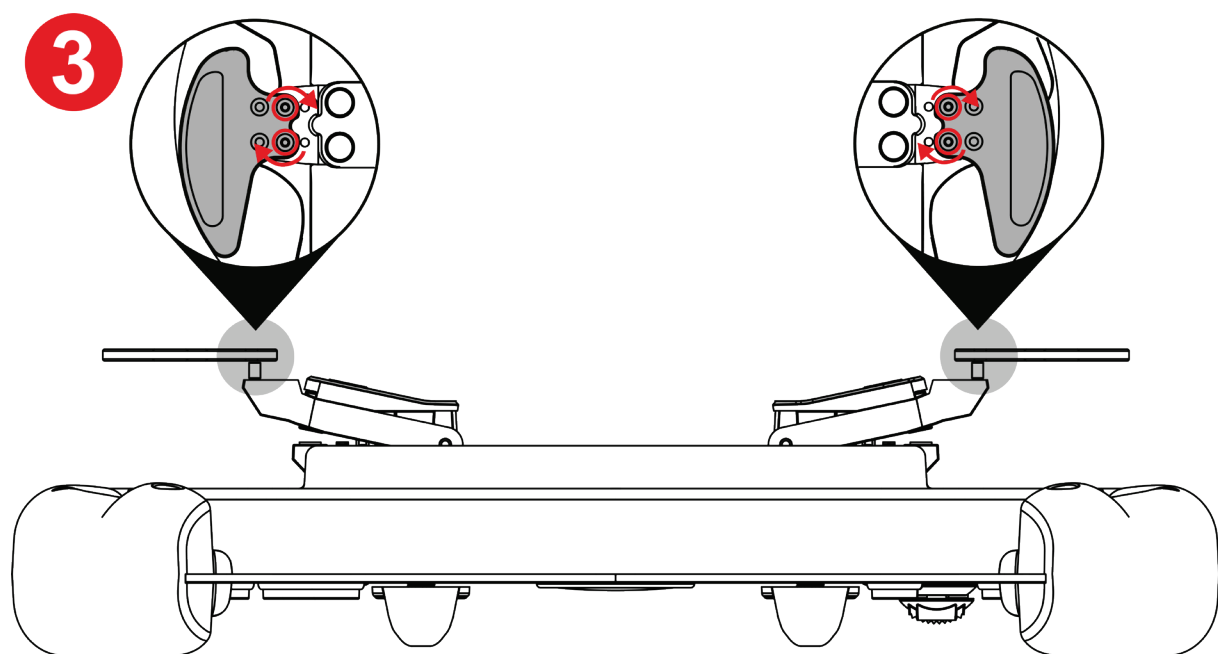

3 使用隨附的梅花扳手擰緊換擋撥片的四個螺絲。



如何調整換擋撥片的行程範圍

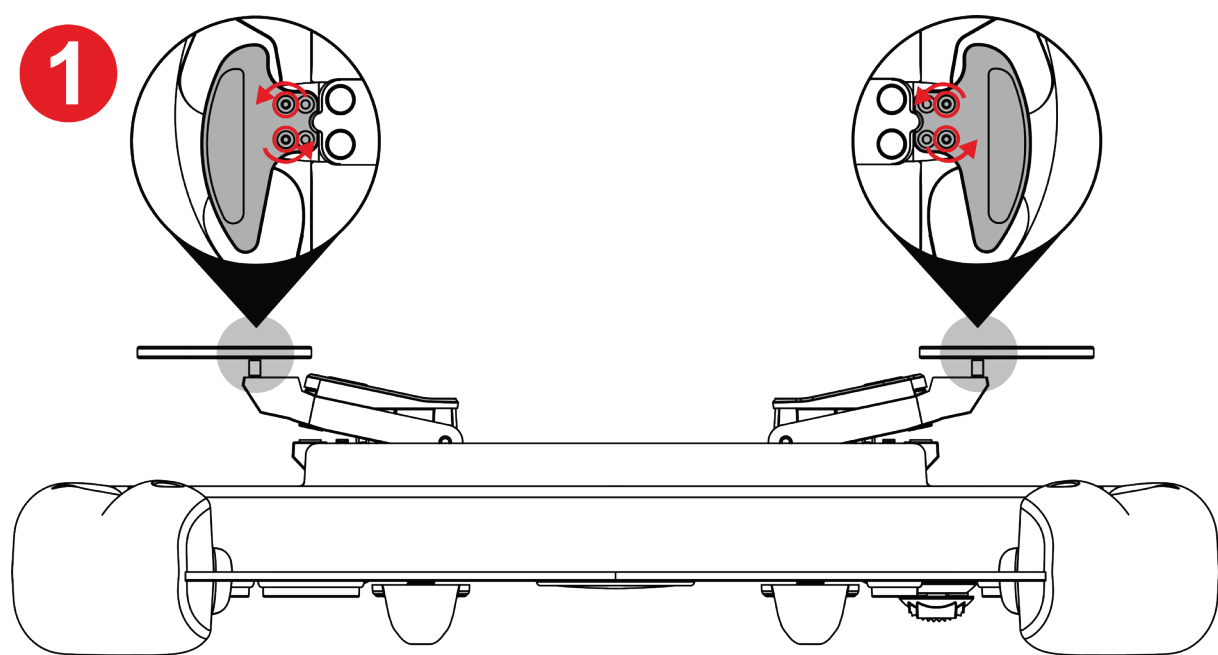

❶ 使用隨附的梅花扳手擰松換擋撥片的四個螺絲。

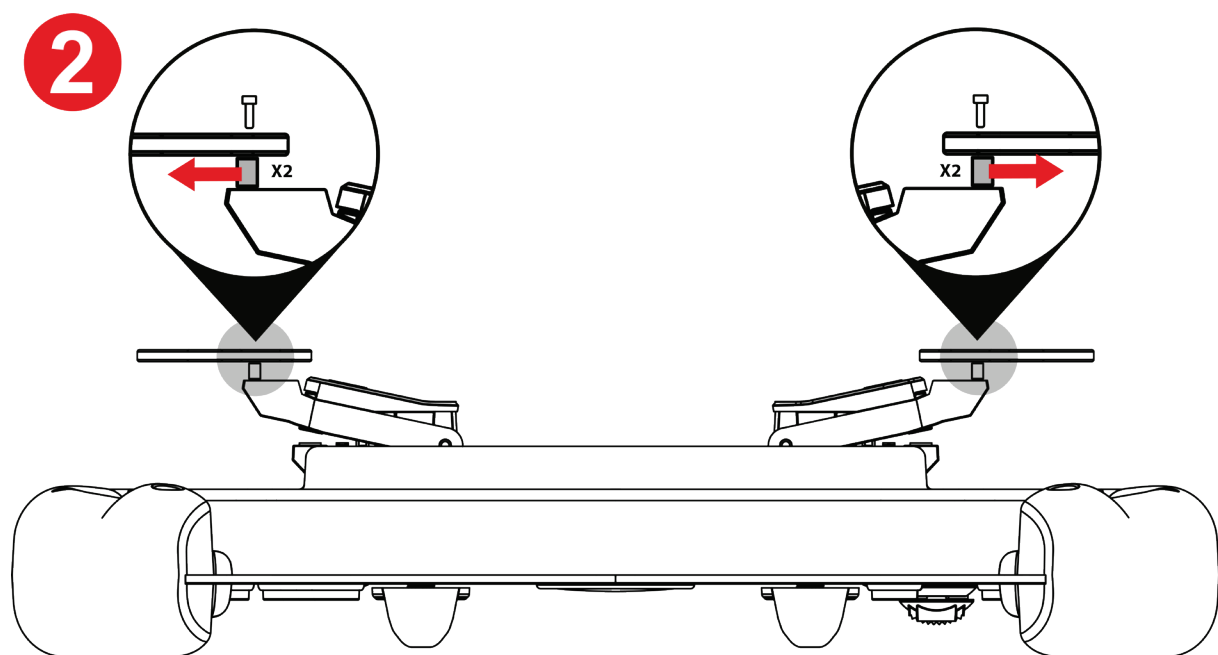

❷ 取下隔墊。

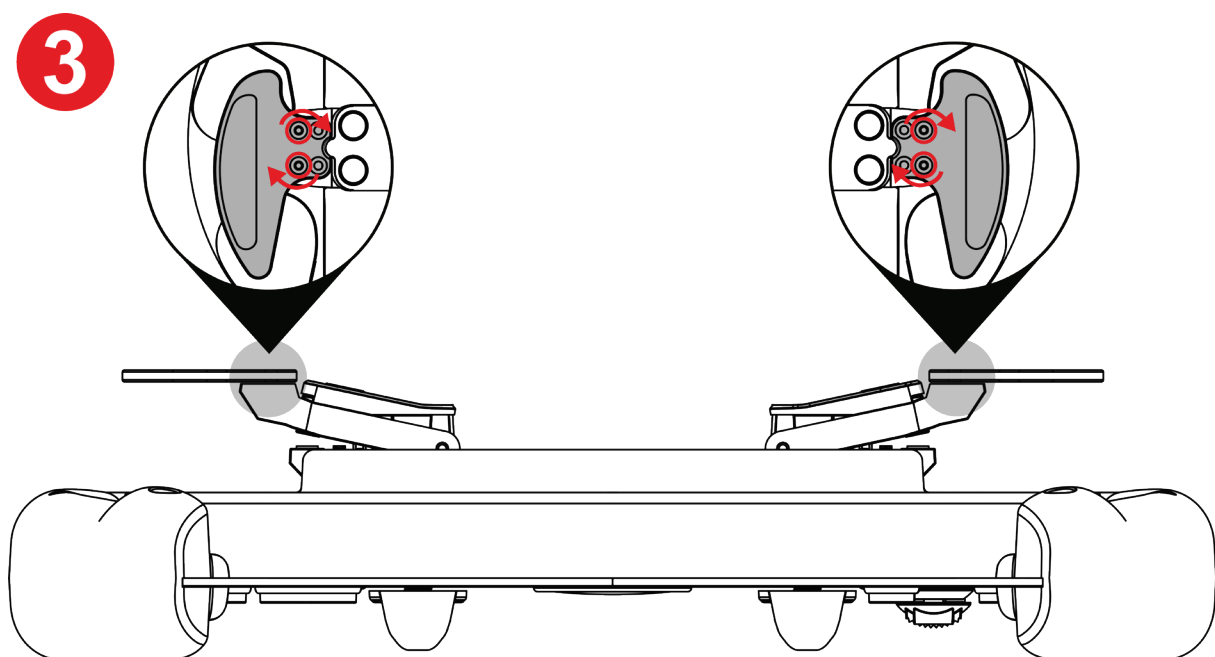

3 使用隨附的梅花扳手擰緊換擋撥片的四個螺絲。



如何調整磁性敏感度和換擋撥片的音量

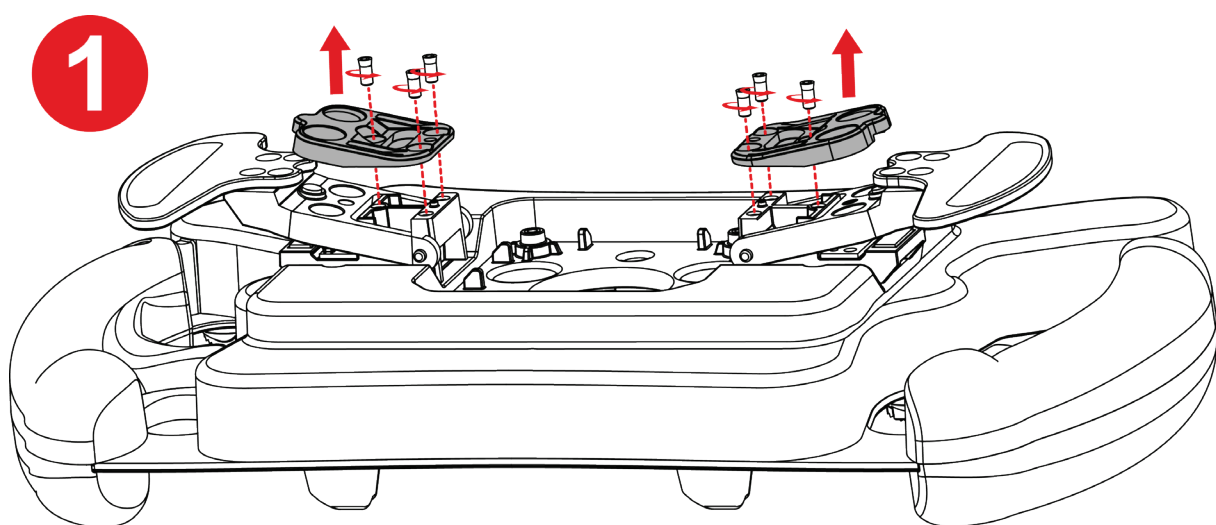

❶ 透過使用隨附的梅花扳手擰松六個止動螺絲，取下磁性限位器。

❷

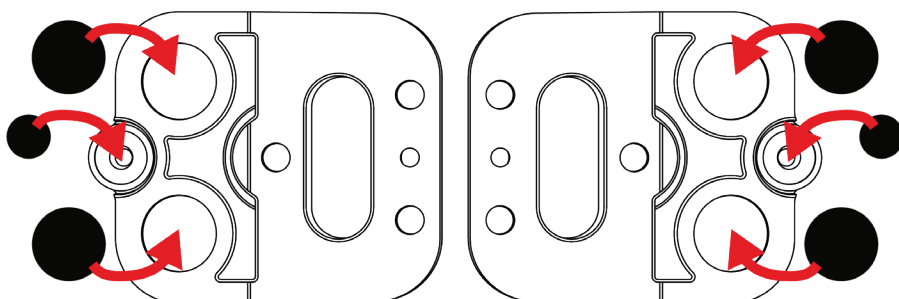
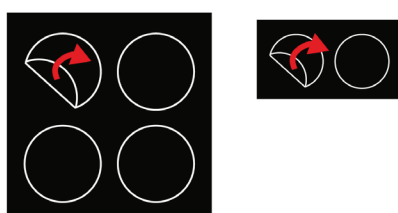

❷ 撕下提供的墊片，並將其貼到磁性限位器下方的適當位置。



有關可能的組態及其作用，請參閱**磁性敏感度和緩動盤音量衰減表**



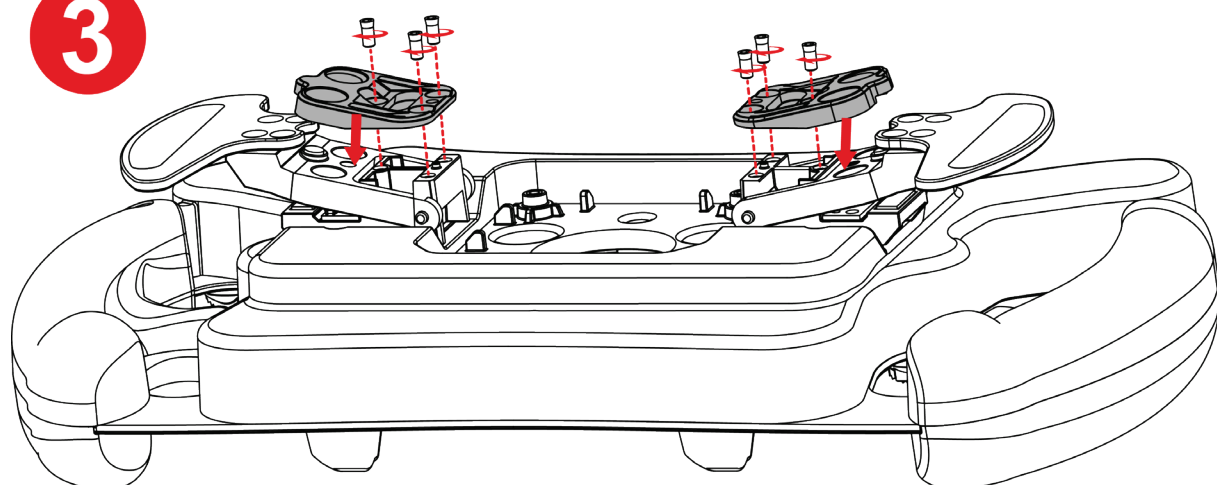

3

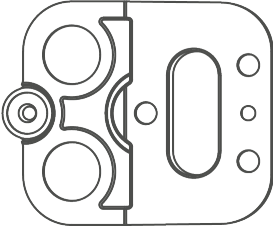
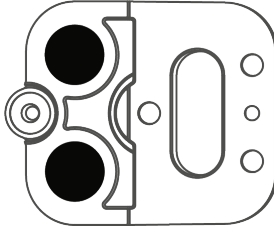
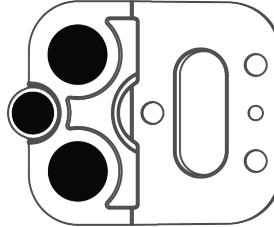
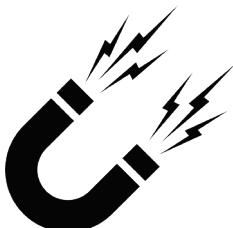

3 透過使用隨附的梅花扳手擰緊六個止動螺絲，重新安裝磁性限位器。

磁性敏感度和緩動盤音量衰減表

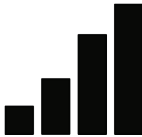
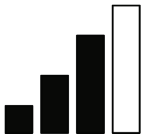
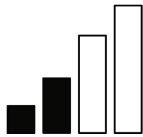
	 (預設)		
磁性敏感度			
音量			



8. 常見問題解答和技術支援

您對 Ferrari 488 GT3 Wheel Add-On 是否有任何疑問，或者您是否遇到任何技術問題？若有的話，請瀏覽 Thrustmaster（圖馬思特）技術支援網站：

<https://support.thrustmaster.com/product/ferrarif488gt3addon>.

在此頁面中，您還可以更新方向盤的韌體。



THRUSTMASTER®

FERRARI 488 GT3 WHEEL ADD-ON

**PC(Windows 10/11)
PS4™/PS5™
Xbox Series/Xbox One**

사용설명서



제품을 설치하기 전, 제품을 사용하기 전, 그리고 유지보수하기 전에 본 설명서에 제공된 지침을 주의 깊게 읽으십시오. 안전 지침을 따르십시오. 이 지침을 따르지 않으면 사고가 나거나 제품이 손상될 수 있습니다. 나중에 지침을 참조할 수 있도록 본 설명서를 보관하십시오.

목차

1.	박스 내용물.....	5
2.	기능	6
3.	휠 사용에 관한 정보.....	8
4.	킥 릴리스 홀더 설치.....	13
	<i>래치 베이스 킥 릴리스 홀더 설치</i>	<i>14</i>
	<i>나사 베이스 킥 릴리스 홀더 설치</i>	<i>17</i>
5.	맵핑	21
	<i>PC 용 맵핑.....</i>	<i>21</i>
	<i>PS4™/PS5™ 용 맵핑.....</i>	<i>22</i>
	<i>Xbox Series/Xbox One 용 맵핑</i>	<i>23</i>
6.	LED 작동	24
	<i>LED 메뉴 진입/종료 방법</i>	<i>25</i>
	<i>LED 밝기 조절 방법.....</i>	<i>27</i>
	<i>LED 모드 변경 방법: GT3 또는 Formula.....</i>	<i>28</i>

7.	패들 시프터 커스터마이제이션	29
	패들 시프터 간격 조정 방법.....	31
	패들 시프터 도달 거리 조정 방법	33
	패들 시프터의 자기 감도 및 사운드 레벨 조정 방법	35
8.	자주 묻는 질문 및 기술 지원.....	37



FERRARI 488 GT3 WHEEL ADD-ON

모든 Thrustmaster 휠 베이스와 호환되며 퍼포먼스용으로 디자인된 휠인 Ferrari 488 GT3 Wheel Add-On 을 통해 GT 레이싱 전설이 되어보세요.

본 매뉴얼은 최상의 조건에서 Ferrari 488 GT3 Wheel Add-On 을 설치하고 사용하는 데 도움이 됩니다. 레이싱을 시작하기 전에 지침과 경고를 주의 깊게 읽으십시오. 제품을 최대한 즐길 수 있도록 도와줄 것입니다.



1. 박스 내용물

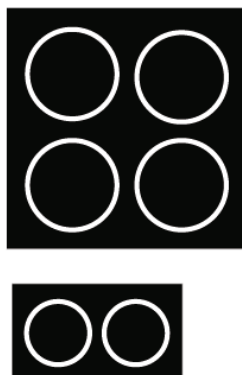
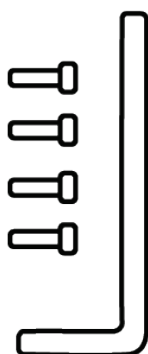
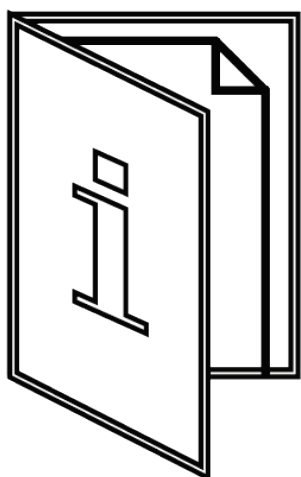
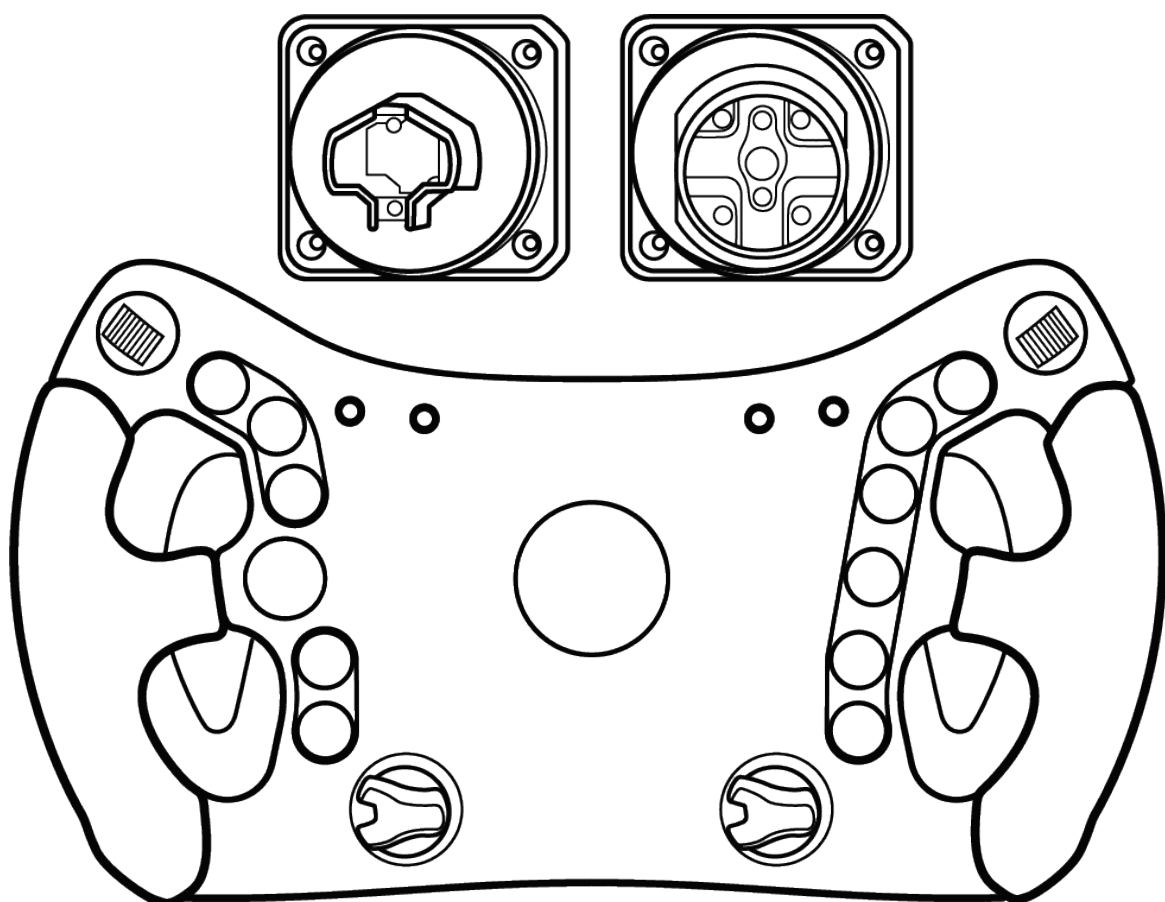



2. 기능

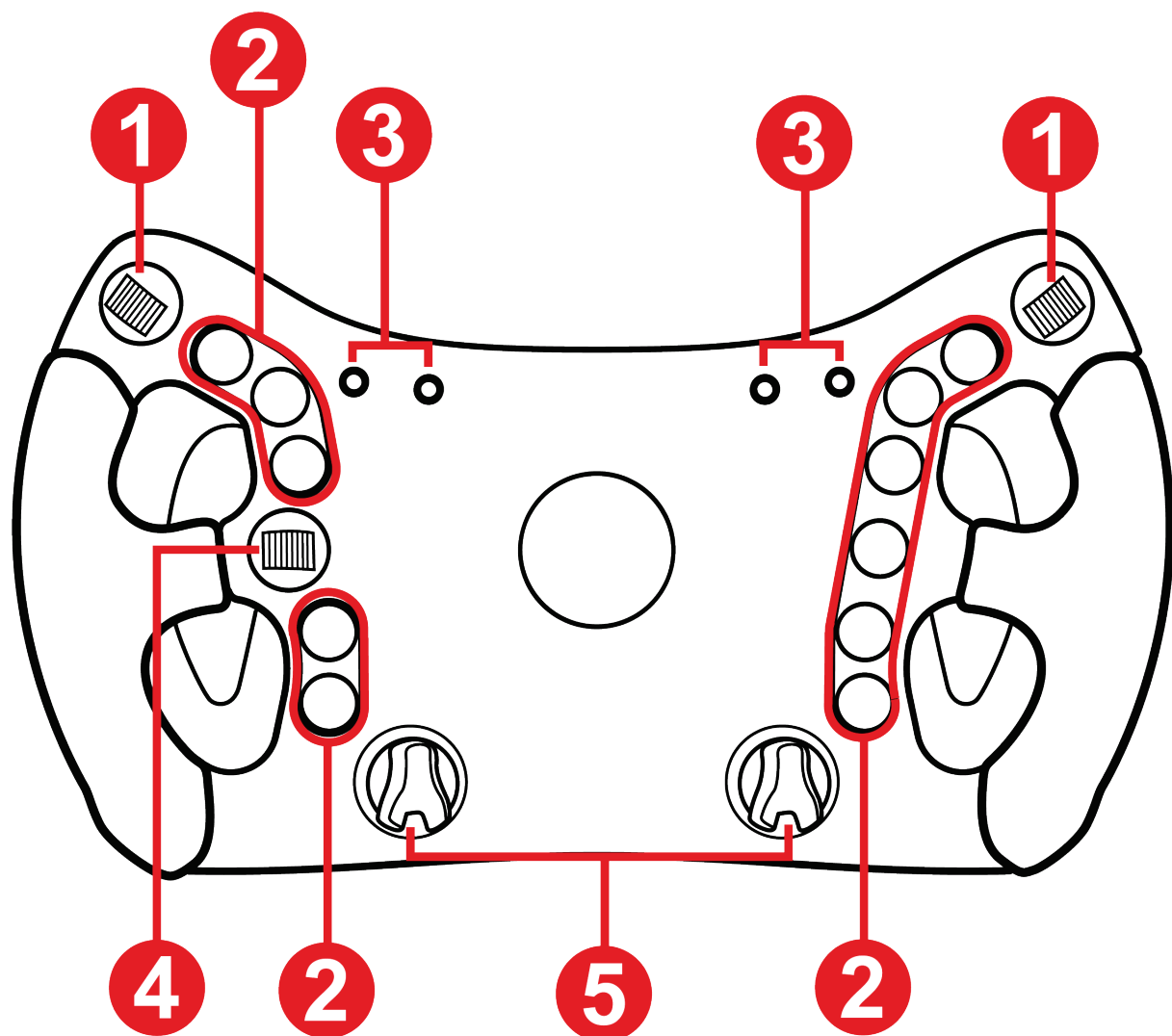

- ❶ 섬 인코더
- ❷ 11 개의 동작 버튼
- ❸ RPM LED 및 레이스 데이터(플래그, 피트)
- ❹ D 패드
- ❺ 회전 인코더

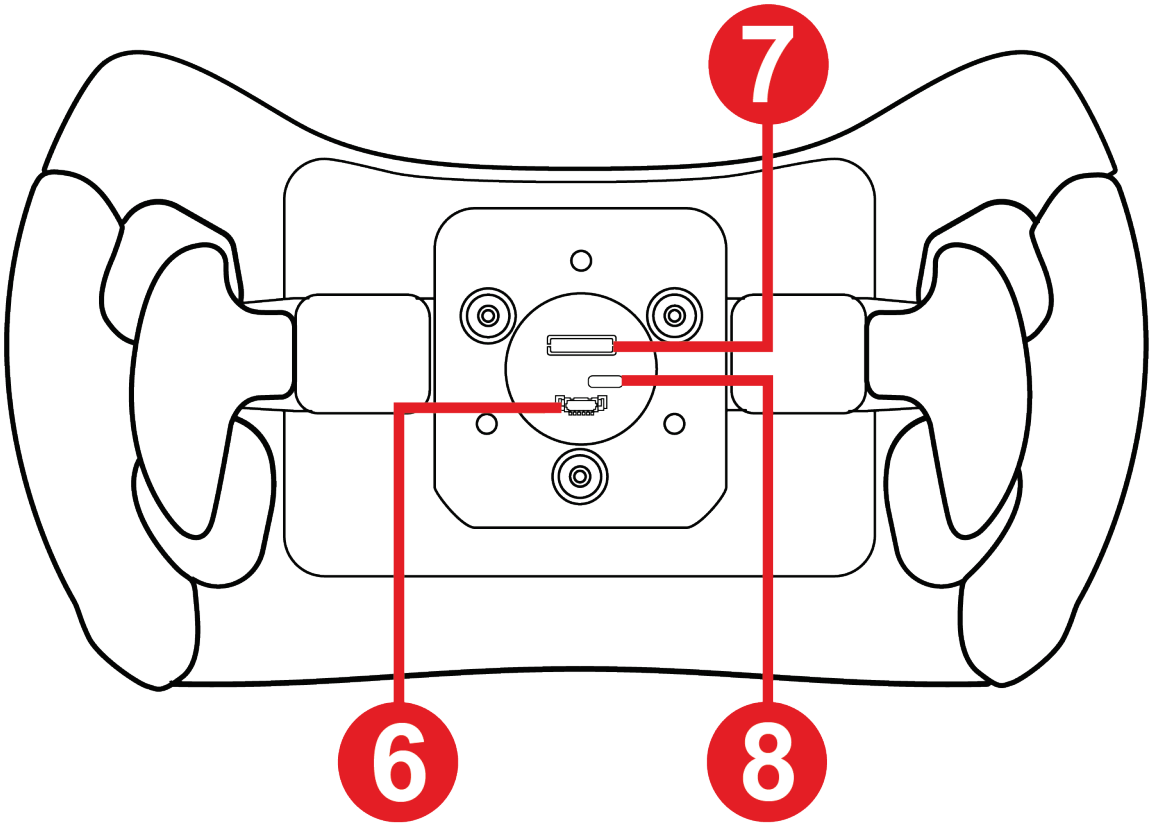

⑥ 나사 베이스 퀵 릴리스 홀더의 연결 포트

⑦ 래치 베이스 퀵 릴리스 홀더의 연결 포트

⑧ **USB-C** 포트(펌웨어 업데이트 필요 시 - 케이블 미포함)

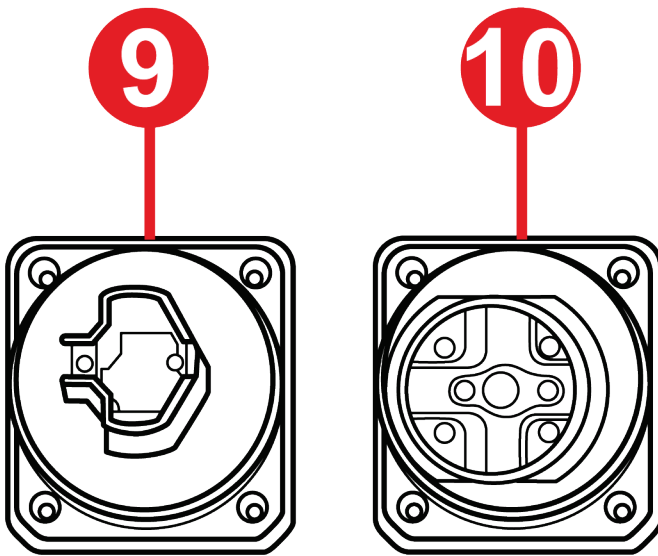

⑨ 래치 베이스 퀵 릴리스 홀더

⑩ 나사 베이스 퀵 릴리스 홀더



3. 휠 사용에 관한 정보



문서

이 제품을 사용하기 전에 본 문서를 다시 주의 깊게 읽고 나중에 참고할 수 있도록 보관하세요.



감전

- 본 제품은 건조한 곳에 보관해야 하며, 먼지나 햇빛에 노출시키지 마십시오.
- 커넥터 및 케이블을 비틀거나 잡아당기지 마십시오.
- 연결 방향을 준수하십시오.
- 본 제품이나 제품의 커넥터에 액체를 흘리지 마십시오.
- 제품 합선을 일으키지 마십시오.
- 제품을 절대 분해하지 말고(본 매뉴얼에 제시된 커스터마이제이션의 경우는 제외)불에 제품을 던지거나 고온에 노출시키지 마십시오.
- 장치를 열지 마십시오. 장치 내부에는 사용자가 수리할 수 있는 부품이 없습니다. 모든 수리는 제조업체, 지정된 대리점 또는 자격을 갖춘 기술자가 수행해야 합니다.



게임 공간 확보

- 사용자 실천을 방해하거나 부적절한 움직임을 유발하거나 다른 사람에 의해 방해(예: 컵, 전화, 열쇠)를 유발할 수 있는 물체를 게임 구역에 배치하지 마십시오.
- 전원 케이블을 카펫 또는 러그, 담요 또는 다른 물건으로 덮지 마시고 사람들이 걸어 다니는 곳에 케이블을 두지 마십시오.



포스 피드백 및 반복적인 움직임으로 인한 부상

포스 피드백 레이싱 핸들을 사용하면 근육이나 관절의 통증이 유발될 수 있습니다. 이러한 문제를 예방하려면 다음 사항을 준수하십시오.

- 미리 워밍업을 하고 연습을 장시간 하지 마십시오.
- 매 시간 연습 후에는 10~15 분 정도 휴식을 취하십시오.
- 손, 손목, 팔, 발 또는 다리가 피로하거나 통증이 있는 경우 버튼을 눌러 포스 피드백을 끄고 베이스 전원을 꺼서, 연습을 다시 시작하기 전에 몇 시간 동안 휴식을 취하십시오.
- 연습을 다시 시작할 때 위에 설명한 증상이나 통증이 계속되는 경우에는 연습을 중단한 후 의사와 상담하십시오.
- 포스 피드백을 자신의 전문 지식과 신체 조건에 비해 너무 높은 수준으로 설정하지 마십시오.
- 장치는 16 세 미만의 사람의 손이 닿지 않는 곳에 두십시오.
- 설명서의 지침에 따라 베이스와 핸들이 올바르게 부착되었는지 확인하십시오.

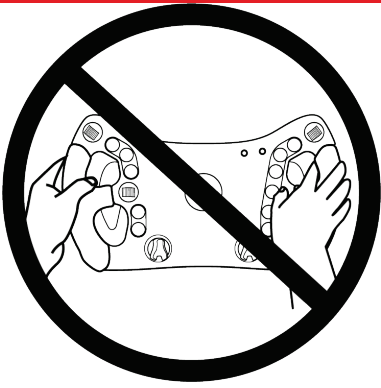

예측하지 못한, 강력하고 빠른 회전의 위험: 손이나 팔을 핸들의 개방부 또는 핸들의 회전 궤도에 절대 두지 마십시오.

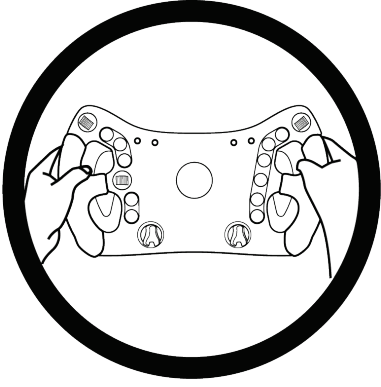

제품 사용 중에는 반드시 양손으로 올바르게 핸들을 잡되, 핸들에서 양손을 모두 놓으면 안 됩니다.



만 16세 이상인 사람만 사용할 수 있는 제품입니다.



4. 킥 릴리스 홀더 설치

Ferrari 488 GT3 Wheel Add-On 에는 Thrustmaster 베이스 형식에 해당하는 킥 릴리스 홀더 2 개가 포함되어 있습니다.

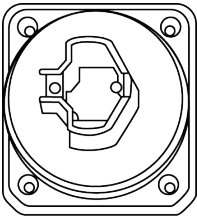
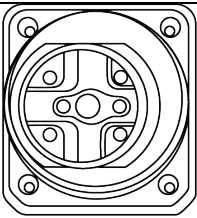
시스템	호환성
 래치 베이스 킥 릴리스 홀더	T818, T818 Ferrari SF1000 Simulator 및 향후의 Thrustmaster 베이스.
 나사 베이스 킥 릴리스 홀더	T-GT / T-GT II Servo Base, T300 RS Servo Base, TS PC Racer, TS-XW, TX Racing Wheel Servo Base, TS-XW Servo Base.



매번 사용하기 전에, 본 매뉴얼의 베이스 지침에 따라 **Ferrari 488 GT3 Wheel Add-On** 이 서포트에 적절히 부착되어 있는지 확인하십시오.



래치 베이스 퀵 릴리스 홀더 설치

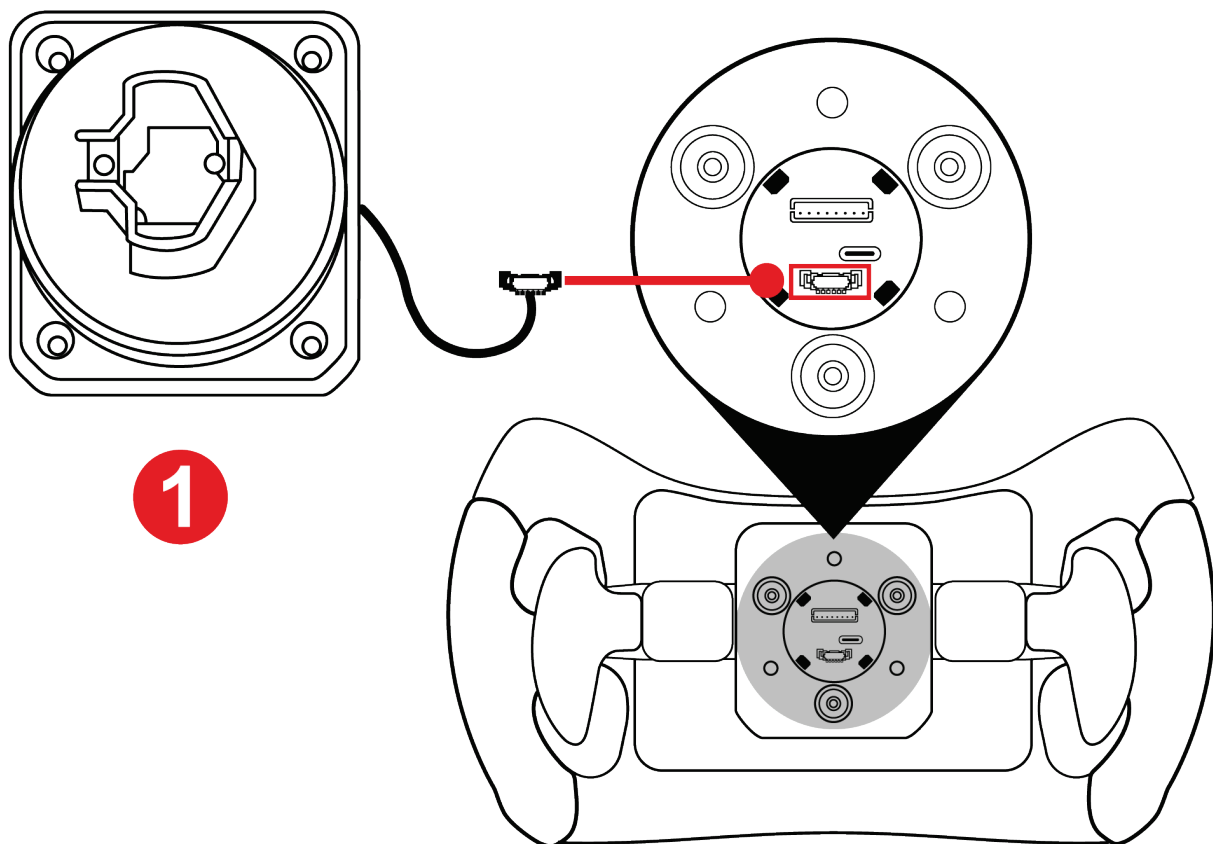

1 퀵 릴리스 홀더 커넥터를 휠 뒷면의 해당 포트에 꽂으십시오.



케이블이 끼이지 않도록하우징 안으로 집어넣은 다음 홀더를 조이십시오.

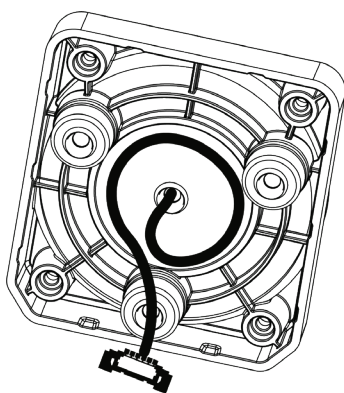

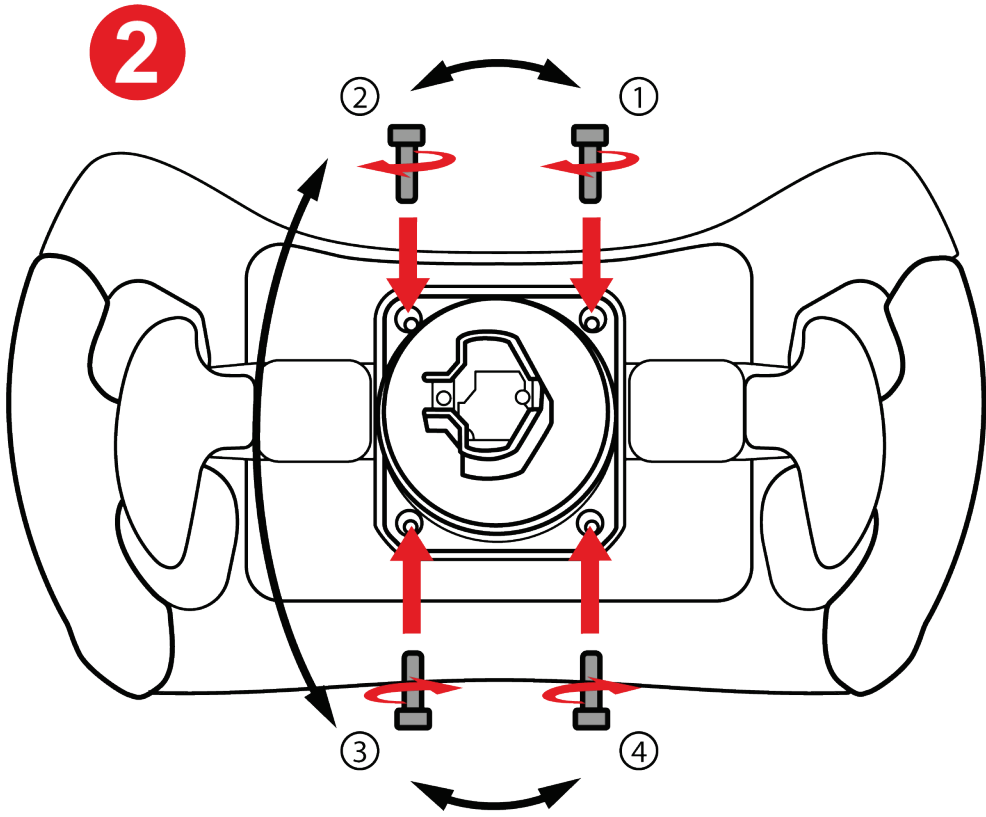

2 퀵 릴리스 홀더를 삽입하고 제공된 Torx 렌치를 사용해 조이십시오.



홀더 장착 시 나사를 과도하게 조이지 마십시오.

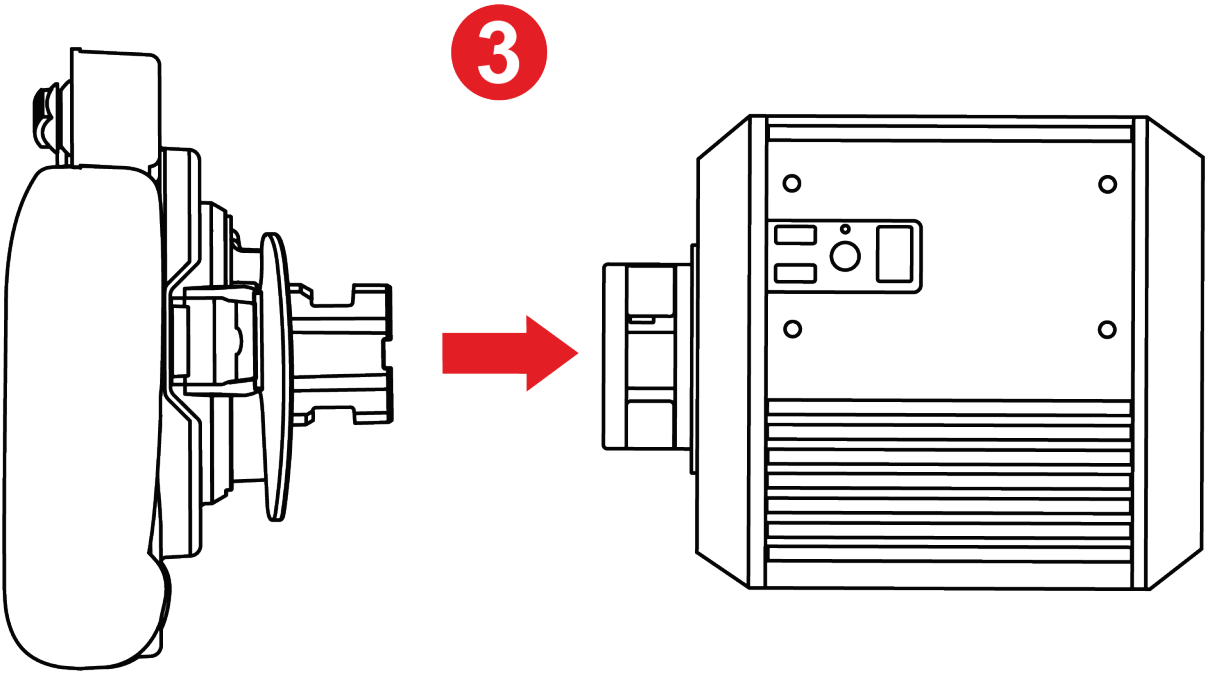

3 휠을 베이스에 장착합니다.



베이스 사용설명서에 제시된 설치 절차를
준수하십시오.



나사 베이스 퀵 릴리스 홀더 설치

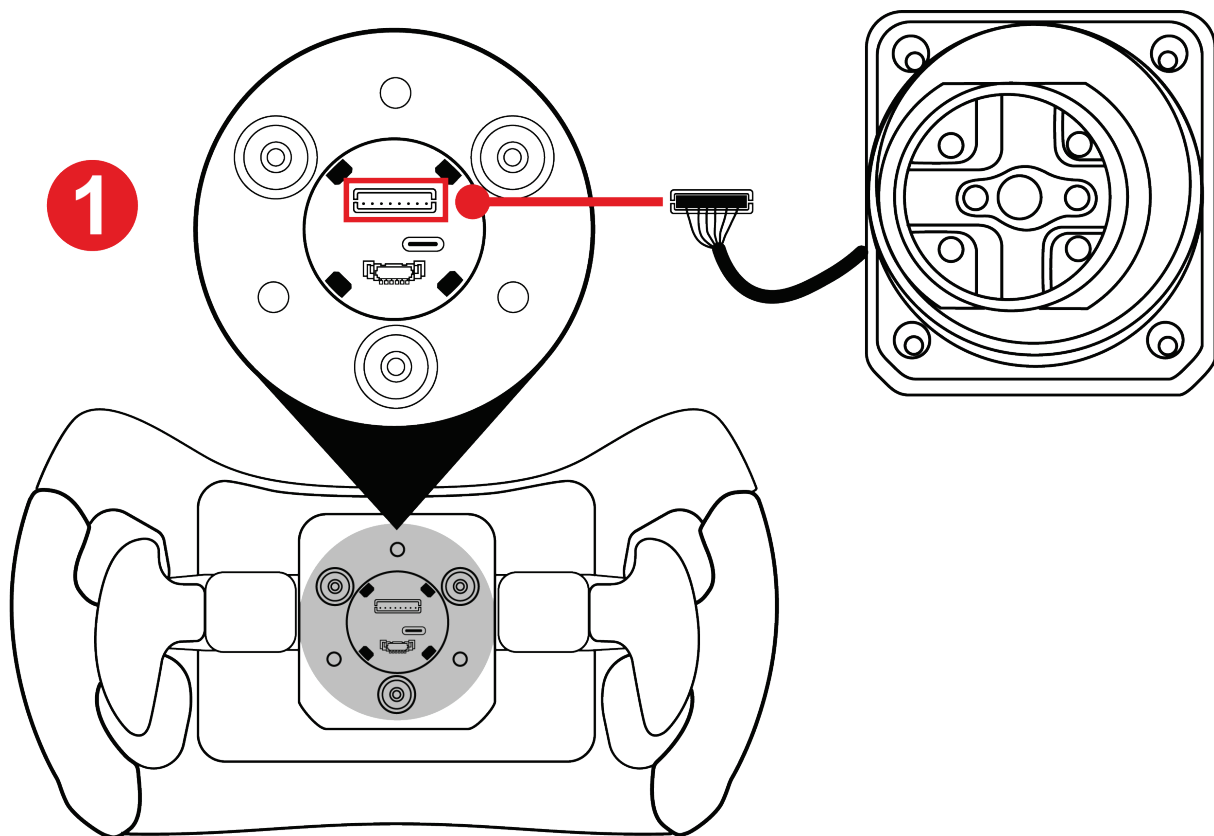

❶ 퀵 릴리스 홀더 커넥터를 휠 뒷면의 해당 포트에 꽂으십시오.



케이블이 끼이지 않도록 하우징 안으로 집어넣은 다음 홀더를 조이십시오.

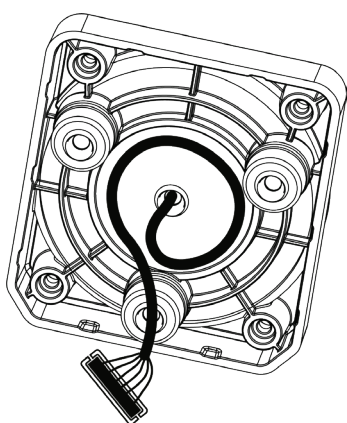

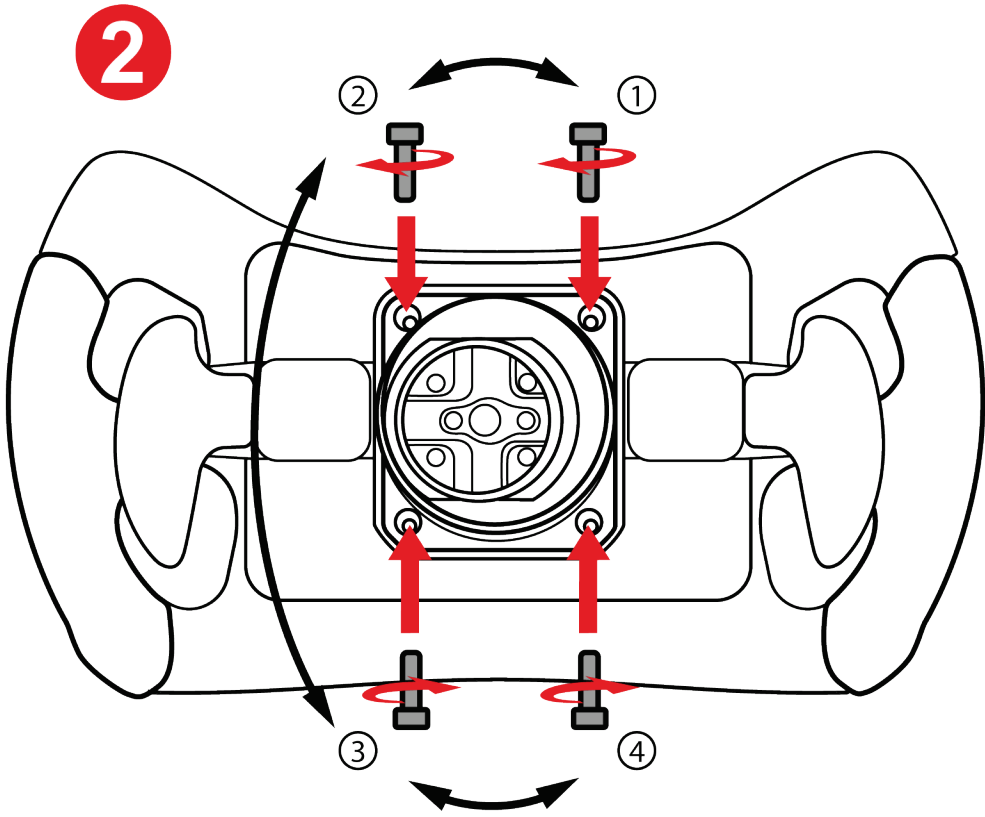

2 퀵 릴리스 홀더를 삽입하고 제공된 Torx 렌치를 사용해 조이십시오.



홀더 장착 시 나사를 과도하게 조이지 마십시오.

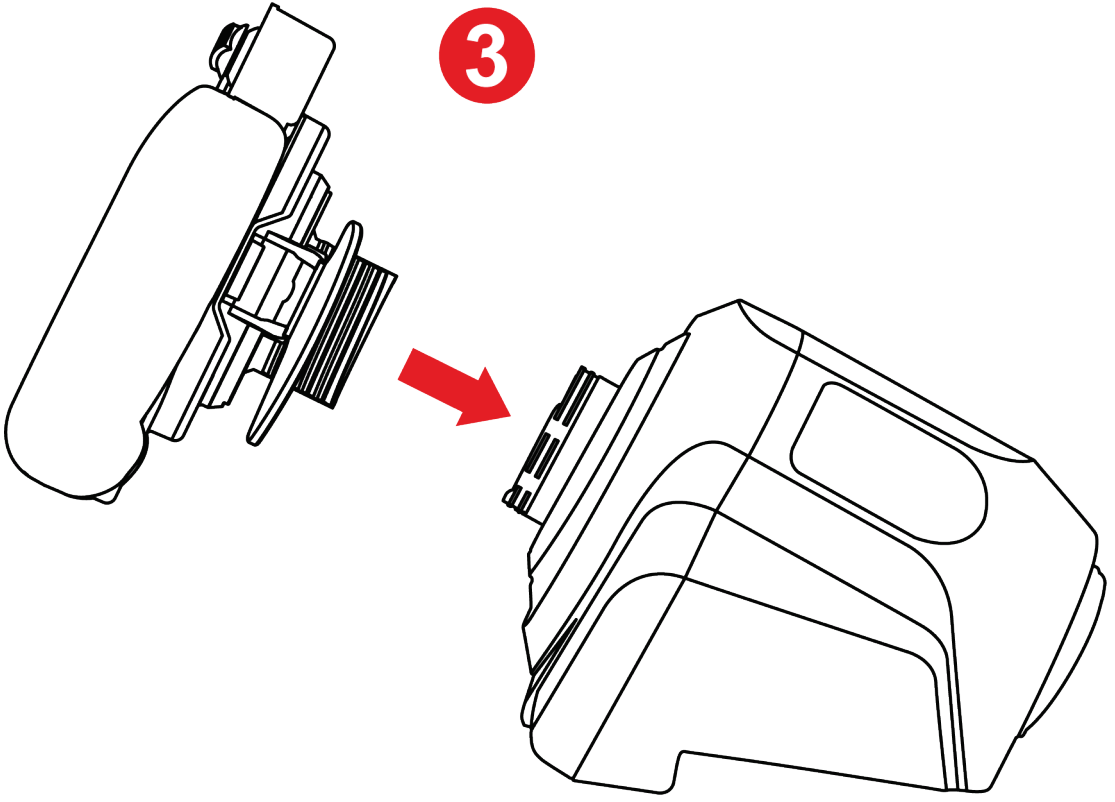

3 휠을 베이스에 장착합니다.



베이스 사용설명서에 제시된 설치 절차를
준수하십시오.



T818 베이스에 사용할 경우 절대 퀵 릴리스 어댑터(T818 베이스와 함께 제공 및 별도 판매)를 나사 베이스 퀵 릴리스 홀더에 연결하지 마십시오.

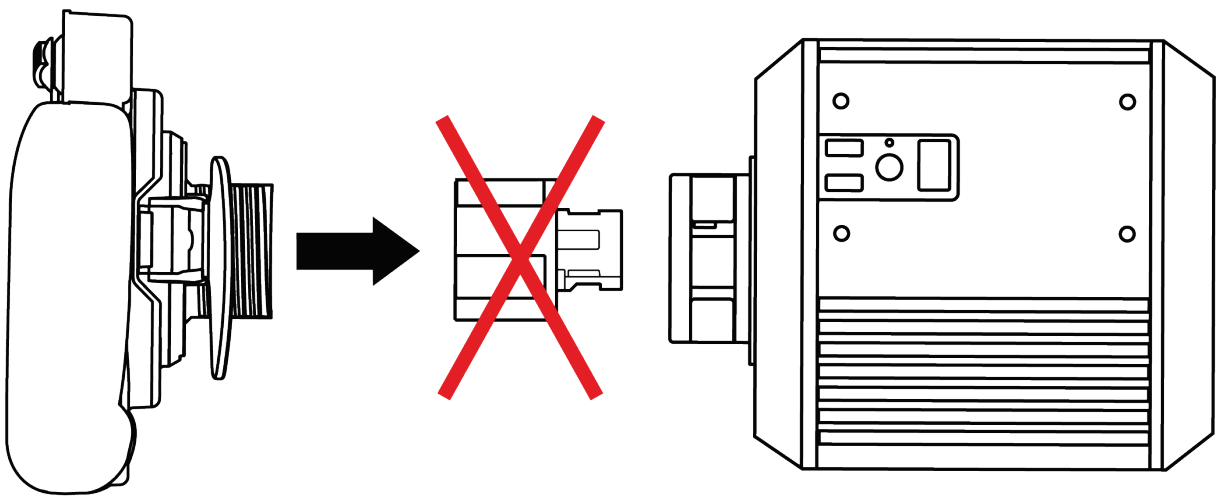
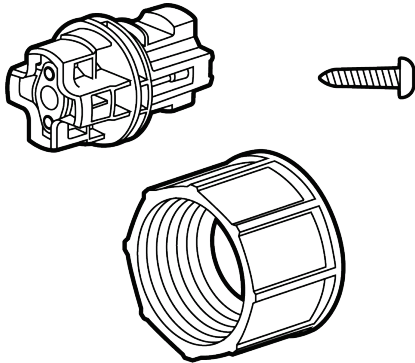

T818 베이스 또는 래치 베이스 커넥터가 장착된 베이스에 사용하려면 **Ferrari 488 GT3 Wheel Add-On** 과 함께 제공된 래치 베이스 퀵 릴리스 홀더만 사용하십시오.



5. 맵핑

PC 용 맵핑

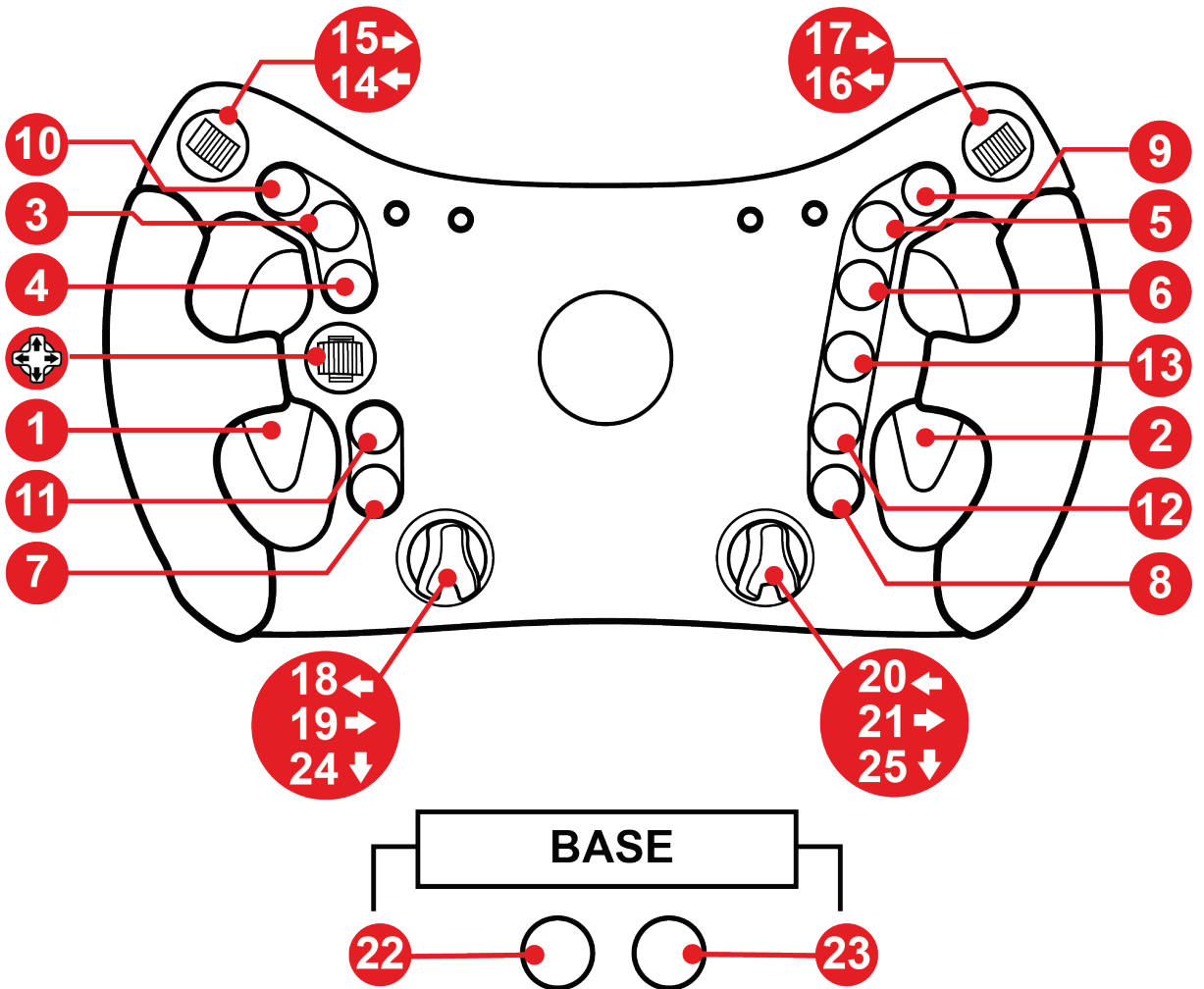



PS4™/PS5™ 용 맵핑

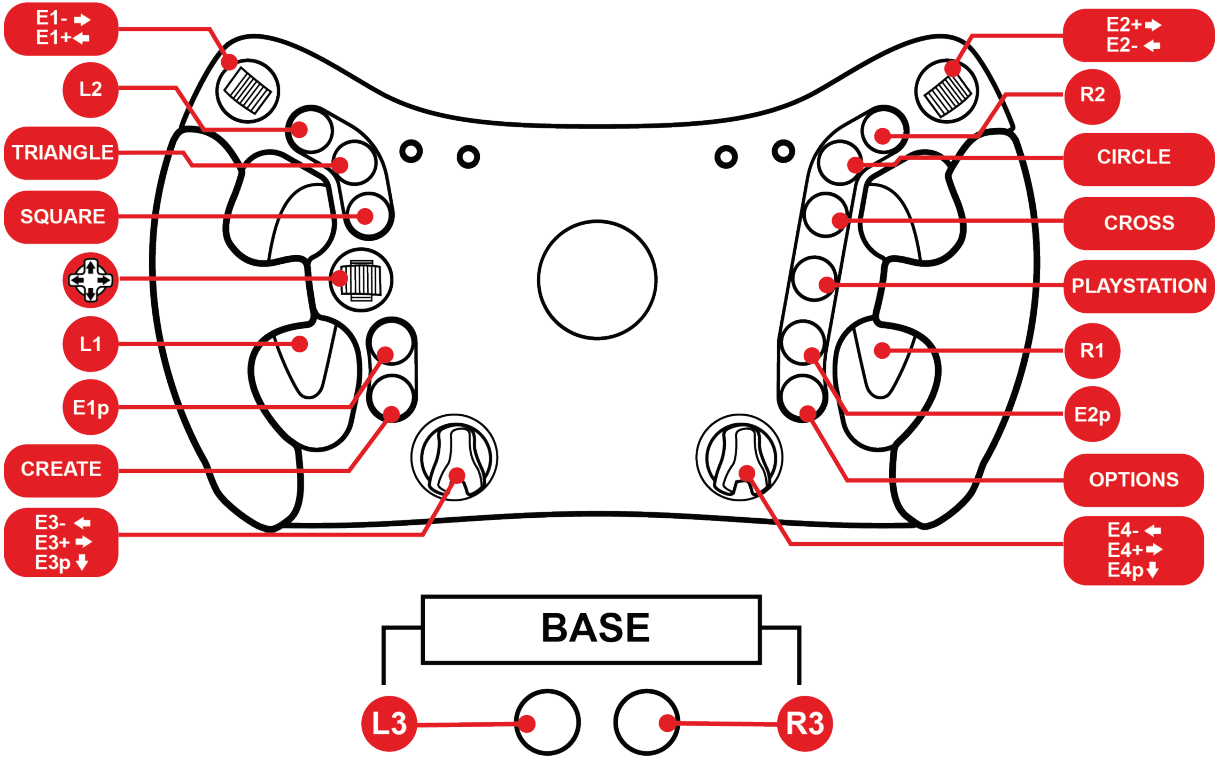



Xbox Series/Xbox One 용 맵핑

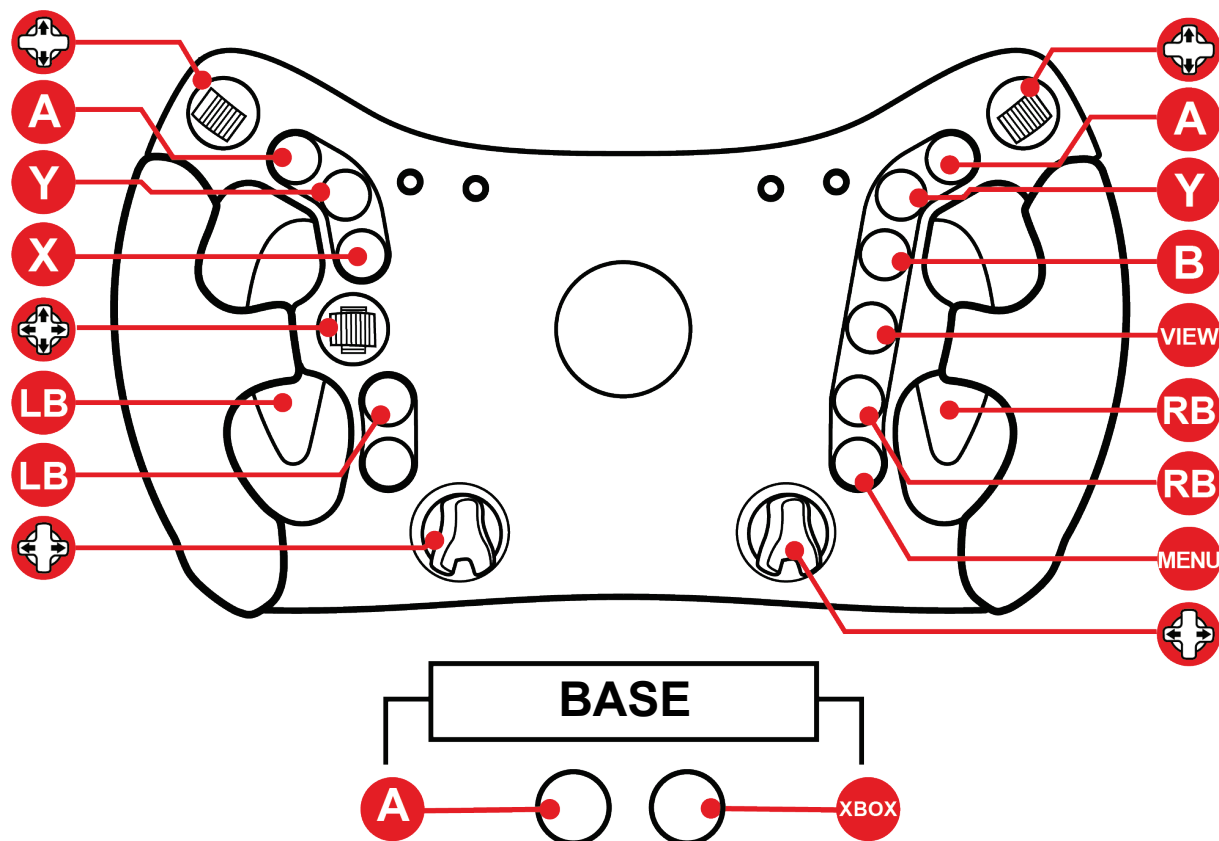

Xbox Series 및 Xbox One 에서:

- 콘솔 프로토콜 제한 때문에 Ferrari 488 GT3 Wheel Add-On 의 LED 가 작동하지 않습니다.
- 일부 기능(인코더, 버튼 수)은 콘솔 프로토콜에 의해 제한됩니다.



6. LED 작동

Ferrari 488 GT3 Wheel Add-On 은 LED 를 통해 플래그, 피트, RPM 등 레이스 데이터를 표시합니다.

모드(GT3 또는 Formula)에 따라 표시되는 데이터를 사용자 정의할 수 있습니다(RPM LED 의 밝기 및 색상).

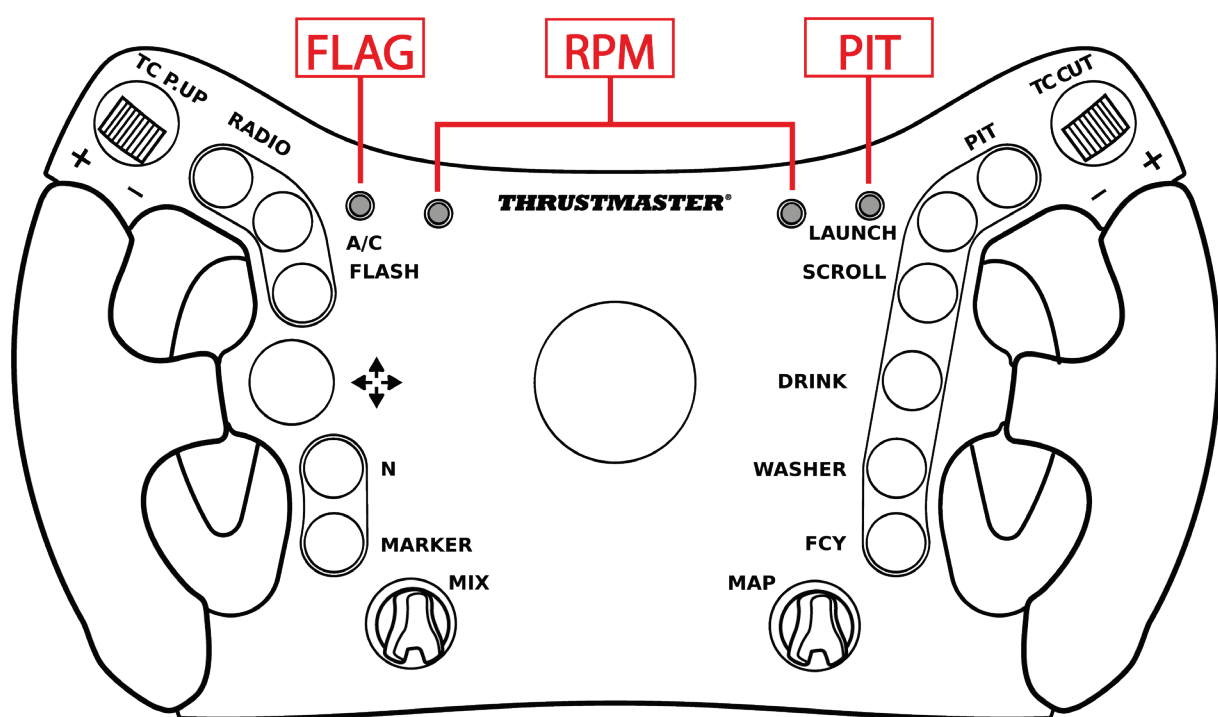

PC 및 PS4™/PS5™에서는 LED 가 작동합니다.

Xbox Series 및 Xbox One에서는 콘솔 프로토콜 제한 때문에 LED 가 작동하지 않습니다.



LED 메뉴 진입/종료 방법

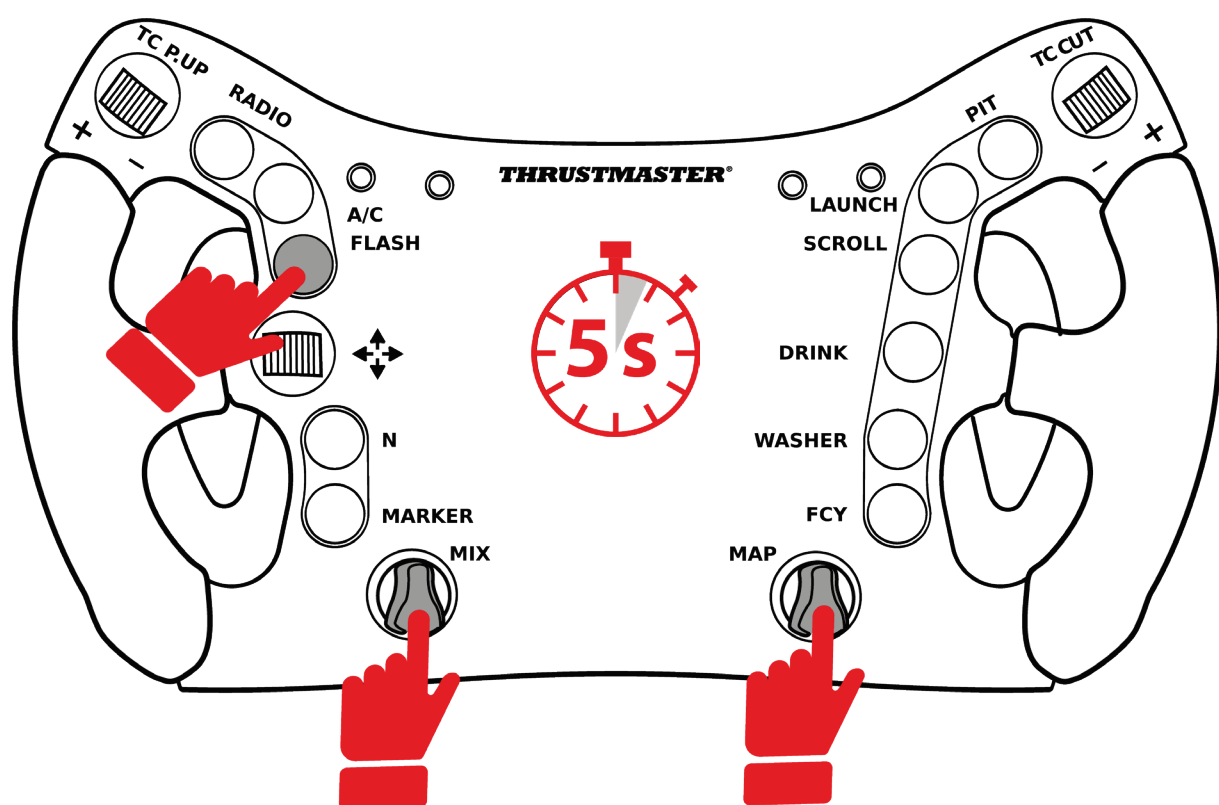

- LED 메뉴에 들어가려면 **FLASH** 버튼과 양쪽 회전 인코더를 **5초간** 동시에 눌렀다 놓습니다.
- LED 메뉴를 종료하려면 **FLASH** 버튼과 양쪽 회전 인코더를 동시에 눌렀다 놓습니다.



FLAG

RPM

PIT



LED 메뉴 진입: FLAG 및 PIT LED 와 RPM LED 중 하나(왼쪽의 빨간색 또는 오른쪽의 파란색)가 켜집니다.



LED 메뉴 종료: LED 4 개가 모두 꺼집니다.



LED 밝기 조절 방법

- **FLASH** 버튼과 양쪽 회전 인코더를 5 초간 동시에 눌렀다 놓아서 LED 메뉴에 들어갑니다.
- 밝기를 낮추려면 왼쪽 인코더(**MIX**)를 왼쪽으로 돌리고 밝기를 높이려면 오른쪽으로 돌립니다.



- **FLASH** 버튼과 양쪽 회전 인코더를 동시에 눌렀다 놓아서 LED 메뉴를 종료합니다.



LED 모드 변경 방법: GT3 또는 Formula

- **FLASH** 버튼과 양쪽 회전 인코더를 5 초간 동시에 눌렀다 놓아서 LED 메뉴에 들어갑니다.
- GT3 모드(빨간색 LED)를 선택하려면 오른쪽 인코더(MAP)를 왼쪽으로 돌리고 Formula 모드(파란색 LED)를 선택하려면 오른쪽으로 돌립니다.



GT3 모드(기본 모드)



FORMULA 모드

- **FLASH** 버튼과 양쪽 회전 인코더를 동시에 눌렀다 놓아서 LED 메뉴를 종료합니다.



7. 패들 시프터 커스터마이제이션

Ferrari 488 GT3 Wheel Add-On 의 패들 시프터는 간격과 도달 거리를 조정할 수 있습니다.

간격은 패들 시프터의 폭을 조정하는 것으로, 그립과 패들 시프터 사이의 거리를 변경합니다.

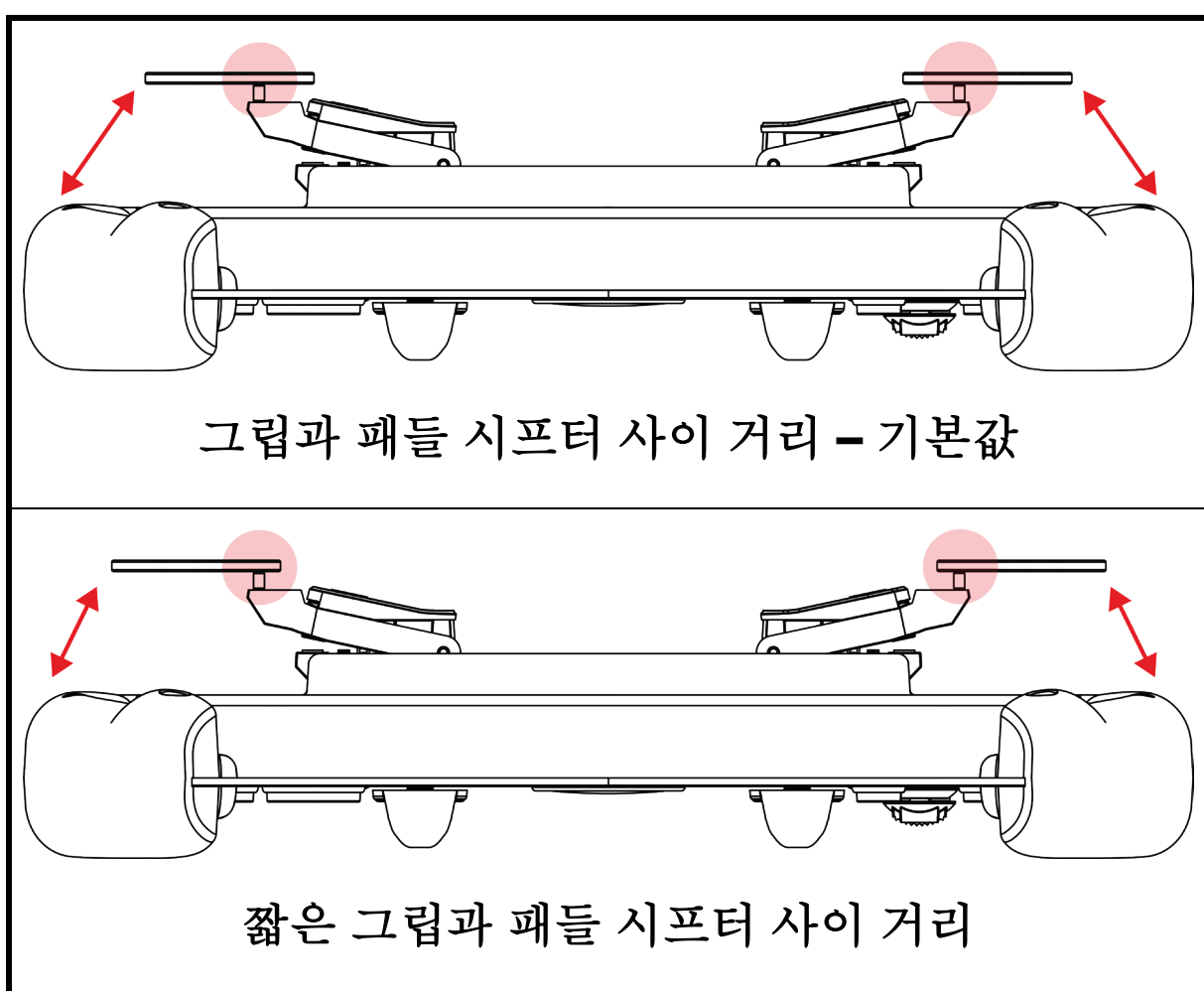



스페이서를 사용해 도달 거리를 조정하면 패들 시프터 작동 거리가 변경됩니다.

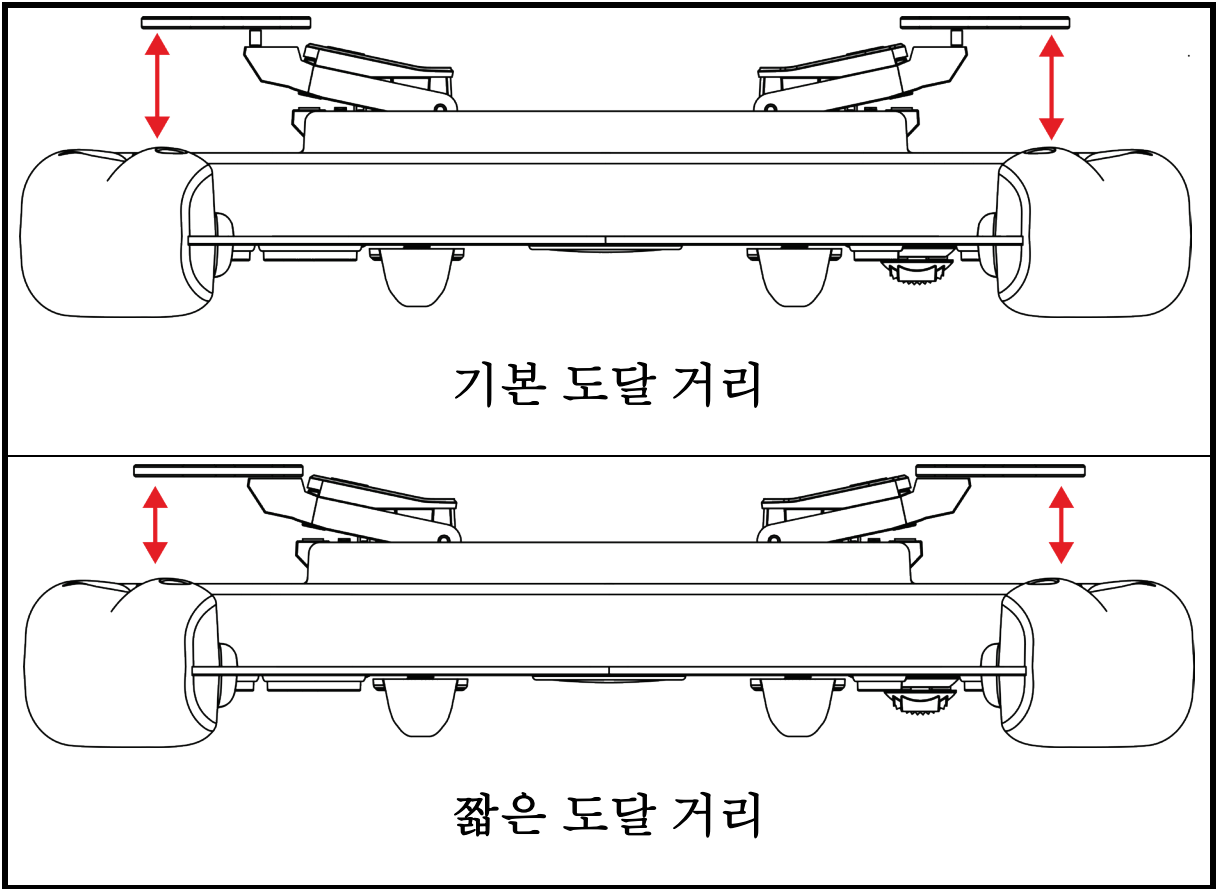

또한, 제공된 패드 세트를 사용하여 패들 시프터가 만들어내는 자기 감도와 사운드 레벨을 조정할 수 있습니다.

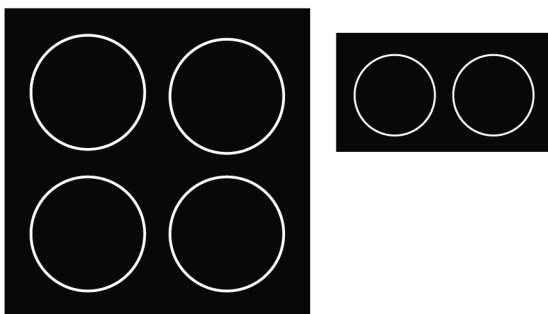



패들 시프터 간격 조정 방법

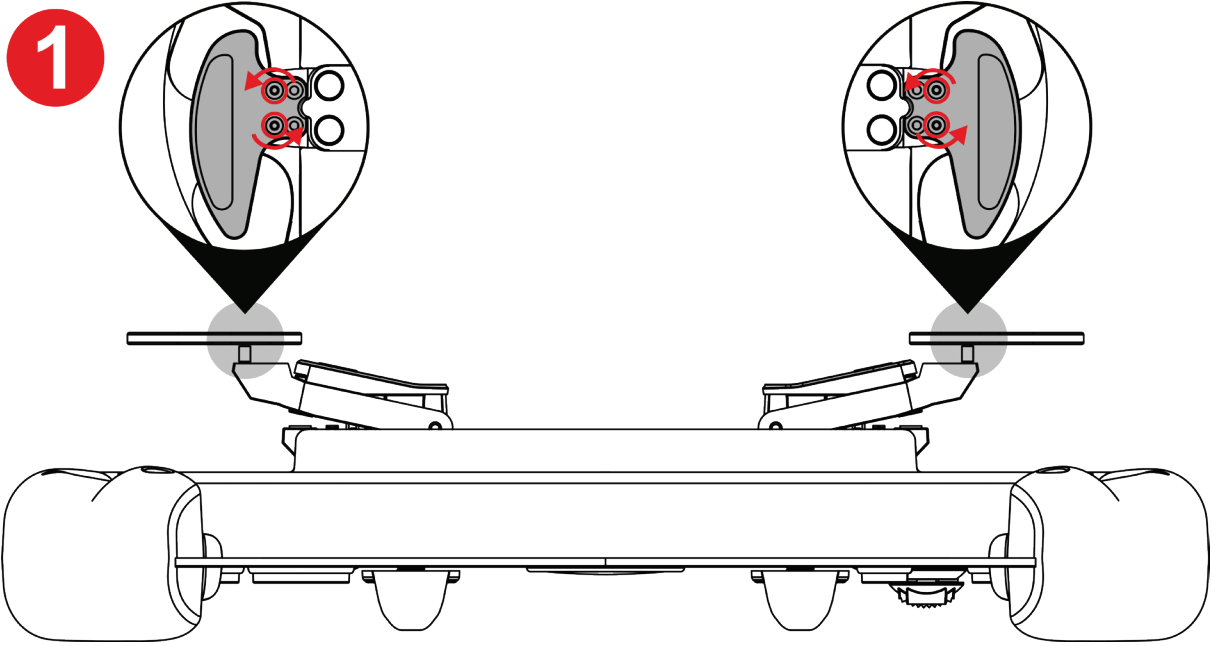

1 제공된 Torx 렌치를 사용하여 패들 시프터 나사 4 개를 풉니다.

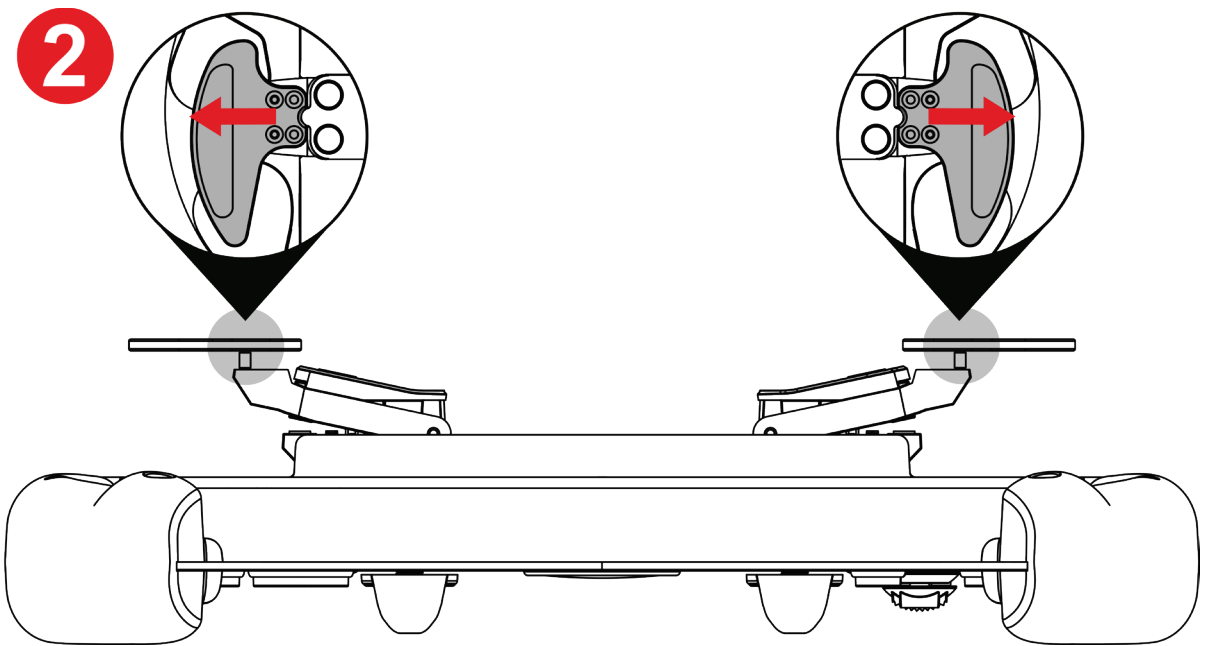

2 패들 시프터를 바깥쪽으로 이동하여 구멍을 맞춥니다.

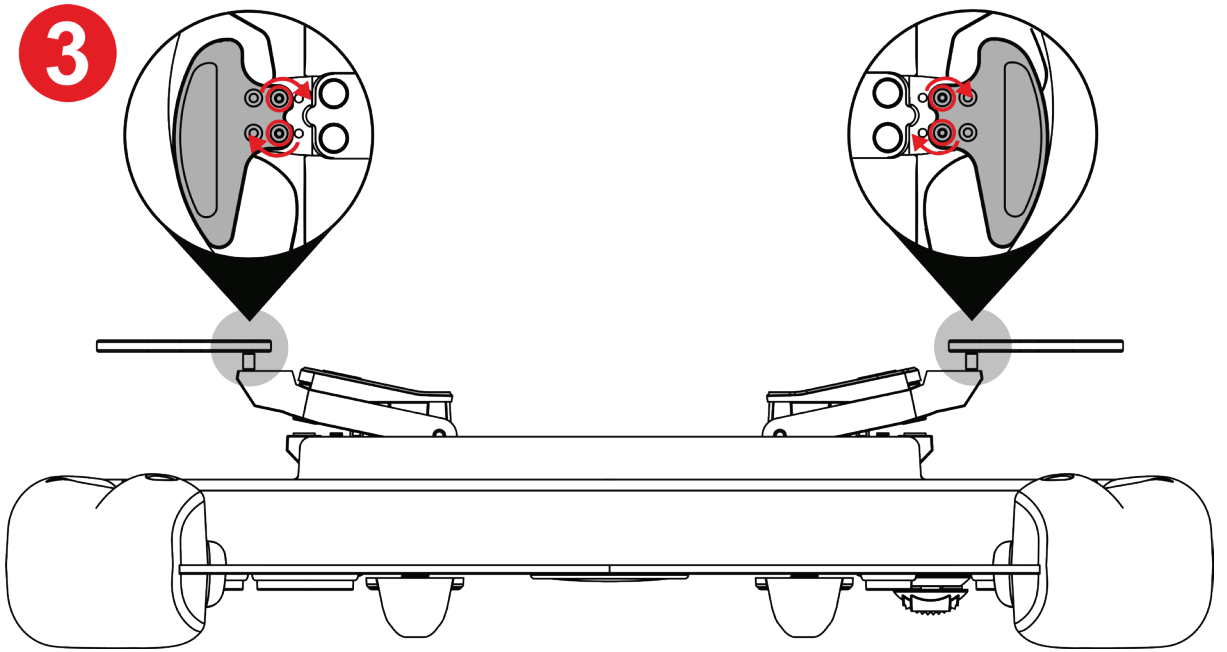

3 제공된 Torx 렌치를 사용하여 페달 시프터 나사 4 개를 조입니다.



패들 시프터 도달 거리 조정 방법

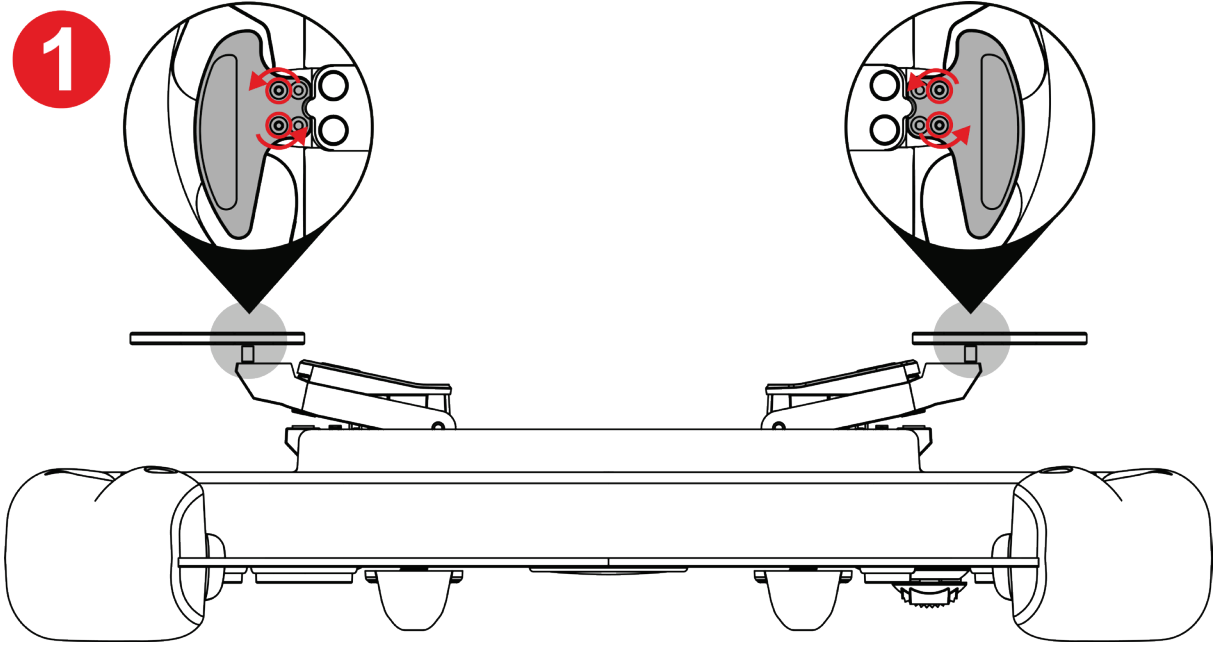

1 제공된 Torx 렌치를 사용하여 패들 시프터 나사 4 개를 풉니다.

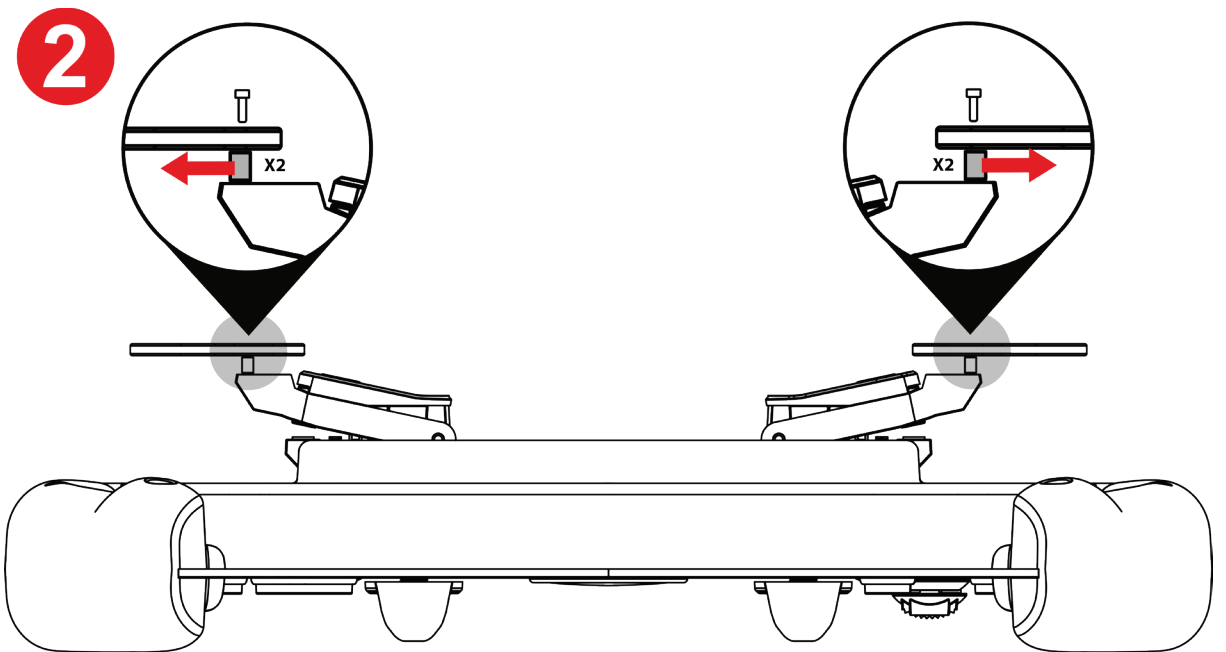

2 스페이서를 분리합니다.

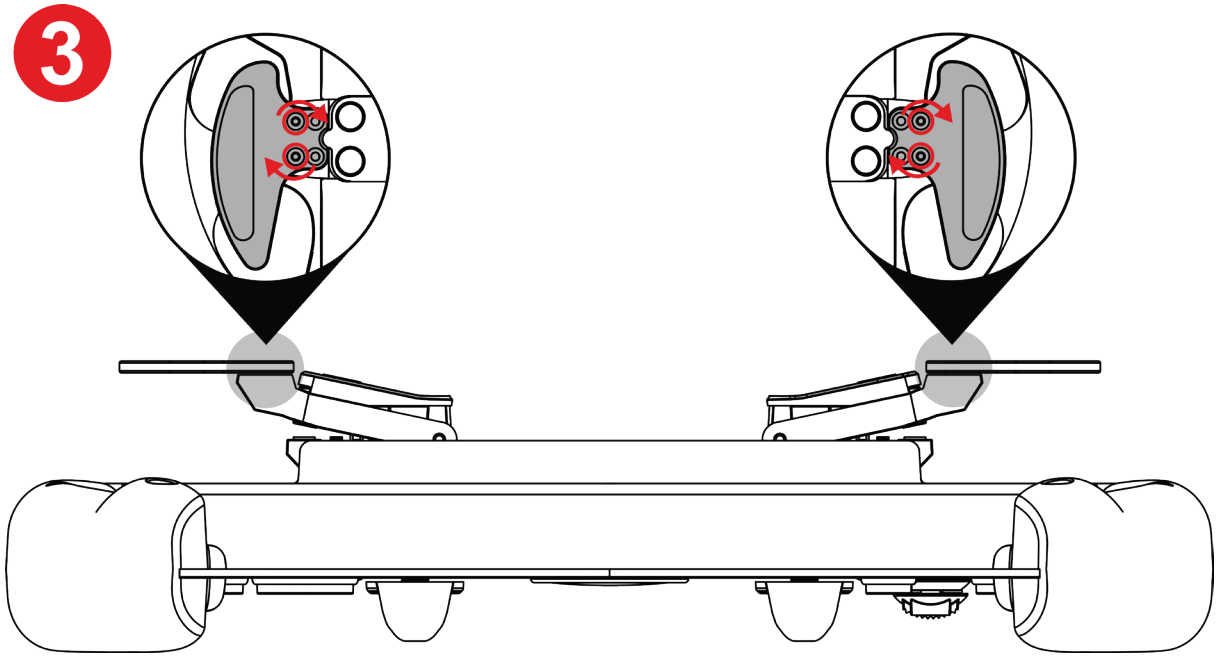

3 제공된 Torx 렌치를 사용하여 페달 시프터 나사 4 개를 조입니다.



패드 시프터의 자기 감도 및 사운드 레벨 조정 방법

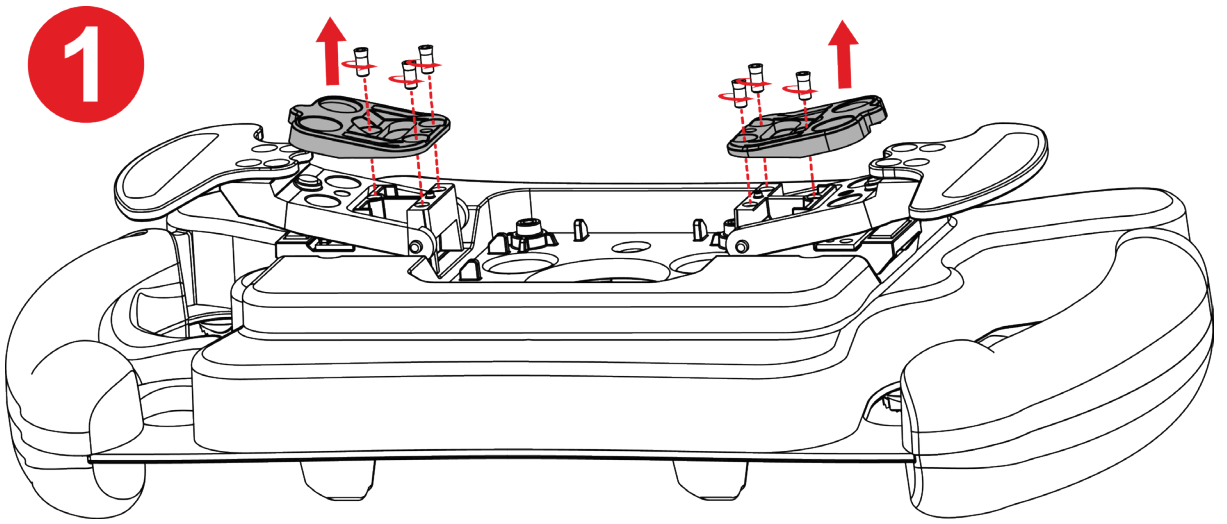

1 제공된 Torx 렌치를 사용해 멈춤 나사 6 개를 풀어 마그네틱 스톱을 분리합니다.

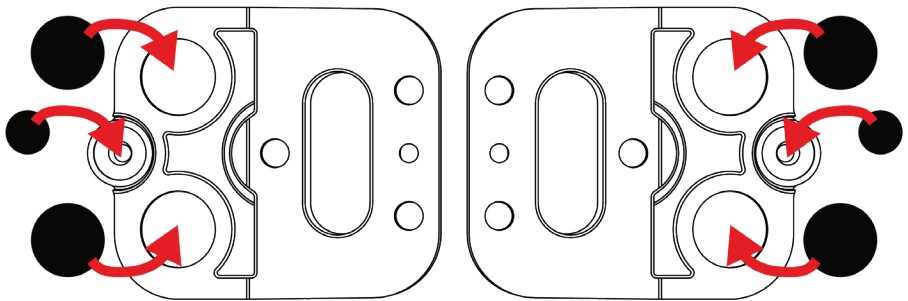
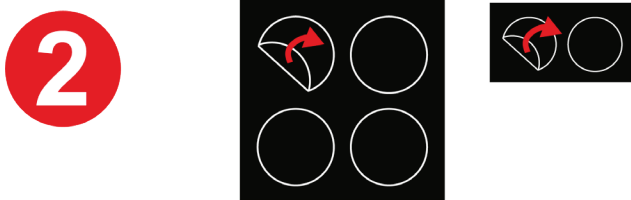

2 제공된 패드를 벗겨 마그네틱 스톱 아래의 적절한 위치에 부착합니다.



가능한 구성 및 그 효과에 대해서는 자기 감도 및 패드 시프터 사운드 감쇠 표를 참조하십시오.



3

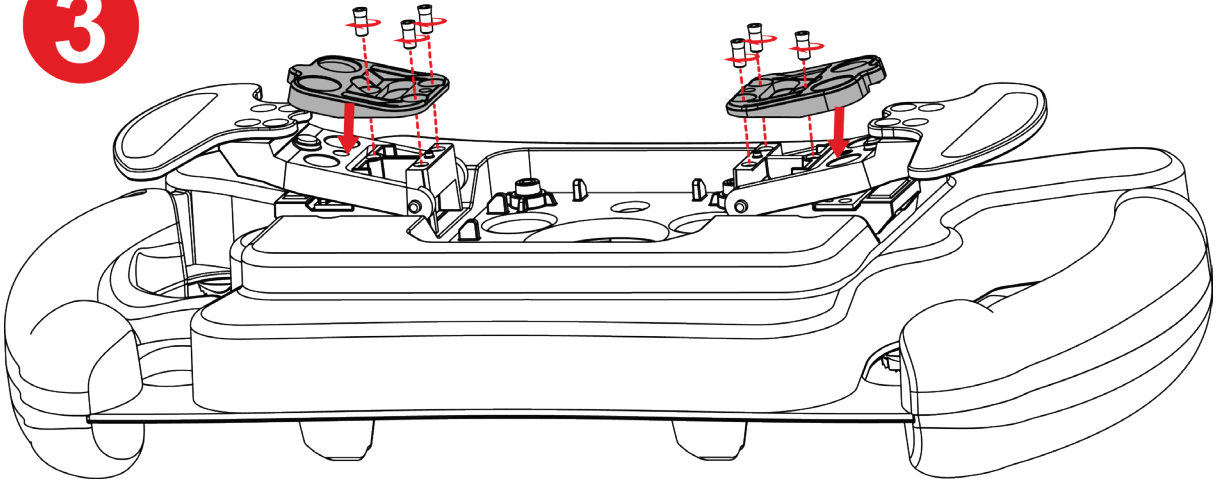

③ 마그네틱 스톱을 다시 설치하고 제공된 Torx 렌치를 사용하여 멈춤 나사 6 개를 조입니다.

자기 감도 및 패들 시프터 사운드 감쇠 표

	<p>(기본값)</p>		
자기 감도			
사운드			



8. 자주 묻는 질문 및 기술 지원

Ferrari 488 GT3 Wheel Add-On 에 관한 질문이 있거나 기술적 문제를 겪고 계신가요? 그런 경우에는 Thrustmaster 기술 지원 웹 사이트를 방문하시기 바랍니다.

<https://support.thrustmaster.com/product/ferrarif488gt3addon>.

이 페이지에서 휠 펌웨어를 업데이트할 수도 있습니다.



THRUSTMASTER®

FERRARI 488 GT3 WHEEL ADD-ON

أجهزة الكمبيوتر الشخصية (Windows 10/11)

PS5™ / PS4™

Xbox One / Xbox Series

دليل المستخدم



اقرأ التعليمات الواردة في هذا الدليل قراءة متأنية وذلك قبل تركيب المنتج وقبل أي استعمال له وقبل إجراء أي صيانة له. وتأكد من اتباع تعليمات السلامة. إذ قد يؤدي عدم اتباع هذه التعليمات إلى وقوع حوادث و/أو أضرار. لذلك، احتفظ بهذا الدليل لكي تتمكن من الرجوع إلى التعليمات في المستقبل.

جدول المحتويات

1. محتويات الصندوق 5
2. الميزات 6
3. معلومات حول استخدام العجلة 8
4. تركيب حامل الإفلات السريع 13
- تركيب حامل الإفلات السريع لقاعدة لسان القفل 14
- تركيب حامل الإفلات السريع لقاعدة المسامير 17
5. المخططات 21
- مخطط أجهزة الكمبيوتر الشخصية 21
- مخطط جهازي PS5™/PS4™ 22
- مخطط Xbox One/Xbox Series 23
6. عمل مصابيح LED 24
- كيفية الدخول/الخروج من قائمة LED 25
- كيفية ضبط شدة إضاءة مصابيح LED 27
- كيفية تغيير وضع مصابيح LED: GT3 أو Formula ... 28

7. تخصيص ناقلي الحركة 29
- 31 كيفية ضبط مسافة ناقل الحركة
- 33 كيفية ضبط اتساع ناقل الحركة
- كيفية ضبط الحساسية المغناطيسية ومستوى الصوت لناقلي
- 35 الحركة
8. الأسئلة الشائعة والدعم الفني 37



FERRARI 488 GT3 WHEEL ADD-ON

كن جزءًا من سباقات GT الأسطورية Ferrari 488 GT3 Wheel Add-On، عجلة مصممة للأداء العالي، ومتوافقة مع جميع قواعد عجلات Thrustmaster.

سيساعدك هذا الدليل في تركيب ملحق Ferrari 488 GT3 Wheel Add-On واستخدامه بأفضل حالة. وقبل بدء السباق، اقرأ التعليمات والتحذيرات قراءة متأنية؛ إذ إنها ستساعدك للتمتع بأقصى متعة يمكن أن يقدمها منتجك.



1. محتويات الصندوق

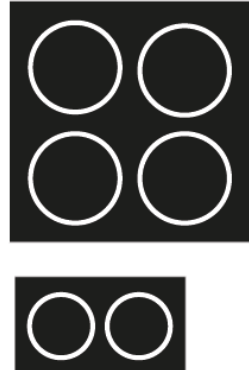
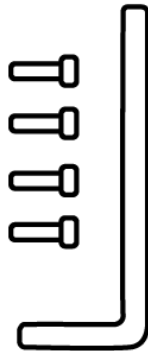
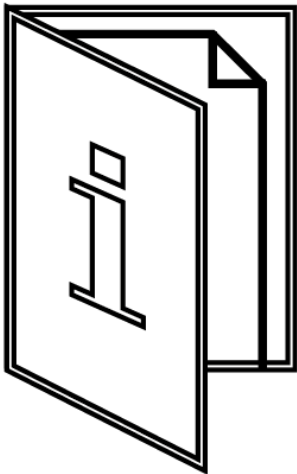
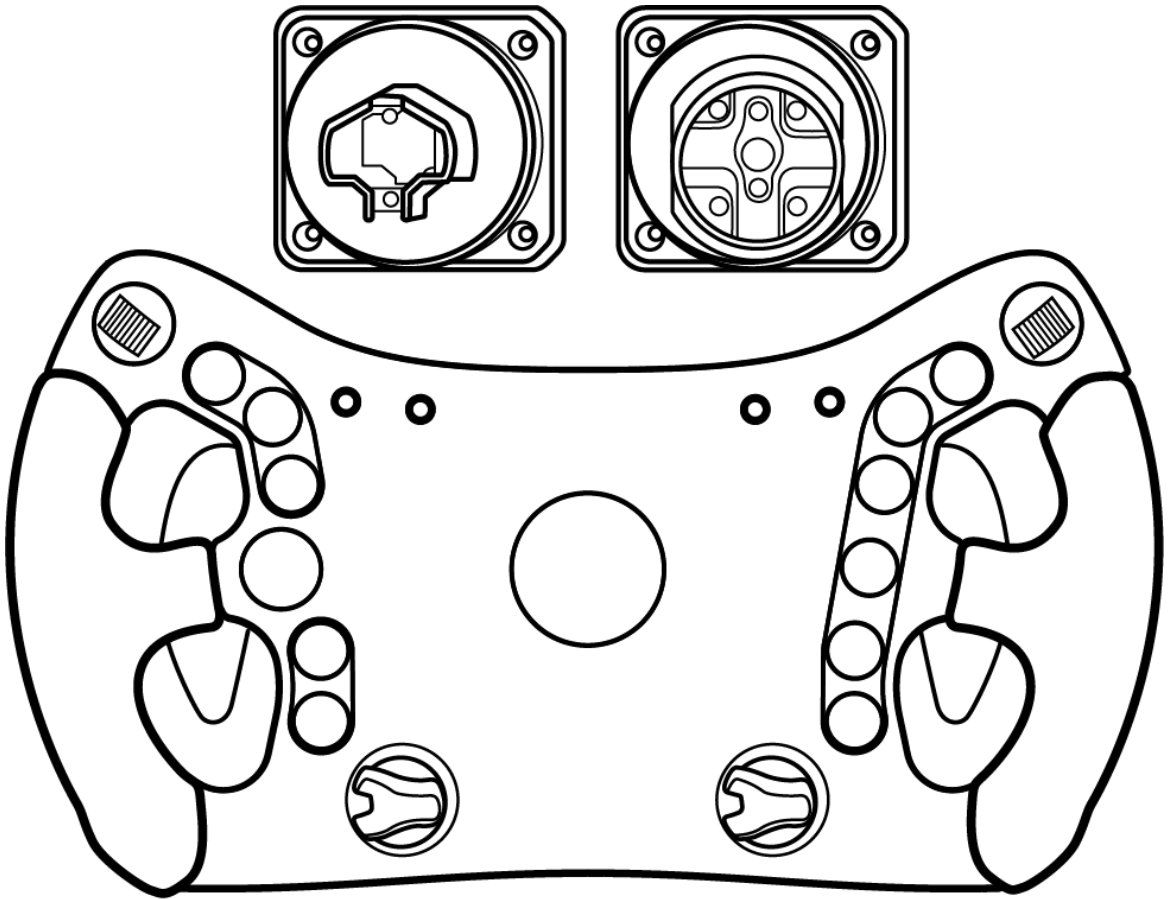

2. الميزات

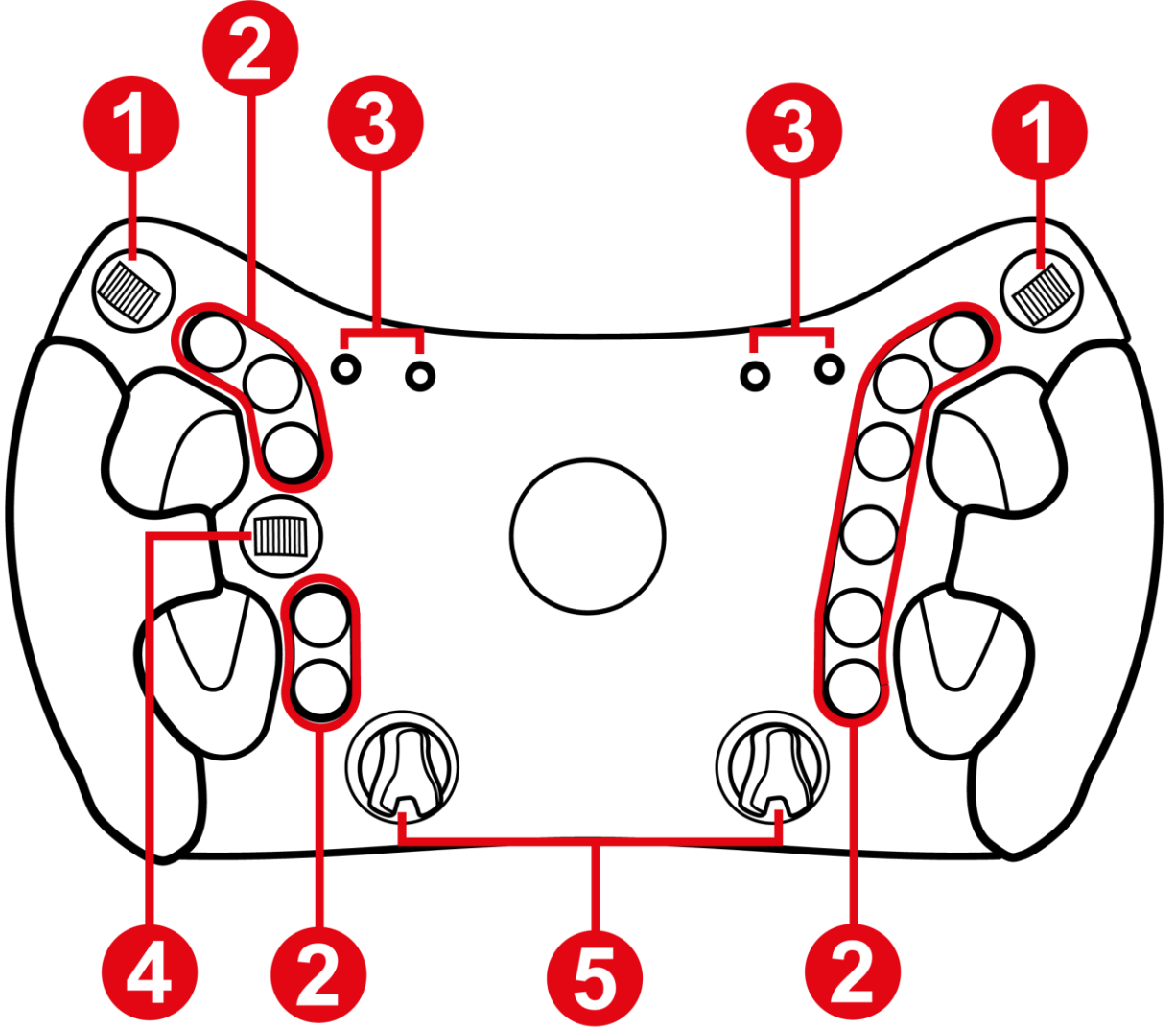

① محول الإبهام

② زر مهام

③ مصابيح LED لعرض سرعة المحرك وبيانات السباق (الأعلام

ومواقف الصيانة)

④ لوحة الاتجاهات

⑤ محولان دواران

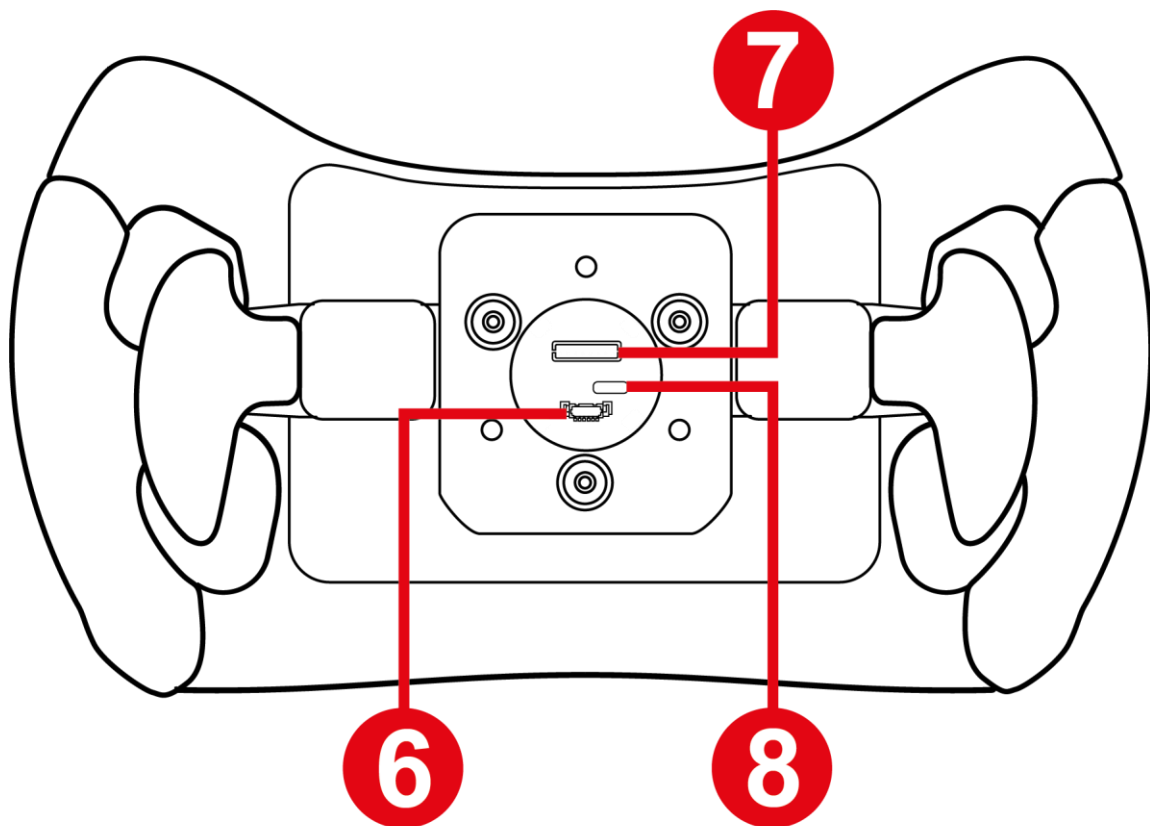

⑥ منفذ توصيل لحامل الإفلات السريع لقاعدة المسامير

⑦ منفذ توصيل لحامل الإفلات السريع لقاعدة لسان القفل

⑧ منفذ USB-C (إذا كان تحديث البرنامج الثابت مطلوبًا - الكابل غير

مضمن)

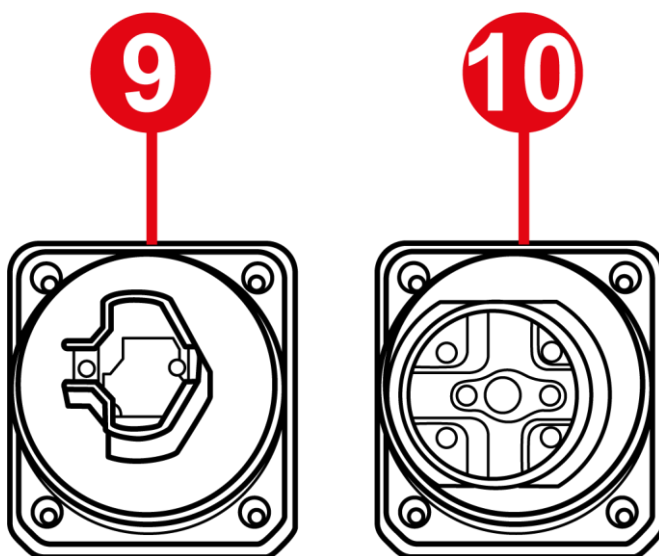

⑨ حامل إفلات سريع لقاعدة لسان القفل

⑩ حامل إفلات سريع لقاعدة المسامير



3. معلومات حول استخدام العجلة



الوثائق

قبل استخدام هذا المنتج، اقرأ هذه الوثيقة قراءة متأنية مرة أخرى، واحتفظ بها للرجوع إليها مستقبلاً.



الصدمة الكهربائية

- احتفظ بالمنتج في مكان جاف ولا تعرّضه للغبار أو لضوء الشمس المباشر.
- لا تقم بثني أو سحب الموصلات أو الكابلات.
- اتبع توجيهات الاتصال.
- لا تسكب أي سائل على المنتج أو توصيلاته.
- لا تُحدِث دائرة قصر كهربائية للمنتج.
- لا تفك المنتج (إلا في حالات التخصيص الموضحة في هذا الدليل)؛ ولا تلقه في النار، ولا تعرّضه لدرجات حرارة مرتفعة.
- لا تفتح الجهاز: فلا توجد أجزاء داخله يمكن للمستخدم صيانتها بنفسه. ويجب تنفيذ أي إصلاحات بواسطة الشركة المصنّعة، أو وكالة معتمدة، أو فني مؤهل.



تأمين منطقة اللعب

- لا تضع في منطقة اللعب أي شيء قد يربك المستخدم أثناء استخدامه للجهاز، أو قد يثير حركة غير مناسبة أو مقاطعة من جانب شخص آخر (فنجان قهوة، أو هاتف، أو مفاتيح، على سبيل المثال).
- لا تغطّ كابلات الطاقة بسجادة أو فرش أو بطانية أو غطاء أو أي مصنوعات أخرى، ولا تضع أي كابلات في مكان يسير الأشخاص فيه.



الإصابات بسبب رد الفعل الاهتزازي والحركات المتكررة

قد يتسبب استخدام عجلة قيادة سباق تشتمل على رد فعل اهتزازي في حدوث آلام بالعضلات أو المفاصل. ولتفادي أي مشكلات:

- قم بالإحماء مسبقًا، وتجنب استخدام القاعدة لفترات طويلة.
- استرح لمدة تتراوح بين 10 دقائق و15 دقيقة بعد كل ساعة استخدام.
- إذا شعرت بأي إرهاق أو ألم في يديك أو معصميك أو ذراعيك أو قدميك أو ساقيك، فاضغط على الزر المخصص لإيقاف تشغيل رد الفعل الاهتزازي وأوقف تشغيل القاعدة والراحة لبضع ساعات قبل بدء استخدام القاعدة مرة أخرى.

- إذا استمرت الأعراض أو الآلام المُشار إليها بالأعلى عند بدء استخدام القاعدة مرة أخرى، توقف عن استخدامها واستشر طبيبك.

- لا تقم بتعيين رد الفعل الاهتزازي على مستوى مرتفع للغاية بالمقارنة مع خبرتك وحالتك البدنية.

- احتفظ بالجهاز بعيدًا عن متناول الأشخاص الذين تقل أعمارهم عن 16 عامًا.

- تأكد من تثبيت القاعدة وعجلة القيادة بشكل صحيح، وفق تعليمات الدليل.



خطر حدوث لفات غير متوقعة وقوية وسريعة: لا تضع أبدًا يديًا أو ذراعًا خلال الفتحات الموجودة في إطار عجلة القيادة أو في مسار دوران العجلة.

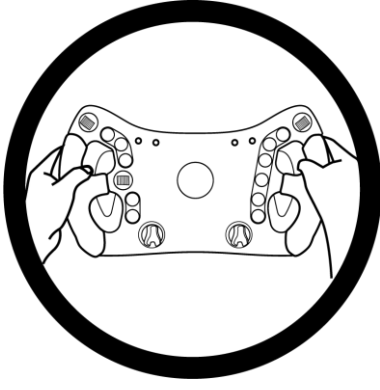

عند استخدام المنتج، حافظ على بقاء كلتا يديك دائمًا في الوضع الصحيح على عجلة القيادة دون حتى رفعهما تمامًا.



لا يجوز التعامل مع المنتج إلا من قبل أشخاص تبلغ أعمارهم 16 عامًا أو أكثر.

4. تركيب حامل الإفلات السريع

يتوفر **Ferrari 488 GT3 Wheel Add-On** بحاملين للإفلات السريع يتوافقان مع التنسيقات الأساسية لـ Thrustmaster.

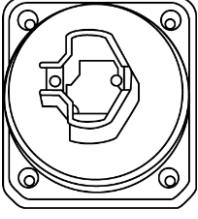
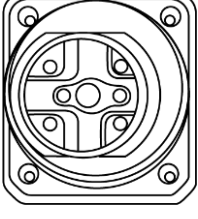
نظام	التوافق
 <p>حامل إفلات سريع لقاعدة لسان القفل</p>	T818 Ferrari SF1000 ,T818 Thrustmaster Simulator وقواعد المستقبلية.
 <p>حامل إفلات سريع لقاعدة المسامير</p>	T-GT / T-GT II Servo Base و TS PC و T300 RS Servo Base و TX Racing و TS-XW و Racer و Wheel Servo Base و TS-XW و Servo Base.



قبل كل استخدام، تأكد من **Ferrari 488 GT3 Wheel Add-On** لا يزال مثبتاً بشكل صحيح في الدعامة، وفق تعليمات الدليل الخاصة بالقاعدة.



تركيب حامل الإفلات السريع لقاعدة لسان القفل

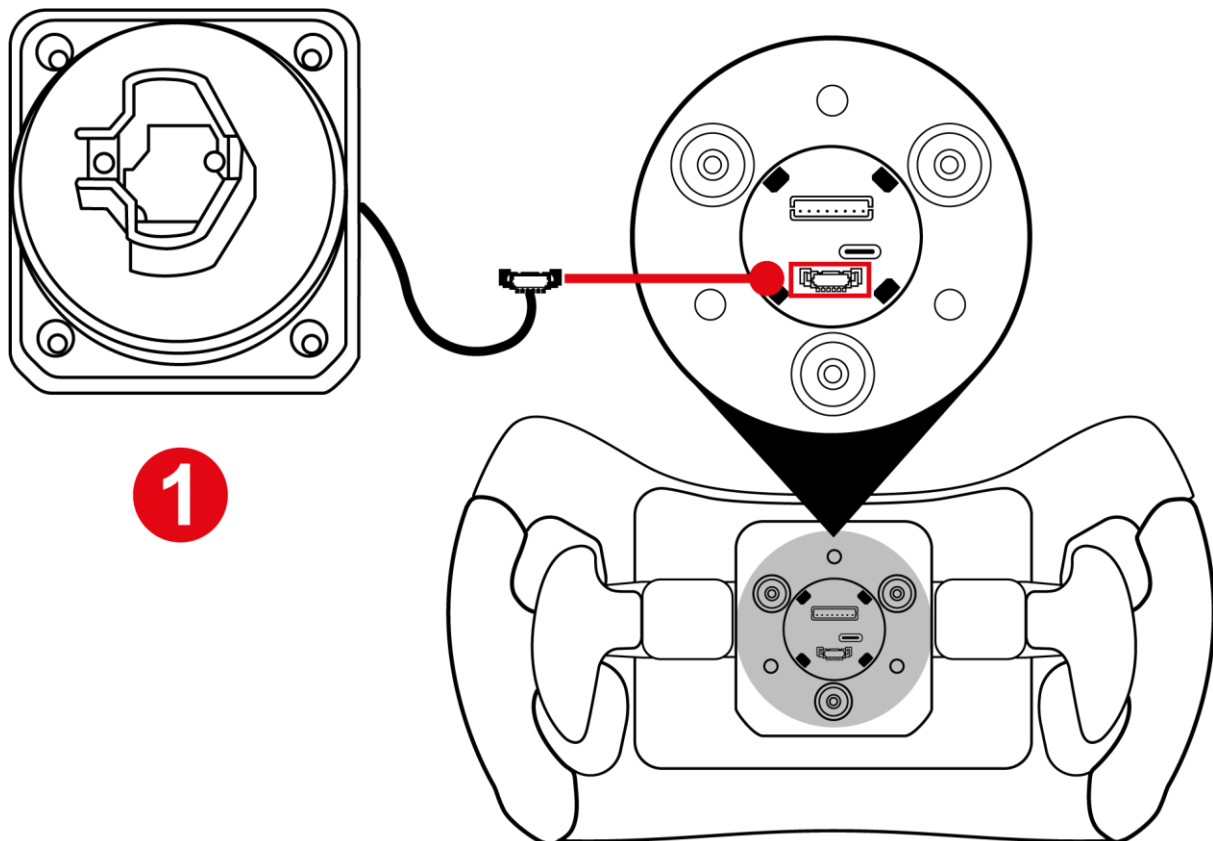

1

1 صل موصل حامل الإفلات السريع بالمنفذ المقابل الموجود في الجزء الخلفي من العجلة.



لتجنب الضغط على الكابل، اسحبه إلى داخل غلافه قبل ربط الحامل.

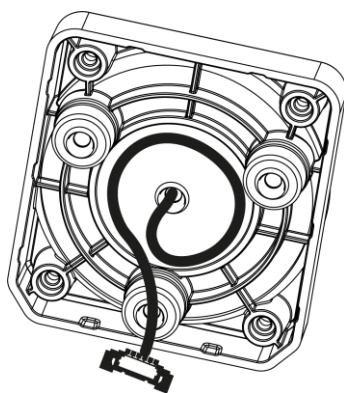

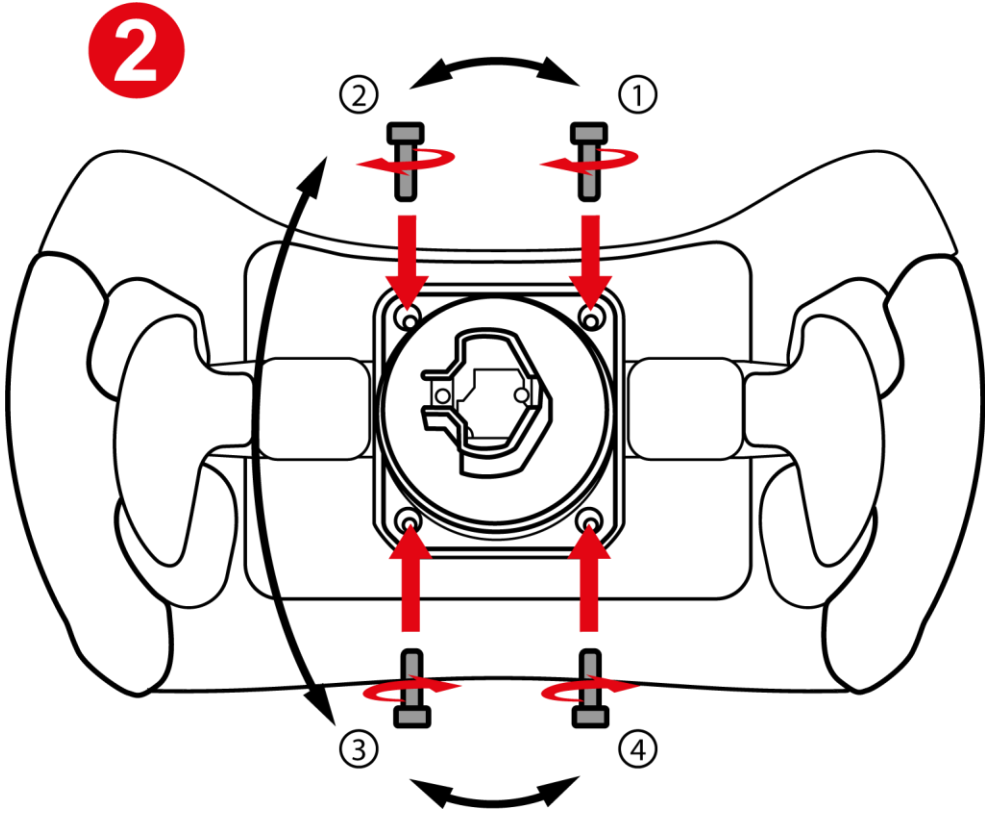

② أدخل حامل الإفلات السريع وأحكم ربطه باستخدام المفك السداسي المرفق.



عند تركيب الحامل، لا تتبالغ في ربط المسامير.

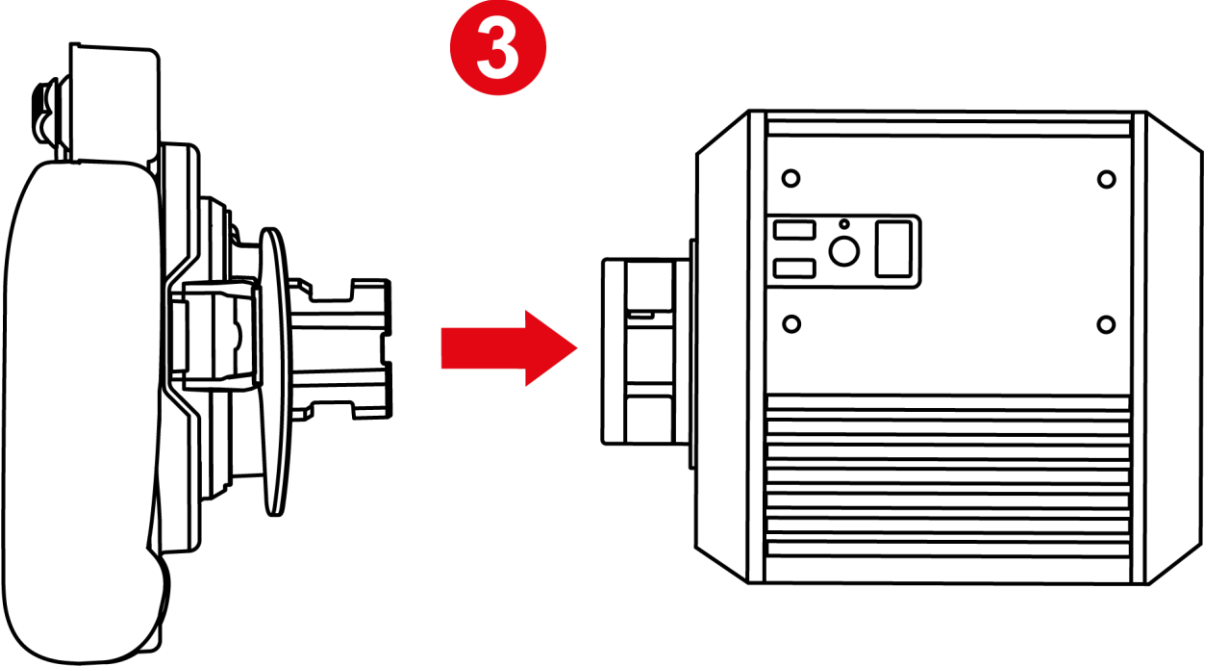

3 ثبّت العجلة على القاعدة.



اتبع إجراء التركيب المحددة في دليل المستخدم الخاص بالقاعدة.

تركيب حامل الإفلات السريع لقاعدة المسامير

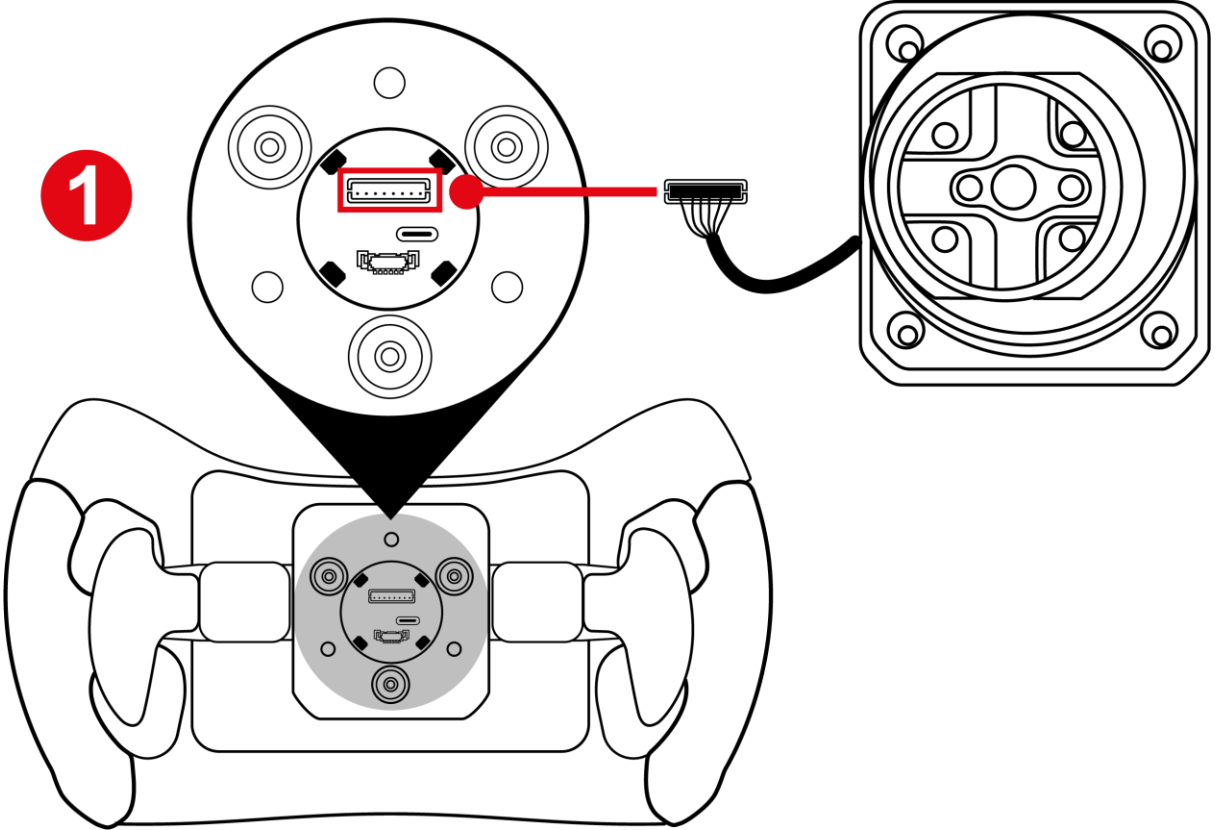

1 صل موصل حامل الإفلات السريع بالمنفذ المقابل الموجود في الجزء الخلفي من العجلة.



لتجنب الضغط على الكابل، اسحبه إلى داخل غلافه قبل ربط الحامل.

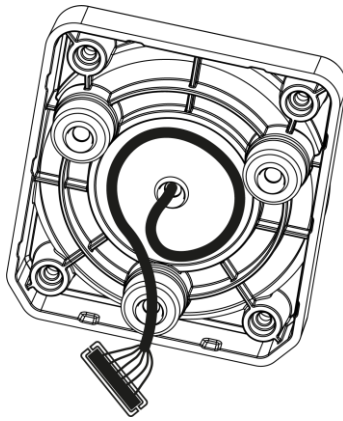

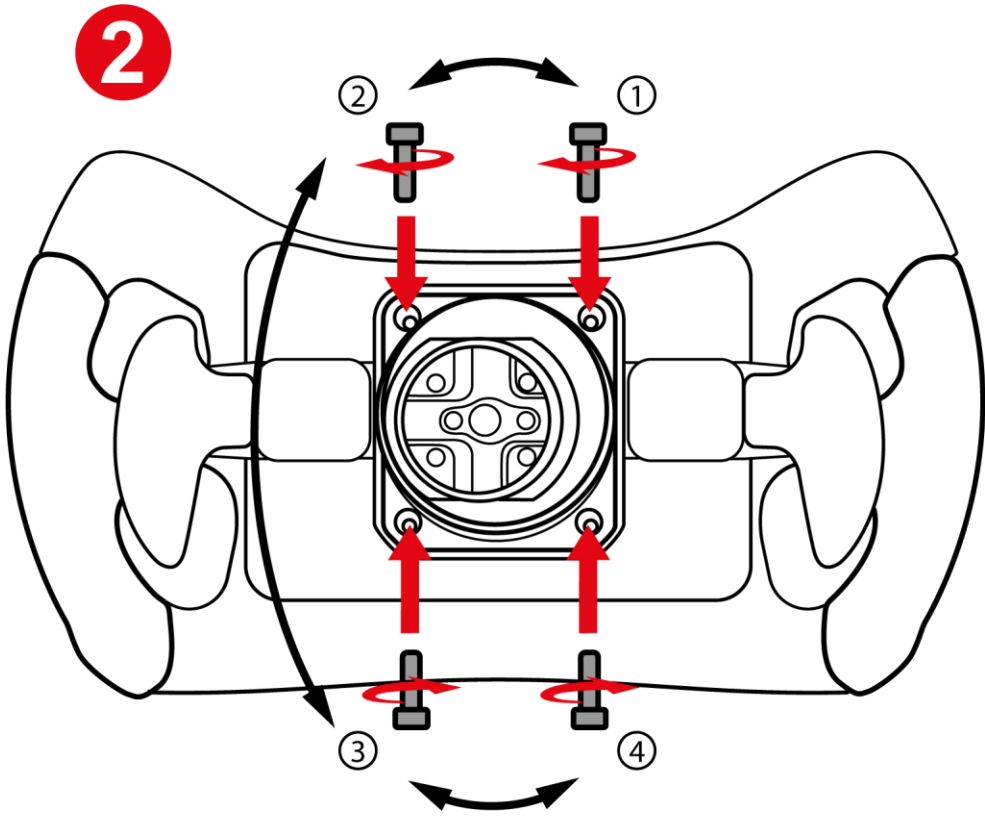

② أدخل حامل الإفلات السريع وأحكم ربطه باستخدام المفك السداسي المرفق.



عند تركيب الحامل، لا تتبالغ في ربط المسامير.

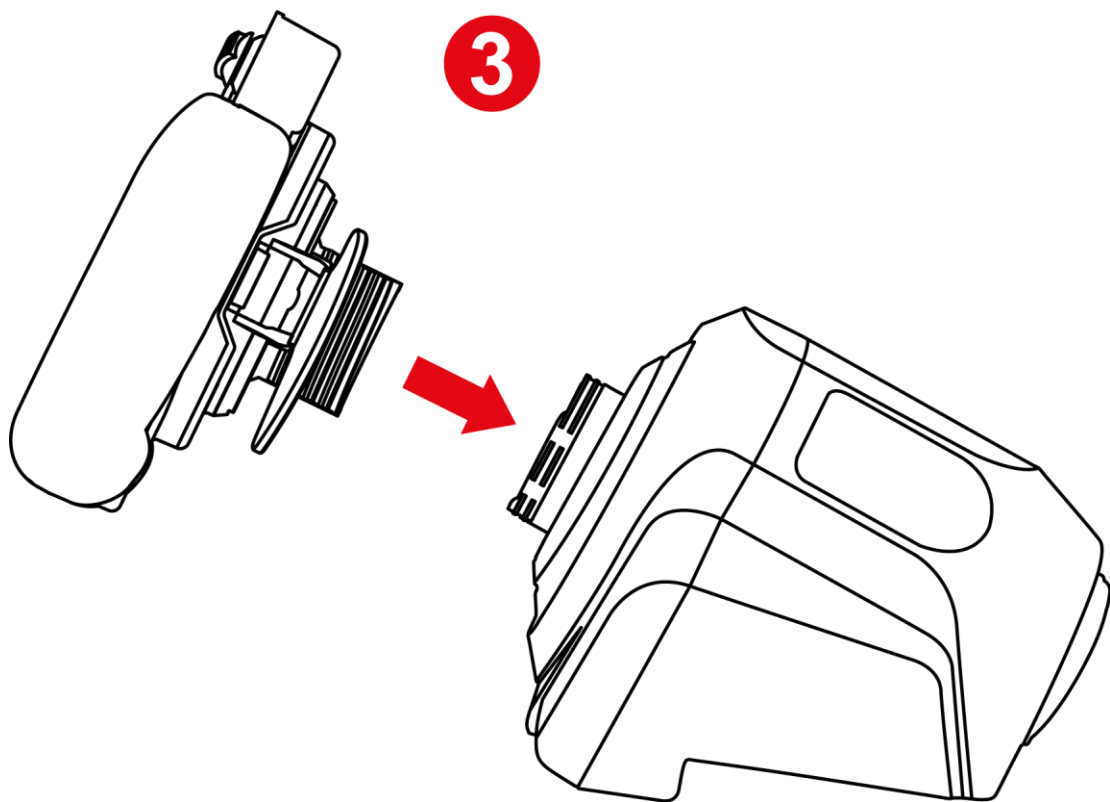

3 ثبّت العجلة على القاعدة.



اتبع إجراء التركيب المحددة في دليل المستخدم الخاص بالقاعدة.



لا توصل أبدًا محول Quick Release Adapter (المرفق مع قاعدة T818 وبياع بشكل منفصل) بحامل الإفلات السريع لقاعدة المسامير إذا كنت تنوي استخدامه على قاعدة T818.

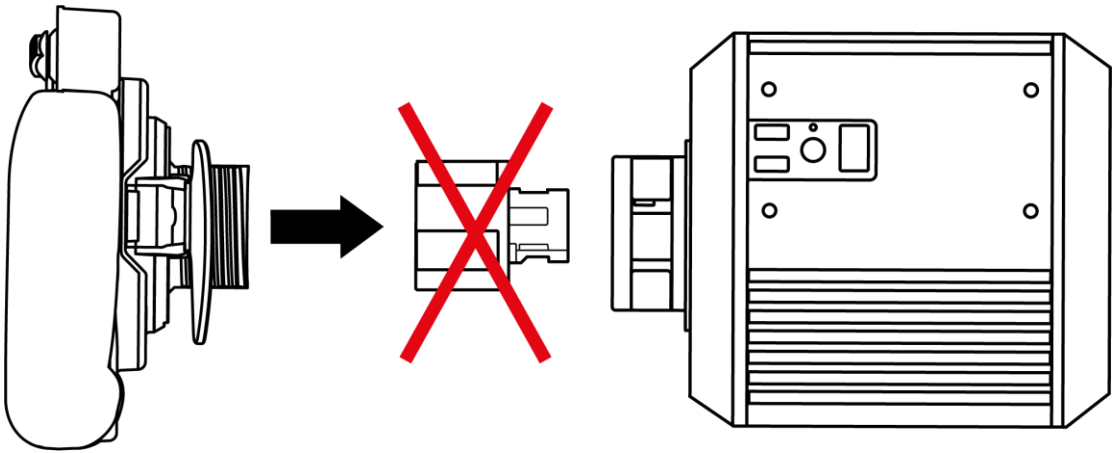
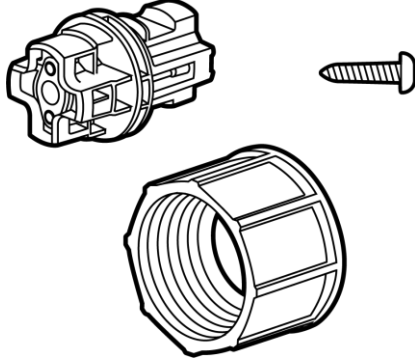

للاستخدام على قاعدة T818 أو قاعدة مجهزة بموصل لقاعدة لسان القفل،
استخدم فقط حامل الإفلات السريع لقاعدة لسان القفل المرفق مع Ferrari
488 GT3 Wheel Add-On.



5. المخططات

مخطط أجهزة الكمبيوتر الشخصية

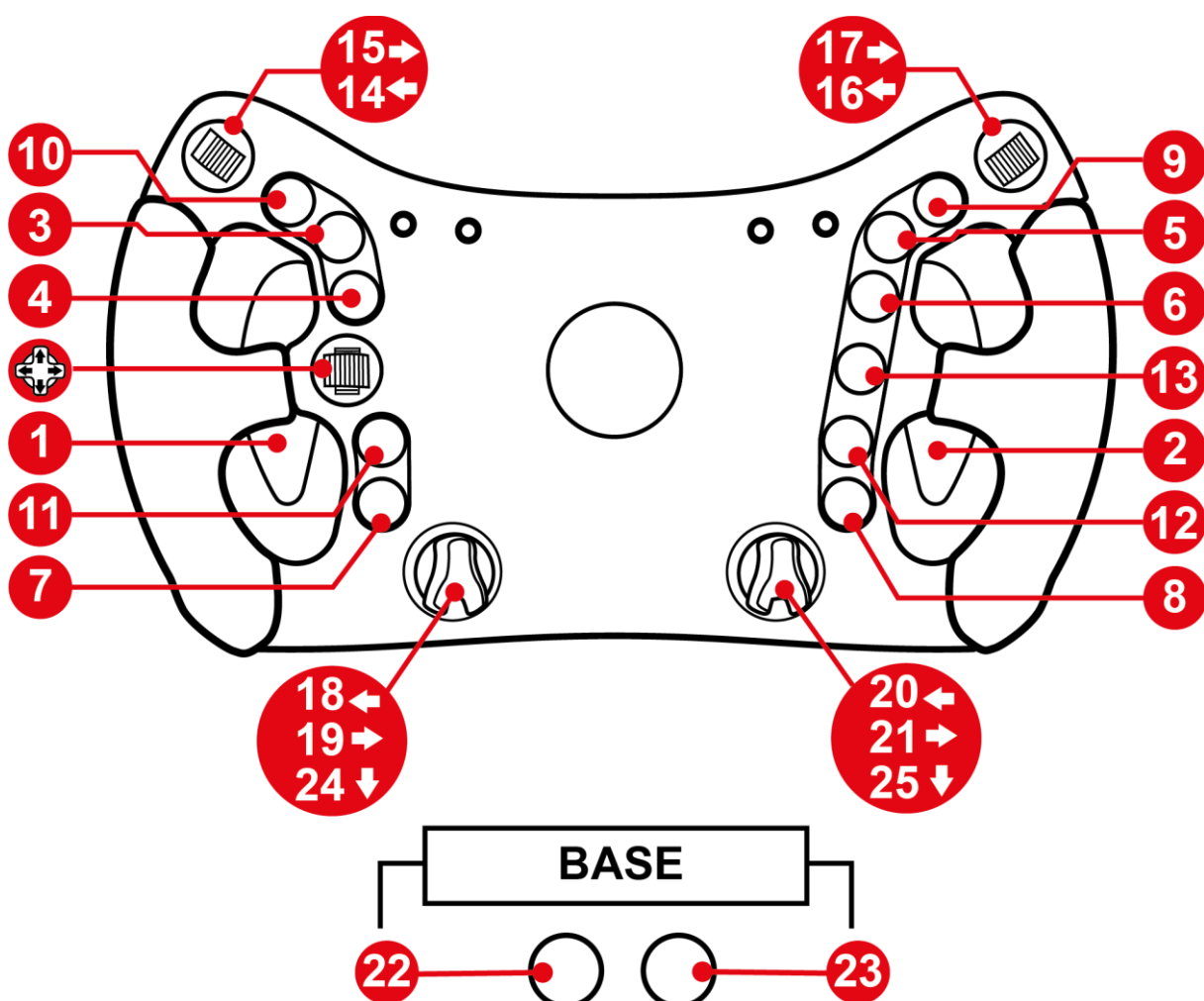



مخطط جهازي PS5™/PS4™

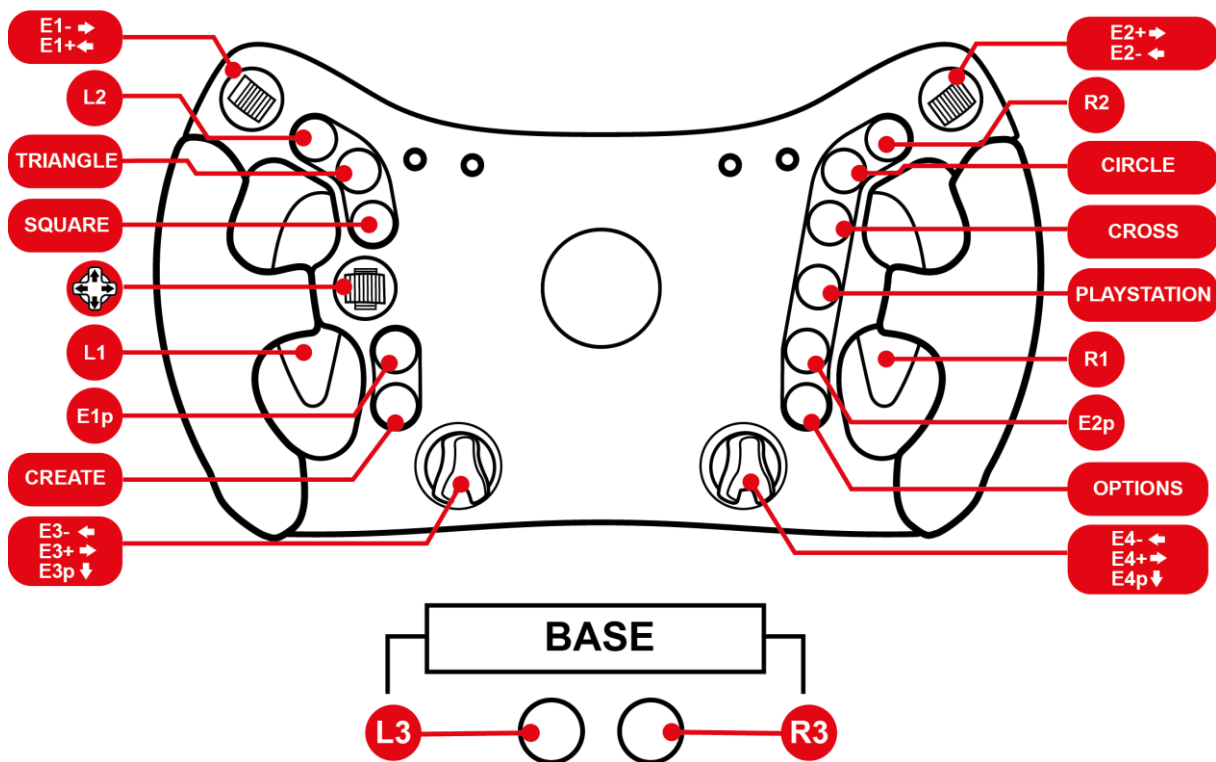



مخطط Xbox One/Xbox Series

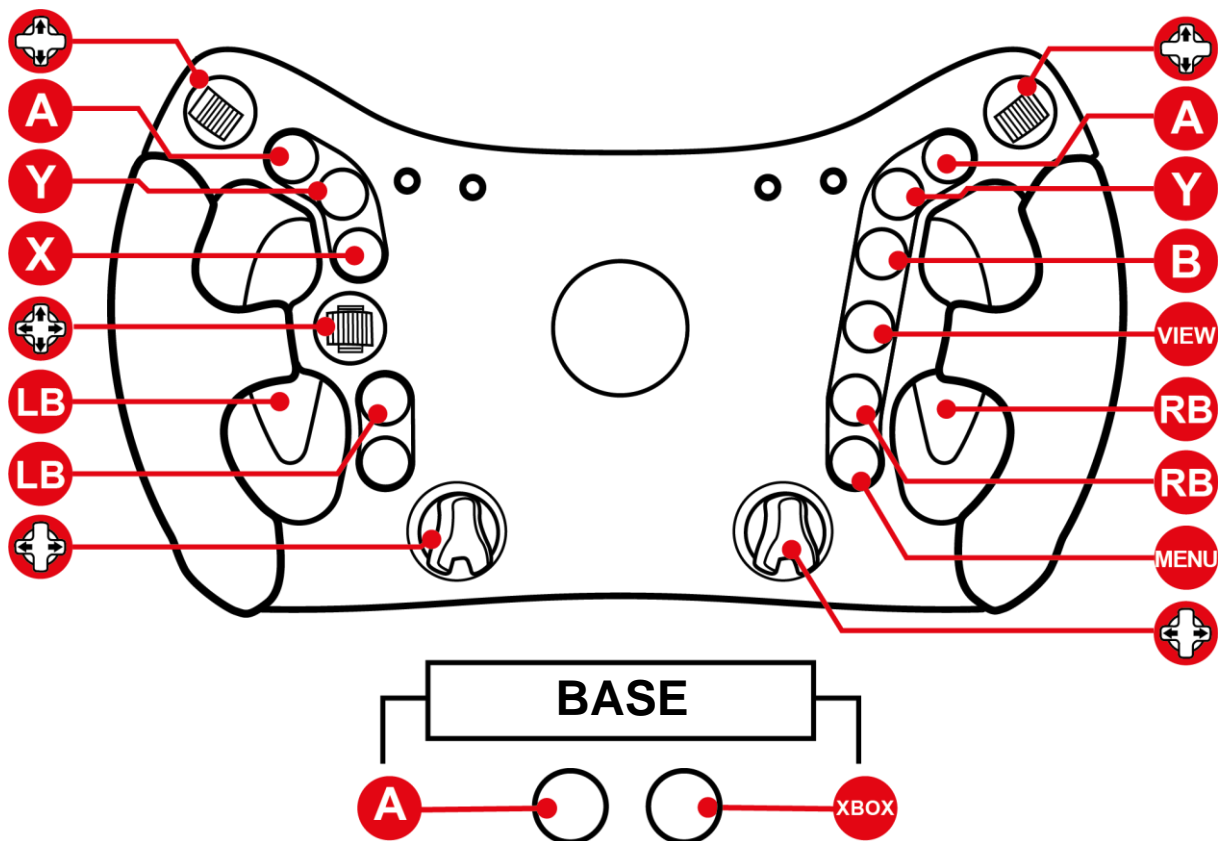

على Xbox One و Xbox Series:

- لا تعمل مصابيح LED الموجودة في Ferrari 488 GT3 Wheel Add-On بسبب قيود بروتوكول الجهاز.
- تكون بعض الوظائف (المحولات، عدد الأزرار) محدودة بسبب بروتوكول الجهاز.

6. عمل مصابيح LED

يعرض **Ferrari 488 GT3 Wheel Add-On** بيانات السباق عبر مصابيح LED: العلم ومواقف الصيانة وسرعة المحرك. يمكن تخصيص البيانات المعروضة (لون مصابيح LED لسرعة المحرك وشدة إضاءتها)، حسب الوضع (GT3 أو Formula).

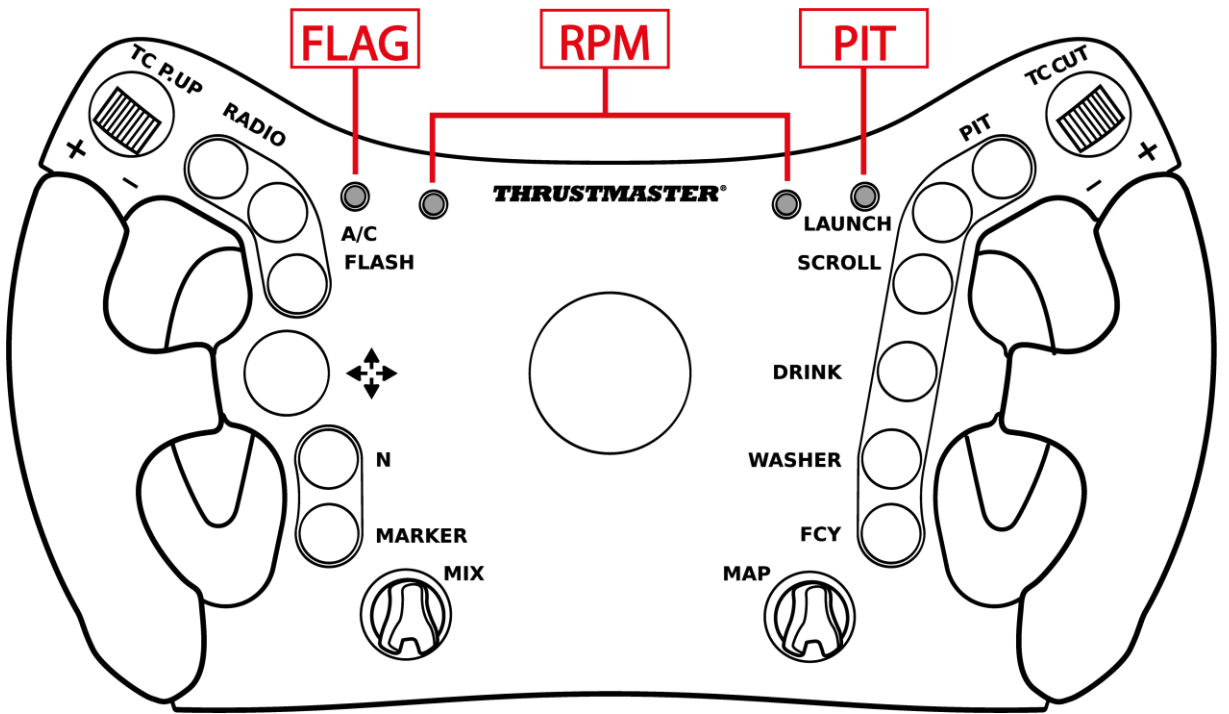

تعمل مصابيح LED على أجهزة الكمبيوتر الشخصية وأجهزة PS5™/PS4™. على Xbox One و Xbox Series، لا تعمل مصابيح LED بسبب قيود بروتوكول الجهاز.



كيفية الدخول/الخروج من قائمة LED

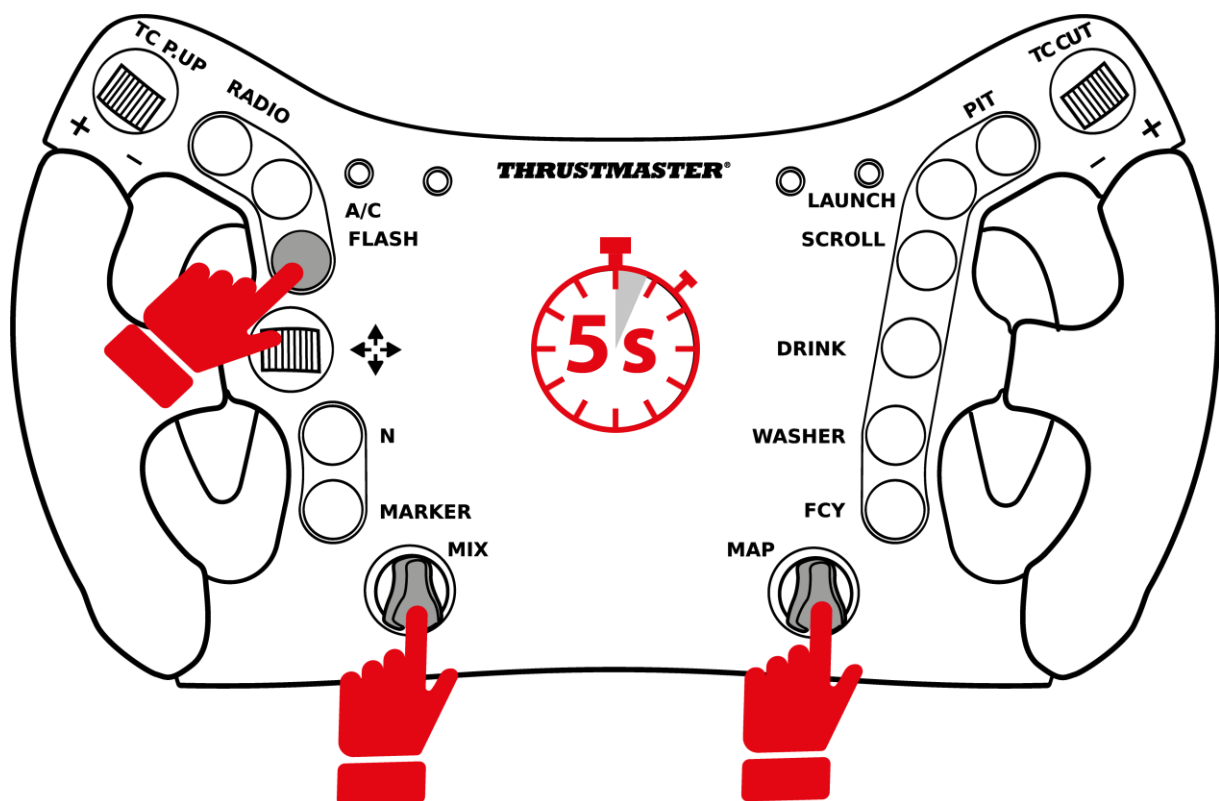

- للدخول إلى قائمة LED، اضغط على الزر **FLASH** وكلا المحولين الدوارين في الوقت نفسه لمدة 5 ثوانٍ، ثم أفلتتهم.

- للخروج من قائمة LED، اضغط على الزر **FLASH** وكلا المحولين الدوارين في الوقت نفسه، ثم أفلتتهم.



FLAG

RPM

PIT



ادخل إلى قائمة LED: يضيء مصباحي FLAG وPIT وأحد مصابيح LED لسرعة المحرك (باللون الأحمر على اليسار، أو الأزرق على اليمين).



الخروج من قائمة LED: يتم إيقاف تشغيل جميع مصابيح LED الأربعة.



كيفية ضبط شدة إضاءة مصابيح LED

- ادخل إلى قائمة LED بالضغط على الزر **FLASH** وكلا المحولين الدوارين في الوقت نفسه لمدة 5 ثوانٍ، ثم أفلتتهم.
- أدر المحول الأيسر **MIX** إلى اليسار لتقليل شدة الإضاءة، أو إلى اليمين لرفع شدة الإضاءة.



- اخرج من قائمة LED بالضغط على الزر **FLASH** وكلا المحولين الدوارين في نفس الوقت، ثم أفلتتهم.

كيفية تغيير وضع مصابيح LED: GT3 أو Formula

- ادخل إلى قائمة LED بالضغط على الزر **FLASH** وكلا المحولين الدوارين في الوقت نفسه لمدة **5 ثوانٍ**، ثم أفلتهم.
- أدر المحول الأيمن (**MAP**) إلى اليسار لتحديد وضع GT3 (ضوء LED أحمر)، أو إلى اليمين لتحديد وضع Formula (ضوء LED أزرق).



وضع GT3 (الوضع الافتراضي)



وضع FORMULA

- اخرج من قائمة LED بالضغط على الزر **FLASH** وكلا المحولين الدوارين في نفس الوقت، ثم أفلتهم.

7. تخصيص ناقلي الحركة

يمكن تعديل ناقلي الحركة Ferrari 488 GT3 Wheel Add-On من حيث التباعد والاتساع.

يتمثل التباعد في ضبط عرض ناقل الحركة، ما يعدل المسافة بين المقبض وناقل الحركة.

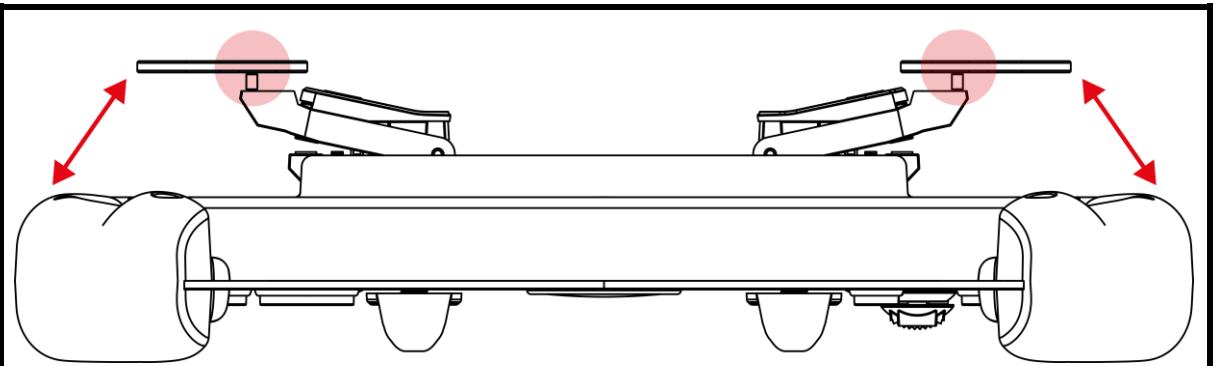

المسافة بين المقبض وناقل الحركة - بصورة افتراضية

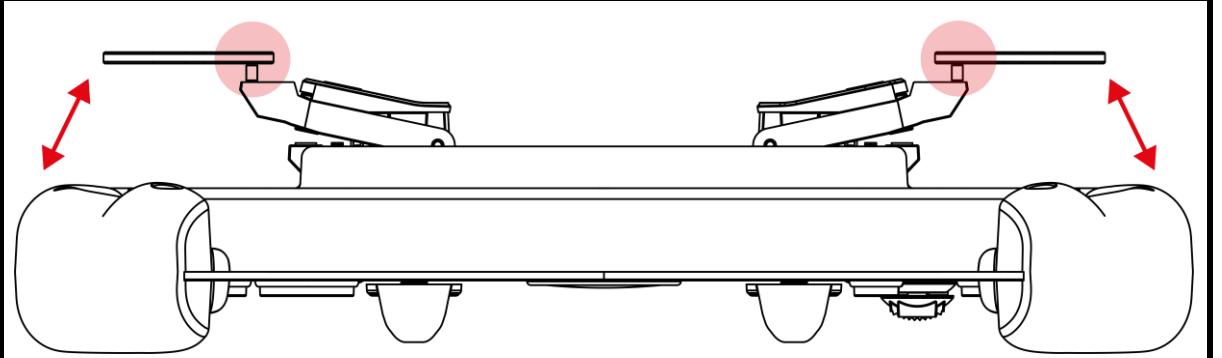

مسافة أقصر من المقبض إلى ناقل الحركة

يؤدي ضبط الاتساع باستخدام المبادعات إلى تعديل مسافة تنشيط ناقل الحركة.

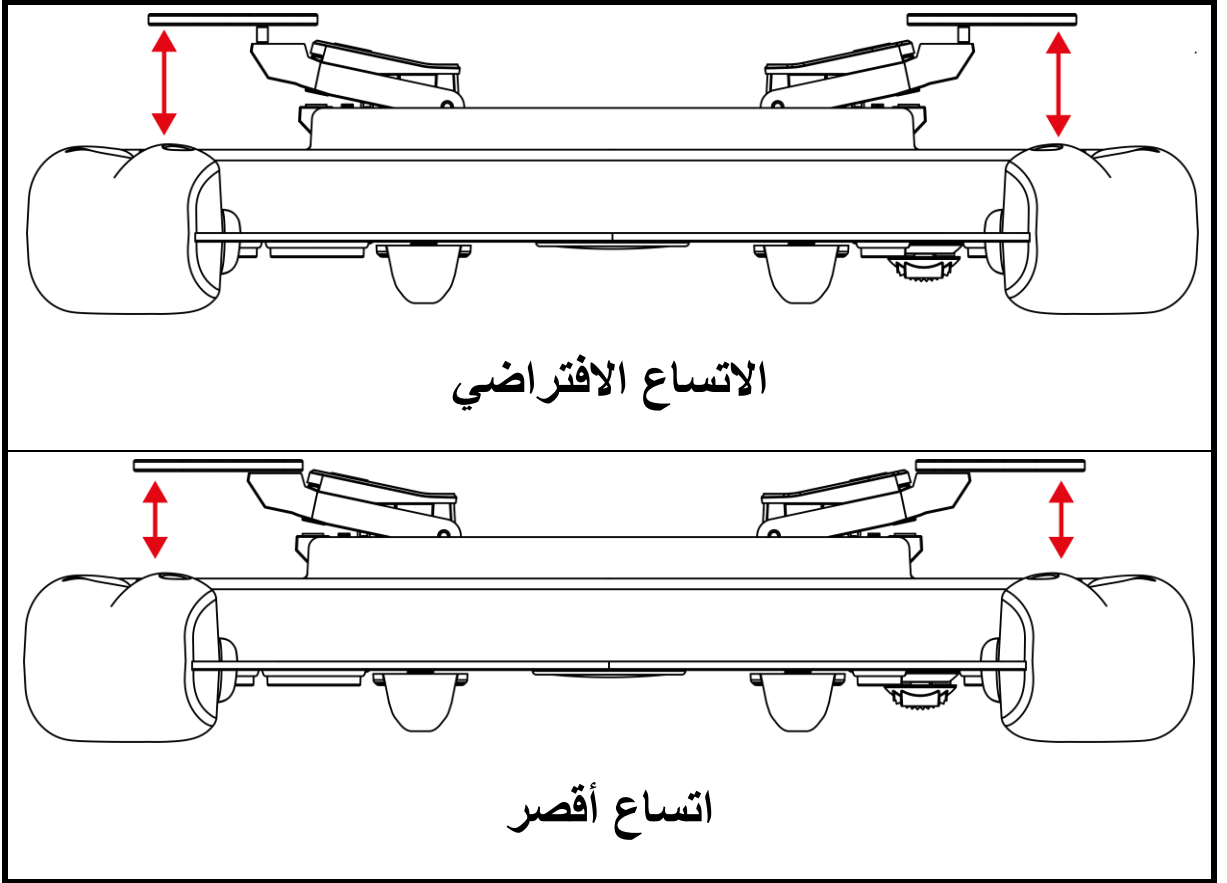

يمكن أيضاً ضبط الحساسية المغناطيسية ومستوى الصوت الناتج عن ناقلي الحركة باستخدام مجموعة الوسادات المرفقة.

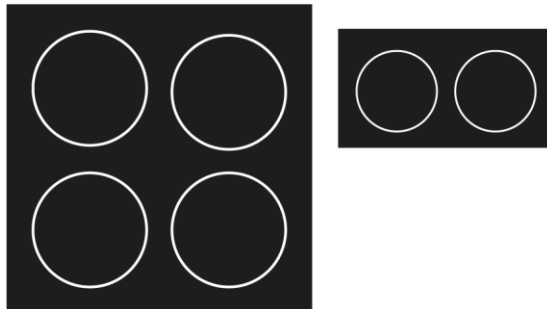



كيفية ضبط مسافة ناقل الحركة

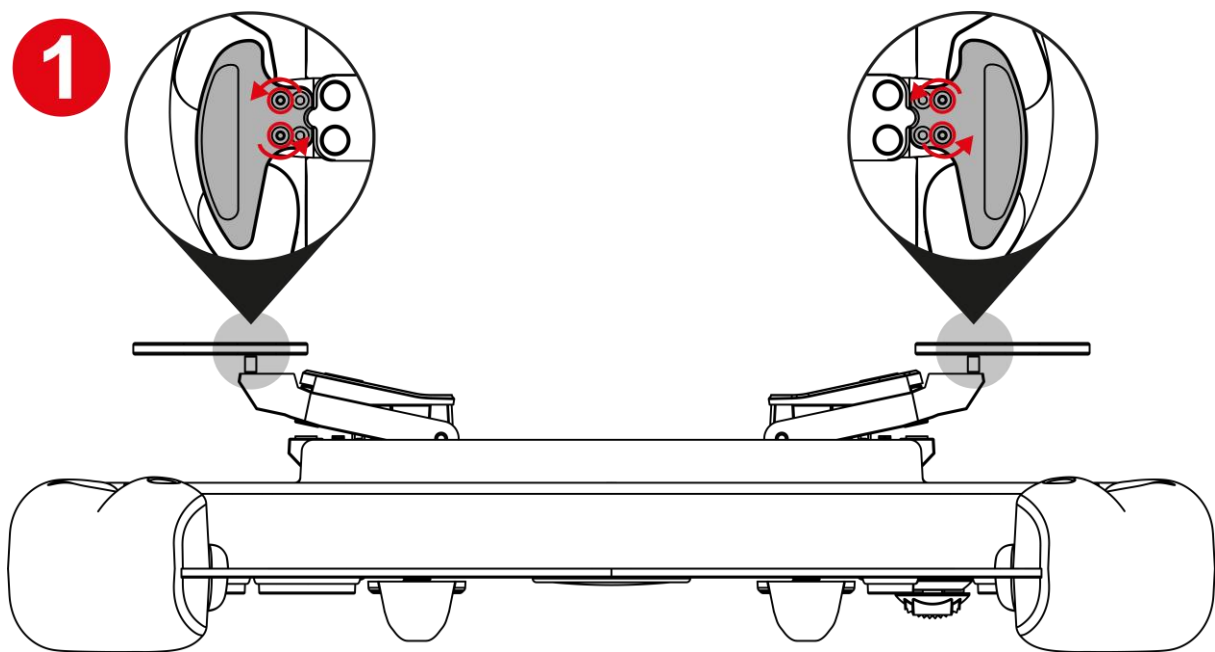

1 فك مسامير ناقلي الحركة الأربعة باستخدام المفك السداسي المرفق.

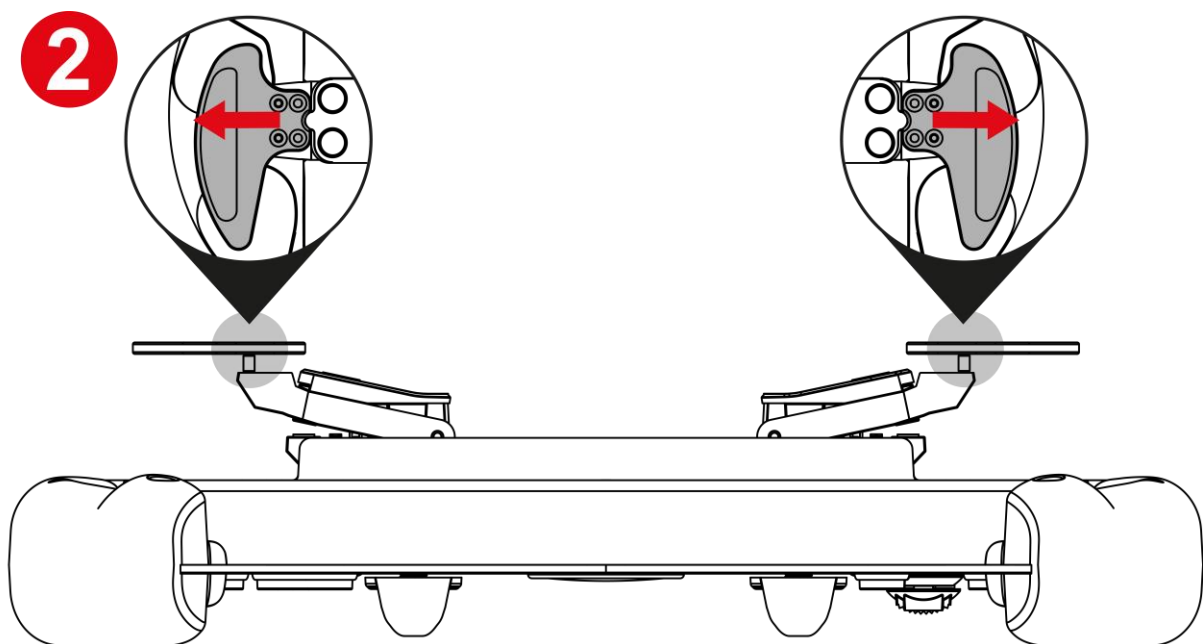

2 قم بتحريك ناقلي الحركة للخارج ليتناسبا مع الفتحتين.

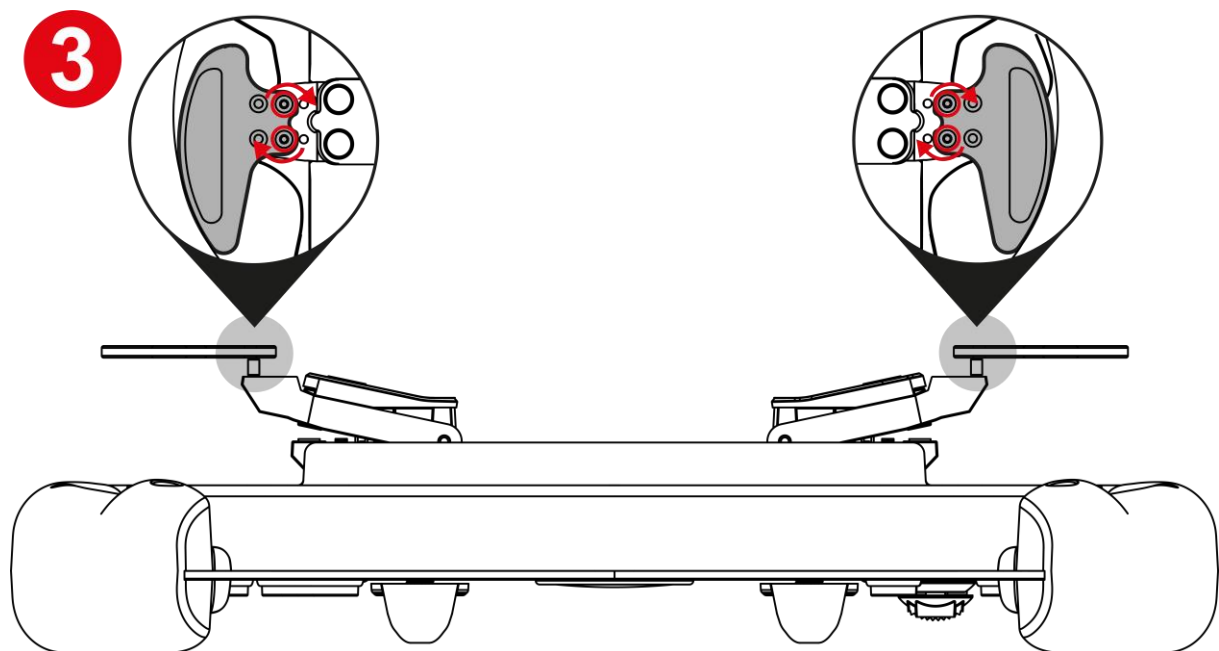

3 اربط مسامير ناقلي الحركة الأربعة باستخدام المفك السداسي المرفق.



كيفية ضبط اتساع ناقل الحركة

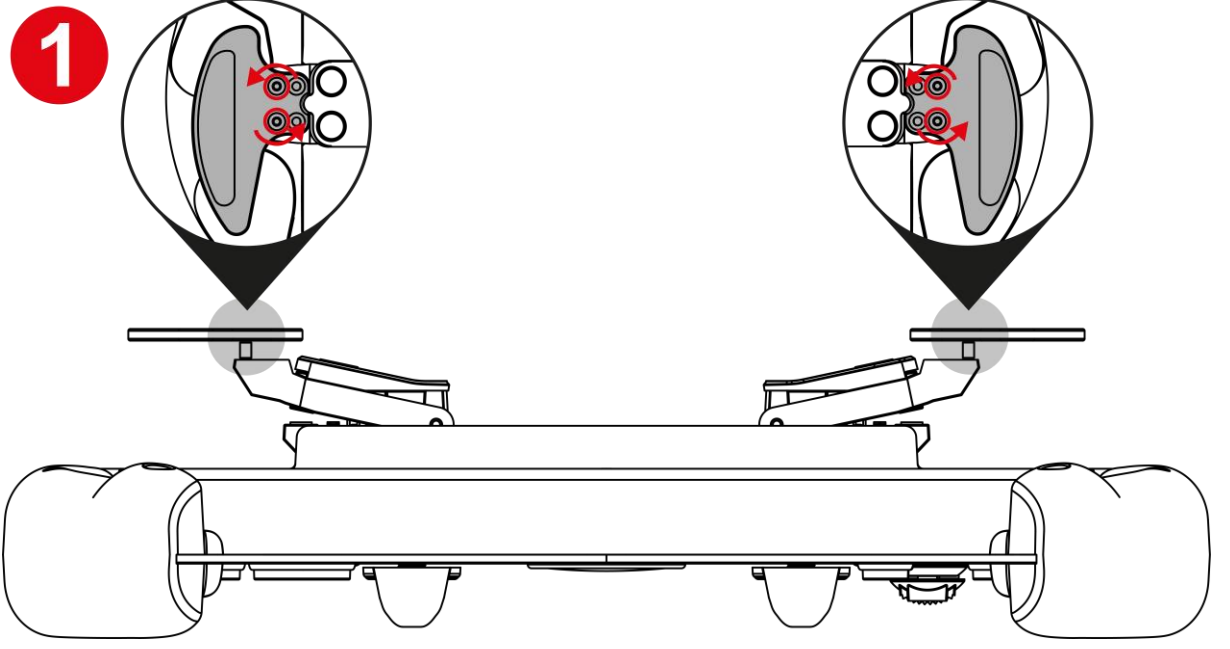

1 فك مسامير ناقلي الحركة الأربعة باستخدام المفك السداسي المرفق.

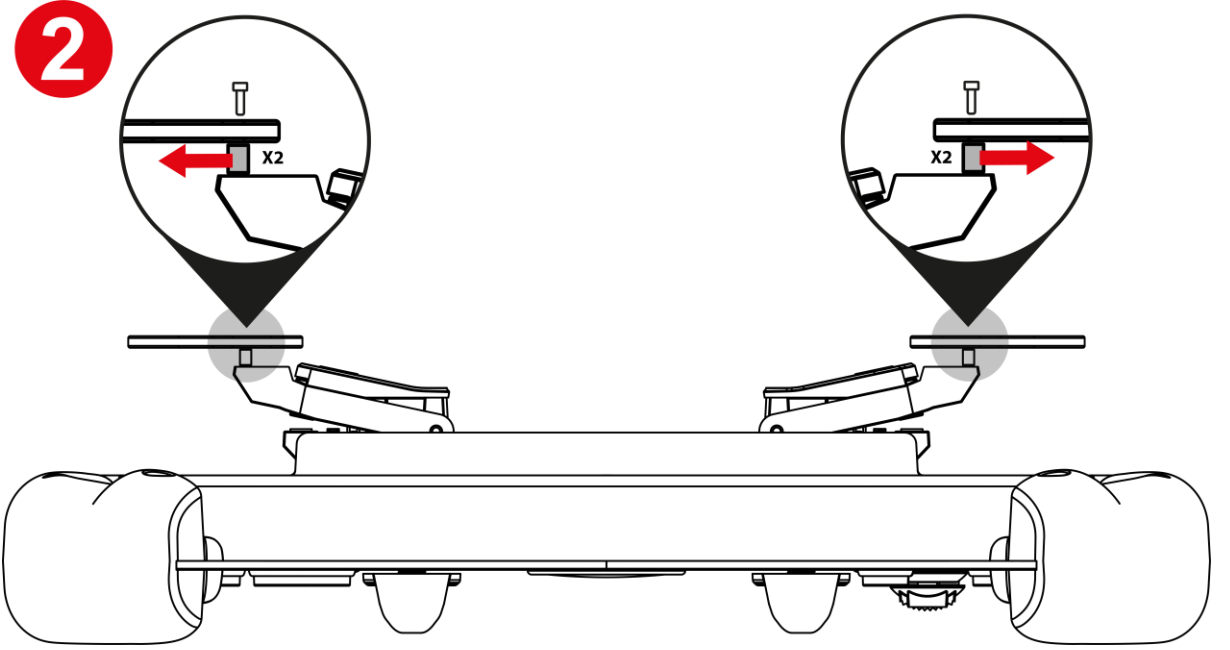

2 أزل المبعادات.



3

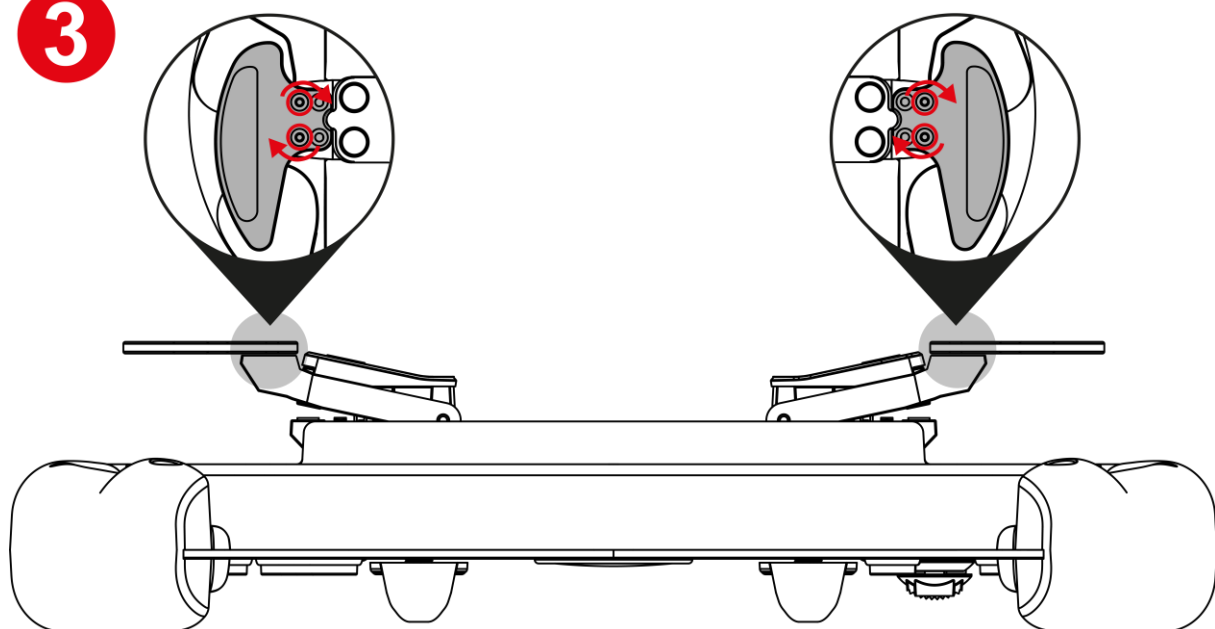

3 اربط مسامير ناقلي الحركة الأربعة باستخدام المفك السداسي المرفق.

كيفية ضبط الحساسية المغناطيسية ومستوى الصوت لناقلي الحركة

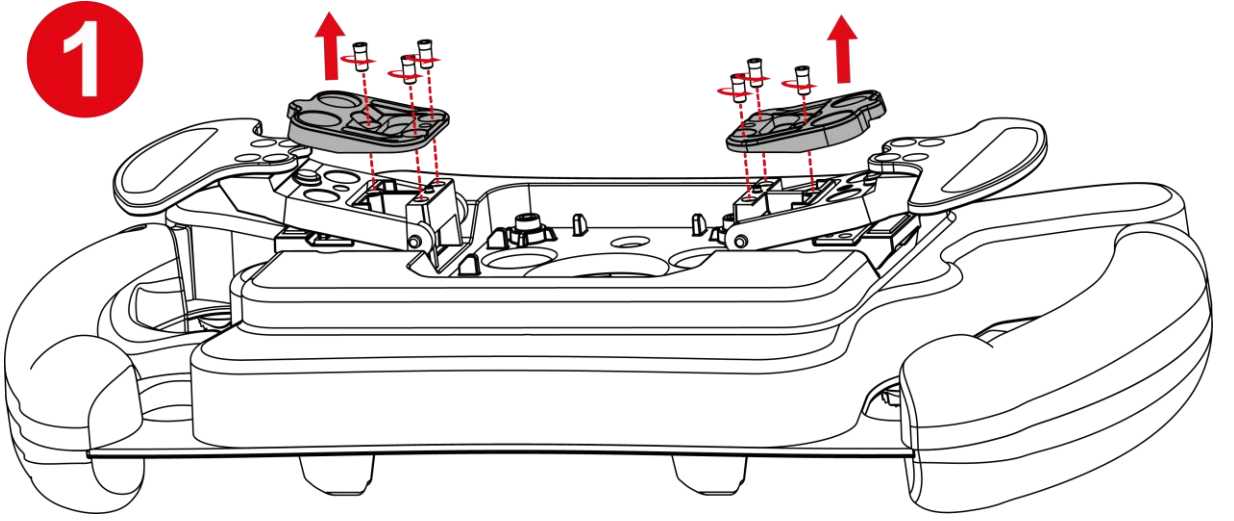

1 أزل السدادتين المغناطيسين بفك مسامير الإيقاف الستة باستخدام المفك السداسي المرفق.

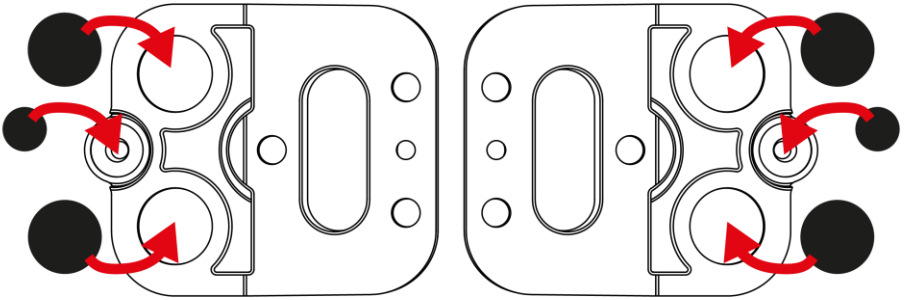
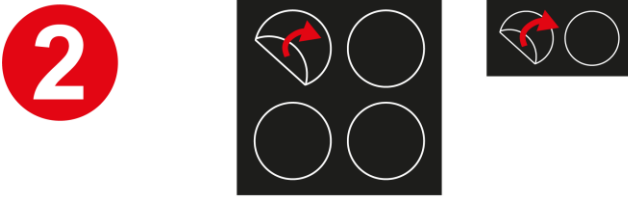

2 انزع الوسائد المرفقة وثبتها في الأماكن المناسبة أسفل السدادتين المغناطيسيتين.



راجع جدول تخفيف صوت ناقل الحركة والحساسية المغناطيسية للتعرف على التكوينات المحتملة وتأثيراتها.



3

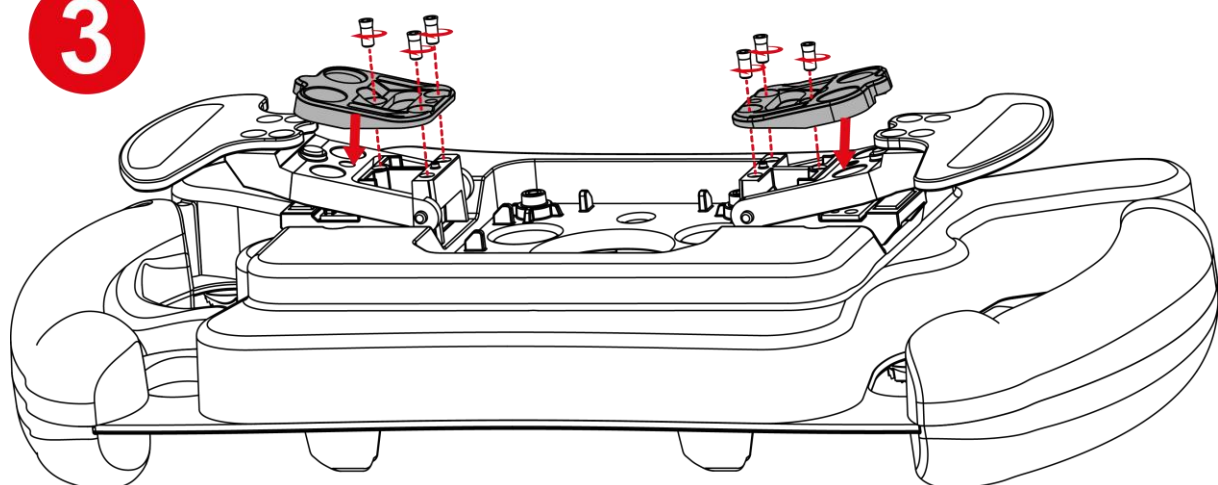

3 أعد تركيب السدادات المغناطيسية وأحكم ربط مسامير الإيقاف الستة باستخدام المفك السداسي المرفق.

جدول تخفيف صوت ناقل الحركة والحساسية المغناطيسية

			(بصورة) افتراضية)
			الحساسية المغناطيسية
			الصوت



8. الأسئلة الشائعة والدعم الفني

هل لديك أسئلة بخصوص Ferrari 488 GT3 Wheel Add-On، أو هل تواجه مشاكل فنية؟ إذا كان الأمر كذلك، ففضل بزيارة الموقع الإلكتروني للدعم الفني لشركة Thrustmaster:

<https://support.thrustmaster.com/product/ferrarif488.gt3addon>

في هذه الصفحة، يمكنك أيضًا تحديث البرنامج الثابت للعجلة.



THRUSTMASTER®

FERRARI 488 GT3 WHEEL ADD-ON

PC (Windows 10/11)

PS4™ / PS5™

Xbox Series / Xbox One

Användarmanual



Läs noggrant igenom instruktionerna i denna manual **innan** du installerar produkten, **innan** produkten används och **innan** underhåll utförs på den. Var noga med att följa säkerhetsinstruktionerna. Att inte följa instruktionerna kan leda till olyckor och/eller skada. Behåll denna manual så att du kan läsa instruktionerna även i framtiden.

INNEHÅLLSFÖRTECKNING

1.	INNEHÅLL I FÖRPACKNINGEN	5
2.	FUNKTIONER	6
3.	INFORMATION RÖRANDE ANVÄNDNINGEN AV RATTEN	8
4.	INSTALLATION AV SNABBURKOPPLINGSHÅLLAREN	13
	<i>Installation av snabburkopplingshållaren för spärrbasar</i>	<i>14</i>
	<i>Installation av snabburkopplingshållaren för skruvbasar</i>	<i>17</i>
5.	MAPPNING	21
	<i>Mappning på PC</i>	<i>21</i>
	<i>Mappning på PS4™/PS5™</i>	<i>22</i>
	<i>Mappning på Xbox Series/Xbox One.....</i>	<i>23</i>
6.	LED-LAMPORNA	24
	<i>Öppna/stänga LED-menyn</i>	<i>25</i>
	<i>Justera LED-lampornas intensitet.....</i>	<i>27</i>

	<i>Ändra LED-läge: GT3 eller Formula</i>	28
7.	ANPASSA VÄXELPADDLARNAN	29
	<i>Justera växelpaddlarnas mellanrum</i>	31
	<i>Justera växelpaddlarnas räckvidd</i>	33
	<i>Justera växelpaddlarnas magnetiska känslighet och ljudnivå.....</i>	35
8.	VANLIGA FRÅGOR OCH TEKNISK SUPPORT	37



FERRARI 488 GT3 WHEEL ADD-ON

Var en del av legenden inom GT-racing med Ferrari 488 GT3 Wheel Add-On, en ratt som är designad för att prestera och kompatibel med alla rattbasar från Thrustmaster.

Denna manual hjälper dig att installera och använda din Ferrari 488 GT3 Wheel Add-On med så bra förutsättningar som möjligt. Läs noggrant igenom instruktionerna och varningarna innan du börjar köra: de hjälper dig att få ut så mycket som möjligt av din produkt.



1. Innehåll i förpackningen

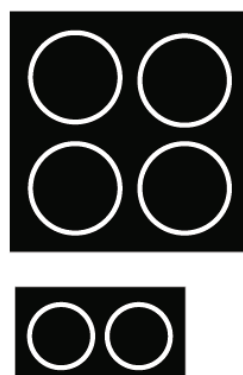
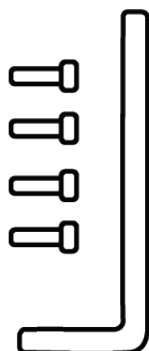
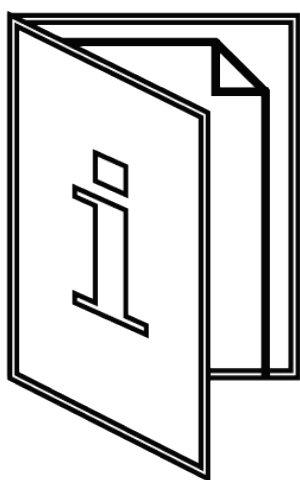
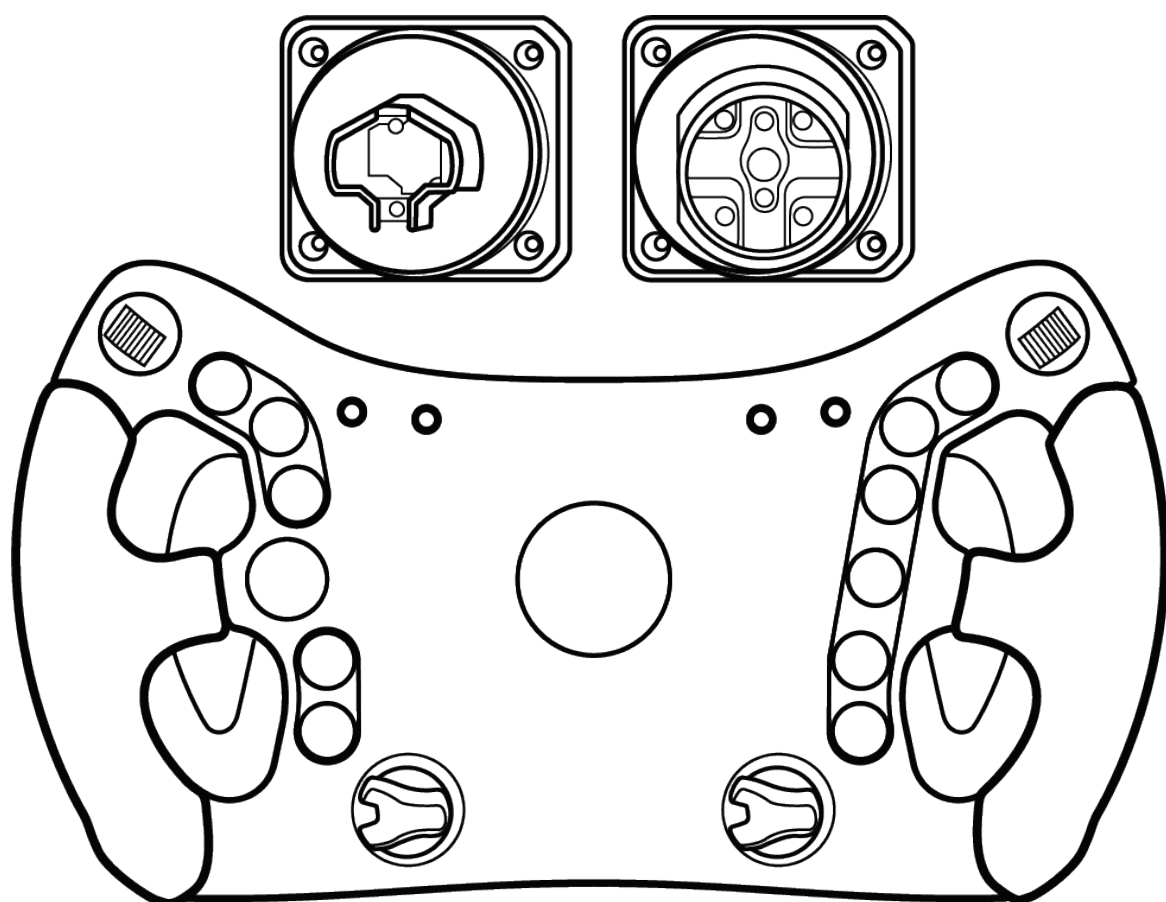



2. Funktioner

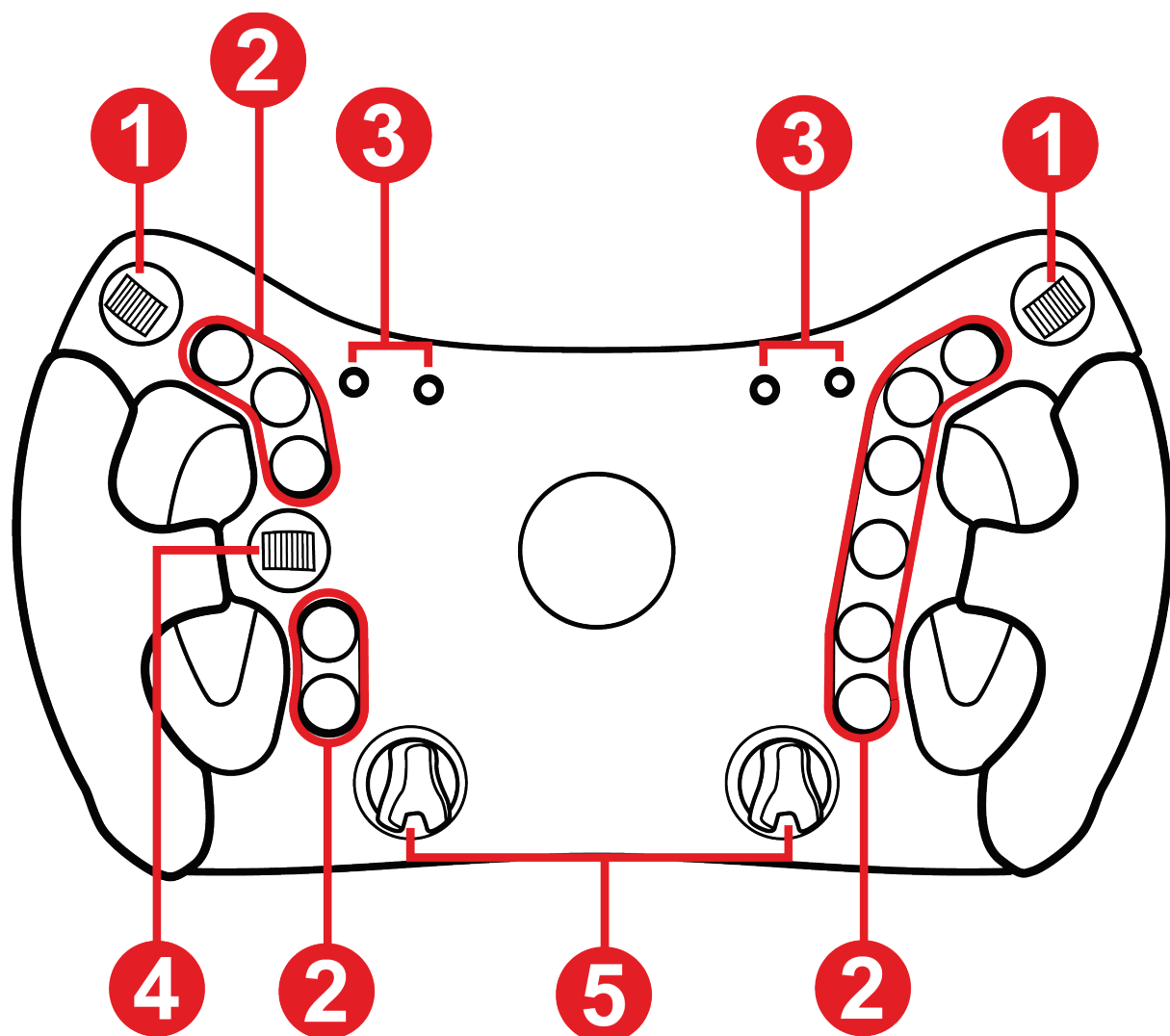

❶ Tumencoders

❷ 11 åtgärdsknappar

❸ Varvtalslampor och raceinformation (flaggor, depåer)

❹ Styrknapp

❺ Vridbara encoders

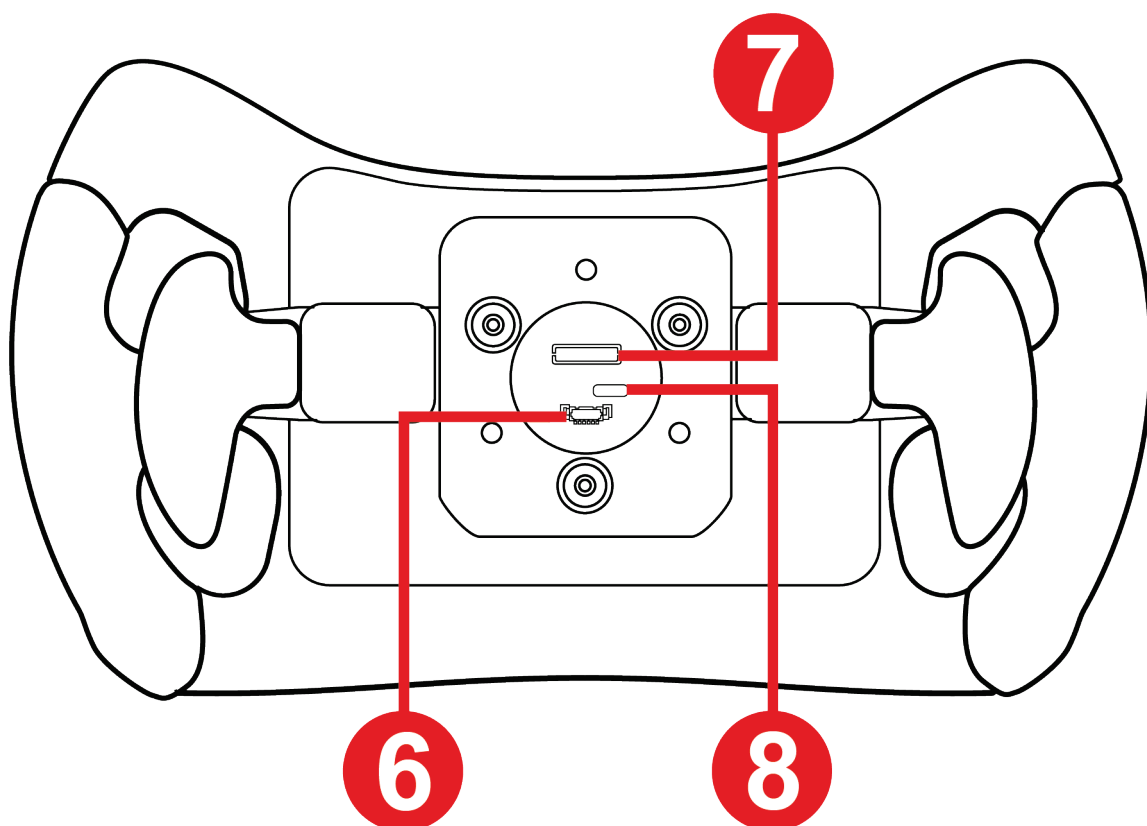

⑥ Anslutningsport för snabburkopplingshållaren för skruvbasar

⑦ Anslutningsport för snabburkopplingshållaren för spärrbasar

⑧ USB-C-port (om en firmwareuppdatering behövs – kabel ingår ej)

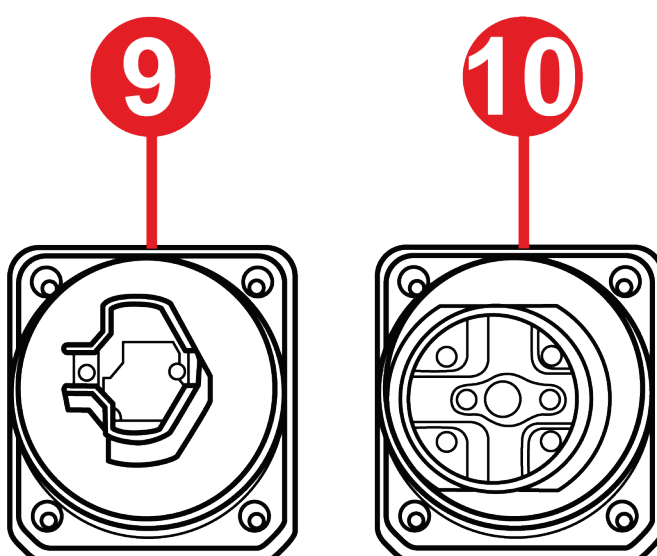

⑨ Snabburkopplingshållare för spärrbasar

⑩ Snabburkopplingshållare för skruvbasar



3. Information rörande användningen av ratten



Dokumentation

Läs noggrant igenom denna dokumentation igen innan du använder produkten och spara den för framtida bruk.



Elektriska stötar

- Förvara produkten på ett torrt ställe och utsätt den inte för damm eller solljus.
- Vrid och dra inte i kontakter och kablar.
- Sätt i kontakter på rätt sätt.
- Spill inte vätskor på produkten eller dess kontakter.
- Kortslut inte produkten.
- Montera aldrig isär produkten (förutom om så anges i manualen), kasta inte in den i eld och utsätt den inte för höga temperaturer.
- Öppna inte enheten: det finns inga delar däri som får repareras av användaren. Eventuella reparationer måste utföras av tillverkaren, en specificerad byrå eller en behörig tekniker.



Säkra spelområdet

- Ha inga föremål i spelområdet som kan störa användaren, leda till olämpliga rörelser, eller göra att en annan person kommer och avbryter (till exempel kaffekoppar, telefoner, nycklar).
- Täck inte över strömkablarna med en matta, filt, ett täcke eller något annat och ha inga kablar där personer går.



Skador på grund av Force Feedback och upprepade rörelser

Att använda en racingratt med Force Feedback kan leda till muskel- eller ledvärk. För att undvika problem:

- Värm upp innan du börjar och undvik att träna för länge.
- Ta 10 till 15 minuters paus efter varje timme av träning.
- Om du känner smärta eller trötthet i händerna, handlederna, armarna, fötterna eller benen ska du trycka på knappen för att stänga av Force Feedbacken, stänga av basen och vila i några timmar innan du tränar igen.
- Om ovannämnda symtom eller smärtor består när du fortsätter träna ska du sluta träna och kontakta din läkare.
- Ställ inte in Force Feedbacken på en nivå som är för hög för din kunskap eller ditt hälsotillstånd.
- Förvara enheten utom räckhåll för personer under 16 år.
- Kontrollera att basen och ratten är ordentligt monterade enligt instruktionerna i manualen.



Risk för oförutsedda, kraftfulla och snabba rotationer: för aldrig in en hand eller arm genom rattringens öppningar eller i rattens rotationsbana.

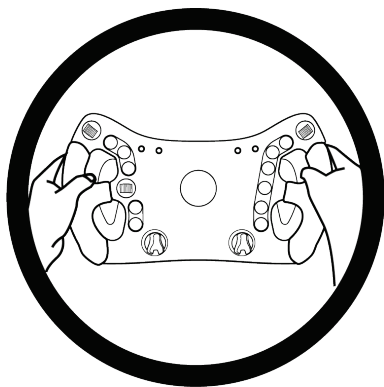

Medan du använder produkten ska du alltid ha båda händerna i rätt position på ratten och aldrig helt släppa taget om den.



Produkten får endast hanteras av personer som är **16 år eller äldre**.



4. Installation av snabburkopplingshållaren

Ferrari 488 GT3 Wheel Add-On kommer med två snabburkopplingshållare som motsvarar Thrustmasters basformat.

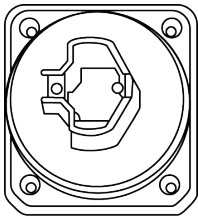
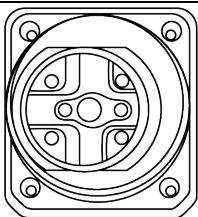
System	Kompatibilitet
 Snabburkopplingshållare för spärrbasar	T818, T818 Ferrari SF1000 Simulator och framtida basar från Thrustmaster.
 Snabburkopplingshållare för skruvbasar	T-GT / T-GT II Servo Base, T300 RS Servo Base, TS PC Racer, TS-XW, TX Racing Wheel Servo Base, TS-XW Servo Base.



Kontrollera varje gång innan du använder **Ferrari 488 GT3 Wheel Add-On** att den sitter ordentligt fast på stödet enligt instruktionerna i basens manual.



Installation av snabburkopplingshållaren för spärrbasar

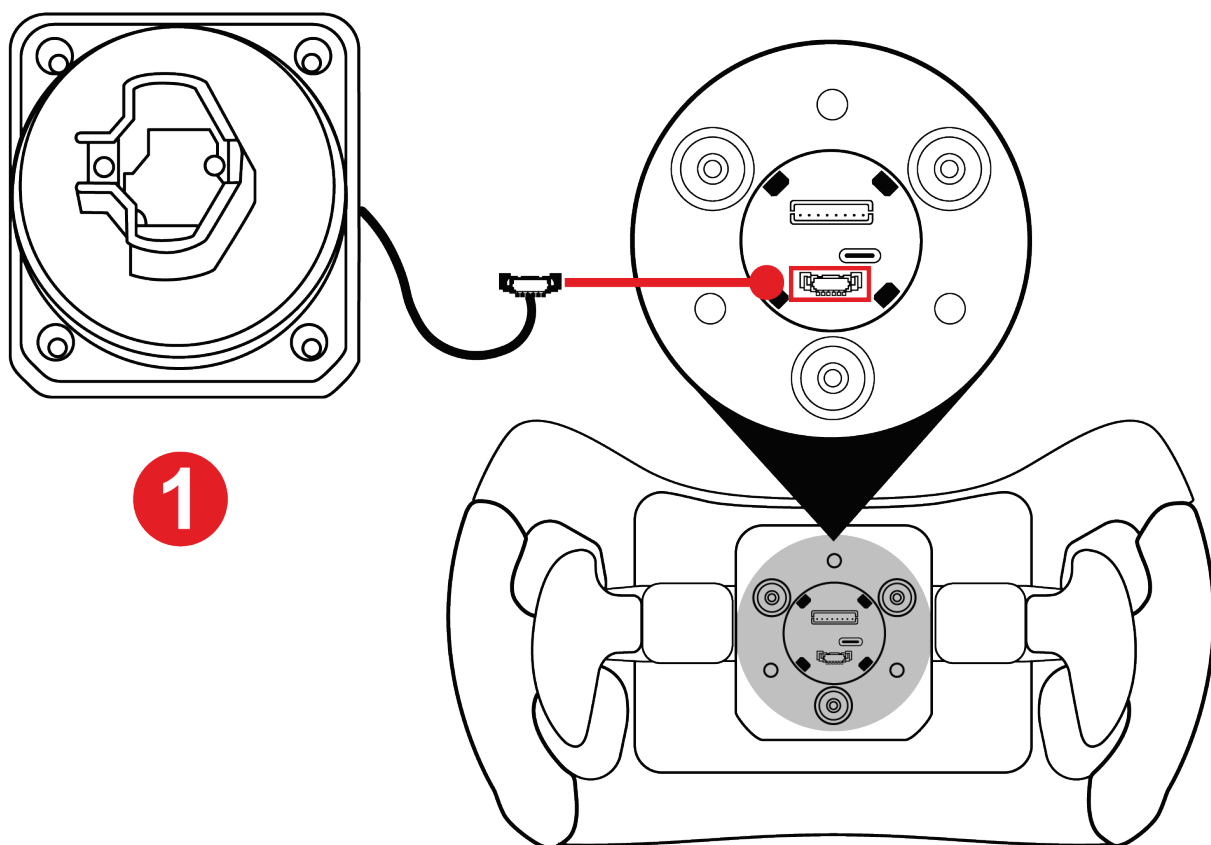

1

1 Anslut snabburkopplingshållarens kontakt till motsvarande port på baksidan av ratten.



Dra in kabeln innan du skruvar i hållaren för att undvika att klämma kabeln.

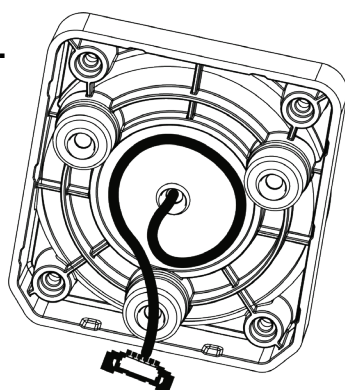

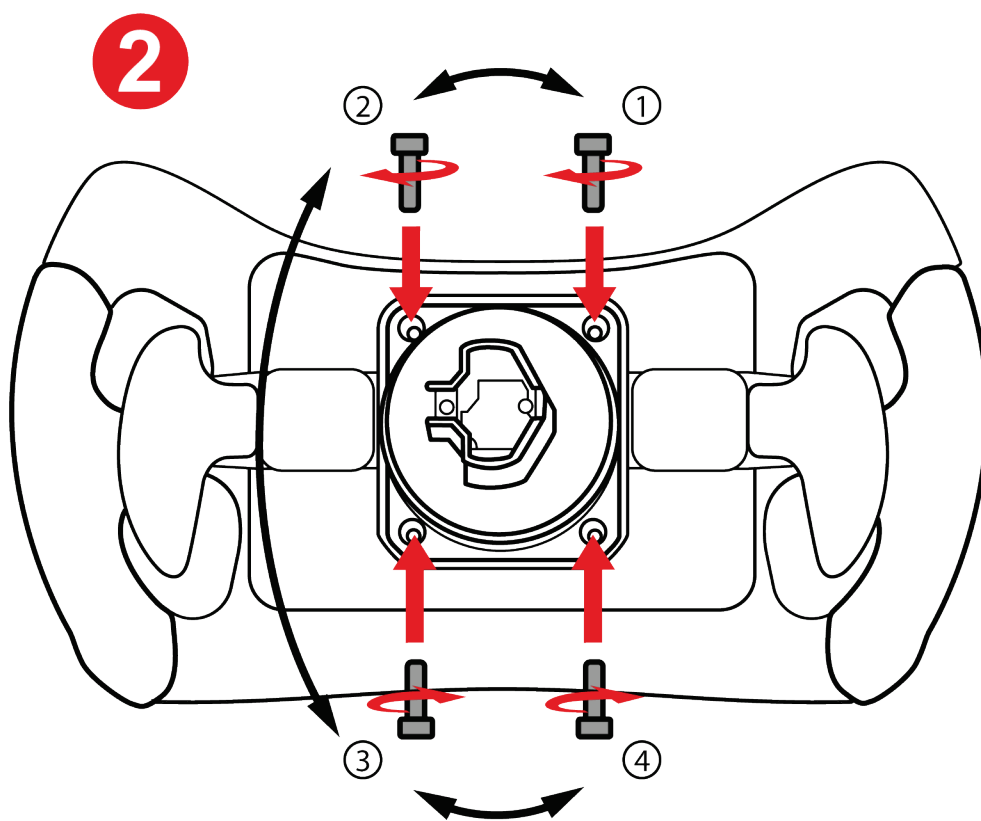

2 Sätt i snabburkopplingshållaren och dra åt med den medföljande Torxnyckeln.



Dra inte åt skruvarna för hårt när du monterar hållaren.

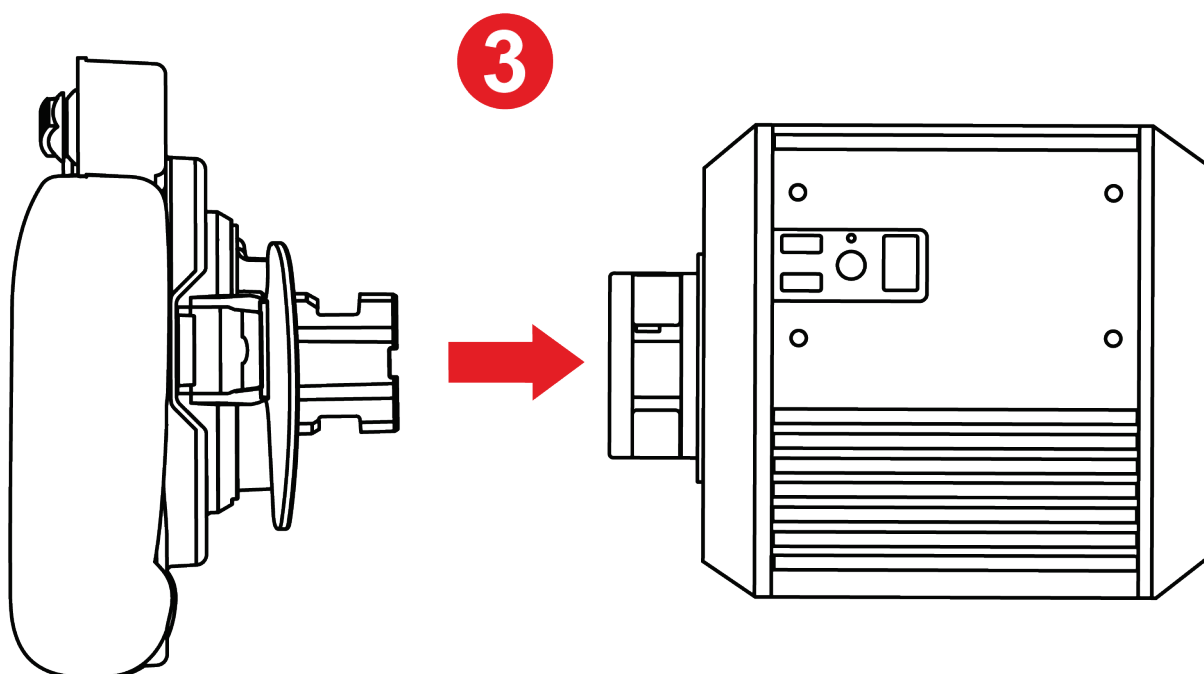

3 Montera ratten på basen.



Följ installationsanvisningarna i basens användarmanual.



Installation av snabburkopplingshållaren för skruvbasar

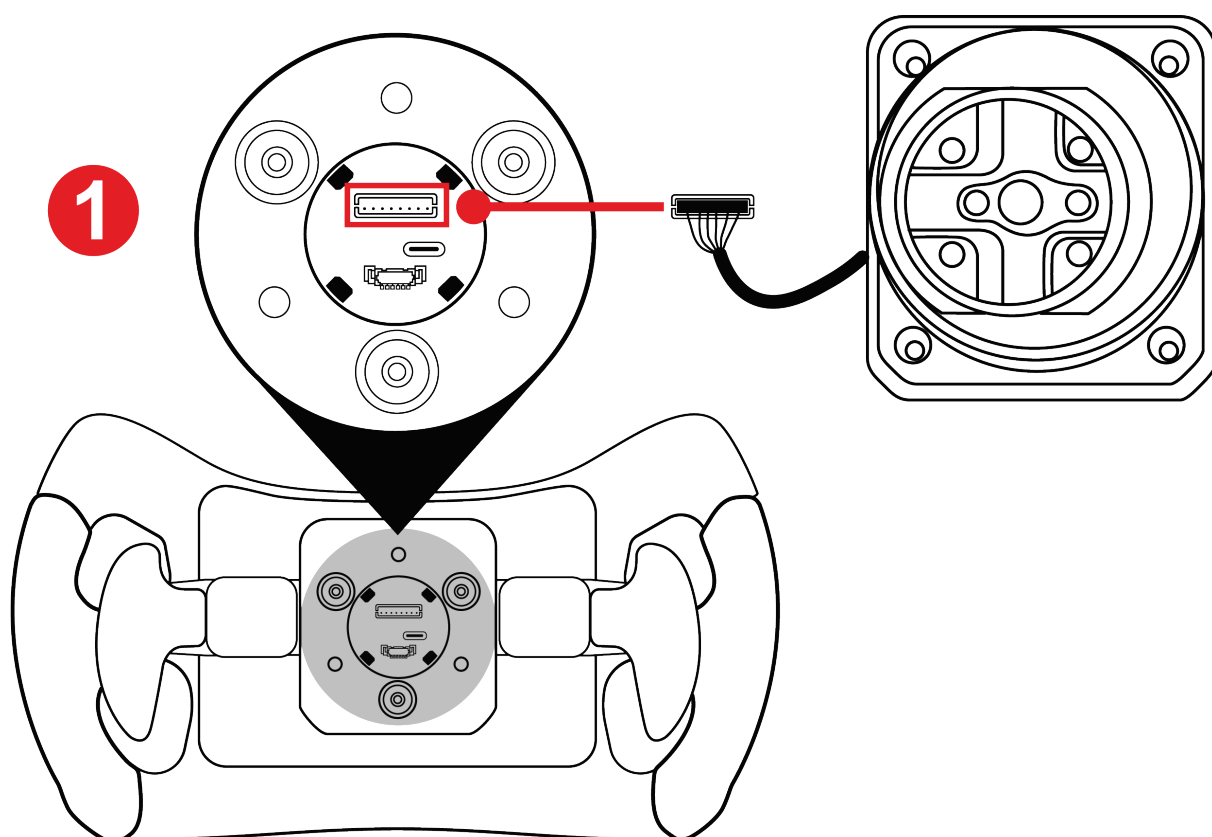

1 Anslut snabburkopplingshållarens kontakt till motsvarande port på baksidan av ratten.



Dra in kabeln innan du skruvar i hållaren för att undvika att klämma kabeln.

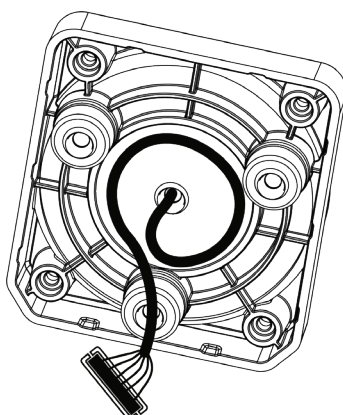

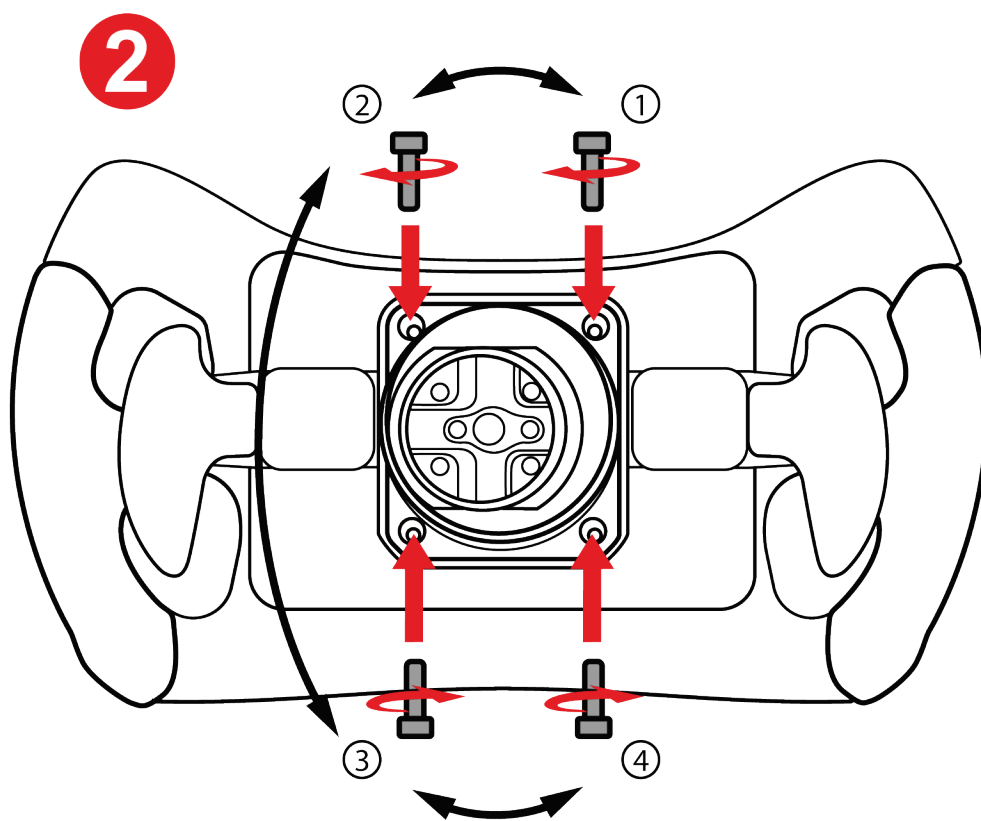

2 Sätt i snabburkopplingshållaren och dra åt med den medföljande Torxnyckeln.



Dra inte åt skruvarna för hårt när du monterar hållaren.

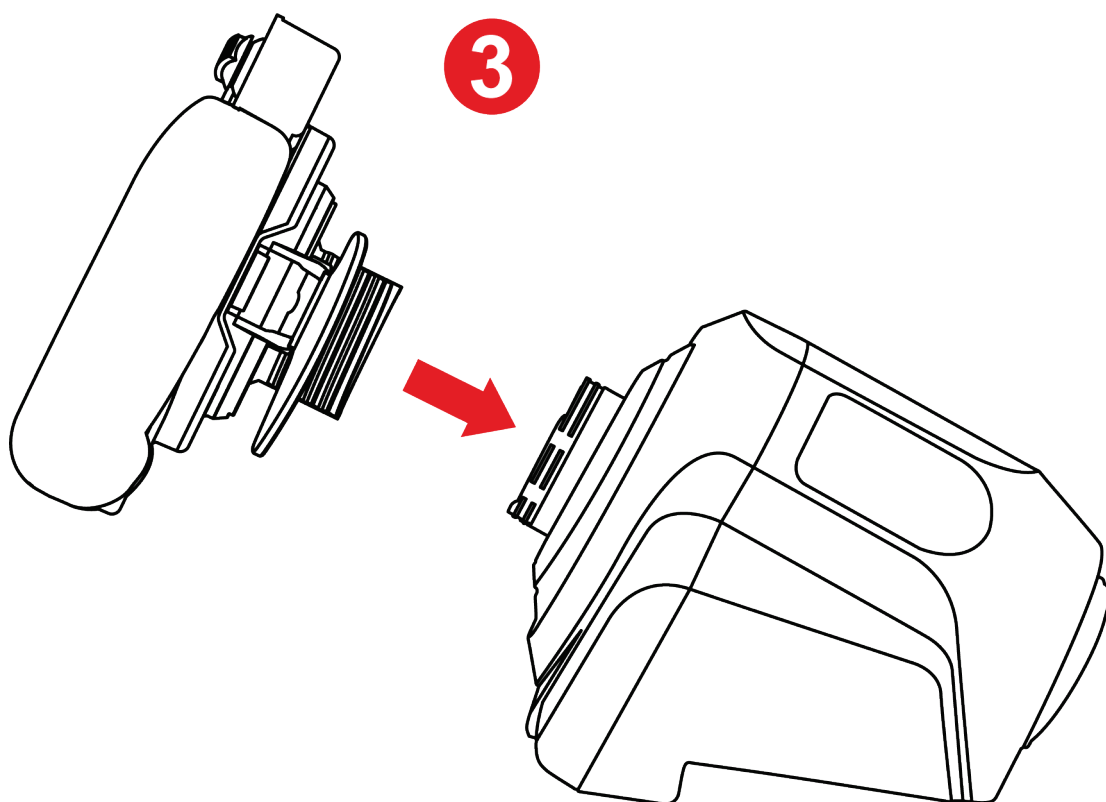

3 Montera ratten på basen.



Följ installationsanvisningarna i basens användarmanual.



Anslut aldrig snabburkopplingsadaptern (medföljer T818-basen och säljs separat) till snabburkopplingshållaren för skruvbasen om du tänker använda den på en T818-bas.

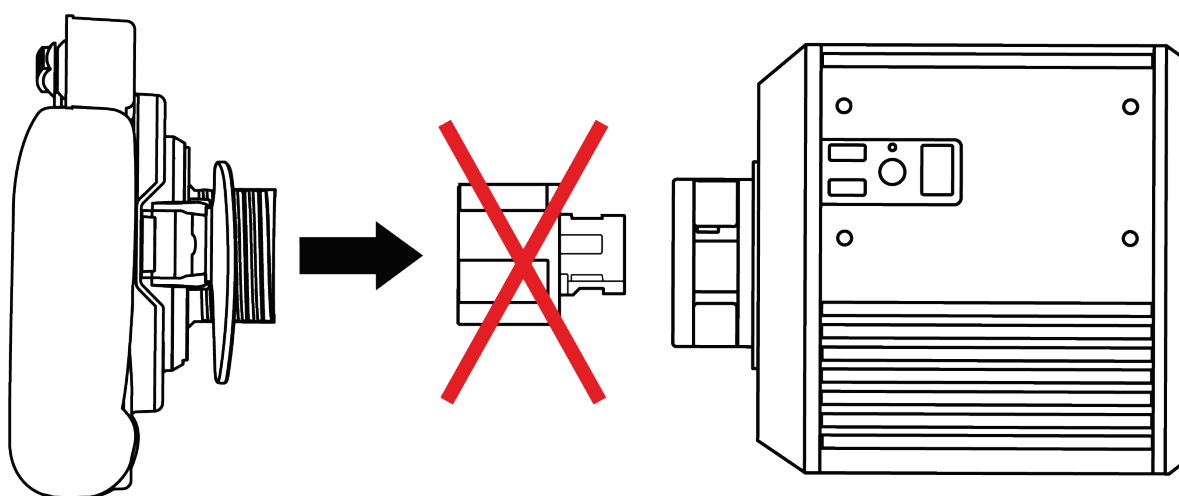
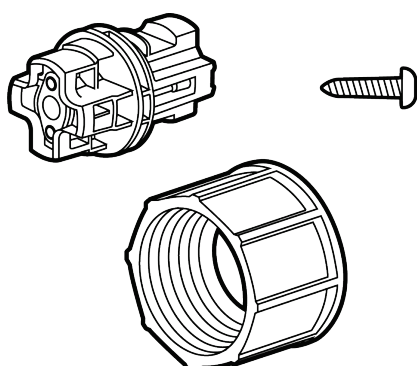

Vid användning på en T818-bas eller en bas utrustad med en kontakt för spärrbasar ska du endast använda **snabburkopplingshållaren för spärrbasar** som medföljer **Ferrari 488 GT3 Wheel Add-On**.



5. Mappning

Mappning på PC

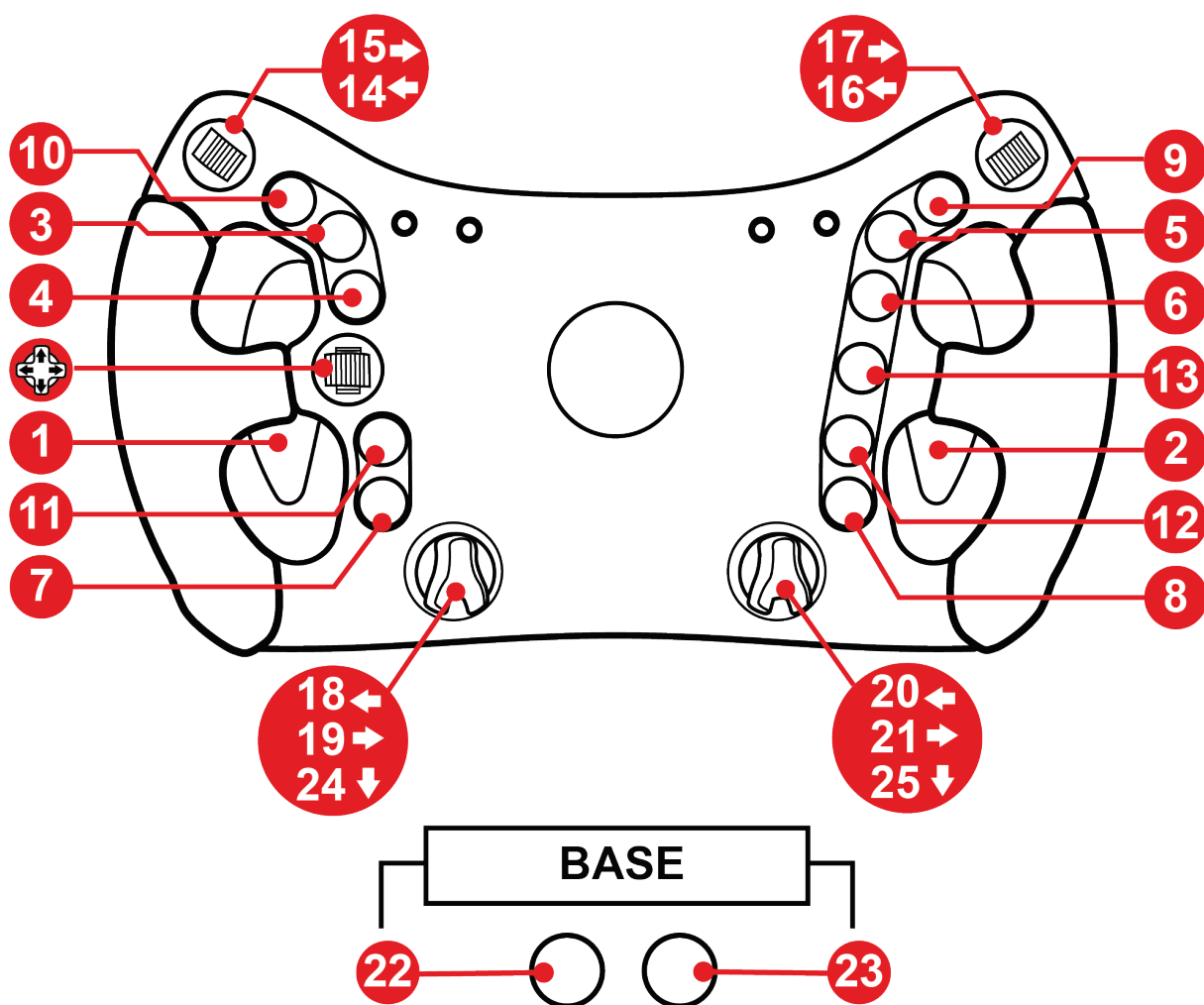



Mappning på PS4™/PS5™

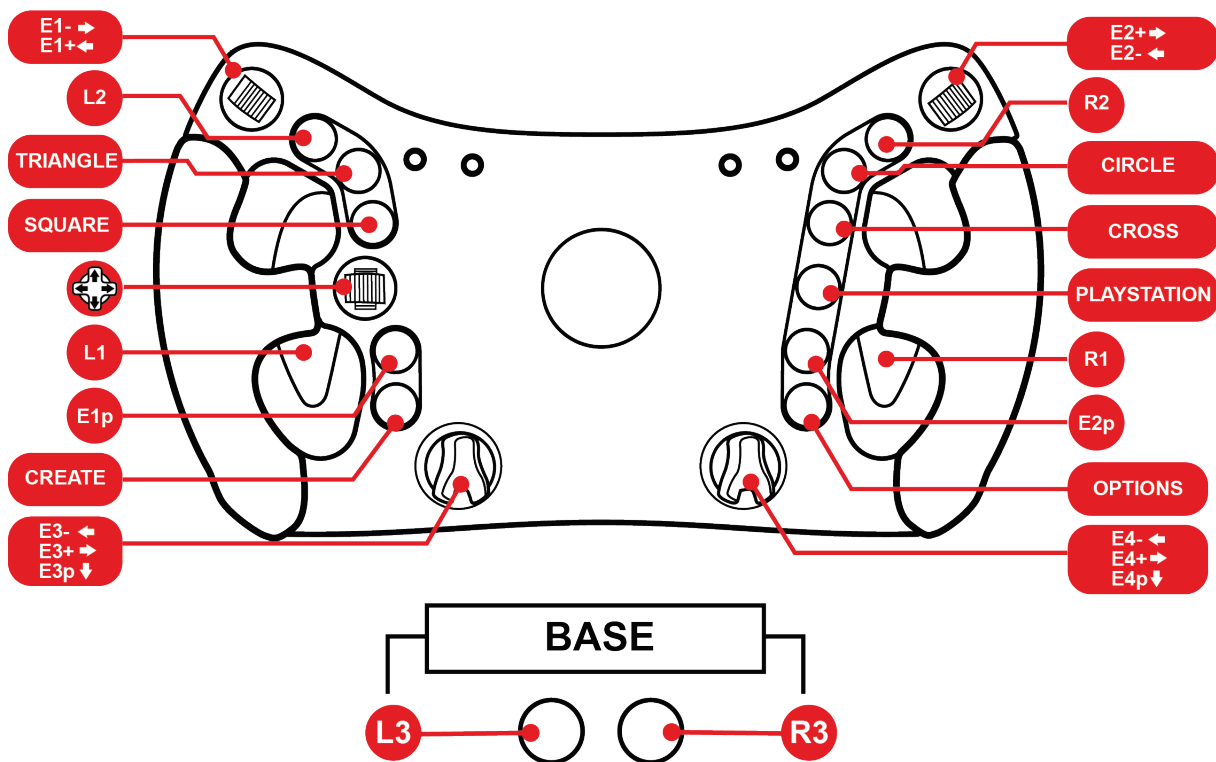



Mappning på Xbox Series/Xbox One

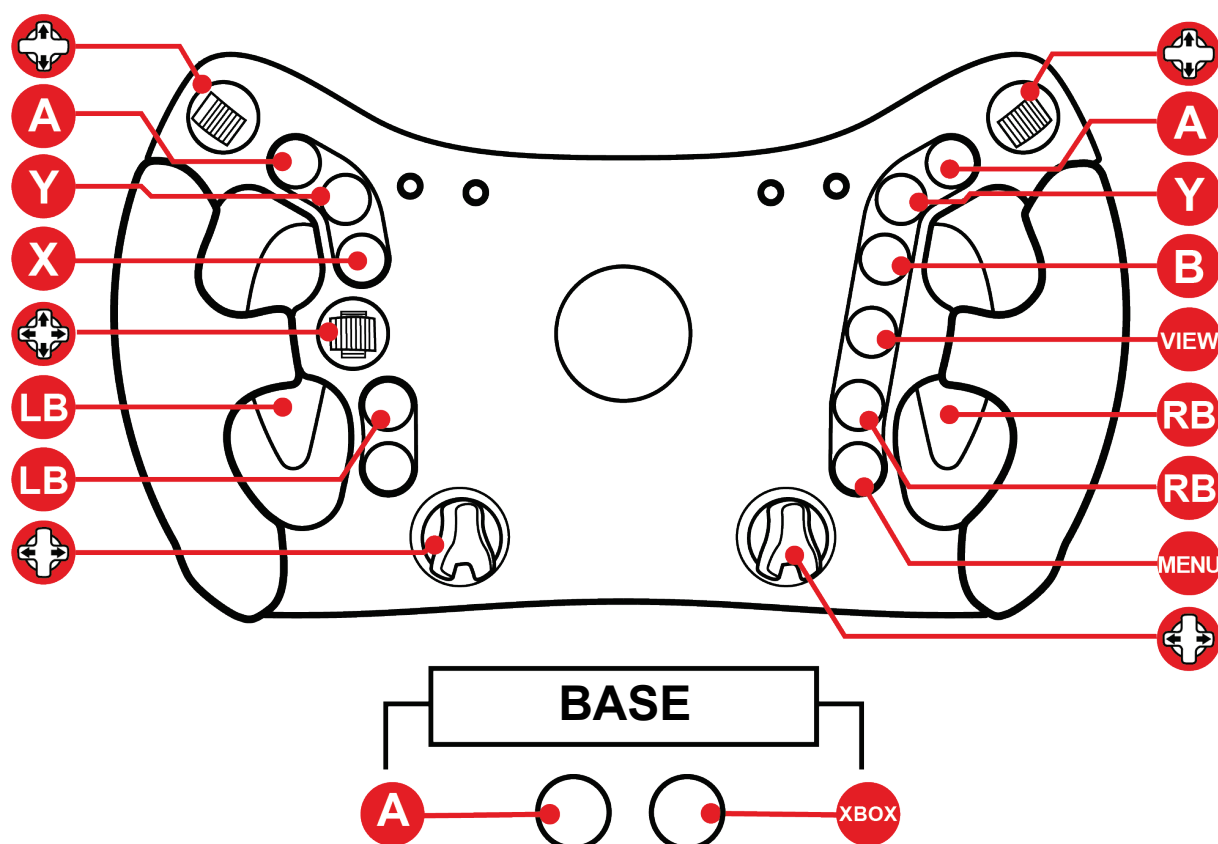

På Xbox Series och Xbox One:

- LED-lamporna på Ferrari 488 GT3 Wheel Add-On fungerar inte på grund av begränsningar i konsolprotokollet.
- Vissa funktioner (encoders, antalet knappar) begränsas av konsolprotokollet.



6. LED-lamporna

Ferrari 488 GT3 Wheel Add-On visar raceinformation via LED-lamporna: flaggor, depåer och varvtal.

Informationen kan anpassas (varvtalslampornas intensitet och färg) beroende på läget (GT3 eller Formula).

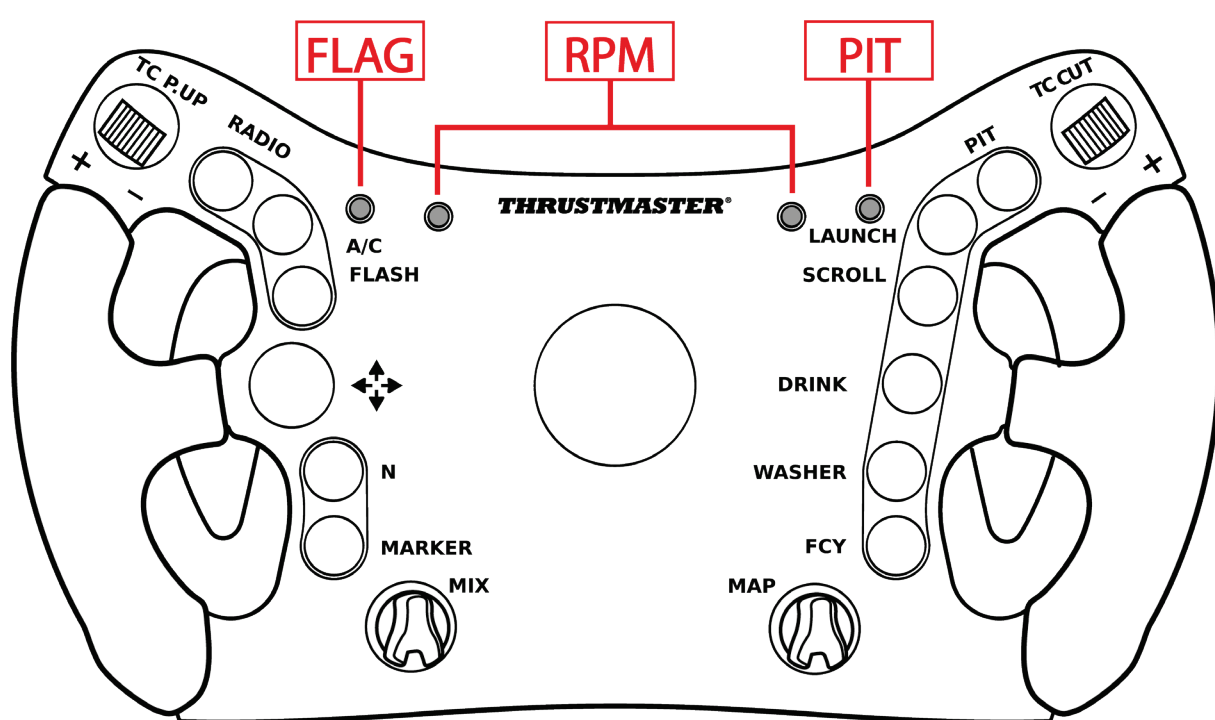

LED-lamporna fungerar på PC och PS4™/PS5™.

På Xbox Series X och Xbox One fungerar inte LED-lamporna på grund av begränsningar i konsolprotokollet.



Öppna/stänga LED-menyn

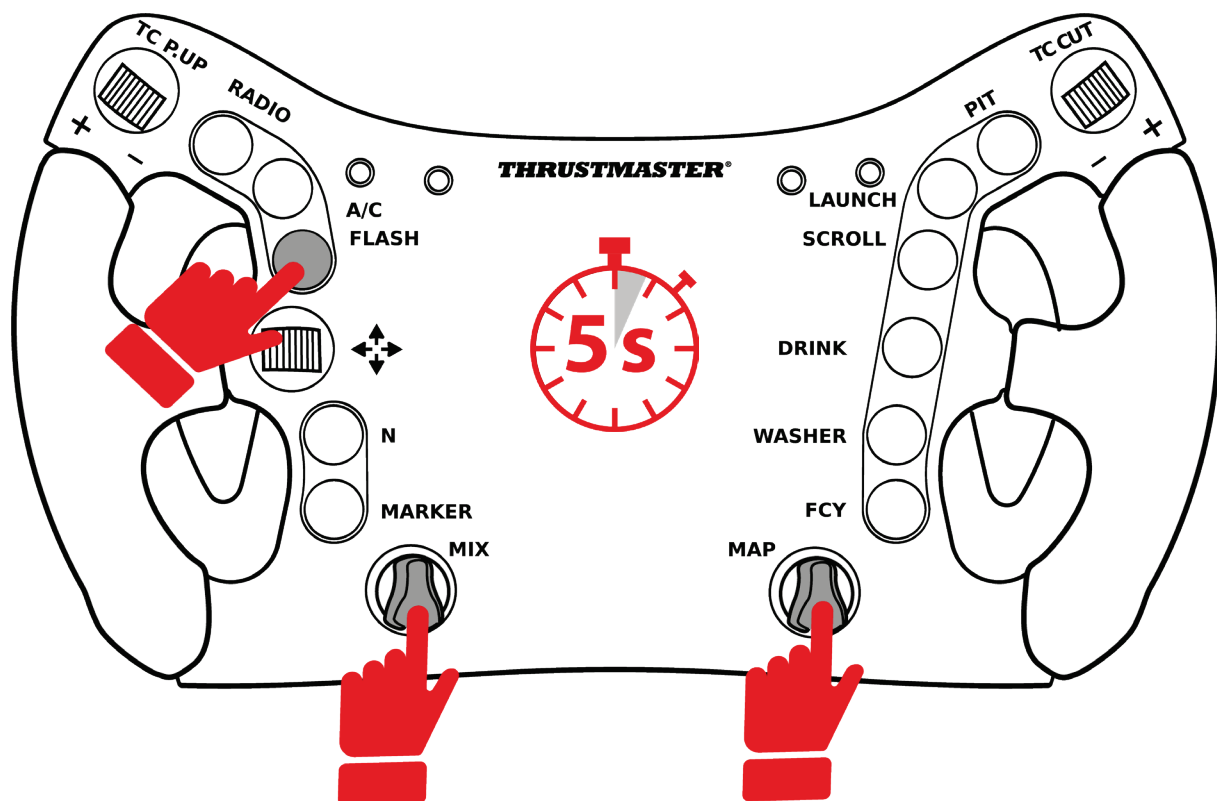

- Öppna LED-menyn genom att trycka samtidigt på **FLASH**-knappen och båda de **vridbara encodrarna** i **5 sekunder**, och släpp dem sedan.
- Stäng LED-menyn genom att trycka samtidigt på **FLASH**-knappen och båda de **vridbara encodrarna**, och släpp dem sedan.



FLAG

RPM

PIT



Öppna LED-menyn: FLAG- och PIT-lamporna och en av varvtalslamporna (röd till vänster eller blå till höger) tänds.



Stäng LED-menyn: alla fyra LED-lampor släcks.



Justera LED-lampornas intensitet

- Öppna LED-menyn genom att trycka samtidigt på **FLASH**-knappen och båda de **vridbara encodrarna** i 5 sekunder och släpp dem sedan.
- Vrid **vänster encoder (MIX)** åt vänster för att sänka intensiteten eller till höger för att öka den.

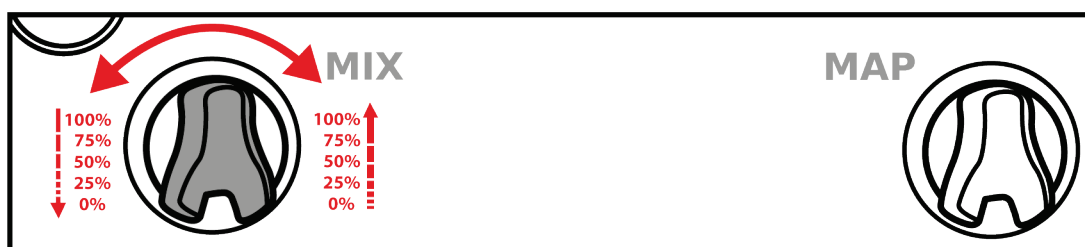

- Stäng LED-menyn genom att trycka samtidigt på **FLASH**-knappen och båda de **vridbara encodrarna**, och släpp dem sedan.



Ändra LED-läge: GT3 eller Formula

- Öppna LED-menyn genom att trycka samtidigt på **FLASH**-knappen och båda de **vridbara encodrarna** i **5 sekunder** och släpp dem sedan.
- Vrid **höger encoder (MAP)** åt vänster för att välja GT3-läget (röd lampa) eller åt höger för att välja Formula-läget (blå lampa).



GT3-läge (standardläget)



FORMULA-läge

- Stäng LED-menyn genom att trycka samtidigt på **FLASH**-knappen och båda de **vridbara encodrarna**, och släpp dem sedan.



7. Anpassa växelpaddlarna

Växelpaddlarna på **Ferrari 488 GT3 Wheel Add-On** kan justeras vad gäller **mellanrum** och **räckvidd**.

Mellanrum innebär att justera växelpaddeln i breddled, vilket modifierar avståndet mellan greppet och växelpaddeln.

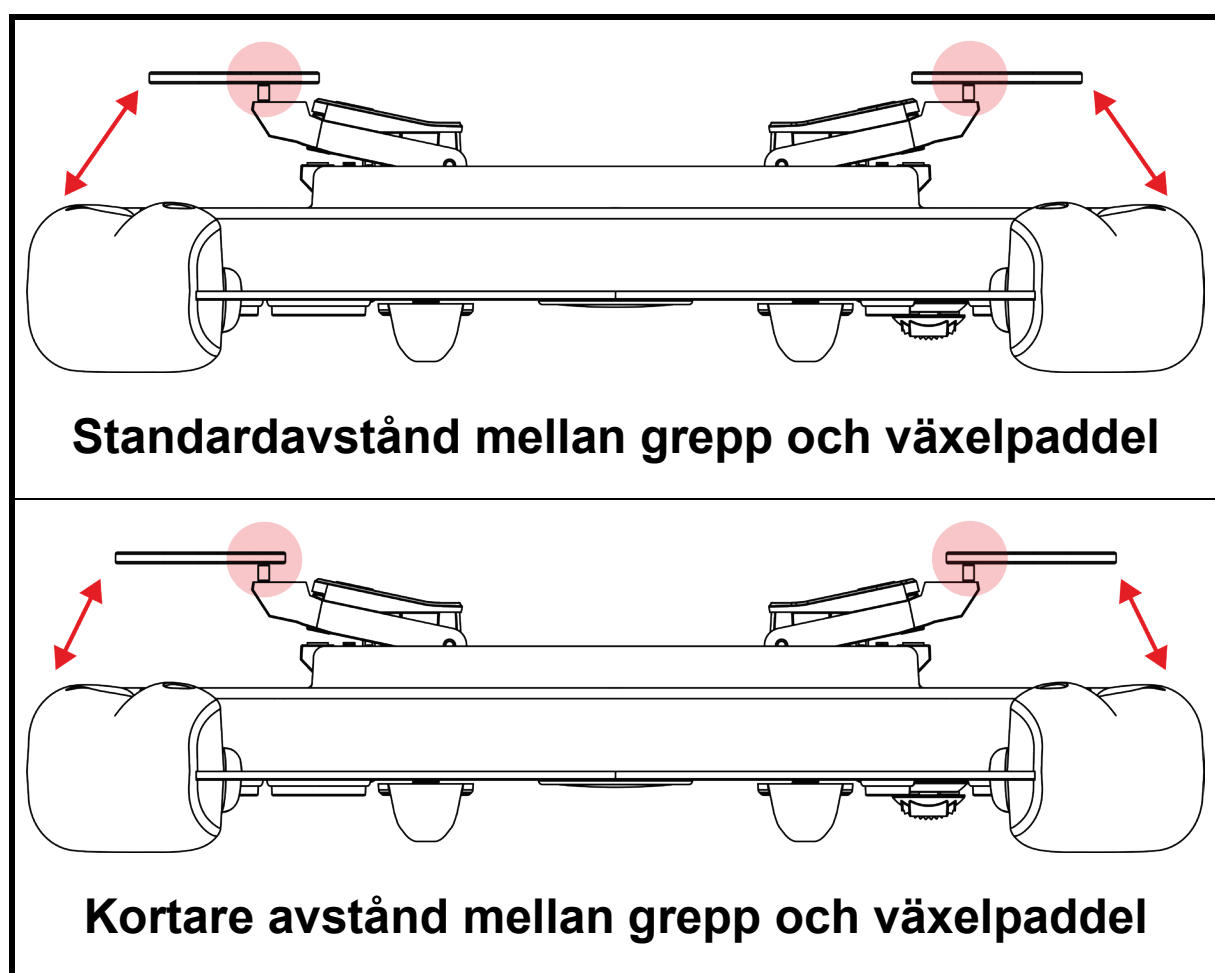



Att justera **räckvidden** med distanserna modifierar växelpaddelns aktiveringsavstånd.

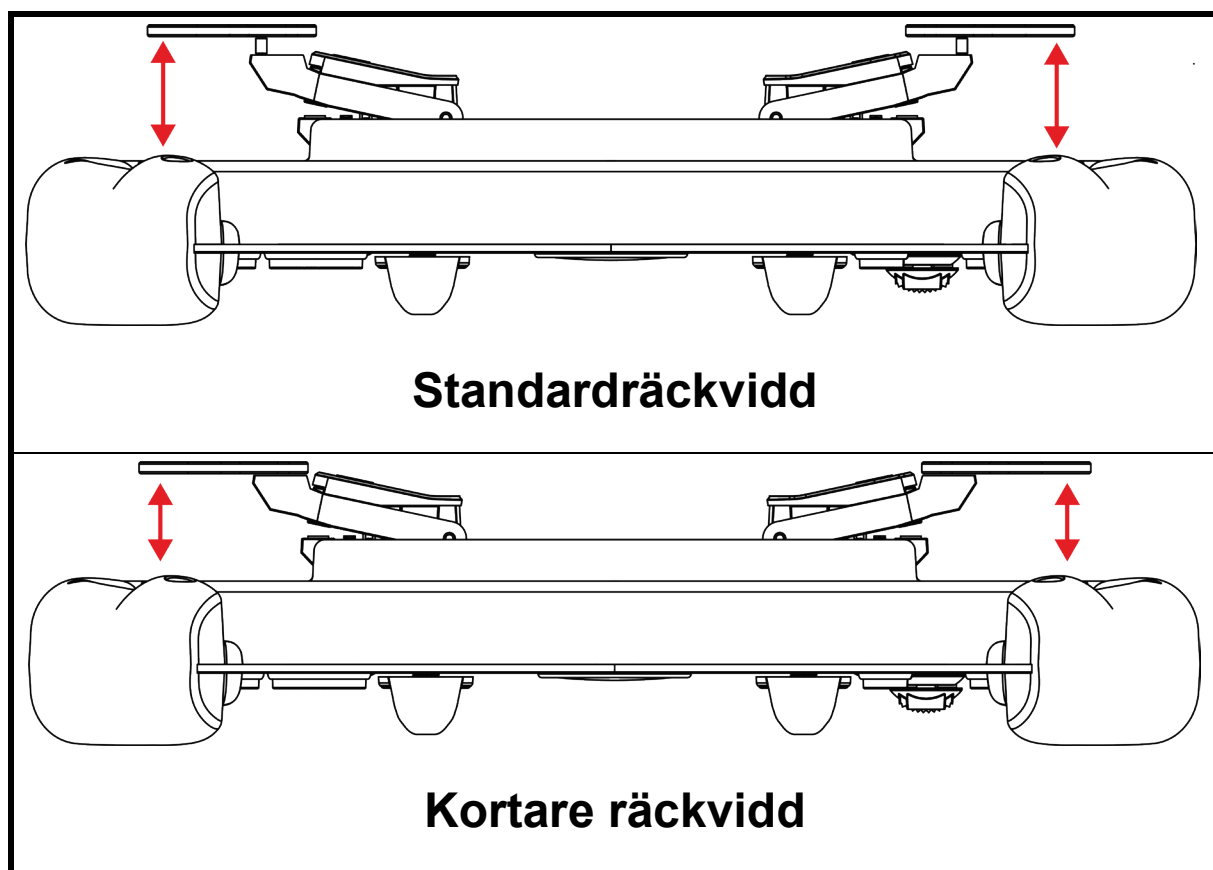

Det går även att justera den **magnetiska känsligheten** och växelpaddlarnas **ljudnivå** med de medföljande kuddarna.

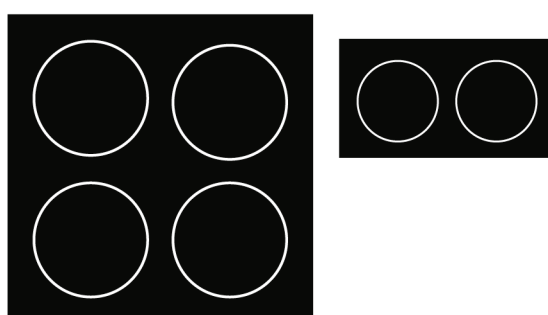



Justera växelpaddlarnas mellanrum

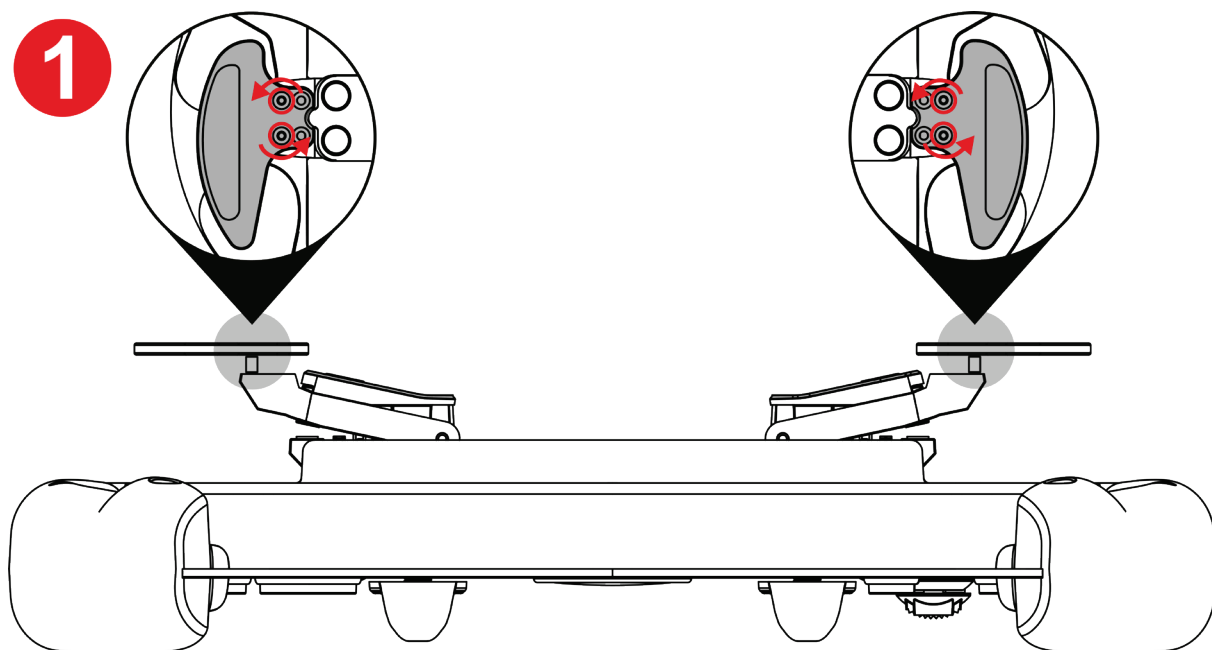

1 Skruva loss de fyra växelpaddelskruvarna med den medföljande Torxnyckeln.

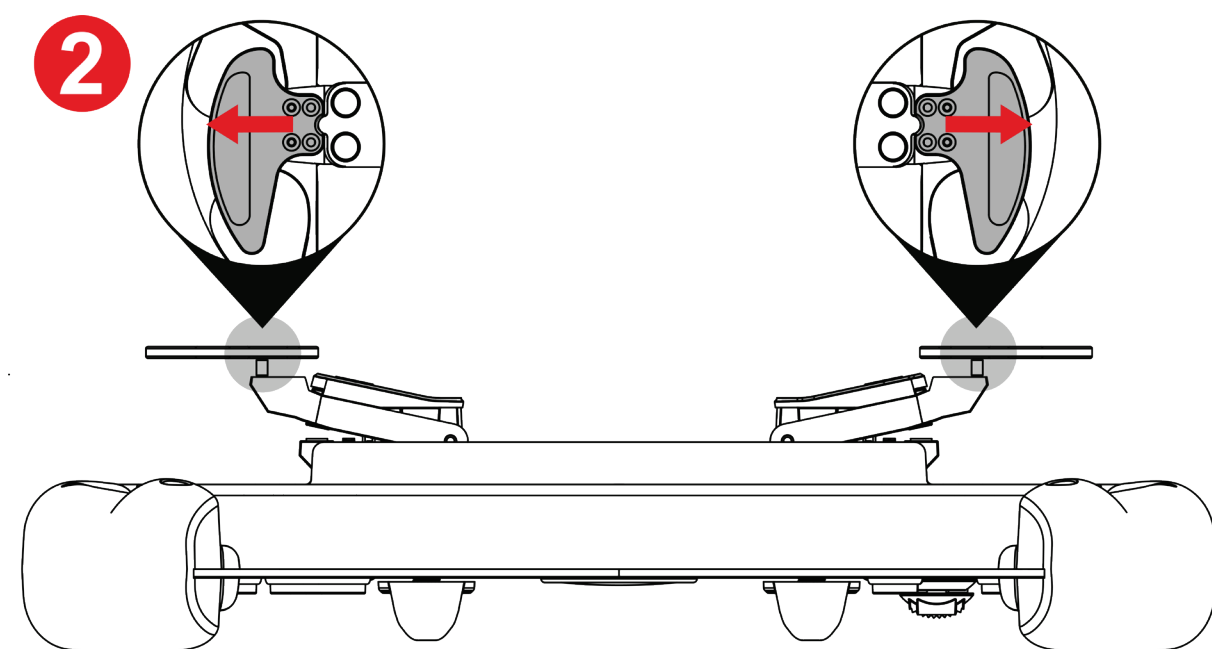

2 Flytta ut växelpaddlarna så de matchar hålen.

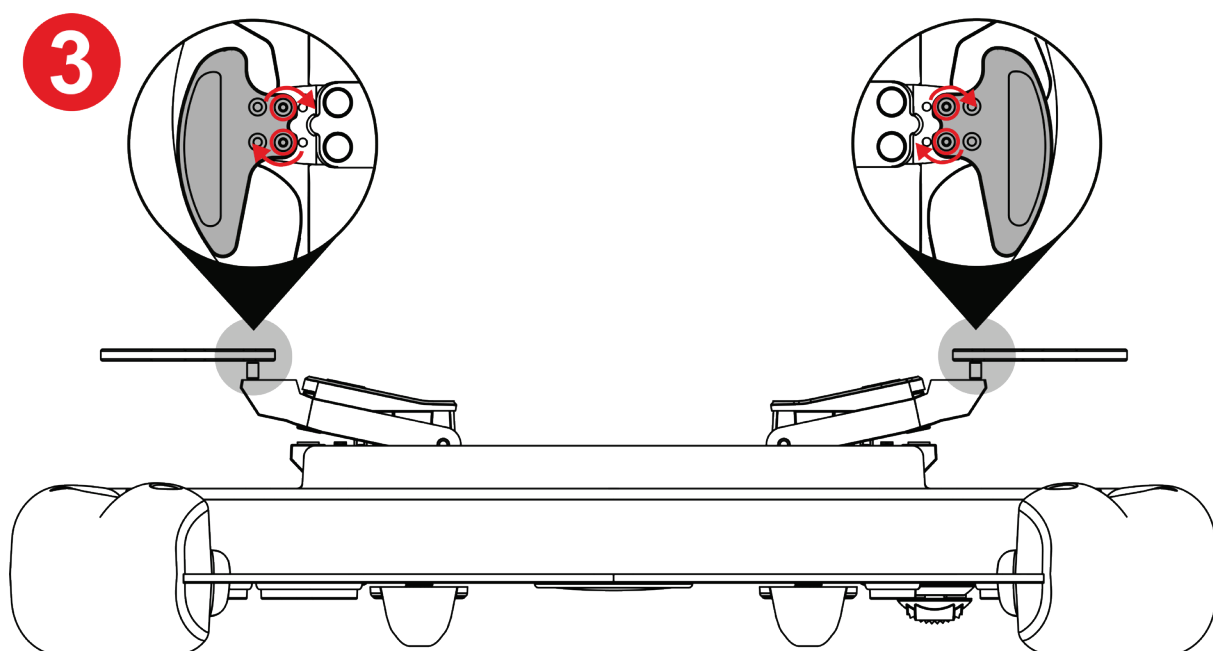

3 Dra åt de fyra växelpaddelskruvarna med den medföljande Torxnyckeln.



Justera växelpaddlarnas räckvidd

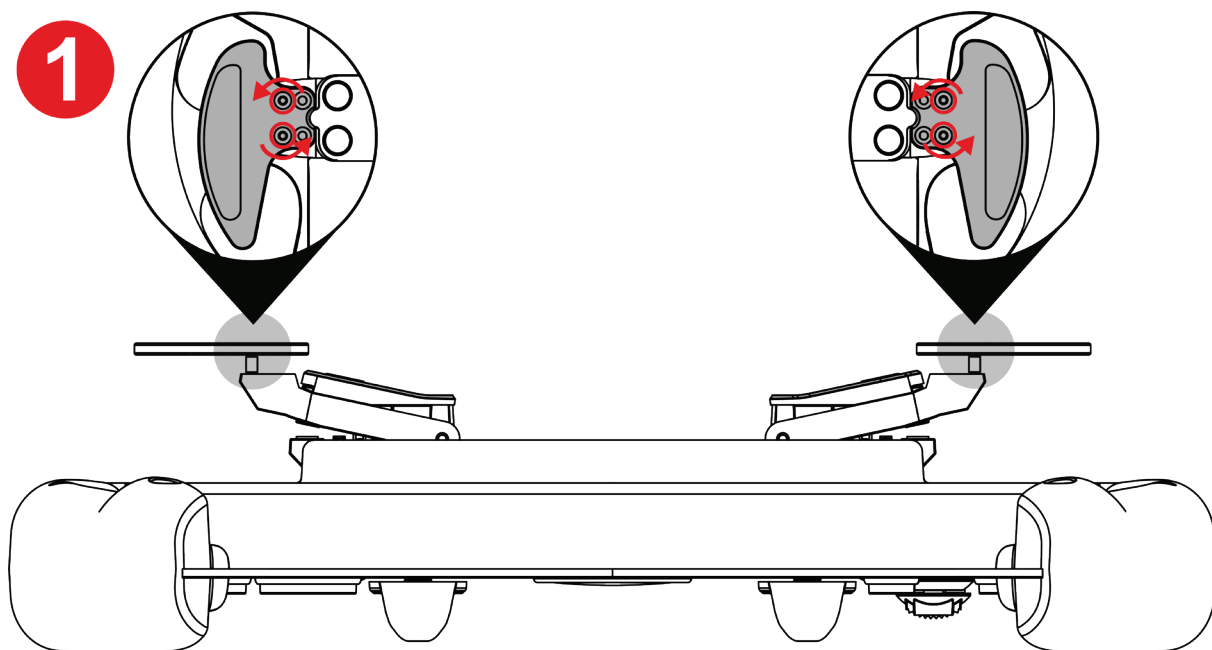

1 Skruva loss de fyra växelpaddelskruvarna med den medföljande Torxnyckeln.

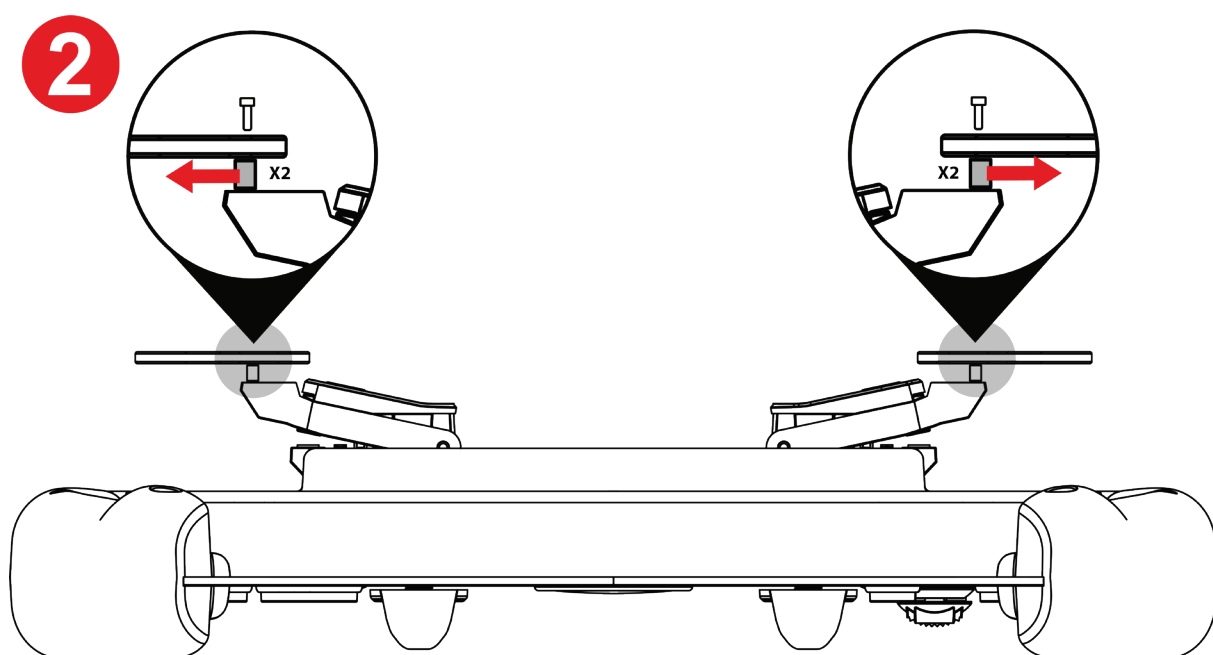

2 Ta bort distanserna.

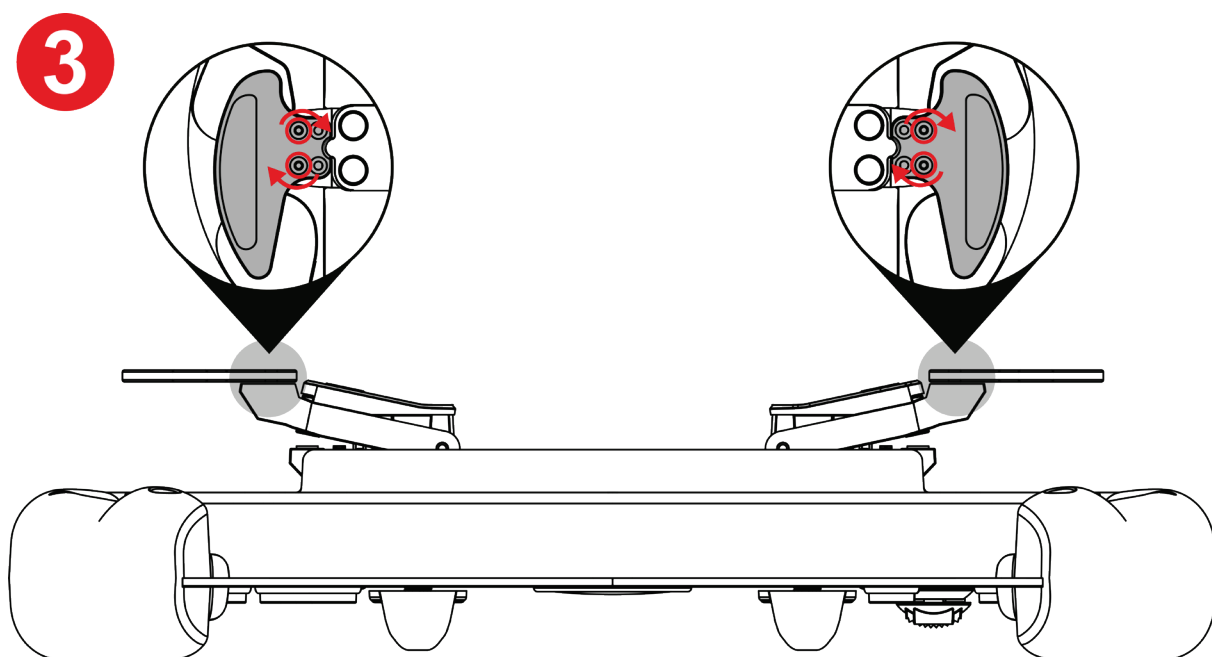

3 Dra åt de fyra växelpaddelskruvarna med den medföljande Torxnyckeln.



Justera växelpaddlarnas magnetiska känslighet och ljudnivå

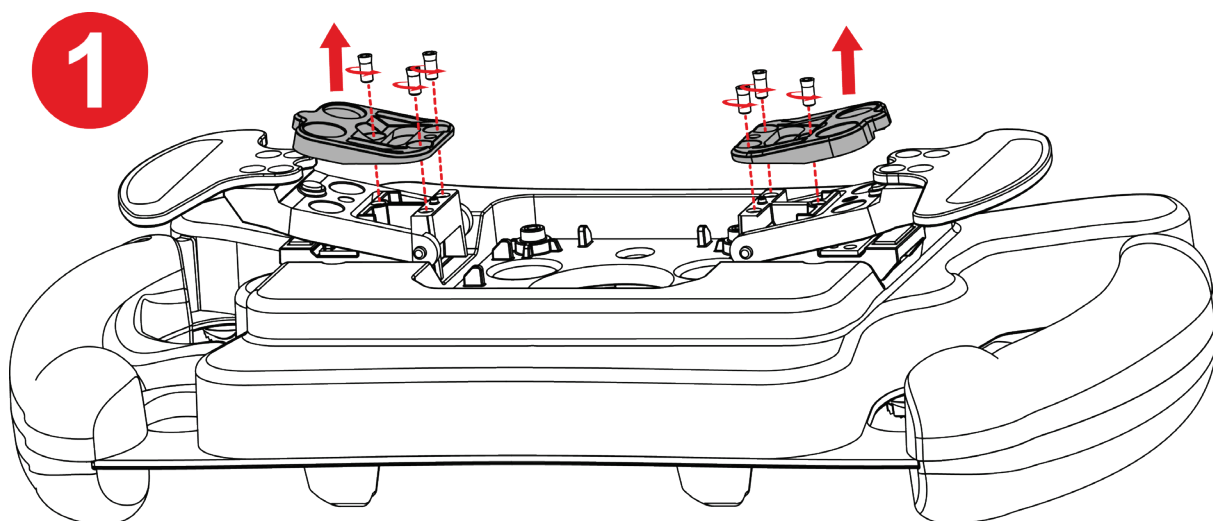

1 Ta bort magnetstoppen genom att skruva loss de sex stoppskruvarna med den medföljande Torxnyckeln.

2

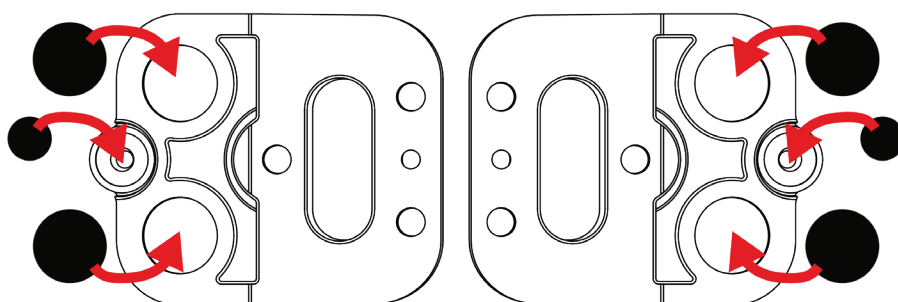
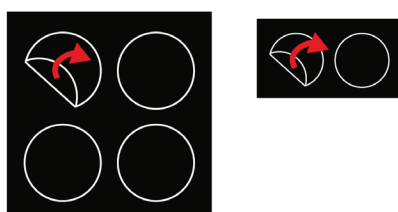

2 Dra av de medföljande kuddarna och fäst dem på lämpliga ställen under magnetstoppen.



Se **Magnetisk känslighet och ljuddämpning av växelpaddlarna (tabell)** för olika konfigurationer och deras effekter.





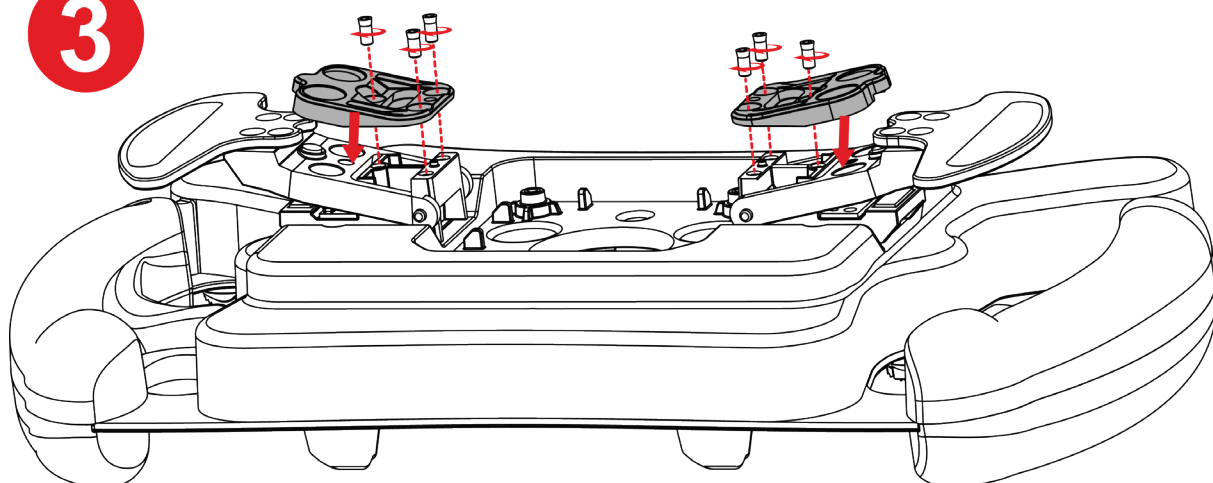

3

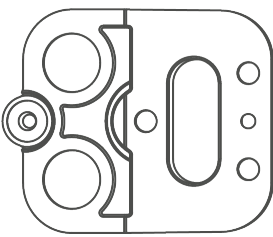
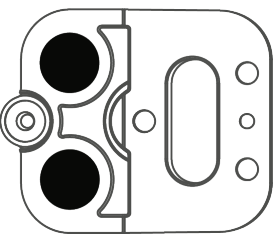
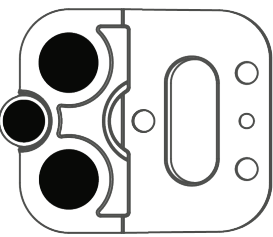

3 Sätt i magnetstoppen igen och dra åt de sex stoppskruvarna med den medföljande Torxnyckeln.

Magnetisk känslighet och ljuddämpning av växelpaddlarna (tabell)

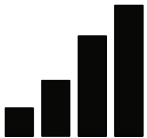
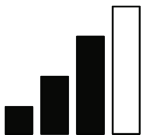
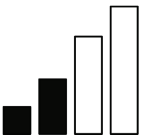
	 (standard)		
Magnetisk känslighet			
Ljud			



8. Vanliga frågor och teknisk support

Har du frågor om Ferrari 488 GT3 Wheel Add-On eller upplever du tekniska problem? Besök då Thrustmasters tekniska supportsida:

<https://support.thrustmaster.com/product/ferrarif488gt3addon>.

På denna sida kan du även uppdatera rattens firmware.



THRUSTMASTER®

FERRARI 488 GT3 WHEEL ADD-ON

PC (Windows 10/11)

PS4™ / PS5™

Xbox Series / Xbox One

Käyttöohje



Lue huolella tästä käyttöohjeesta löytyvät ohjeet, **ennen kuin** asennat tuotteen, **ennen kuin** käytät tuotetta ja **ennen kuin** suoritat mitään huoltoa. Muista noudattaa turvallisuusohjeita. Näiden ohjeiden noudattamattomuus voi johtaa onnettomuuksiin ja/tai vahinkoihin. Pidä tämä käyttöohje tallessa, jotta voit tarkistaa ohjeita myöhemmin.

SISÄLLYSLUETTELO

1.	LAATIKON SISÄLTÖ	5
2.	OMINAISUUDET	6
3.	TIEDOT RATIN KÄYTÖSTÄ	8
4.	PIKAIRROTUSKIINNIKKEEN ASENNUS ..	13
	<i>Salpajalustan pikairrotuskiinnikkeen asennus</i>	<i>14</i>
	<i>Ruuvijalustan pikairrotuskiinnikkeen asennus</i>	<i>17</i>
5.	MÄÄRITYKSET	21
	<i>Määrittymiset – PC.....</i>	<i>21</i>
	<i>Määrittymiset – PS4™/PS5™</i>	<i>22</i>
	<i>Määrittymiset – Xbox Series / Xbox One</i>	<i>23</i>
6.	LED-VALOJEN KÄYTTÖ	24
	<i>LED-valikon käyttö</i>	<i>25</i>
	<i>LED-valojen voimakkuuden säätö.....</i>	<i>27</i>
	<i>LED-tilan vaihto GT3 tai Formula</i>	<i>28</i>

7.	VAIHDEVIVUN MUKAUTUS	29
	<i>Vaihdevivun etäisyyden säätö</i>	<i>31</i>
	<i>Vaihdevivun liikkeen säätö.....</i>	<i>33</i>
	<i>Vaihdevivun magneettisen herkkyyden ja äänentason säätö</i>	<i>35</i>
8.	UKK JA TEKNINEN TUKI	37



FERRARI 488 GT3 WHEEL ADD-ON

Ole Ferrari 488 GT3 Wheel Add-On -ratin avulla osa GT-legendaa. Se on suunniteltu suorituskykyiseksi ja yhteensopiva kaikkien Thrustmaster-rattiohjainjalustojen kanssa.

Tämä käyttöohje auttaa asentamaan Ferrari 488 GT3 Wheel Add-Onin ja käyttämään sitä parhaissa olosuhteissa. Ennen kuin aloitat kisaamisen, lue huolella nämä ohjeet ja varoitukset: ne auttavat ottamaan kaiken nautinnon irti tuotteesta.



1. Laatikon sisältö

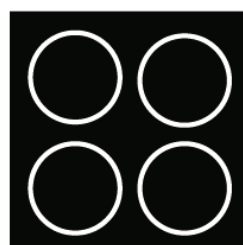
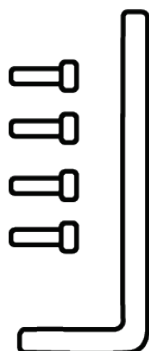
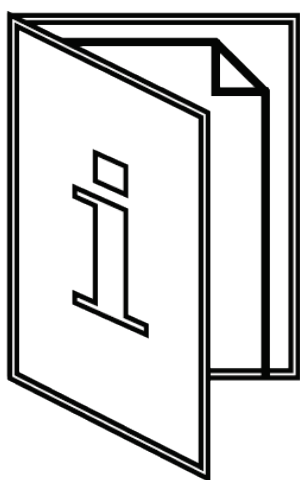
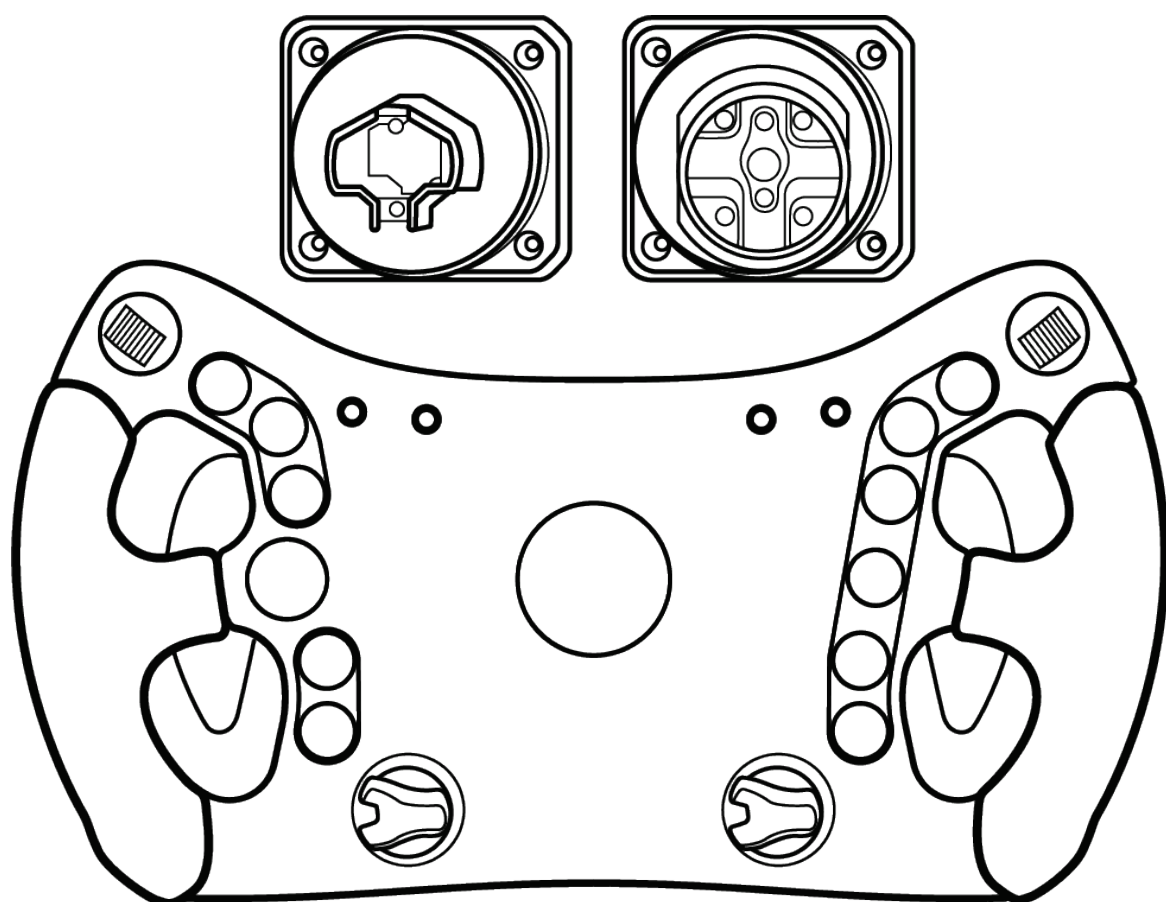



2. Ominaisuudet

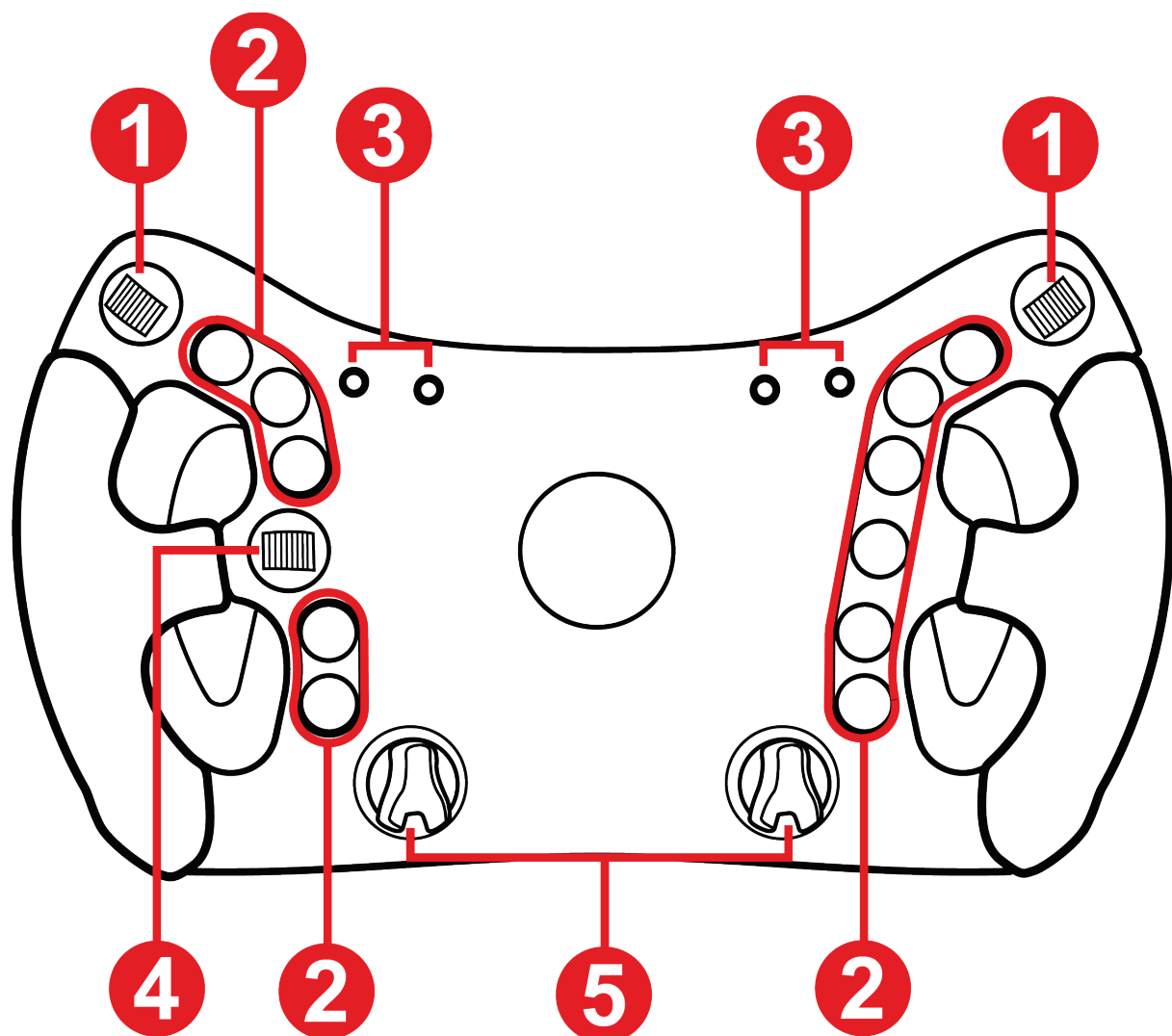

❶ peukalosäätimet

❷ 11 toimintopainiketta

❸ RPM-valot ja kisatiedot (liput, varikko)

❹ suuntaohjain

❺ säätönupit

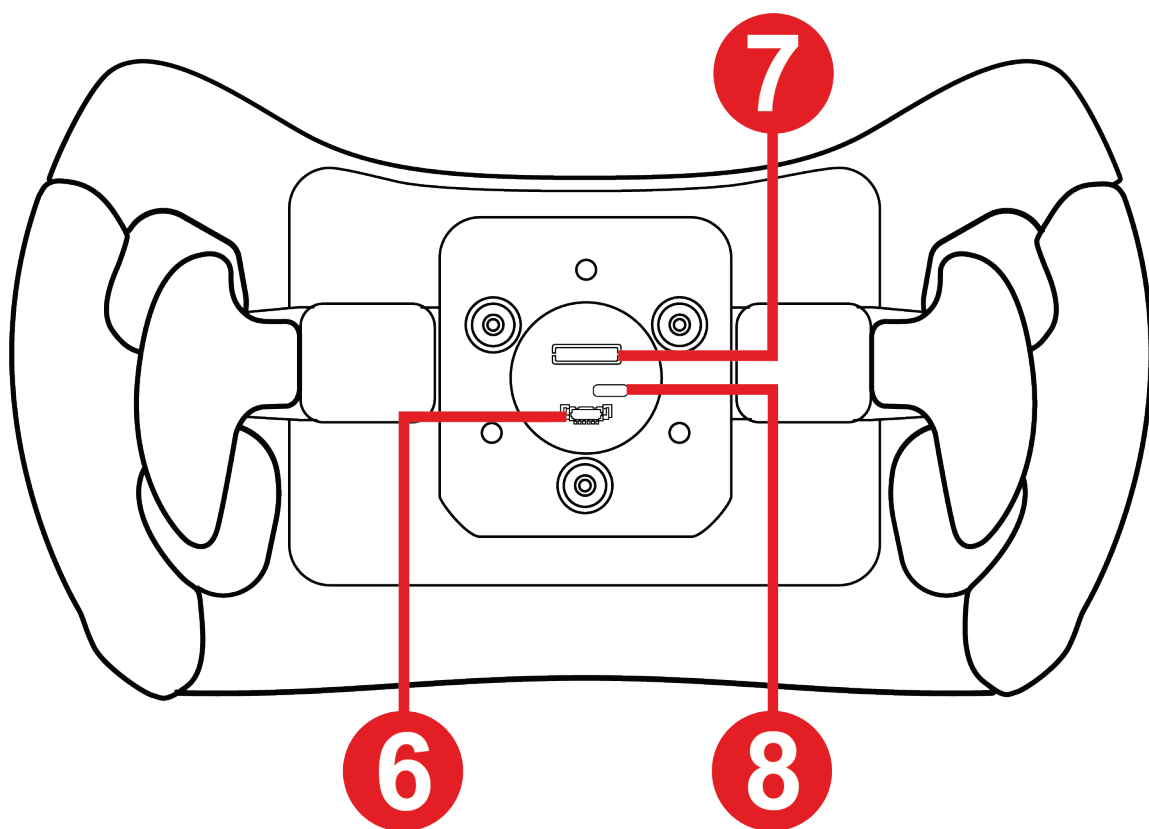

- ⑥ liitinportti ruuvijalustan pikairrotuskiinnikkeelle
- ⑦ liitinportti salpajalustan pikairrotuskiinnikkeelle
- ⑧ USB-C-portti (laiteohjelmiston päivitystä varten, kaapeli ei tule mukana)

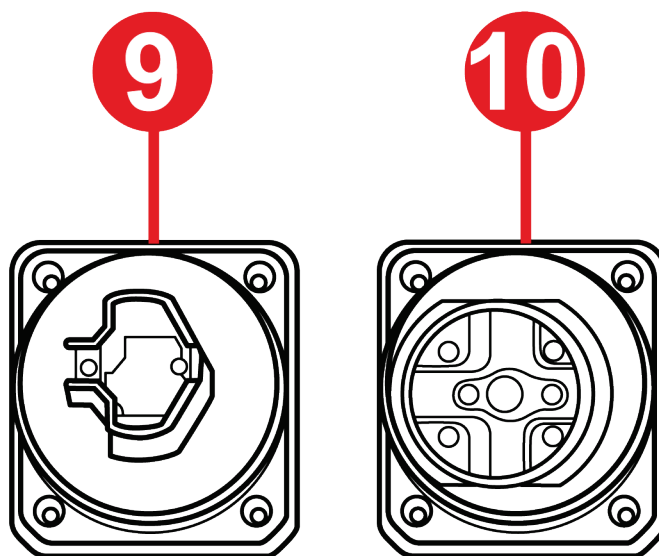

- ⑨ pikairrotuskiinnike salpajalustalle
- ⑩ pikairrotuskiinnike ruuvijalustalle



3. Tiedot ratin käytöstä



Ohjekirja

Lue tämä ohjekirja huolella ennen tuotteen käyttöä ja säilytä se vastaisuuden varalle.



Sähköisku

- Pidä tuote kuivassa paikassa, älä altista sitä pölylle tai auringonvalolle.
- Älä väännä tai vedä liittimiä tai kaapeleita.
- Seuraa liitinten napaisuuksia.
- Älä kaada nestettä tuotteen tai sen liitinten päälle.
- Älä aiheuta tuotteelle oikosulkua.
- Älä pura tuotetta (pois lukien tässä ohjekirjassa mainitut mukautukset); älä heitä tuotetta tuleen tai altista sitä korkeille lämpötiloille.
- Älä avaa laitetta: sisällä on osia, jotka eivät ole käyttäjien huollettavissa. Kaikista huolloista vastaa valmistaja, sen ennalta määritetty edustaja tai pätevä asentaja.



Pelialueen varmistaminen

- Älä aseta mitään esinettä pelialueelle, joka voi häiritä käyttäjän toimintaa, aiheuttaa sopimattomia liikkeitä tai johtaa toisen henkilön aiheuttamaan häiriöön (esimerkiksi kahvimuki, puhelin tai avaimet).
- Älä peitä virtajohtoja matolla, viltillä, peitolla tai muulla esineellä, äläkä sijoita johtoja minnekään, mistä ihmiset kävelevät.



Ohjauspalautteen ja toistuvan liikkeen aiheuttamat vammat

Rattiohjaimen ohjauspalautteen käyttäminen voi johtaa lihas- tai nivelkipuihin. Välttääksesi mahdolliset ongelmat:

- Lämmittele etukäteen ja vältä pitkää käyttöä.
- Vietä 10–15 minuutin tauko jokaisen käyttötunnin jälkeen.
- Mikäli tunnet väsymystä tai kipua käsissäsi, ranteissasi, säärissäsi tai jaloissasi, sammuta ohjauspalautte painamalla painiketta, sammuta jalusta ja lepää muutaman tunnin ajan, ennen kuin aloitat käytön uudelleen.
- Mikäli yllä kuvatut oireet tai kivut jatkuvat aloittaessasi käytön uudelleen, lopeta käyttö ja kysy neuvoa lääkäriltä.
- Älä aseta ohjauspalautetta tasolle, joka on liian korkea taitoihisi ja fyysiseen kuntoosi nähden.
- Pidä tuote alle 16-vuotiaiden ulottumattomissa.
- Varmista, että jalusta ja ratti on kiinnitetty kunnolla käyttöohjeessa esitetyllä tavalla.



Odottamattoman, voimakkaan ja nopean pyörimisliikkeen riski: Älä ikinä aseta kättä tai käsivartta ratin aukkojen läpi tai sen kääntöradalle.

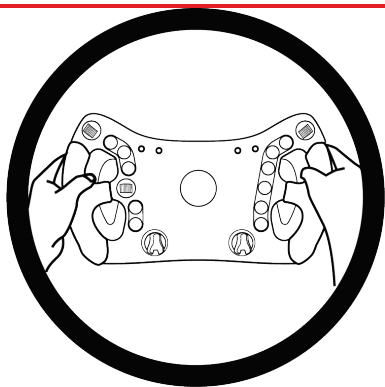

Pidä käytön aikana molemmat kädet oikeassa kohdassa rattia päästämättä koskaan kokonaan irti.



Tuote on tarkoitettu vain vähintään **16-vuotiaille** käyttäjille.



4. Pikairrotuskiinnikkeen asennus

Ferrari 488 GT3 Wheel Add-On sisältää kaksi Thrustmasterin jalustamalleja vastaavaa pikairrotuskiinnikettä.

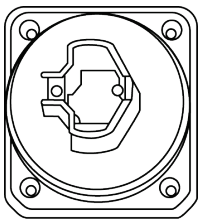
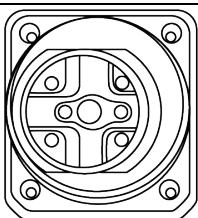
Järjestelmä	Yhteensopivuus
 Pikairrotuskiinnike salpajalustalle	T818, T818 Ferrari SF1000 Simulator ja tulevat Thrustmaster-jalustat.
 Pikairrotuskiinnike ruuvijalustalle	T-GT / T-GT II Servo Base, T300 RS Servo Base, TS PC Racer, TS-XW, TX Racing Wheel Servo Base ja TS-XW Servo Base.



Varmista ennen jokaista **Ferrari 488 GT3 Wheel Add-On** -rattiohjaimen käyttökertaa, että se on edelleen kiinnitetty kunnolla tukeen jalustan käyttöohjeessa esitetyllä tavalla.



Salpajalustan pikairrotuskiinnikkeen asennus

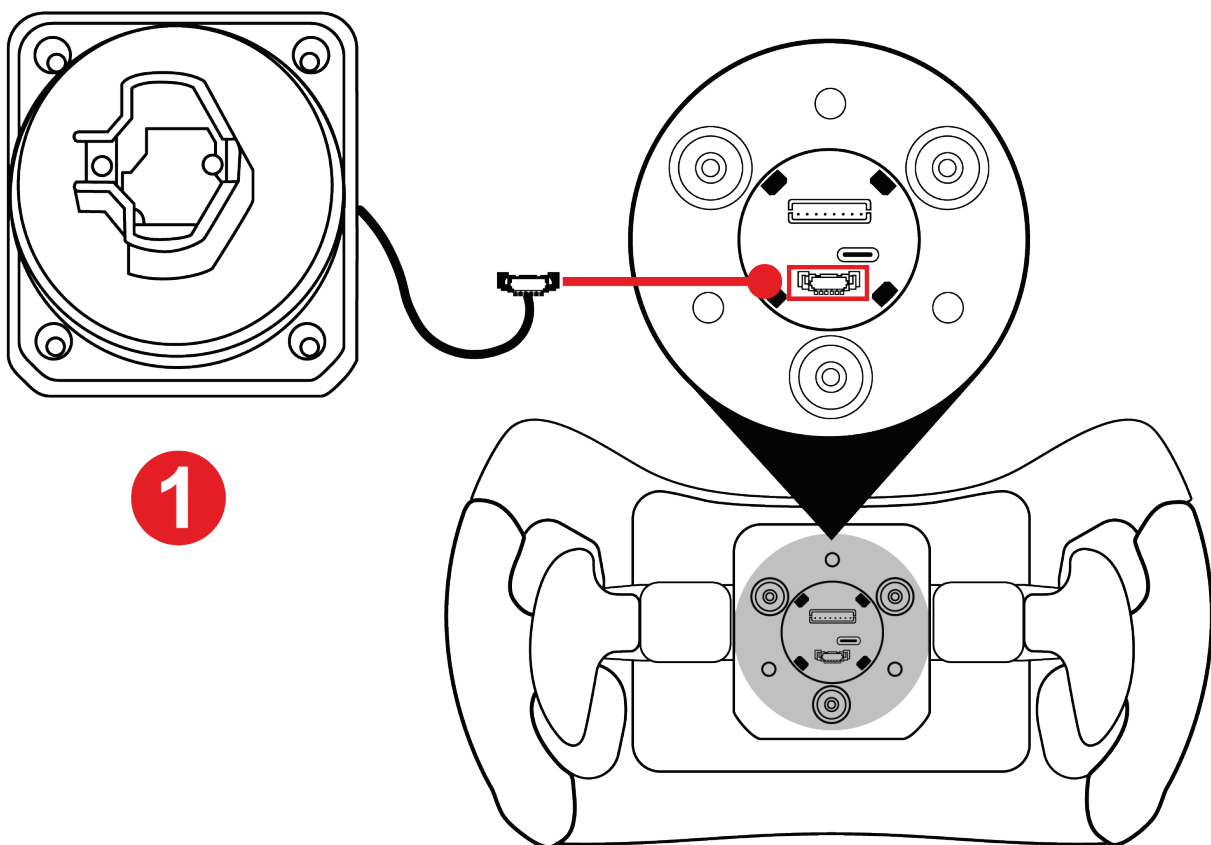

1

1 Aseta pikairrotuskiinnikkeen liitin sitä vastaavaan ratin takaa löytyvään porttiin.



Jotta vältät kaapelin puristumisen, vedä se koteloonsa ennen kiinnikkeen ruuvaamista.

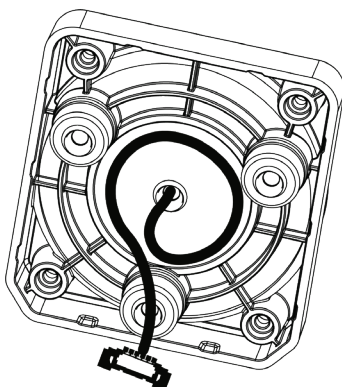

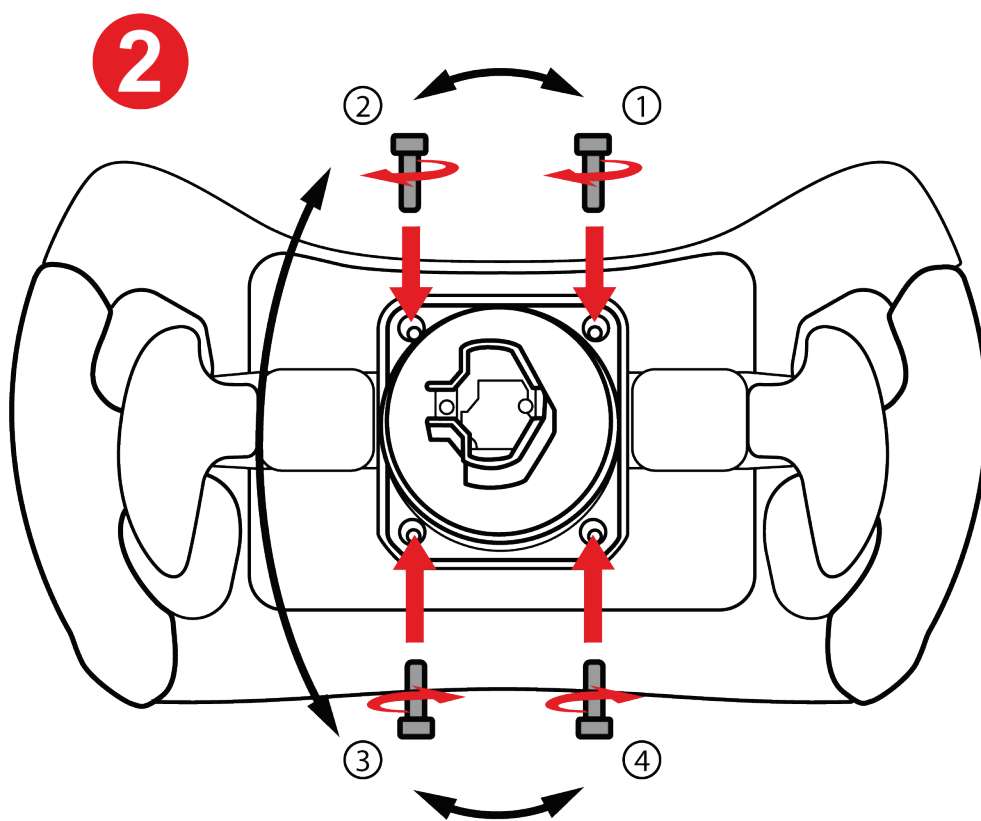

2 Aseta pikairrotuskiinnike ja kiristä se mukana tulevalla Torx-avaimella.



Älä ylikiristä ruuveja asettaessasi kiinnikettä.

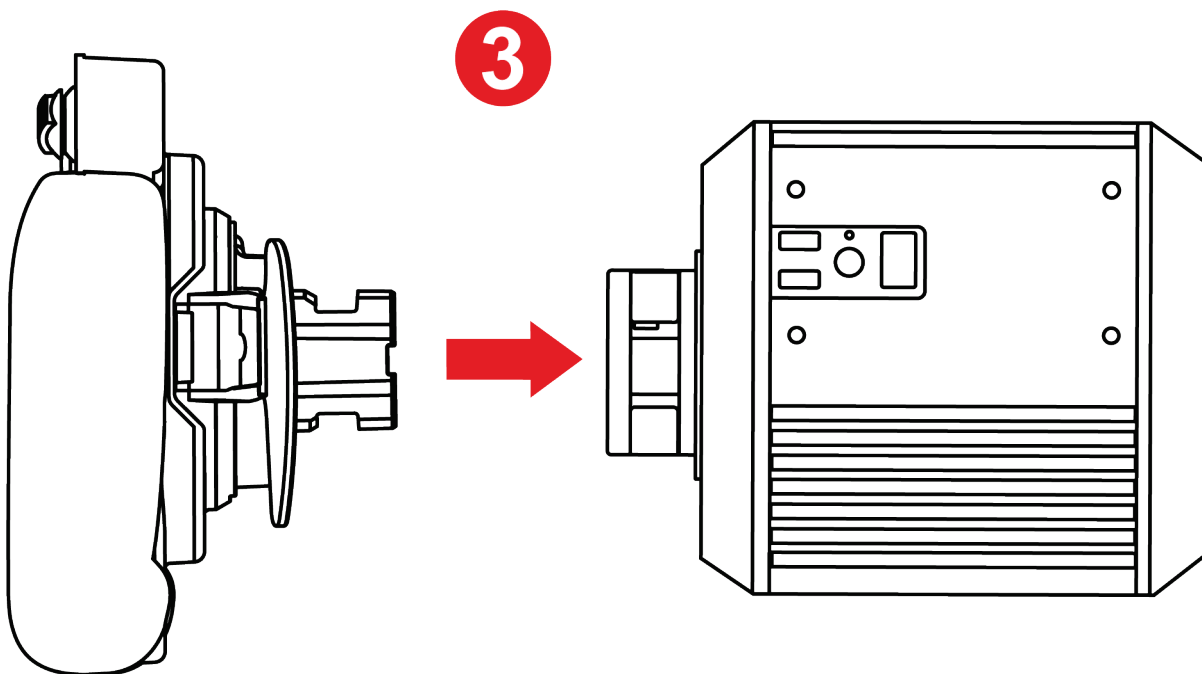

3 Aseta ratti jalustaan.



Seuraa jalustan käyttöohjeessa määritettyjä asennustoimia.



Ruuvijalustan pikairrotuskiinnikkeen asennus

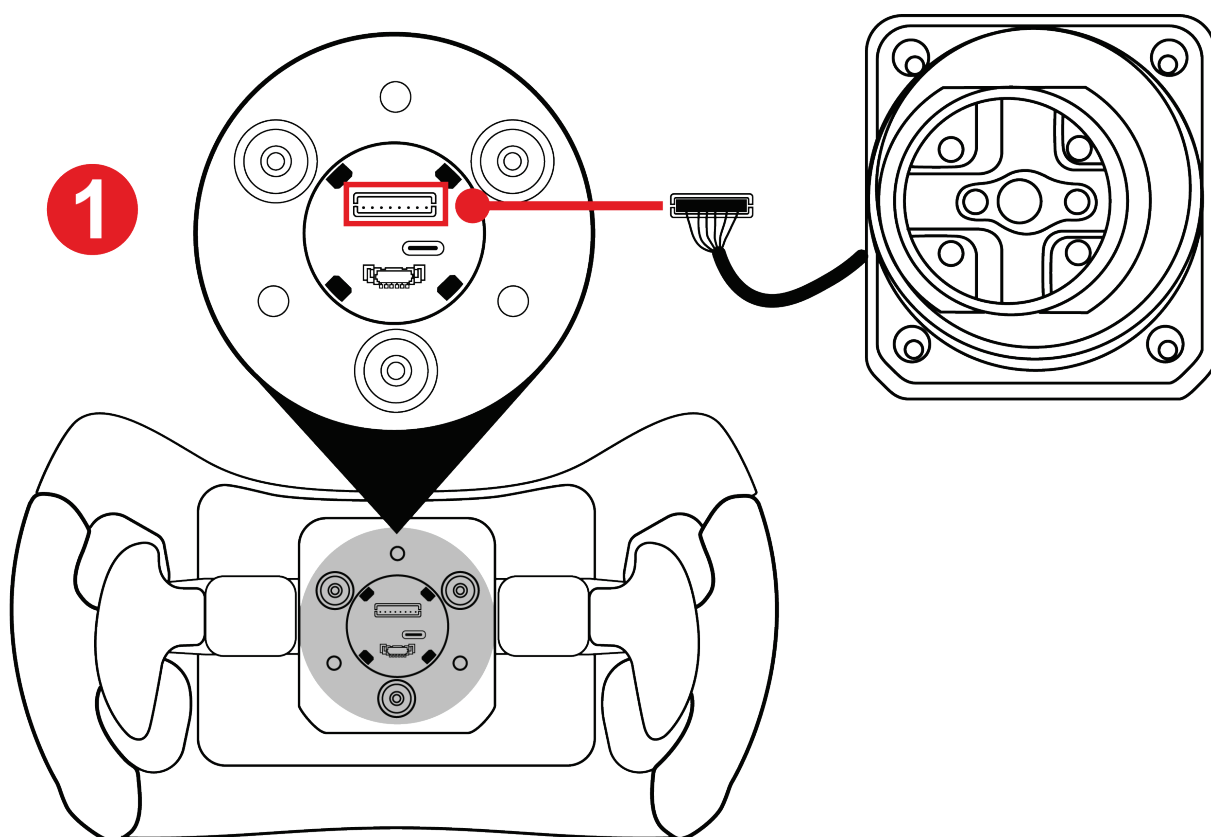

1 Aseta pikairrotuskiinnikkeen liitin sitä vastaavaan ratin takaa löytyvään porttiin.



Jotta vältät kaapelin puristumisen, vedä se koteloonsa ennen kiinnikkeen ruuvaamista.

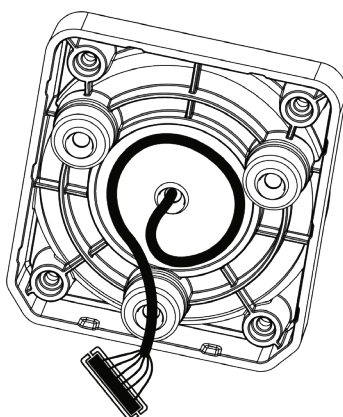

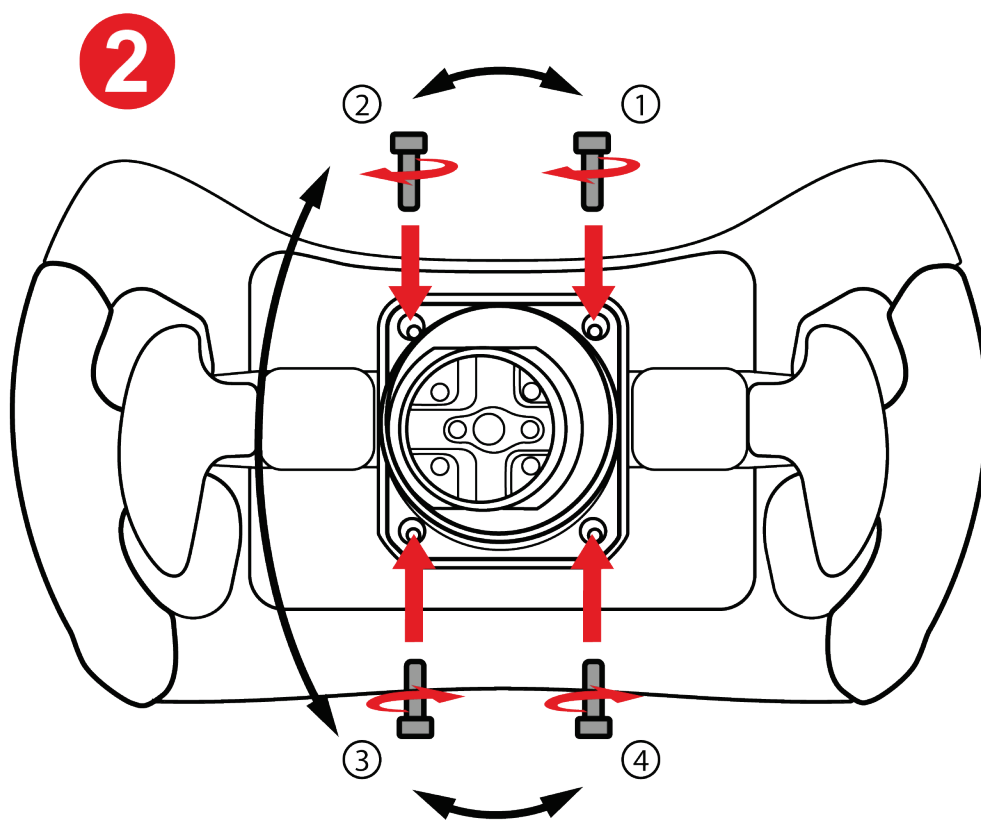

2 Aseta pikairrotuskiinnike ja kiristä se mukana tulevalla Torx-avaimella.



Älä ylikiristä ruuveja asettaessasi kiinnikettä.

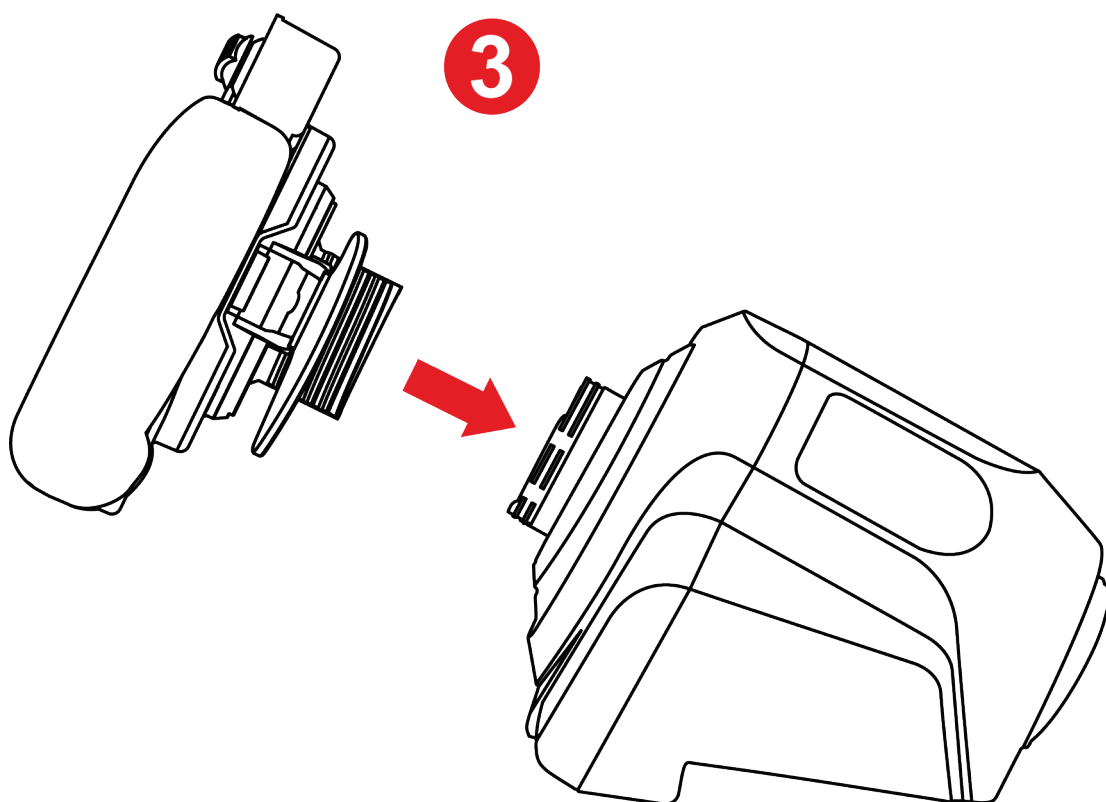

3 Aseta ratti jalustaan.



Seuraa jalustan käyttöohjeessa määritettyjä asennustoimia.



Älä ikinä yhdistä Quick Release Adapteria (tulee T818-jalustan mukana ja myydään erikseen) ruuvijalustan pikairrotuskiinnikkeeseen, mikäli aiot käyttää T818-jalustaa.

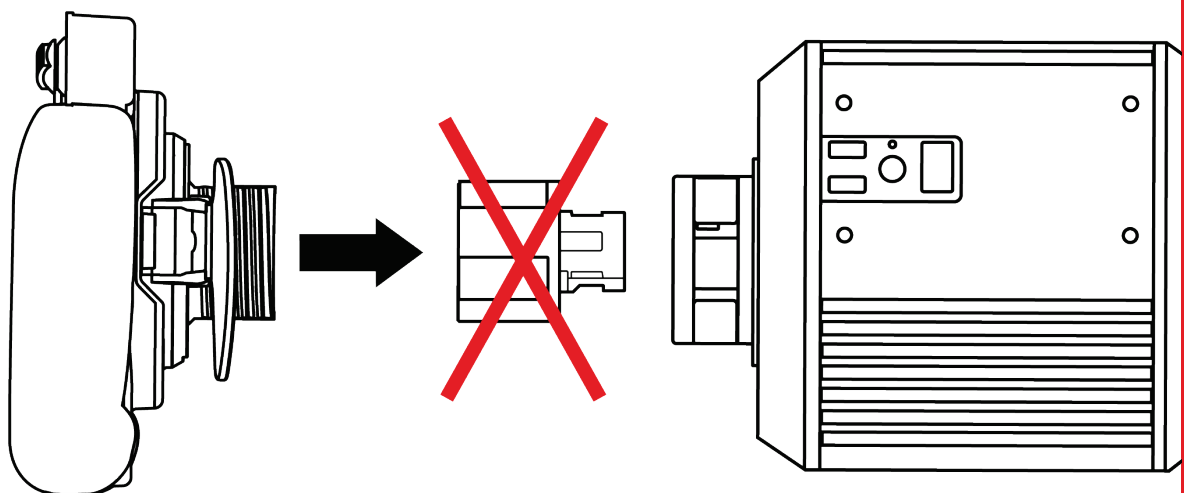
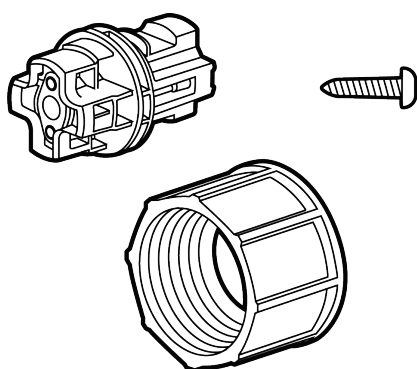

Käytä T818-jalustan tai salpajalustaliittimellä varustetun jalustan kanssa vain **salpajalustan pikairrotuskiinnikettä**, joka tulee **Ferrari 488 GT3 Wheel Add-On** -rattiohjaimen mukana.



5. Määritykset

Määritykset – PC

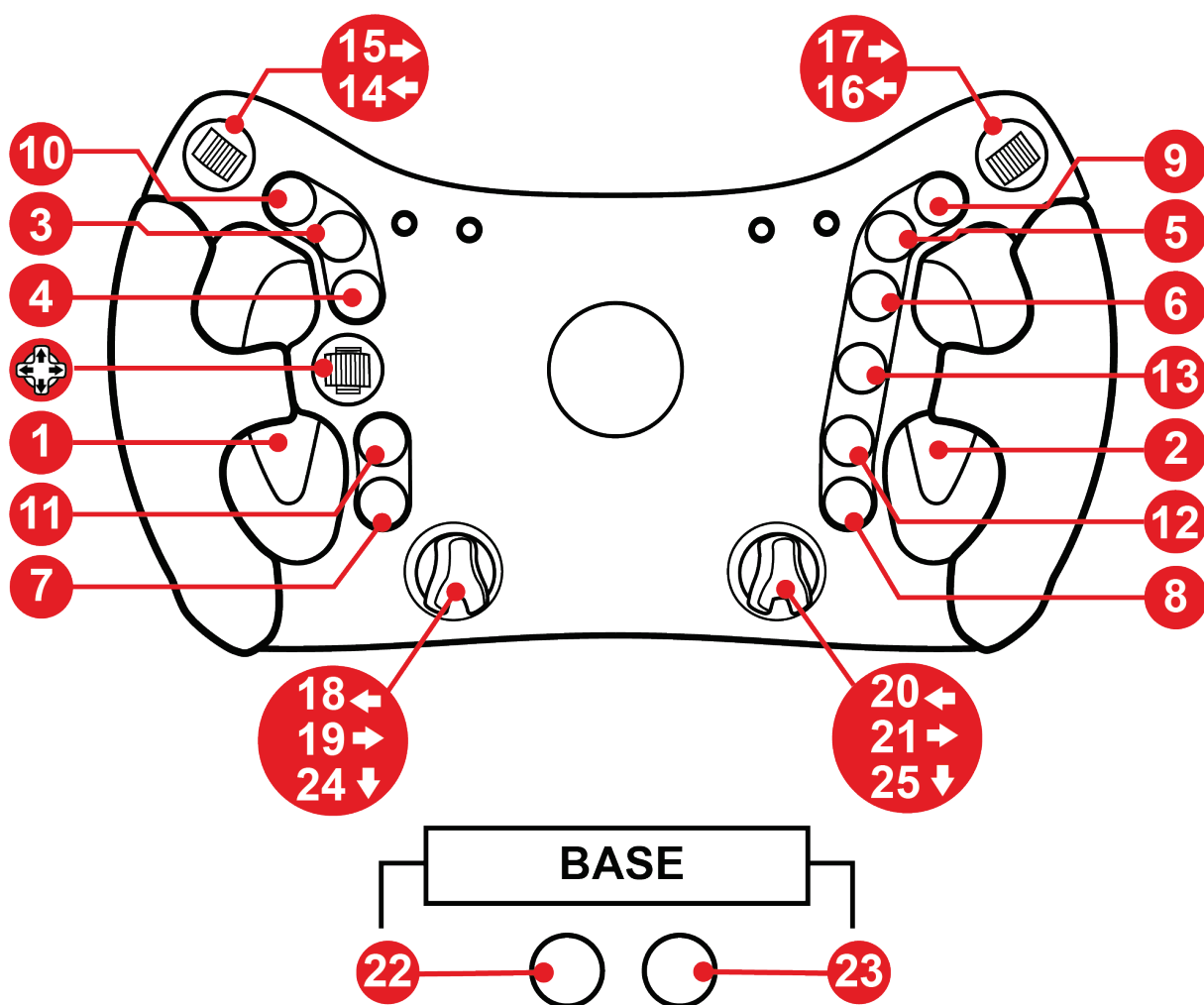



Määrittelykset – PS4™/PS5™

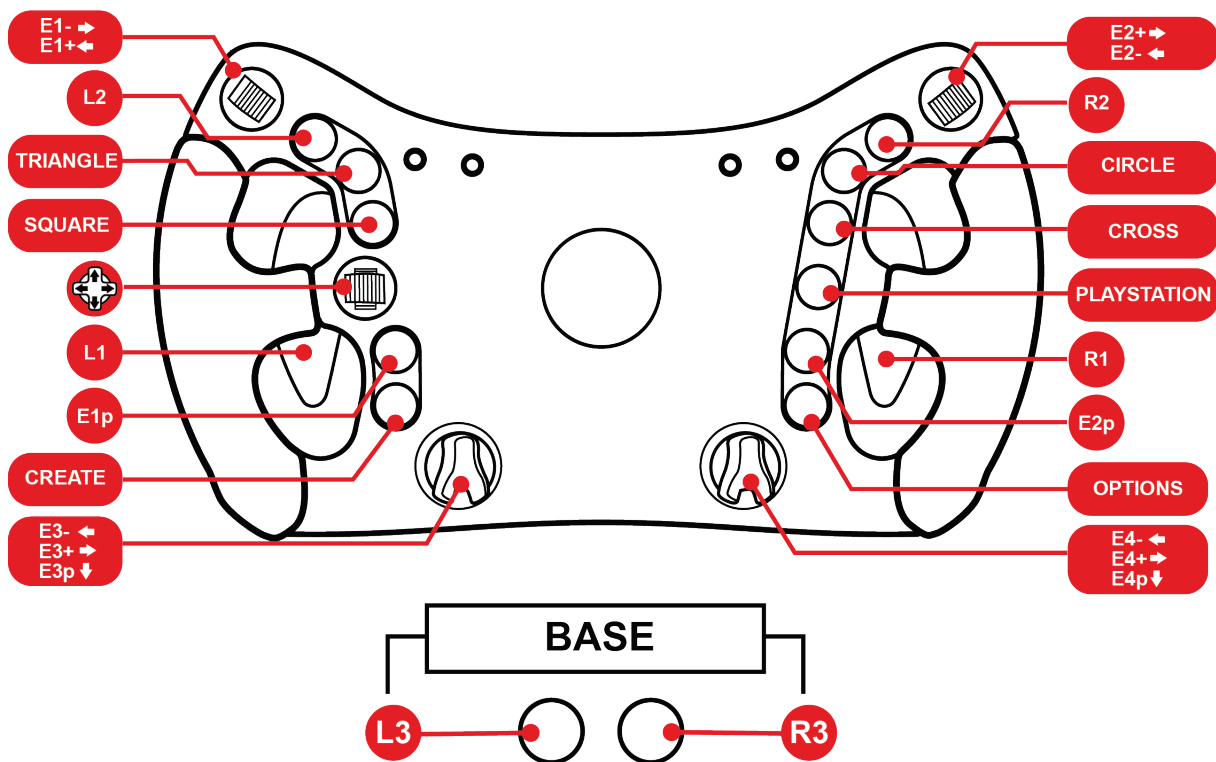



Määritykset – Xbox Series / Xbox One

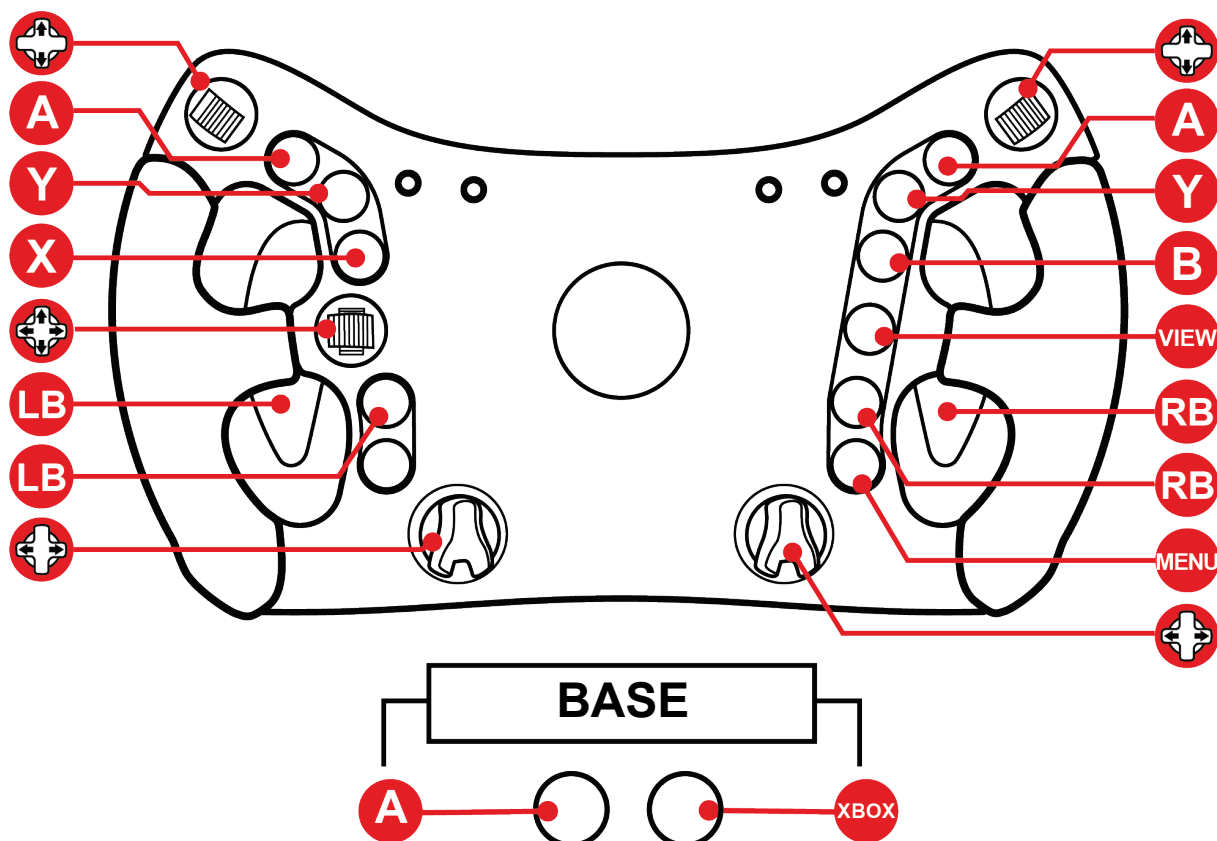

Xbox Seriesillä ja Xbox Onella:

- Ferrari 488 GT3 Wheel Add-Onin LED-valot eivät ole käytössä konsolin protokollarajoitusten vuoksi.
- Osa toiminnoista (säätimet ja painikkeiden määrä) ovat konsolin protokollien rajoittamia.



6. LED-valojen käyttö

Ferrari 488 GT3 Wheel Add-On esittää kisatietoja LED-valoilla: lippu, varikko ja RPM-luku.

Esitettyjä tietoja voi muokata (RPM-valojen voimakkuus ja väri) tilasta riippuen (GT3 tai Formula).

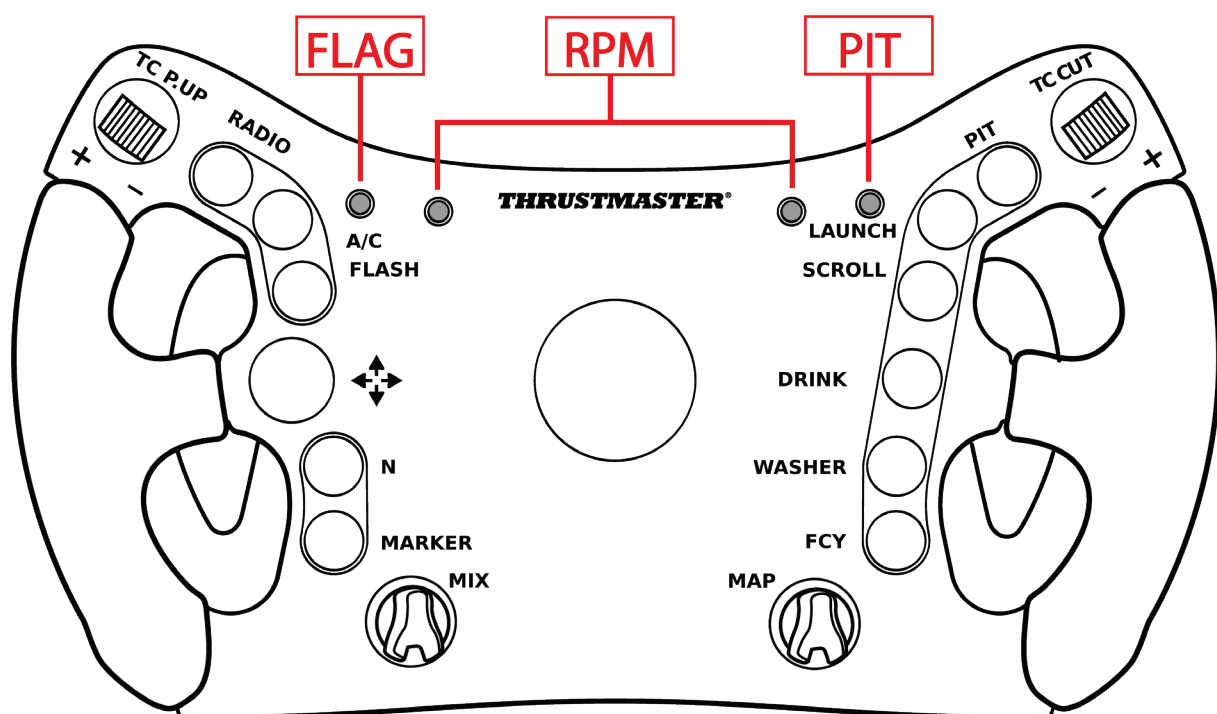

LED-valot ovat käytössä PC:llä ja PS4™-/PS5™-konsolilla.

Xbox Seriesillä ja Xbox Onella LED-valot eivät ole käytössä konsolin protokollarajoitusten vuoksi.



LED-valikon käyttö

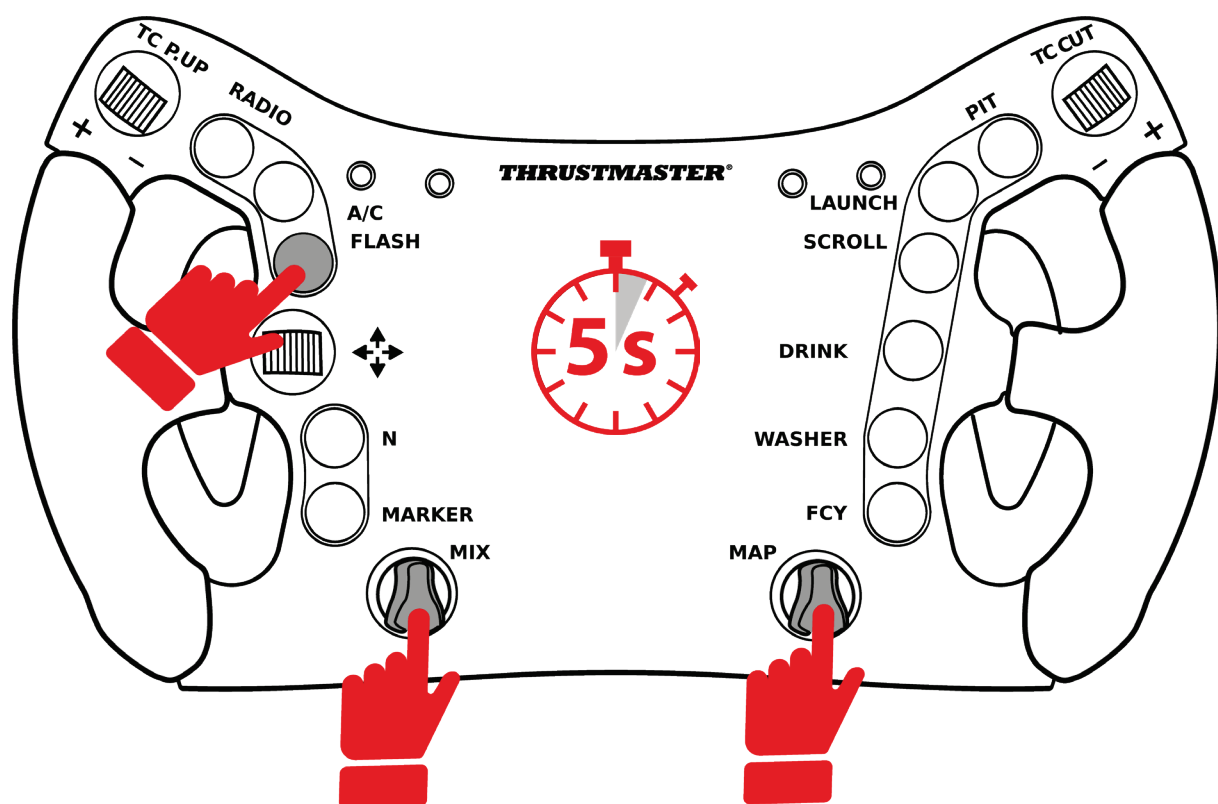

– Siirry LED-valikkoon painamalla yhtä aikaa **FLASH-**painiketta sekä molempia **säätönuppeja 5 sekunnin ajan** ja vapauttamalla sitten ne.

– Poistu LED-valikosta painamalla yhtä aikaa **FLASH-**painiketta sekä molempia **säätönuppeja** ja vapauttamalla sitten ne.



FLAG

RPM

PIT



Siirry LED-valikkoon: FLAG- ja PIT-valot ja yksi RPM-valoista (punainen vasemmalta tai sininen oikealta) syttyvät.



Poistu LED-valikosta: kaikki neljä LED-valoa sammuvat.



LED-valojen voimakkuuden säätö

- Siirry LED-valikkoon painamalla yhtä aikaa **FLASH-**painiketta sekä molempia **säätönuppeja 5 sekunnin ajan** ja vapauttamalla sitten ne.
- Käännä **vasenta säätönuppia (MIX)** vasemmalle vähentääksesi voimakkuutta tai oikealle kasvattaaksesi sitä.



- Poistu LED-valikosta painamalla yhtä aikaa **FLASH-**painiketta sekä molempia **säätönuppeja** ja vapauttamalla sitten ne.



LED-tilan vaihto GT3 tai Formula

- Siirry LED-valikkoon painamalla yhtä aikaa **FLASH-**painiketta sekä molempia **säätönuppeja 5 sekunnin ajan** ja vapauttamalla sitten ne.
- Käännä **oikeaa säätönuppia (MAP)** vasemmalle valitaksesi GT3-tilan (punainen LED) tai oikealle valitaksesi Formula-tilan (sininen LED).



GT3-tila (oletustila)



FORMULA-tila

- Poistu LED-valikosta painamalla yhtä aikaa **FLASH-**painiketta sekä molempia **säätönuppeja** ja vapauttamalla sitten ne.



7. Vaihdevivun mukautus

Ferrari 488 GT3 Wheel Add-Onin vaihdevivun etäisyyttä ja liikettä voi säätää.

Etäisyydessä säädetään vaihdevivun asennon leveyttä, mikä muokkaa ratin kädensijan ja vaihdevivun välistä etäisyyttä.

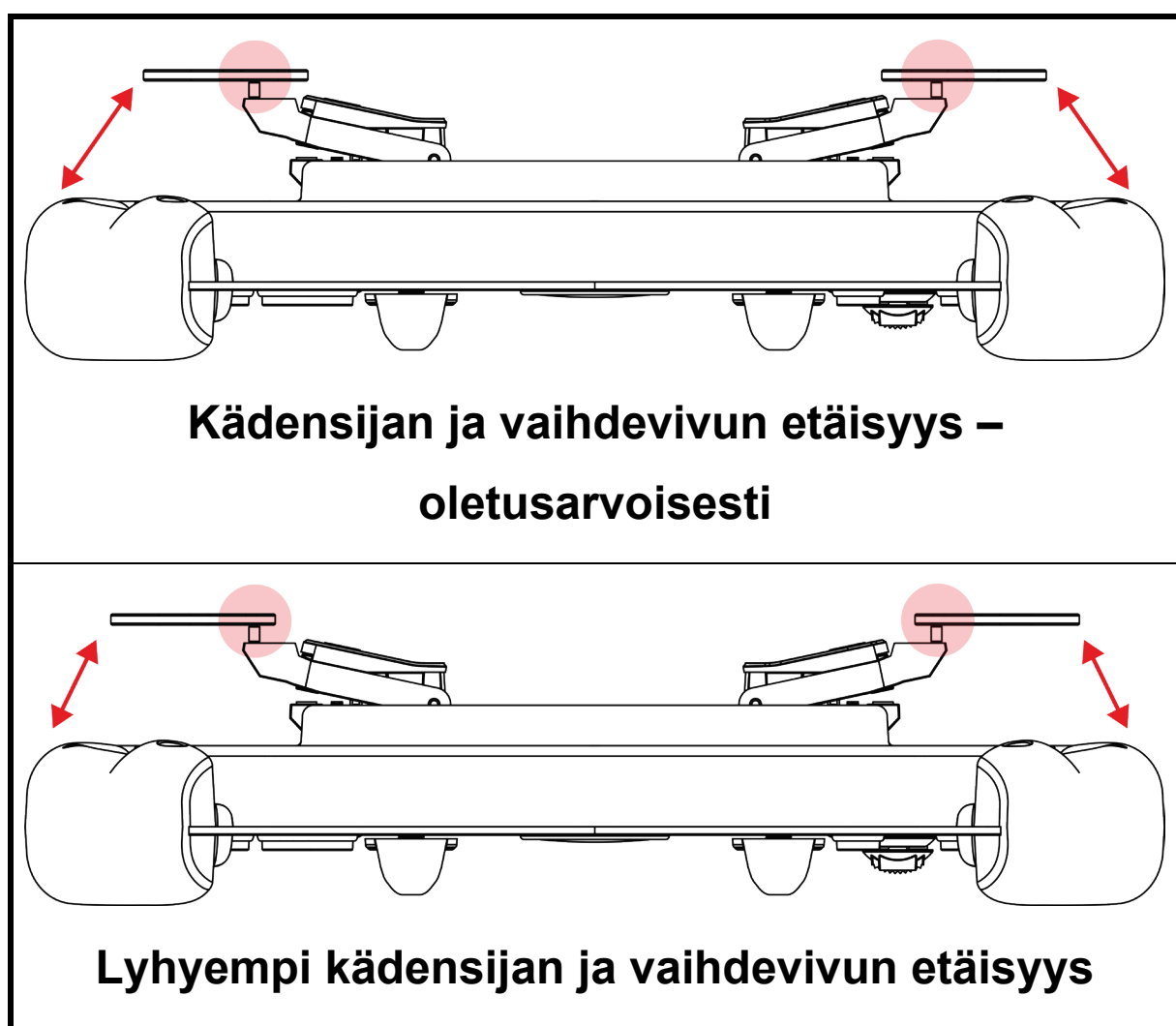



Välikappaleilla voi säätää **liikettä**, mikä muokkaa vaihdevivun aktivointietäisyyttä.

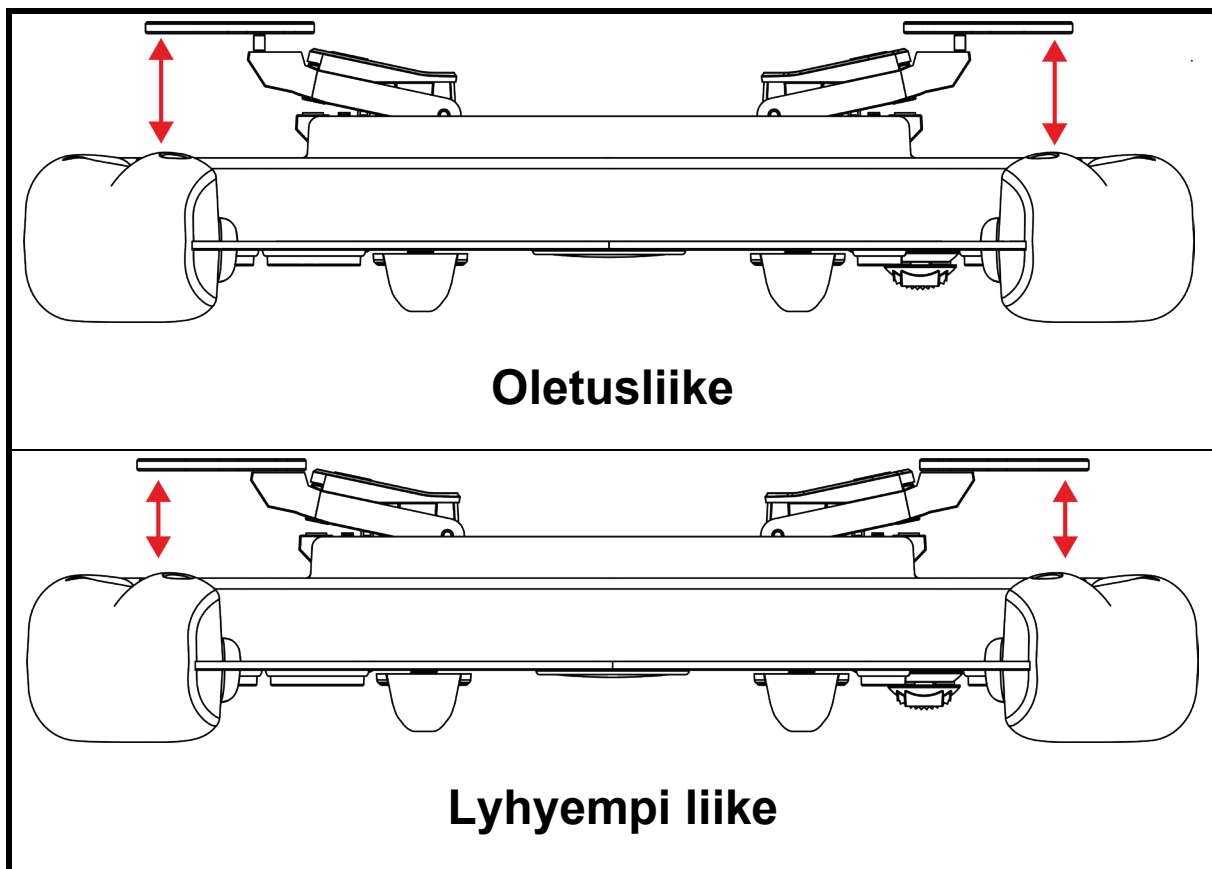

Vaihdevivun **magneettista herkkyyttä** ja **äänentaso** voi myös säätää mukana tulevilla tyynyillä.

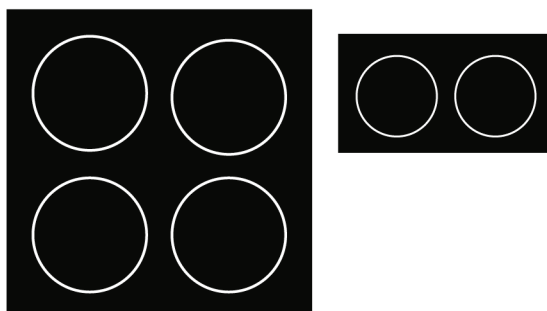



Vaihdevivun etäisyyden säätö

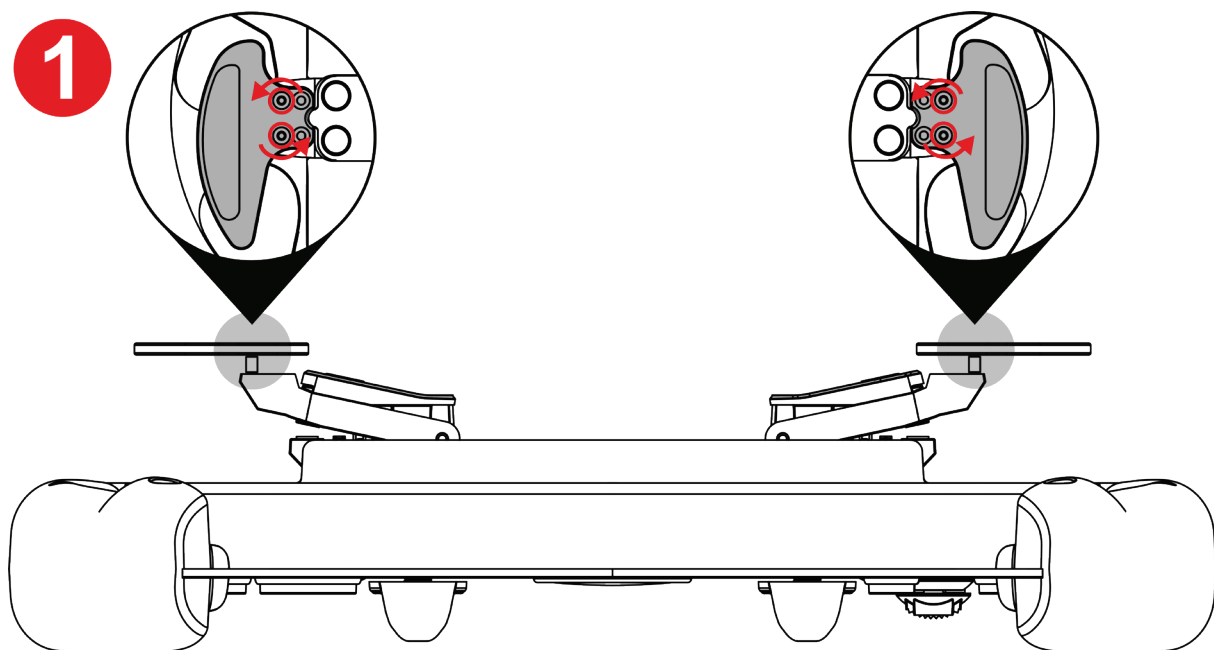

1 Avaa vaihdevivun neljä ruuvia käyttämällä mukana tulevaa Torx-avainta.

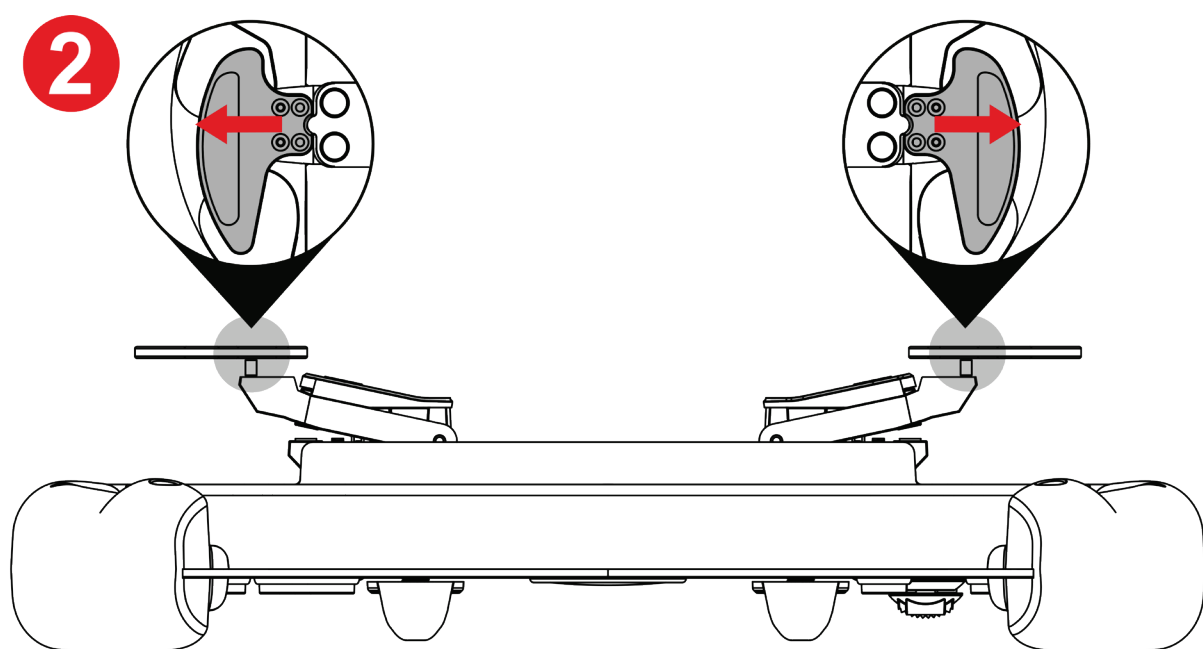

2 Siirrä vaihdevivua ulospäin reikien kohdalle.

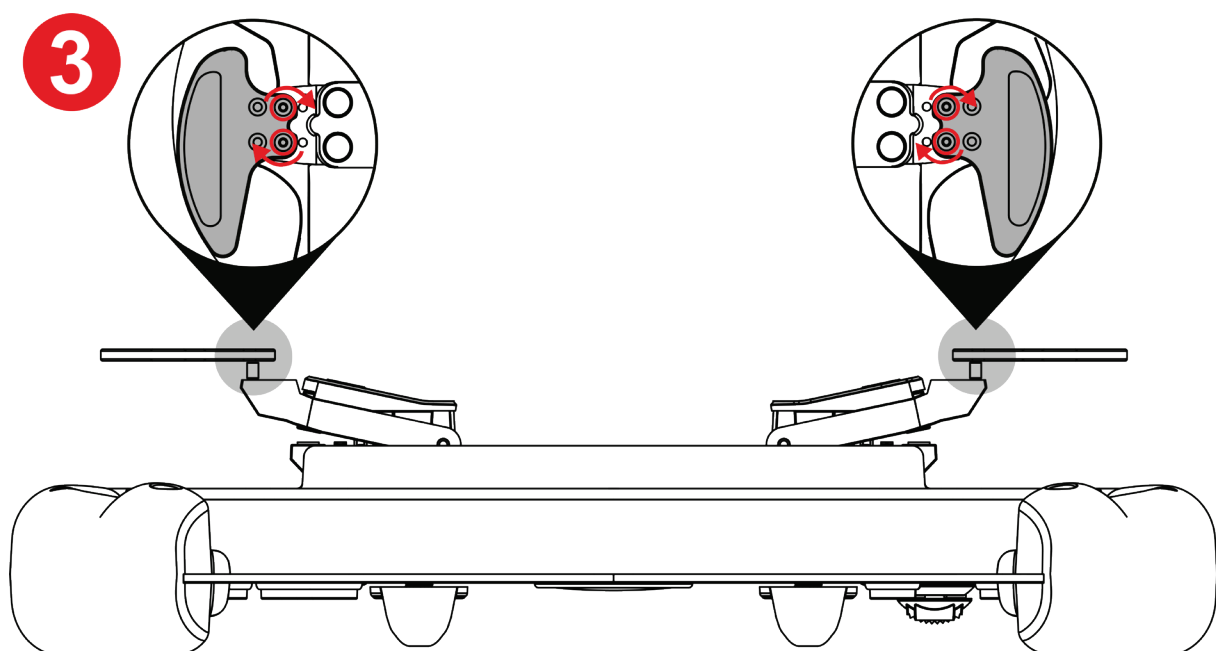

3 Kiristä vaihdevivun neljä ruuvia käyttämällä mukana tulevaa Torx-avainta.



Vaihdevivun liikkeen säätö

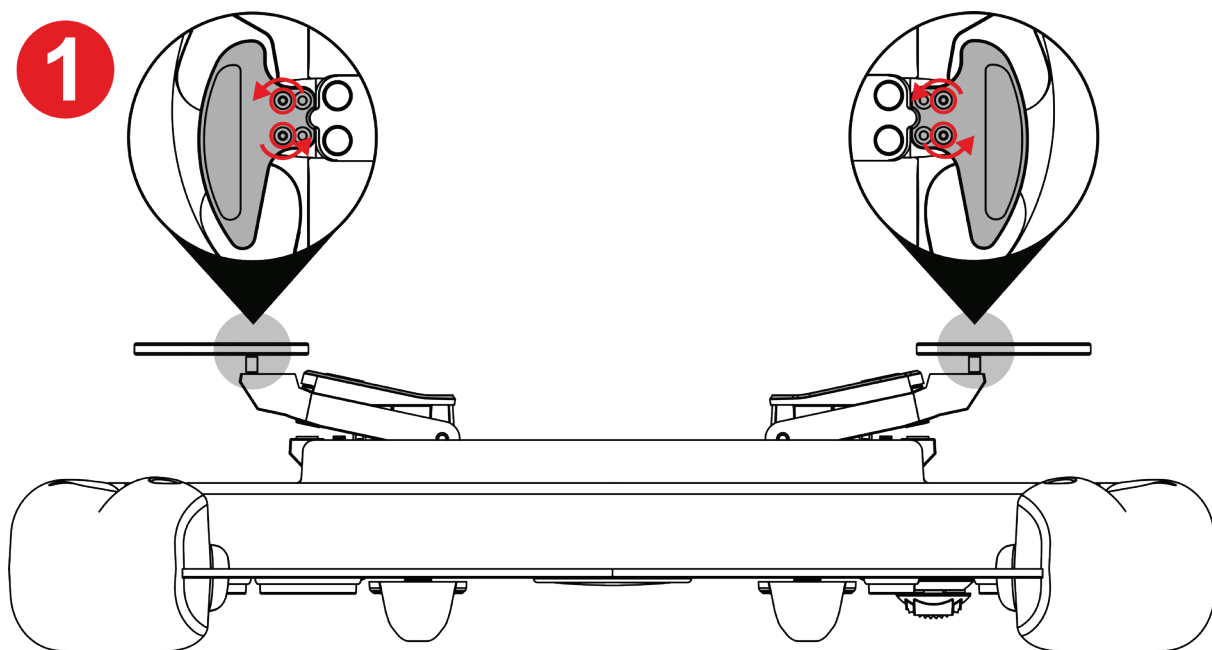

1 Avaa vaihdevivun neljä ruuvia käyttämällä mukana tulevaa Torx-avainta.

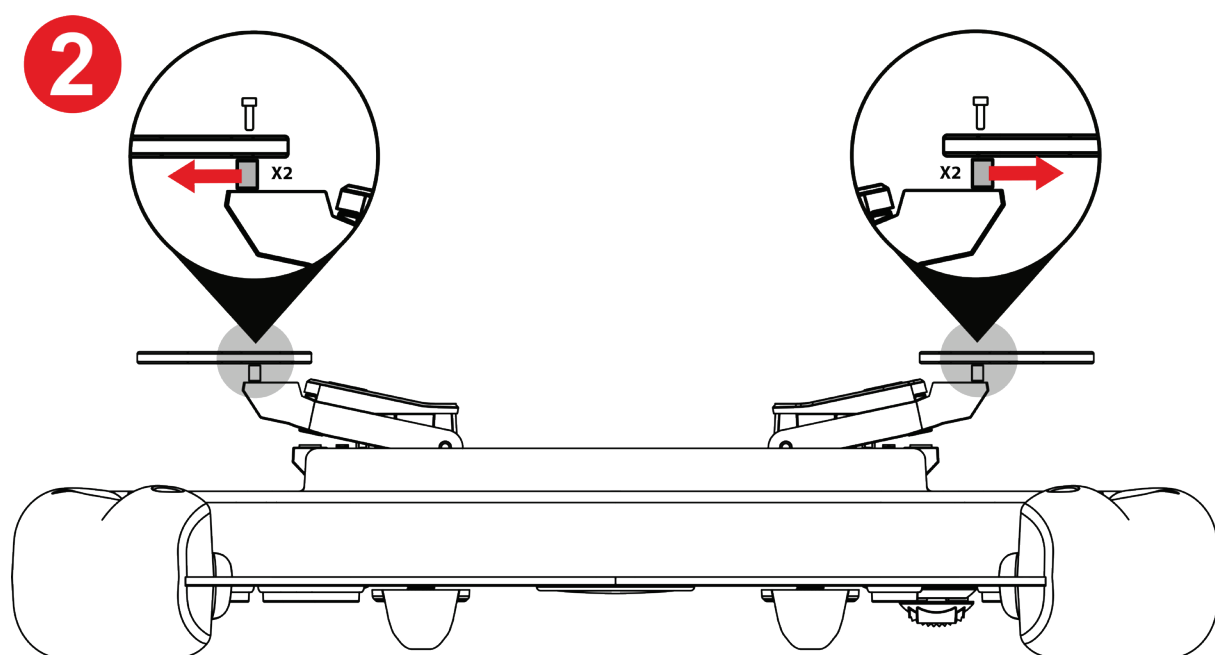

2 Poista välikappaleet.

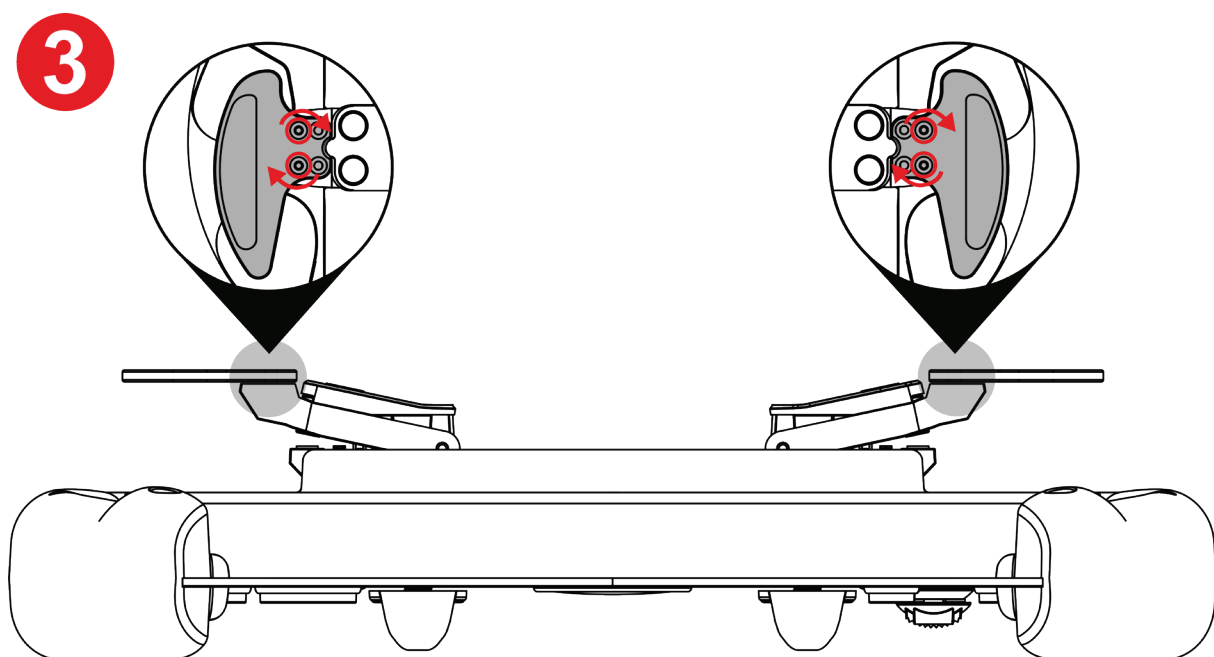

3 Kiristä vaihdevivun neljä ruuvia käyttämällä mukana tulevaa Torx-avainta.



Vaihdevivun magneettisen herkkyyden ja äänentason säätö

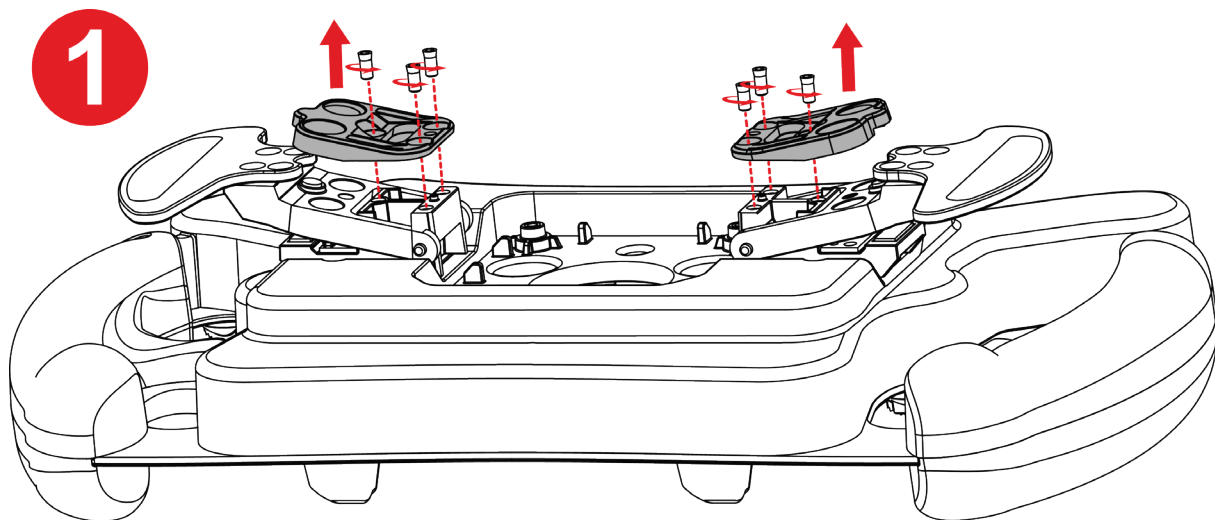

1 Poista magneettiset rajoittimet avaamalla kuusi rajoitinruuvia mukana tulevalla Torx-avaimella.

2

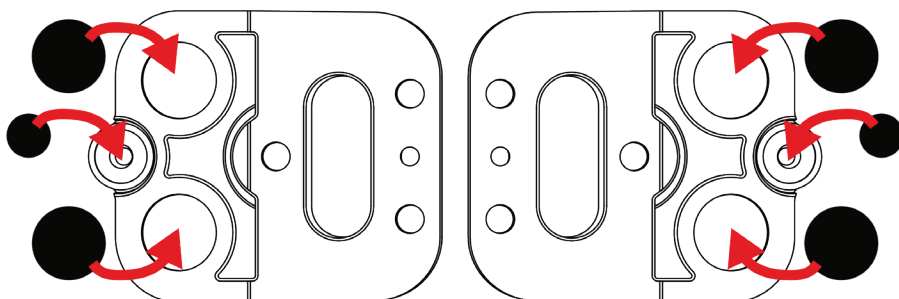
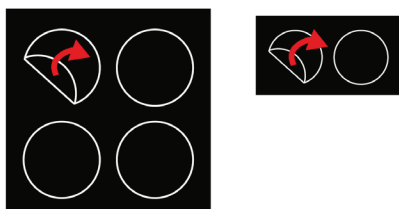

2 Irrota mukana tulevat tyynyt ja kiinnitä ne sopiviin kohtiin magneettisten rajoitinten alle.



Mahdolliset asetukset ja niiden vaikutukset löytyvät **Magneettisen herkkyyden ja vaihdevivun äänten vaimennustaulukosta.**



3

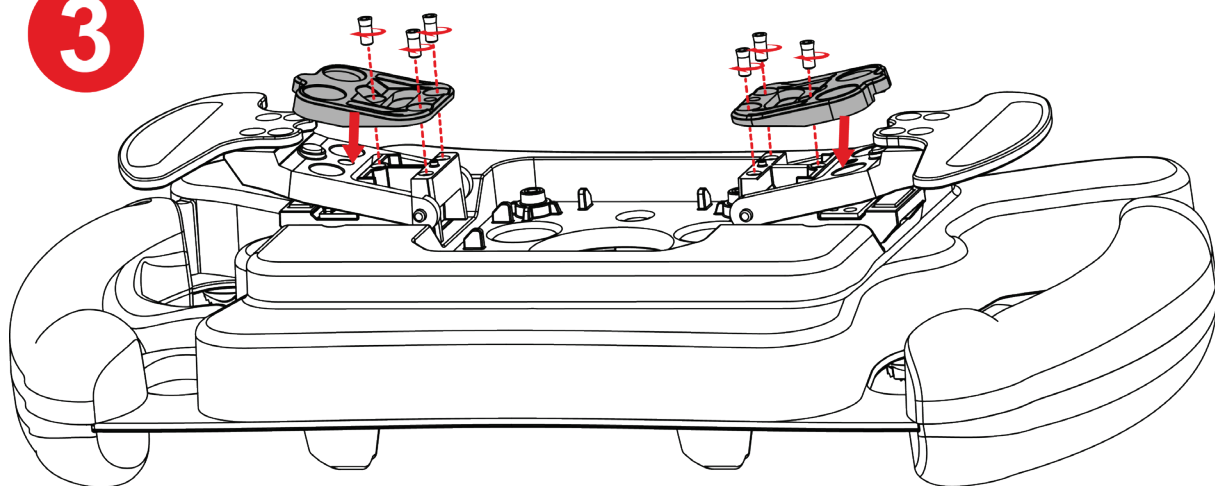

3 Aseta magneettiset rajoittimet takaisin ja kiristä kuusi rajoitinruuvia mukana tulevalla Torx-avaimella.

Magneettisen herkkyyden ja vaihdevivun äänen vaimennustaulukko

	<p>(oletus)</p>		
Magneettinen herkkyys			
Ääni			



8. UKK ja tekninen tuki

Onko sinulla kysymyksiä Ferrari 488 GT3 Wheel Add-On -ratista tai kärsitkö teknisistä ongelmista? Mikäli näin on, vieraile Thrustmasterin teknisen tuen sivustolla:

<https://support.thrustmaster.com/product/ferrarif488gt3addon>.

Tällä sivulla voi myös päivittää ratin laiteohjelmiston.



THRUSTMASTER®

FERRARI 488 GT3 WHEEL ADD-ON

PC (Windows 10/11)

PS4™ / PS5™

Xbox Series / Xbox One

Návod na použitie



Pred inštaláciou produktu, **pred** akýmkoľvek použitím produktu a **pred** akoukoľvek údržbou si **pozorne prečítajte** pokyny uvedené v tomto návode. Bezpodmienečne dodržiavajte bezpečnostné pokyny. Nedodržanie týchto pokynov môže viesť k nehodám a/alebo škodám. Uschovajte si tento návod, aby ste si ho mohli v budúcnosti prečítať.

OBSAH

1.	OBSAH BALENIA	5
2.	VLASTNOSTI.....	6
3.	INFORMÁCIE O POUŽÍVANÍ VOLANTU.....	8
4.	INŠTALÁCIA DRŽIAKA NA RÝCHLE UVOLNENIE	13
	<i>Inštalácia držiaka rýchleho uvoľnenia pre západkovú základňu</i>	<i>14</i>
	<i>Inštalácia držiaka rýchleho uvoľnenia pre skrutkovaciu základňu.....</i>	<i>17</i>
5.	MAPOVANIE.....	21
	<i>Mapovanie pre PC</i>	<i>21</i>
	<i>Mapovanie pre PS4™/PS5™</i>	<i>22</i>
	<i>Mapovanie pre Xbox Series/Xbox One.....</i>	<i>23</i>
6.	LED FUNKCIA	24
	<i>Ako vstúpiť do/opustiť ponuku LED menu</i>	<i>25</i>
	<i>Ako nastaviť intenzitu LED</i>	<i>27</i>

Ako zmeniť režim LED: GT3 alebo

Formula28

7. PRISPÔSOBENIE PÁDIEL RADENIA.....29

Ako nastaviť rozstup pádla radenia31

Ako nastaviť dosah pádla radenia.....33

Ako nastaviť magnetickú citlivosť a

úroveň zvuku pádiel radenia35

8. ČASTO KLADENÉ OTÁZKY A TECHNICKÁ

PODPORA37



FERRARI 488 GT3 WHEEL ADD-ON

Staňte sa súčasťou legendy pretekov GT s Ferrari 488 GT3 Wheel Add-On, volantom navrhnutým pre výkon a kompatibilným so všetkými základňami volantov Thrustmaster.

Tento návod vám pomôže nainštalovať a používať váš Ferrari 488 GT3 Wheel Add-On za tých najlepších podmienok. Skôr ako začnete pretekať, pozorne si prečítajte pokyny a upozornenia: pomôžu vám získať z vášho produktu maximálny pôžitok.



1. Obsah balenia

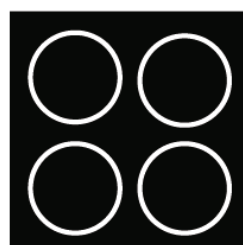
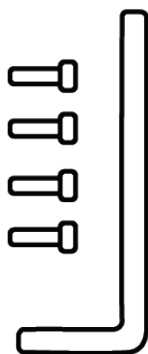
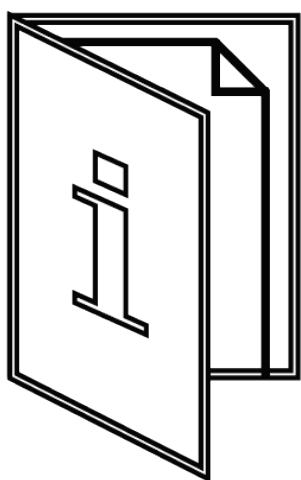
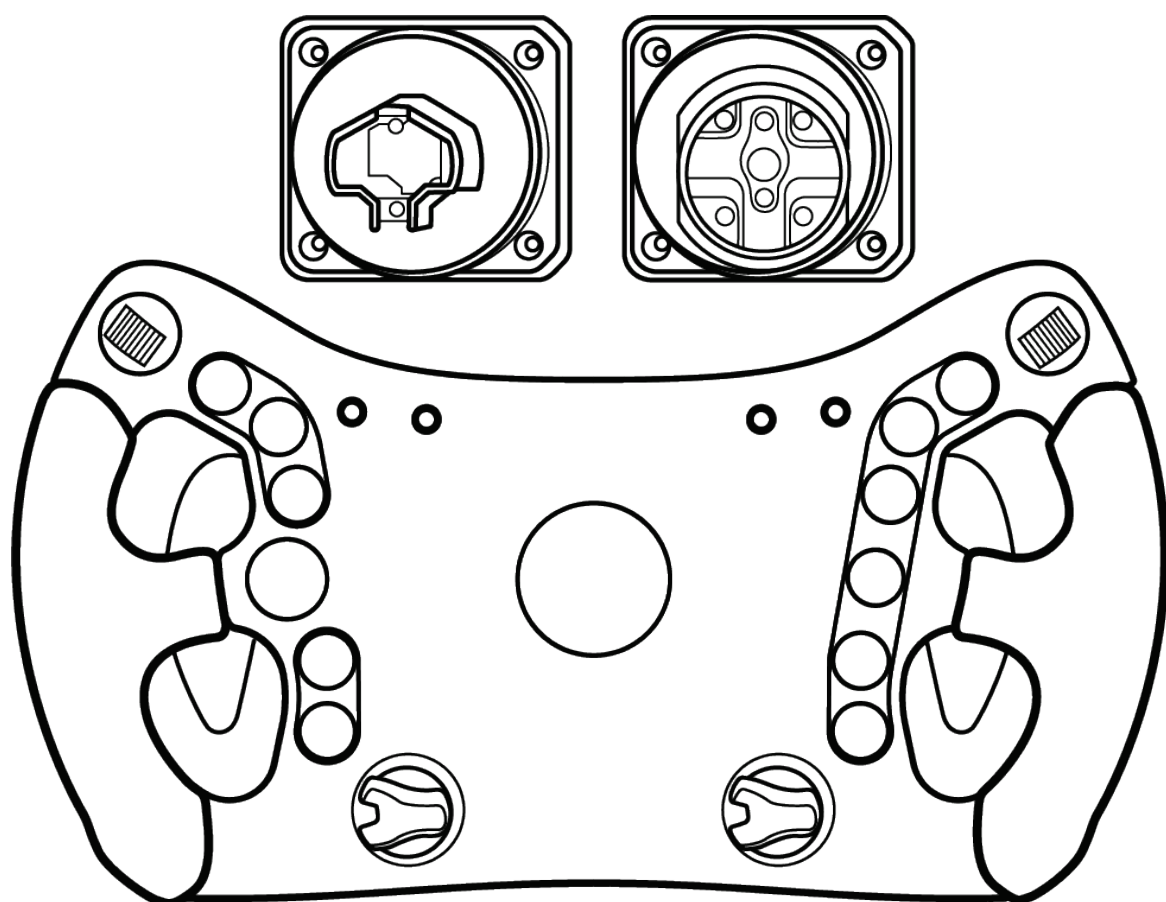



2. Vlastnosti

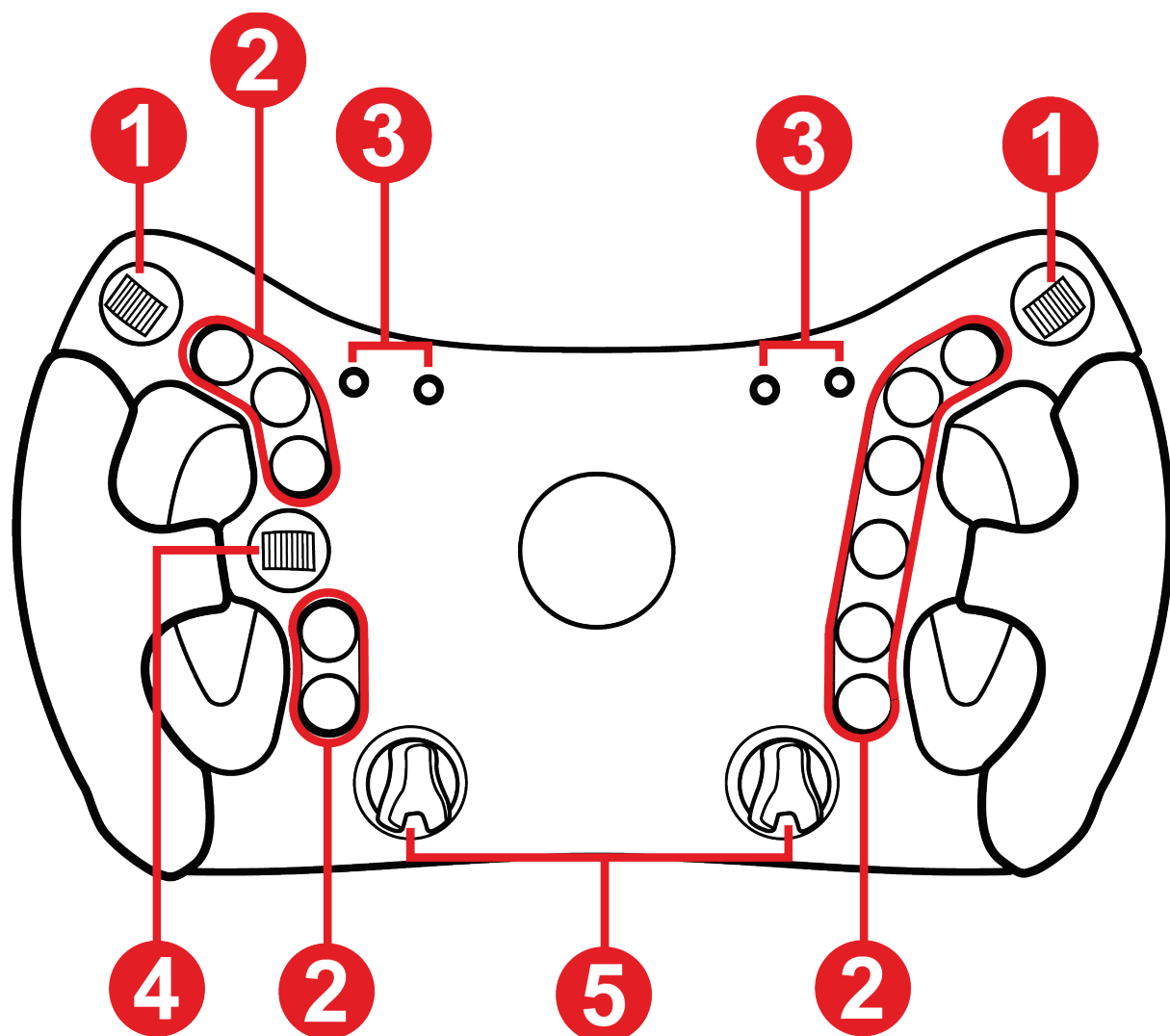

- ❶ **Palcové enkódery**
- ❷ **11 akčných tlačidiel**
- ❸ **RPM LED svetlá a pretekárske dáta (vlajky, boxy)**
- ❹ **D-pad**
- ❺ **Otočné enkódery**

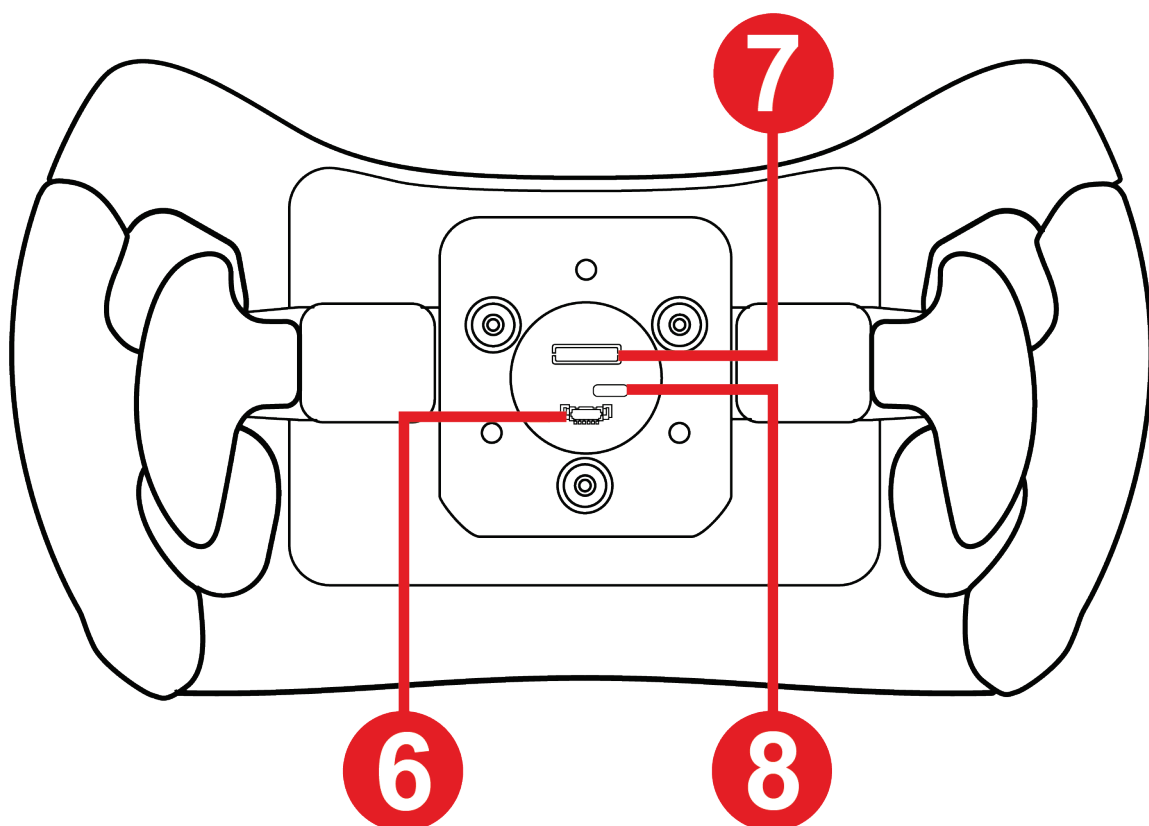

⑥ Pripojovací port pre držiak rýchleho uvoľnenia na skrutkovaciu základňu

⑦ Pripojovací port pre držiak rýchleho uvoľnenia na západkovú základňu

⑧ USB-C port (ak je potrebná aktualizácia firmvéru – kábel nie je súčasťou balenia)

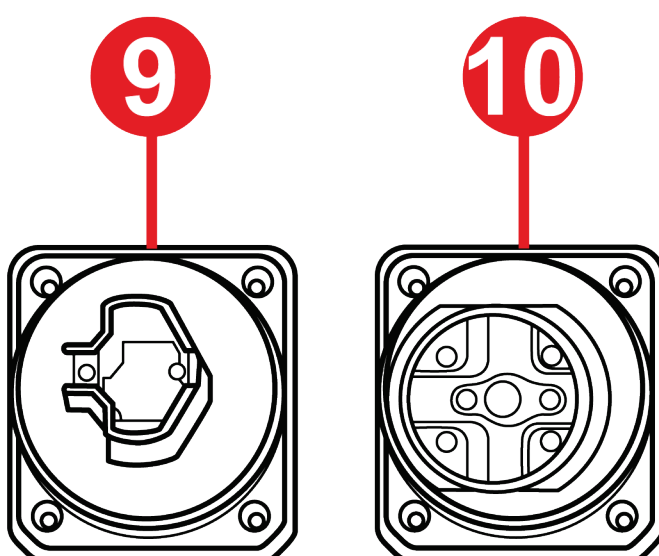

⑨ Držiak rýchleho uvoľnenia na západkovú základňu

⑩ Držiak rýchleho uvoľnenia na skrutkovaciu základňu



3. Informácie o používaní volantu



Dokumentácia

Pred použitím tohto produktu si ešte raz pozorne prečítajte túto dokumentáciu a uschovajte si ju pre budúce použitie.



Úraz elektrickým prúdom

- Výrobok uchovávajte na suchom mieste a nevystavujte ho prachu ani slnečnému žiareniu.
- Neskrúcajte ani neťahajte za konektory a káble.
- Postupujte podľa pokynov na pripojenie.
- Na produkt ani jeho konektory nevyliievajte žiadnu tekutinu.
- Neskratujte výrobok.
- Nikdy nerozoberajte výrobok (okrem prípadov prispôsobenia špecifikovaných v tomto návode); nehádzte ho do ohňa a nevystavujte ho vysokým teplotám.
- Neotvárajte zariadenie: vnútri nie sú žiadne časti, ktoré by mohol opraviť používateľ. Akékoľvek opravy musí vykonať výrobca, určená agentúra alebo kvalifikovaný technik.



Zabezpečenie herného priestoru

- Do herného priestoru neumiestňujte žiadne predmety, ktoré by mohli narúšať výkon užívateľa, alebo ktoré môžu vyvolať nevhodný pohyb alebo prerušenie inou osobou (napr. šálka kávy, telefón, kľúče).
- Napájacie káble nezakrývajte kobercom, prikrývkou, tkaninou ani iným predmetom a žiadne káble neumiestňujte tam, kde budú ľudia chodiť.



Zranenia v dôsledku Force Feedback a opakovaných pohybov

Používanie pretekárskeho volantu s Force Feedback môže spôsobiť bolesť svalov alebo kĺbov. Ak sa chcete vyhnúť problému:

- Predtým sa zahrejte a vyhnite sa zdĺhavému tréningu.
- Po každej hodine cvičenia si urobte 10 až 15-minútovú prestávku.
- Ak pociťujete akúkoľvek únavu alebo bolesť v rukách, zápästiach, pažiach, chodidlách alebo nohách, stlačením tlačidla vypnite Force Feedback, vypnite základňu a niekoľko hodín si oddýchnite, kým znova začnete cvičiť.
- Ak príznaky alebo bolesti uvedené vyššie pretrvávajú, keď znovu začnete cvičiť, prestaňte cvičiť a poraďte sa so svojím lekárom.
- Nenastavujte Force Feedback na úroveň, ktorá je príliš vysoká vo vzťahu k vašej odbornosti a vašej fyzickej kondícii.
- Zariadenie uchovávajte mimo dosahu osôb mladších ako 16 rokov.
- Uistite sa, že základňa a volant sú správne pripevnené podľa pokynov v príručke.



Riziko nepredvídaných, silných a rýchlych rotácií: nikdy nekladajte dlaň alebo ruku do otvorov vo volante alebo do trajektórie rotácie volantu.

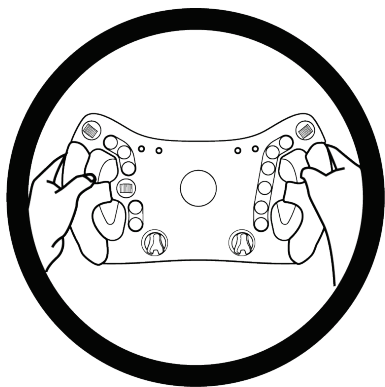

Pri používaní výrobku vždy ponechajte obe ruky správne položené na volante bez toho, aby ste ich úplne pustili.



S výrobkom môžu manipulovať iba osoby **staršie ako 16 rokov**.



4. Inštalácia držiaka na rýchle uvoľnenie

Ferrari 488 GT3 Wheel Add-On sa dodáva s dvoma držiakmi rýchleho uvoľnenia zodpovedajúcimi formátom základní Thrustmaster.

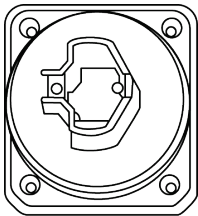
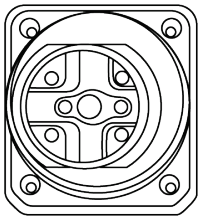
Systém	Kompatibilita
 <p data-bbox="93 1148 650 1284">Držiak rýchleho uvoľnenia pre západkovú základňu</p>	<p data-bbox="677 966 1282 1181">T818, T818 Ferrari SF1000 Simulator a budúce základne Thrustmaster.</p>
 <p data-bbox="93 1558 650 1694">Držiak rýchleho uvoľnenia pre skrutkovaciu základňu</p>	<p data-bbox="677 1319 1282 1694">T-GT / T-GT II Servo Base, T300 RS Servo Base, TS PC Racer, TS-XW, TX Racing Wheel Servo Base, TS-XW Servo Base.</p>



Pred každým použitím skontrolujte, či je **Ferrari 488 GT3 Wheel Add-On** stále správne pripevnený k podpere podľa pokynov v príručke pre základňu.



Inštalácia držiaka rýchleho uvoľnenia pre západkovú základňu

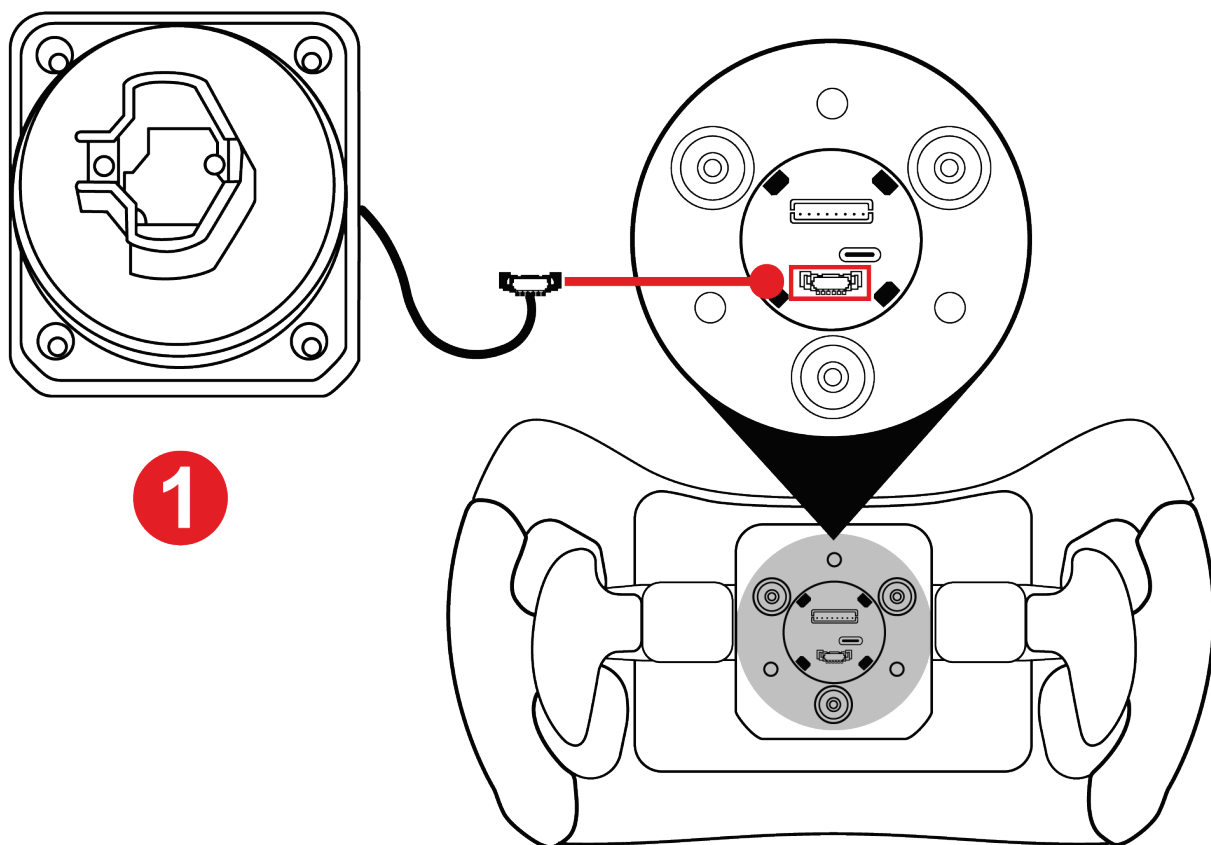

1 Zapojte konektor držiaka rýchleho uvoľnenia do príslušného portu na zadnej strane volantu.



Aby ste predišli pricviknutiu kábla, pred priskrutkovaním držiaka ho zatiahnite do jeho puzdra.

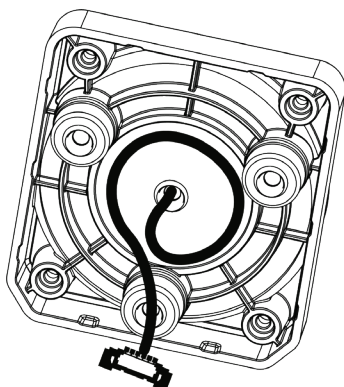

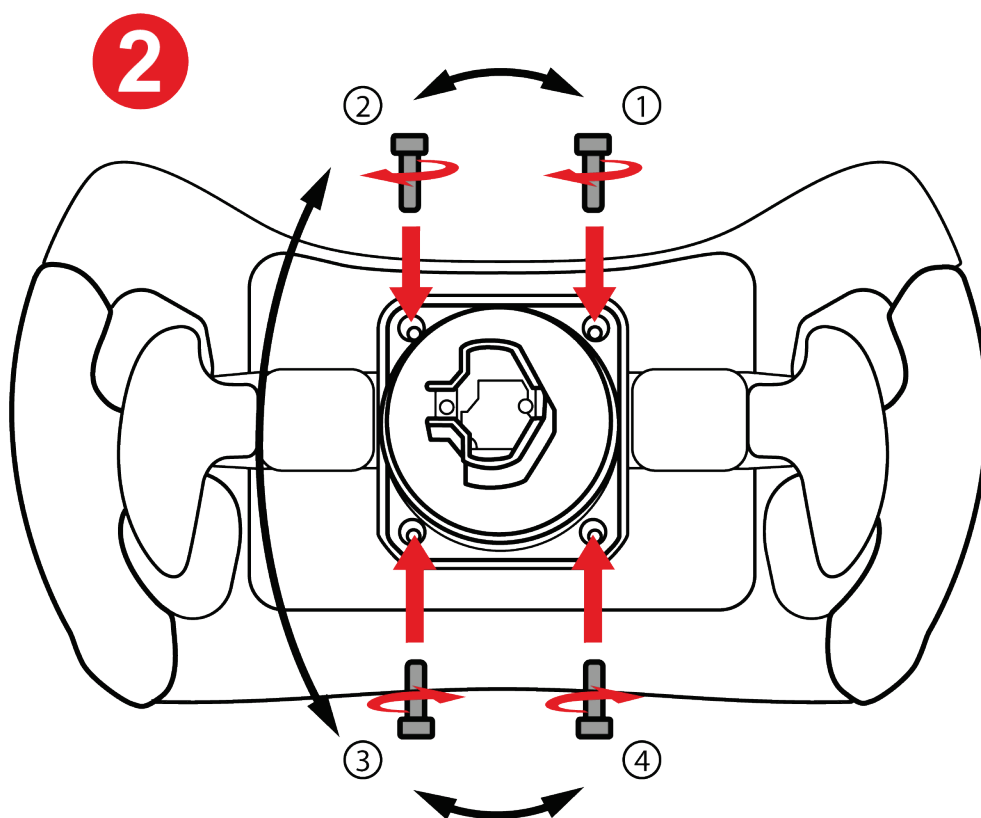

2 Vložte držiak rýchleho uvoľnenia a utiahnite ho pomocou dodaného kľúča Torx.



Pri montáži držiaka skrutky príliš neťahajte.

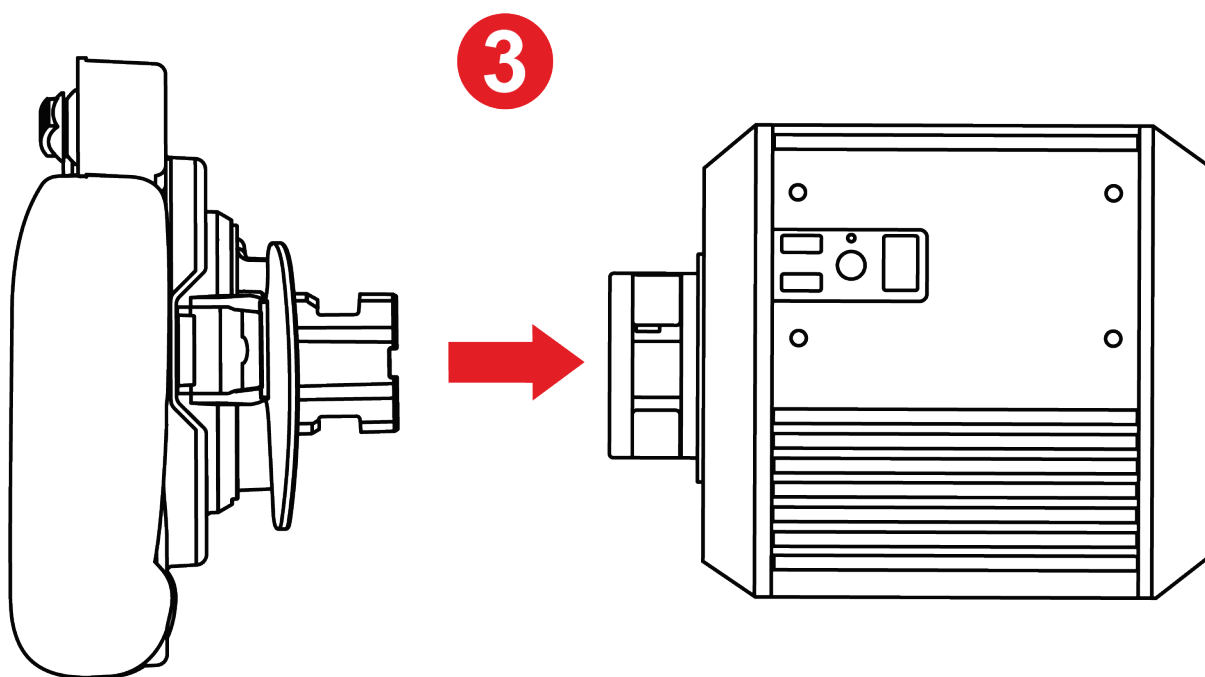

3 Namontujte volant na základňu.



Postupujte podľa inštalačného postupu uvedeného v používateľskej príručke základne.



Inštalácia držiaka rýchleho uvoľnenia pre skrutkovaciu základňu

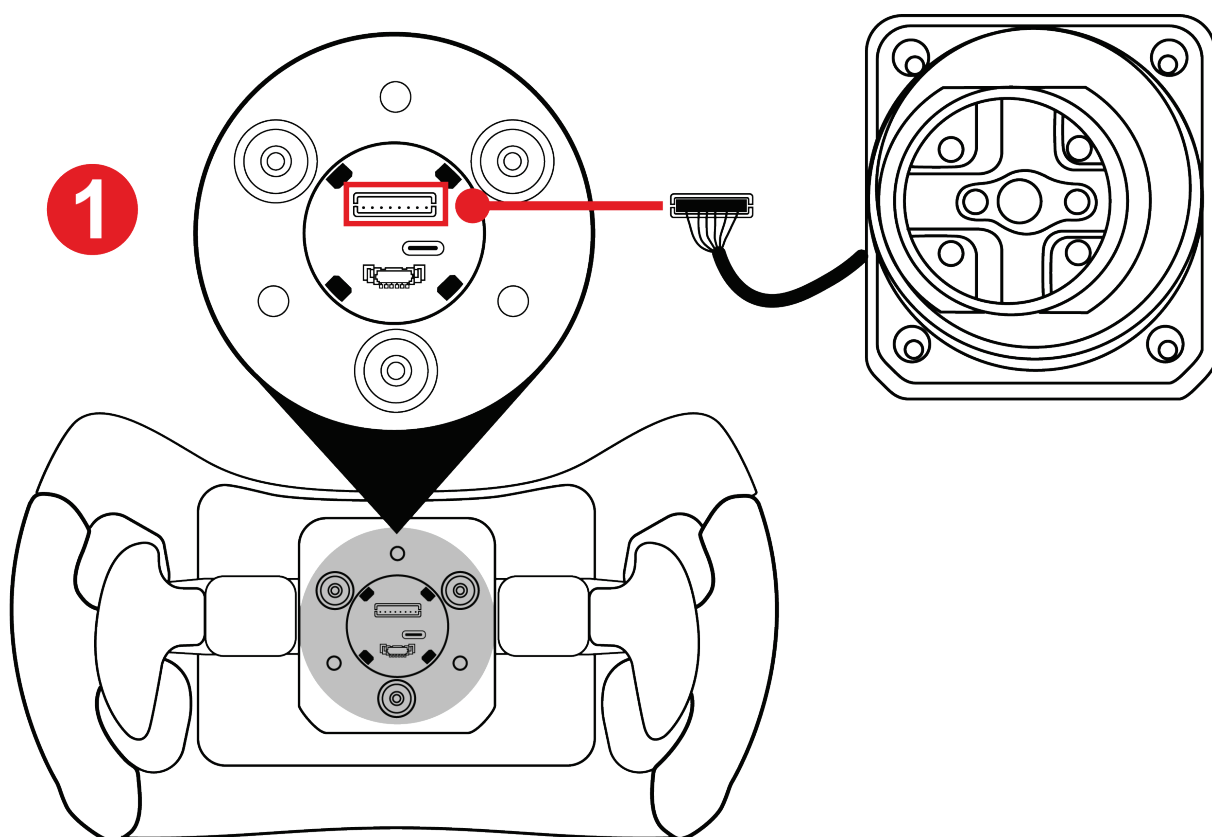

1 Zapojte konektor držiaka rýchleho uvoľnenia do príslušného portu na zadnej strane volantu.



Aby ste predišli pricviknutiu kábla, pred priskrutkovaním držiaka ho zatahnite do jeho puzdra.

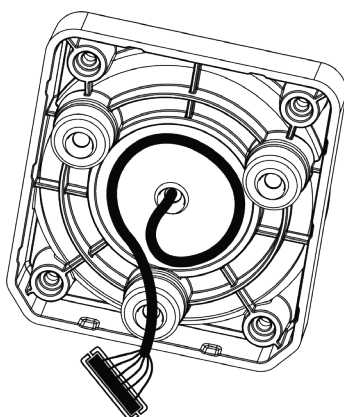

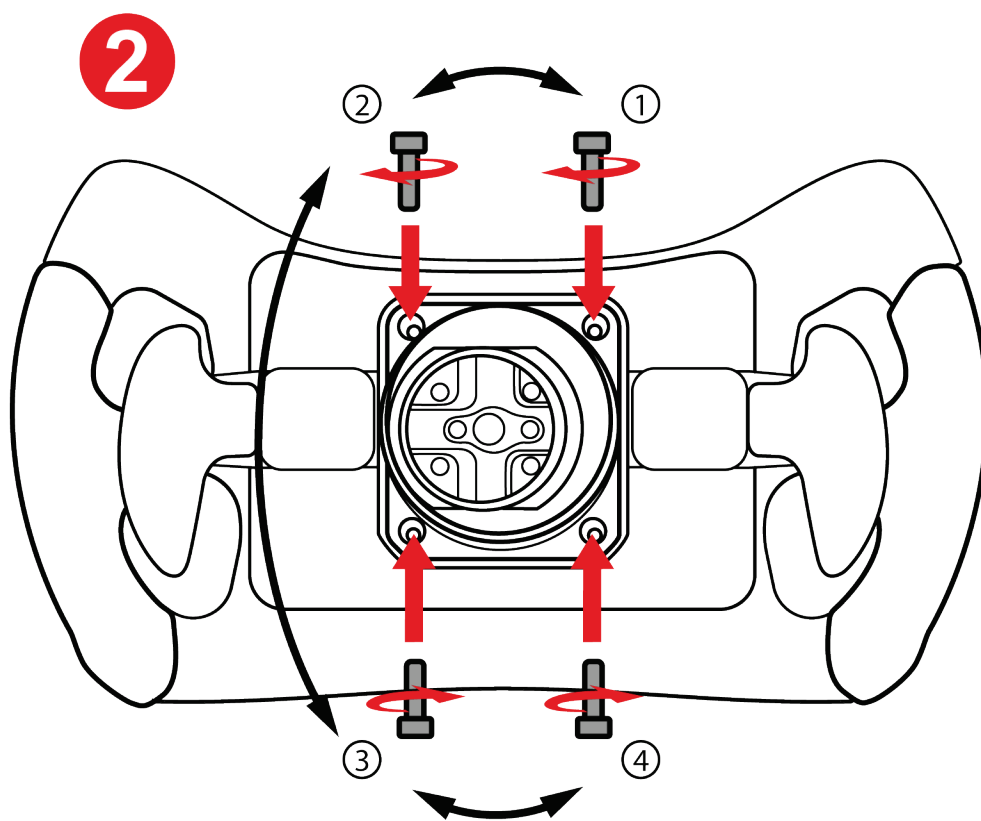

2 Vložte držiak rýchleho uvoľnenia a utiahnite ho pomocou dodaného kľúča Torx.



Pri montáži držiaka skrutky príliš neťahajte.

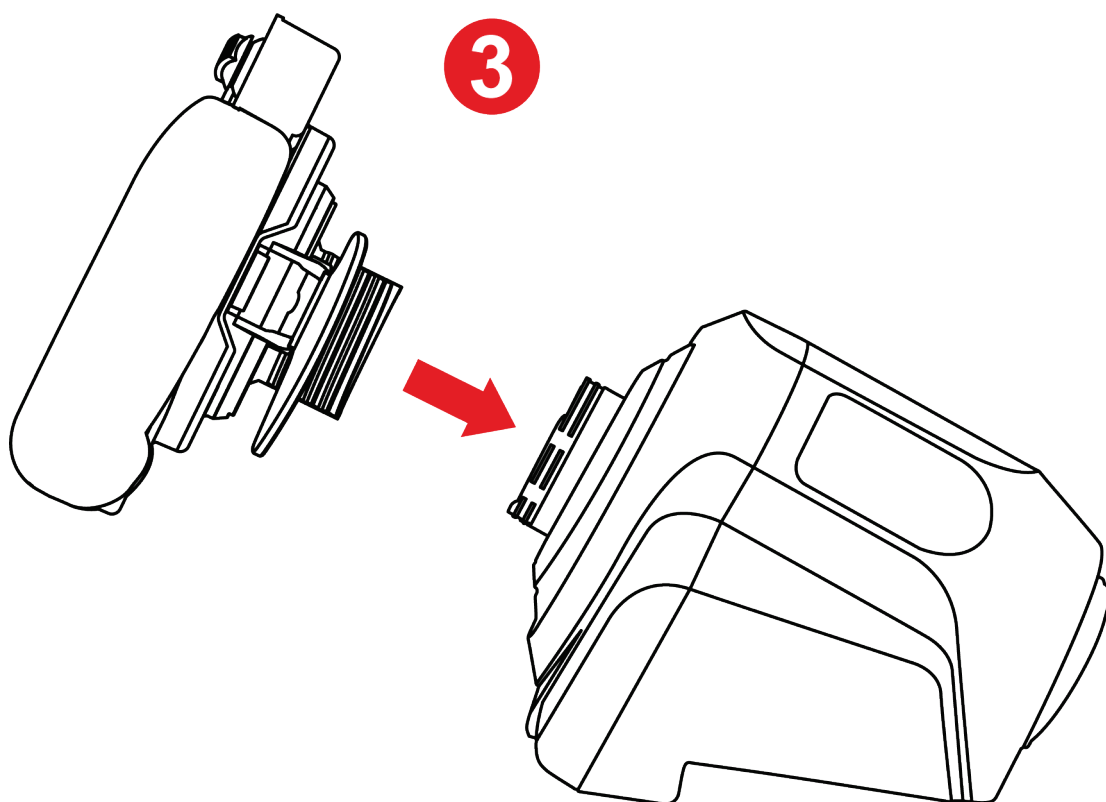

3 Namontujte volant na základňu.



Postupujte podľa inšalačného postupu uvedeného v používateľskej príručke základne.



Nikdy nepripájajte Quick Release Adaptér (dodávaný so základňou T818 a predáva sa samostatne) ku držiaku rýchleho uvoľnenia pre skrutkovaciu základňu, ak ho plánujete použiť na základni T818.

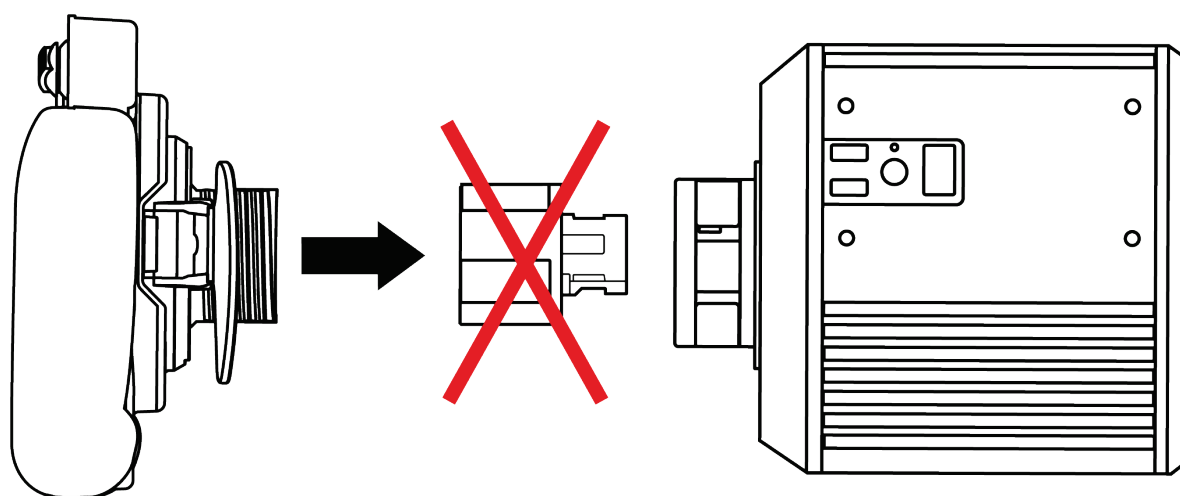
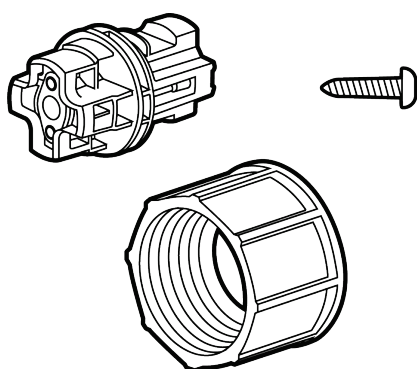

Ak chcete použiť základňu T818 alebo základňu vybavenú konektorom pre západkovú základňu, použite **držiak rýchleho uvoľnenia pre západkovú základňu** dodávanú s **Ferrari 488 GT3 Wheel Add-On**.



5. Mapovanie

Mapovanie pre PC

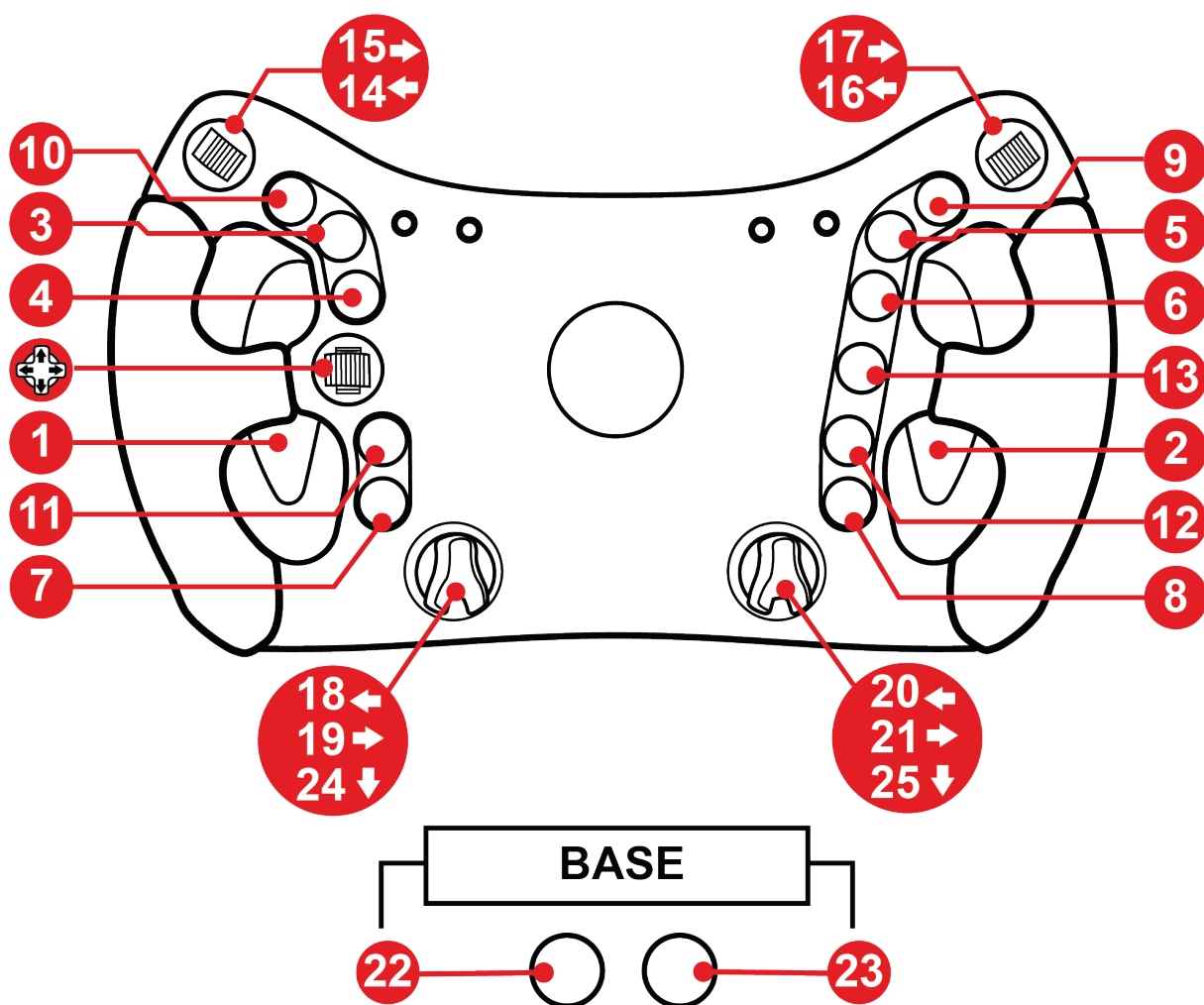



Mapovanie pre PS4™/PS5™

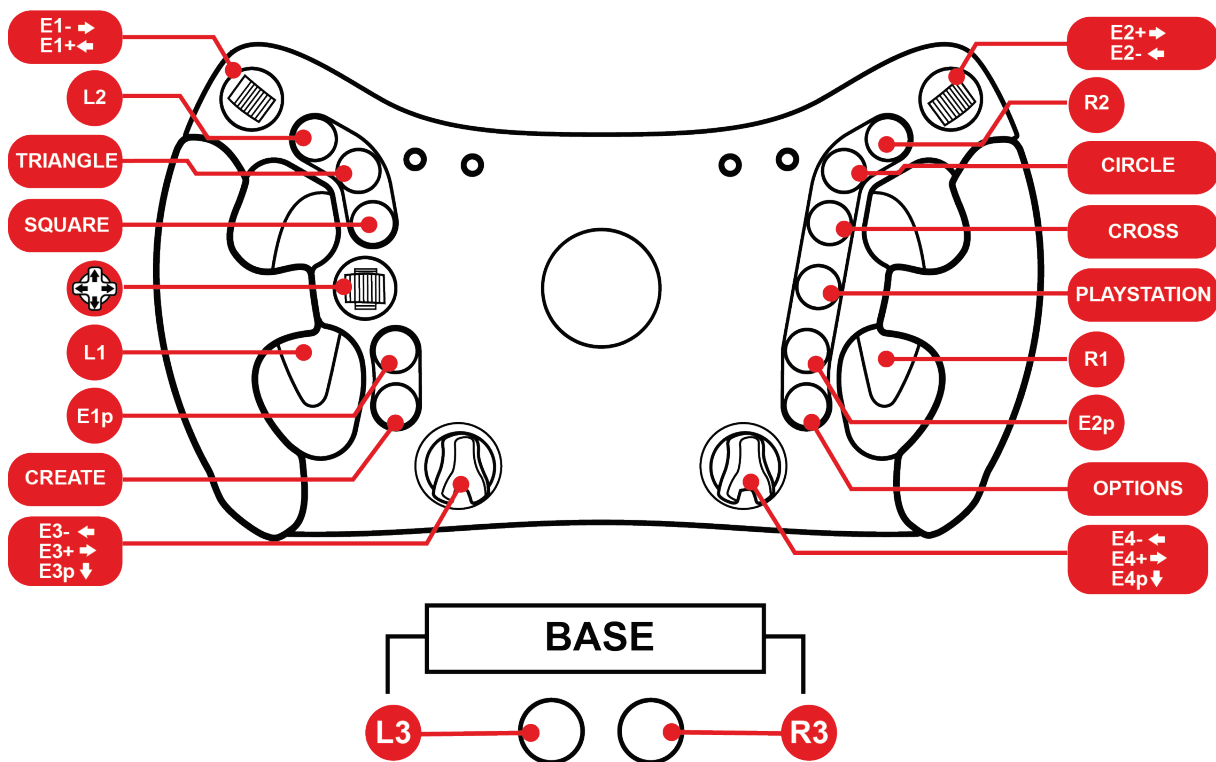



Mapovanie pre Xbox Series/Xbox One

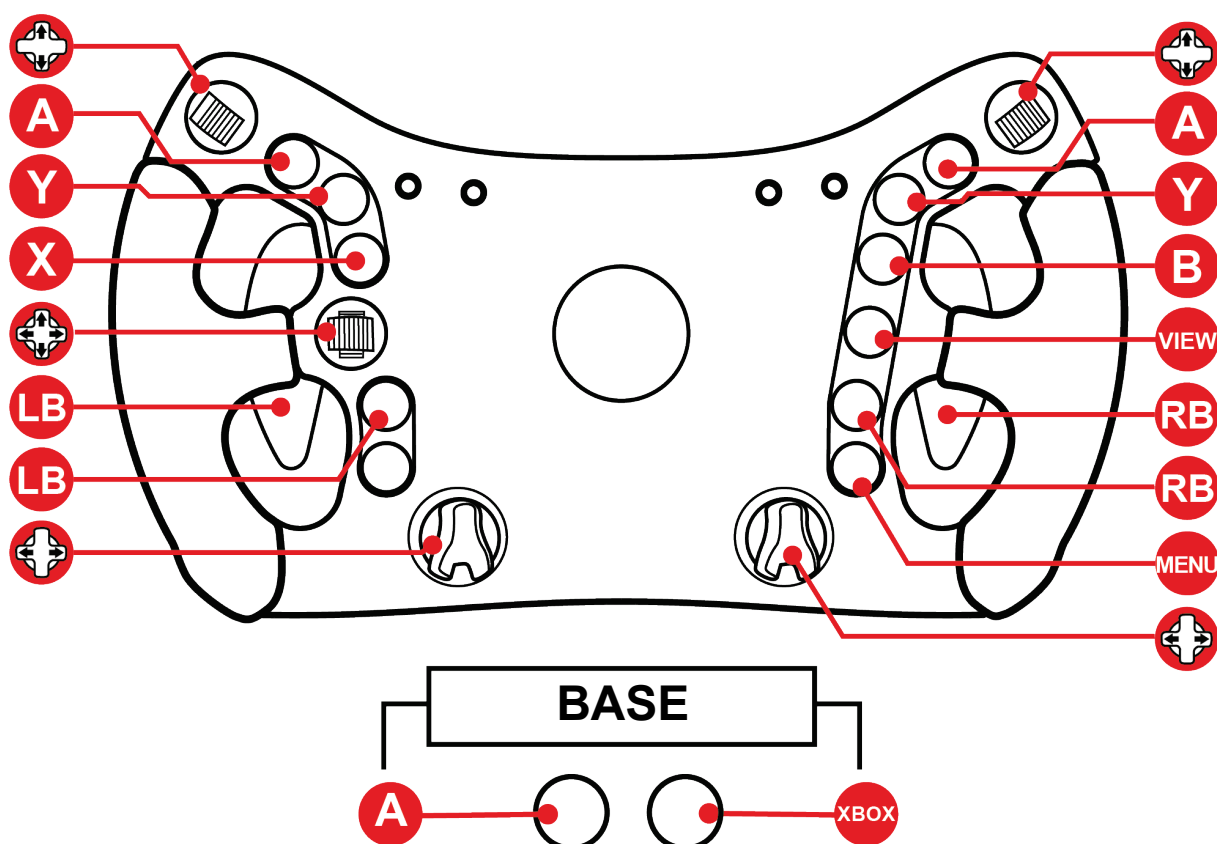

Na Xbox Series a Xbox One:

- LED diódy na Ferrari 488 GT3 Wheel Add-On nie sú funkčné kvôli obmedzeniam protokolu konzoly.
- Niektoré funkcie (enkodéry, počet tlačidiel) sú obmedzené protokolom konzoly.



6. LED funkcia

Ferrari 488 GT3 Wheel Add-On zobrazuje údaje o pretekoch prostredníctvom LED diód: vlajky, boxy a otáčky.

Zobrazené údaje je možné prispôbiť (intenzitu a farbu LED diód RPM) v závislosti od režimu (GT3 alebo Formula).

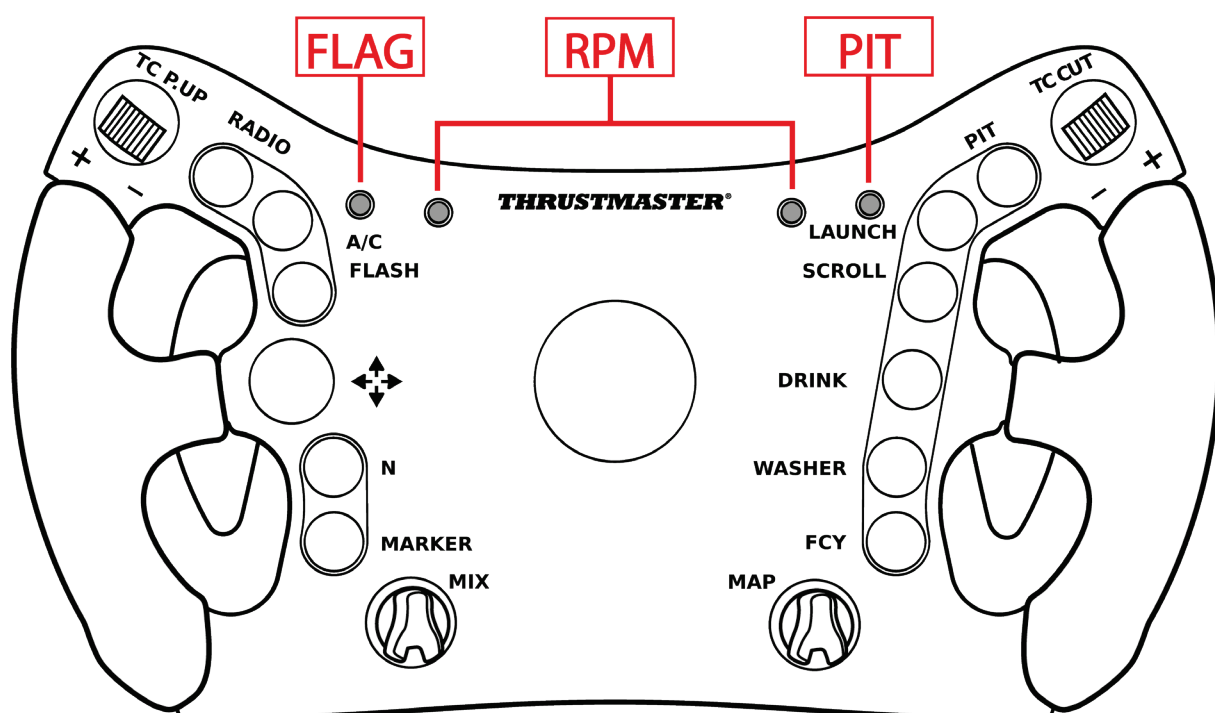

LED diódy sú funkčné na PC a PS4™/PS5™.

Na zariadeniach Xbox Series a Xbox One LED diódy nefungujú z dôvodu obmedzení protokolu konzoly.



Ako vstúpiť do/opustiť ponuku LED menu

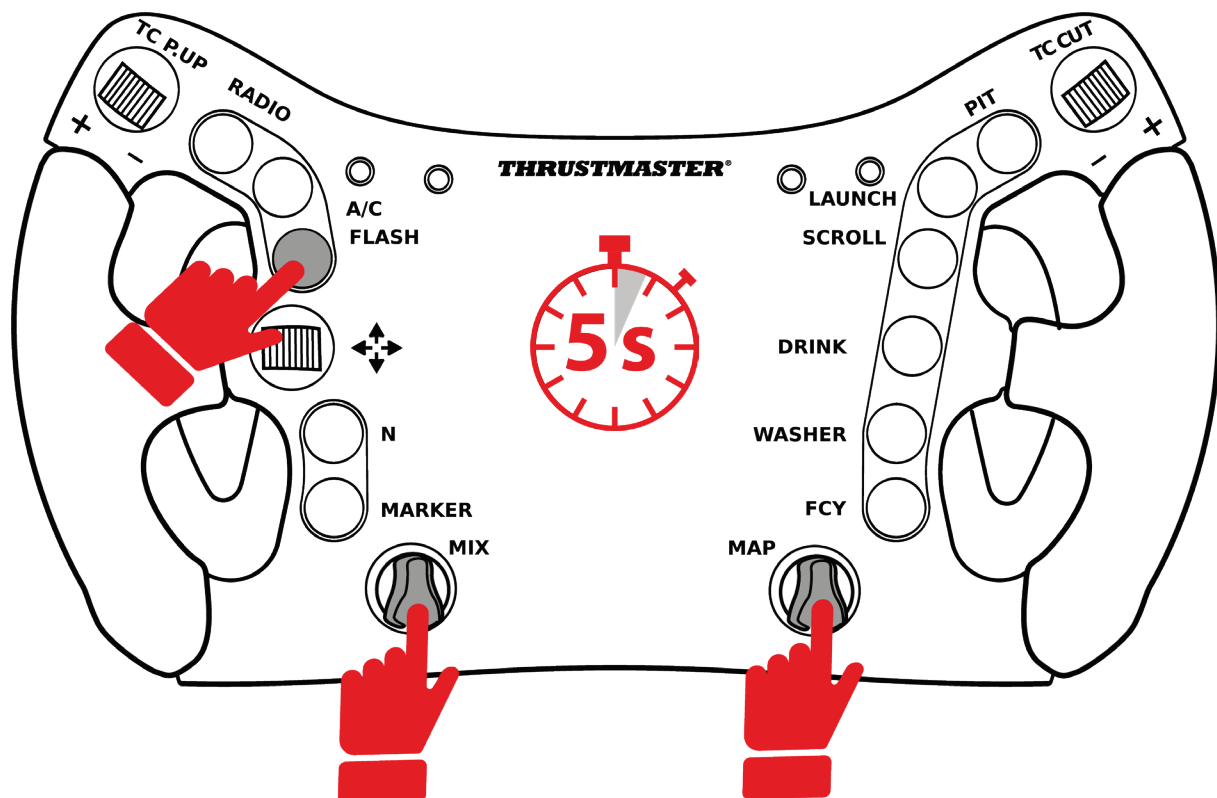

- Pre vstup do LED menu súčasne stlačte tlačidlo **FLASH** a oba **otočné enkóbery na 5 sekúnd**, potom ich uvoľnite.
- Ak chcete opustiť LED menu, súčasne stlačte tlačidlo **FLASH** a oba **otočné enkóbery** a potom ich uvoľnite.



FLAG

RPM

PIT

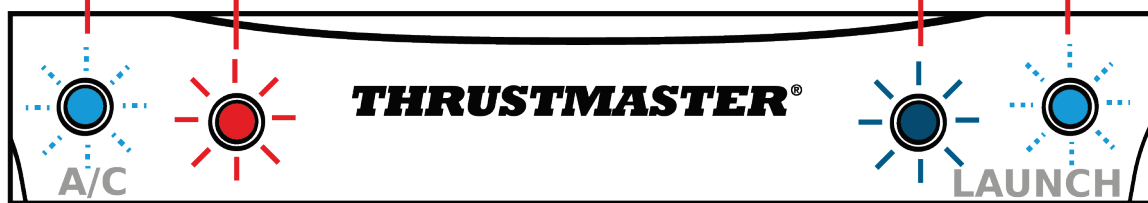

Vstúpte do LED menu: rozsvietia sa LED diódy FLAG a PIT a jedna z LED diód RPM (červená vľavo alebo modrá vpravo).



Opustite LED menu: všetky štyri LED zhasnú.



Ako nastaviť intenzitu LED

Vstúpte do LED menu súčasným stlačením tlačidla **FLASH** a oboch **otočných enkóderov** na 5 sekúnd, potom ich uvoľnite.

- Otočením **ľavého enkodéra (MIX)** doľava intenzitu znížite, otočením doprava intenzitu zvýšite.



- Opustite LED menu súčasným stlačením tlačidla **FLASH** a oboch **otočných enkóderov**, potom ich uvoľnite.



Ako zmeniť režim LED: GT3 alebo Formula

- Vstúpte do LED menu súčasným stlačením tlačidla **FLASH** a oboch **otočných enkóderov** na **5 sekúnd**, potom ich uvoľnite.
- Otočením **pravého enkodéra (MAP)** doľava vyberte režim GT3 (červená LED) alebo doprava a vyberte režim Formula (modrá LED).



GT3 režim (prednastavený režim)



Režim FORMULA

- Opustíte LED menu súčasným stlačením tlačidla **FLASH** a oboch **otočných enkóderov**, potom ich uvoľnite.



7. Prispôsobenie pádiel radenia

Páidla radenia **Ferrari 488 GT3 Wheel Add-On** sú nastaviteľné v **rozostupe** a **dosahu**.

Rozostup spočíva v nastavení šírky páidla radenia, čím sa modifikuje vzdialenosť medzi rukoväťou a pádlom radenia.

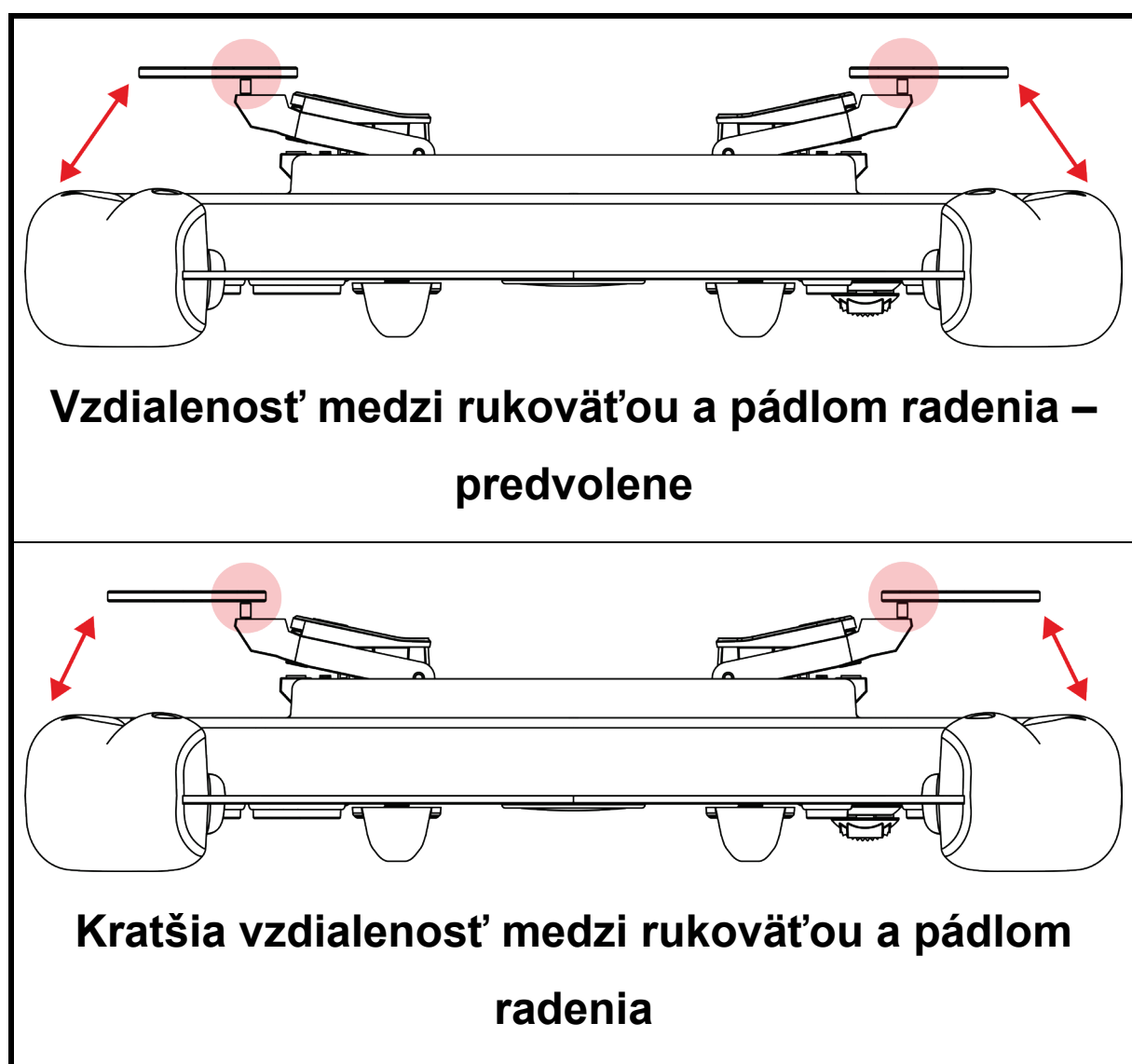



Úpravou **dosahu** pomocou dištančných podložiek sa mení vzdialenosť aktivácie pádla radenia.

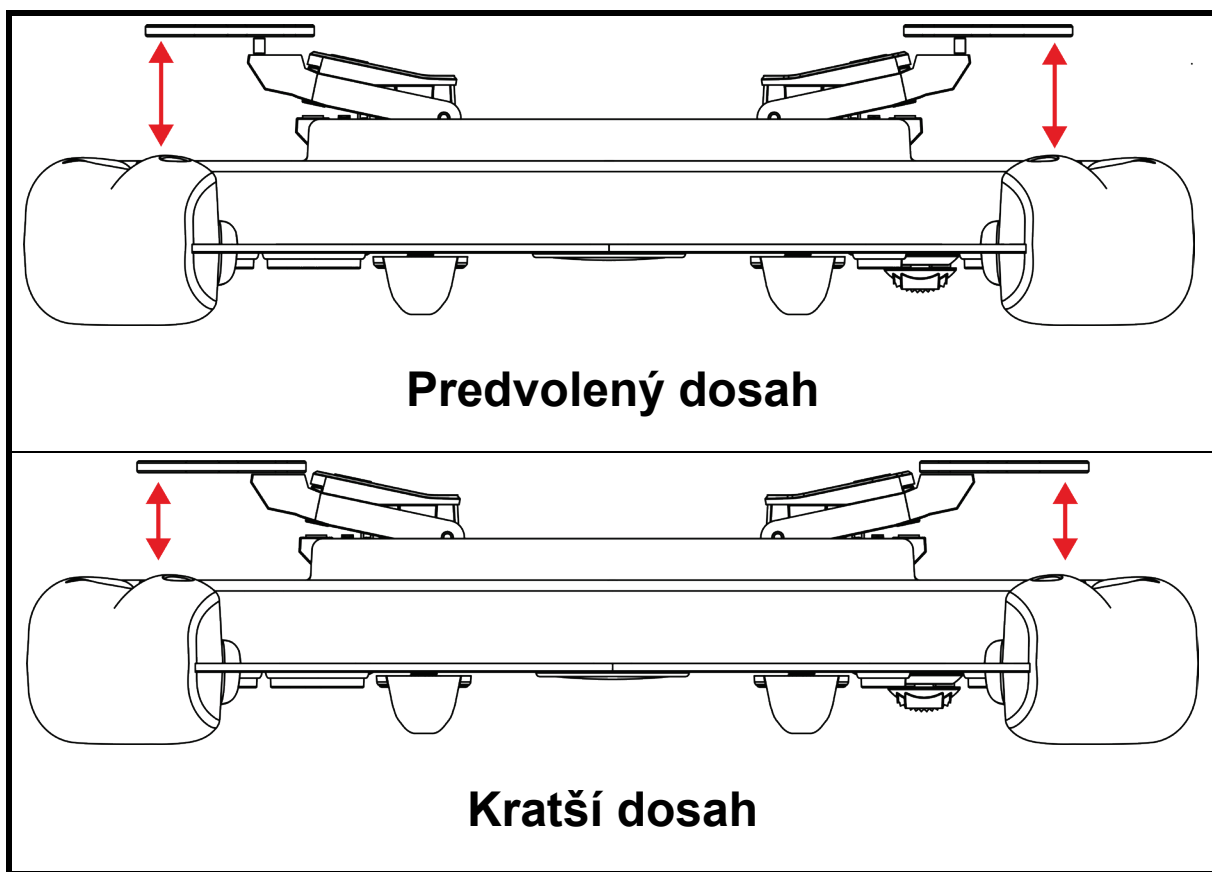

Pomocou dodanej sady padov je tiež možné nastaviť **magnetickú citlivosť** a **úroveň zvuku** produkovaného pádlami radenia.

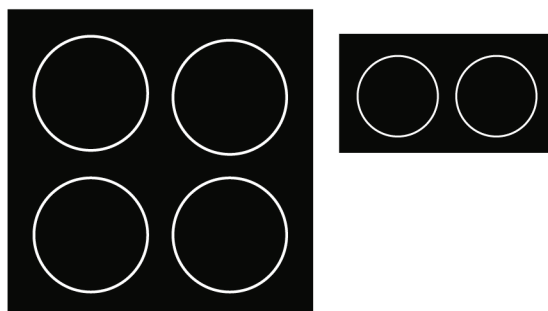



Ako nastaviť rozstup pádla radenia

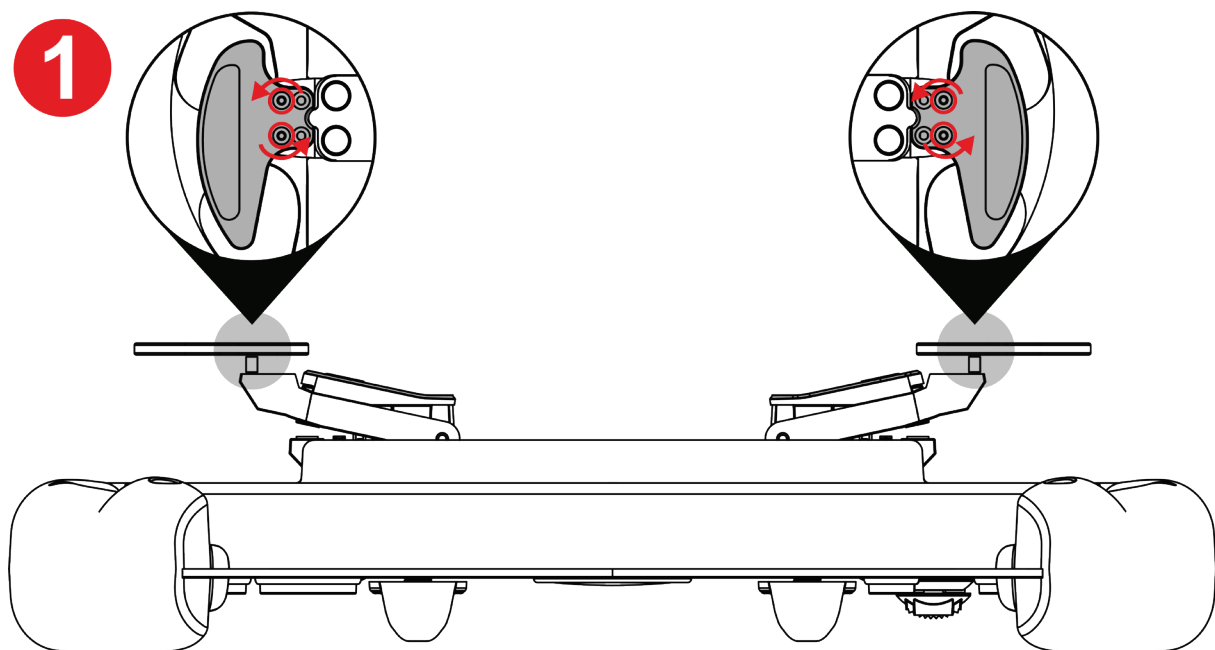

1 Pomocou dodaného kľúča Torx odskrutkujte štyri skrutky pádla radenia.

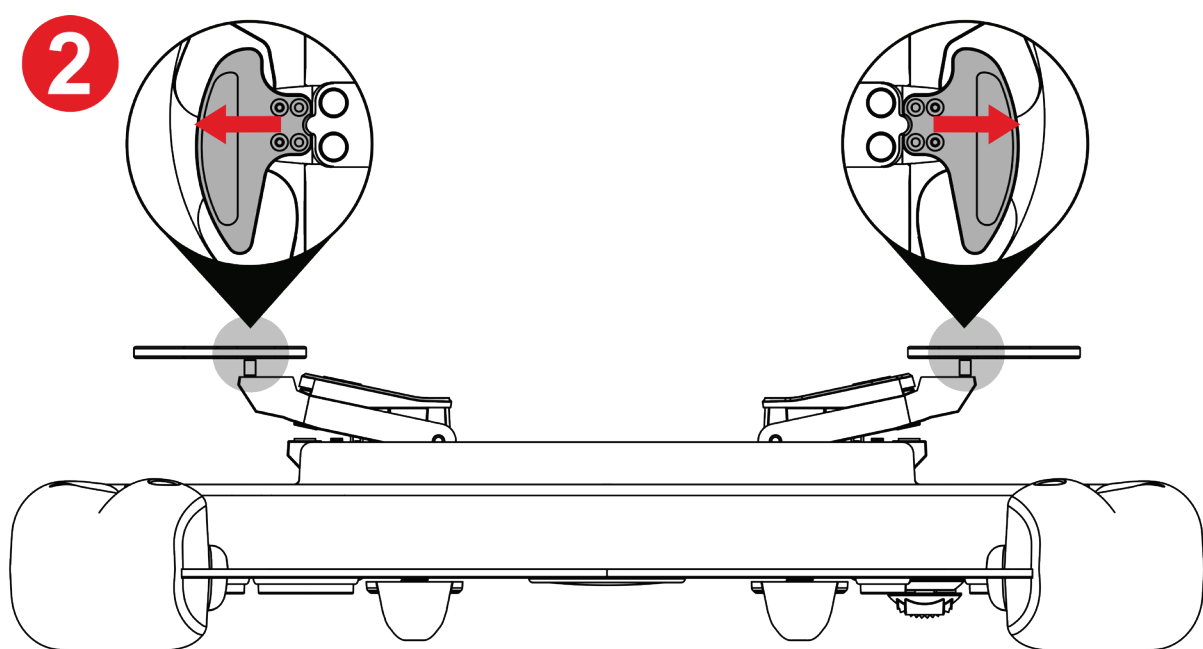

2 Posuňte pádla radenia smerom von, aby zodpovedali otvorom.

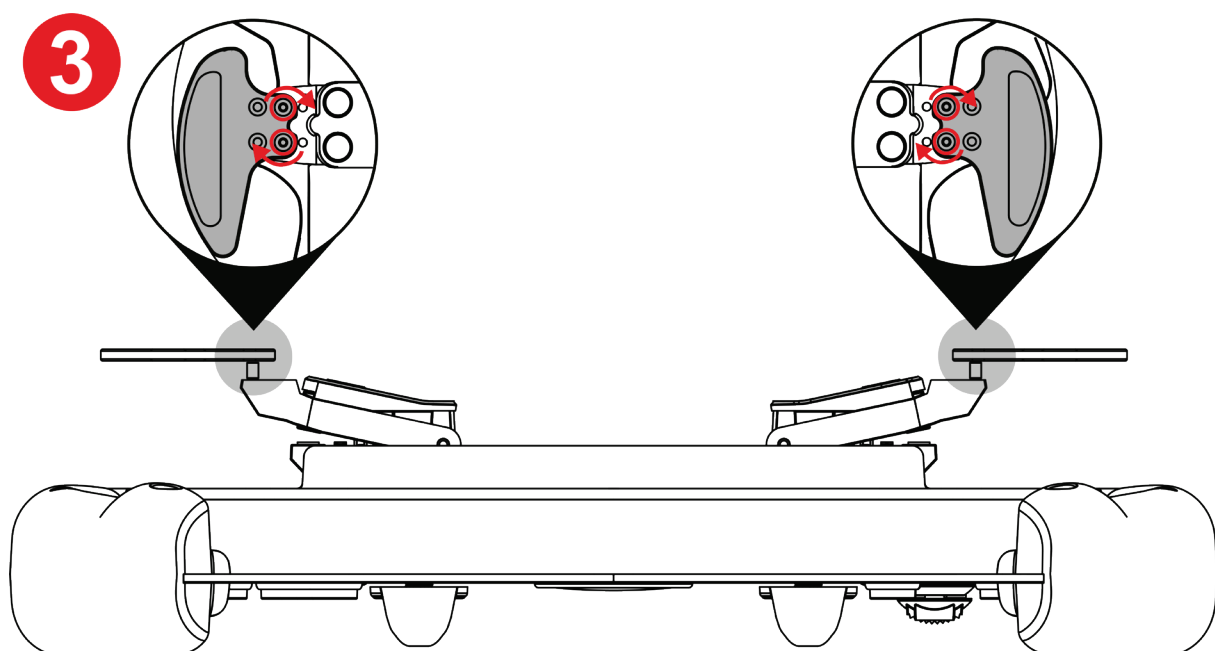

3 Pomocou dodaného kľúča Torx utiahnite štyri skrutky pádla radenia.



Ako nastaviť dosah pádla radenia

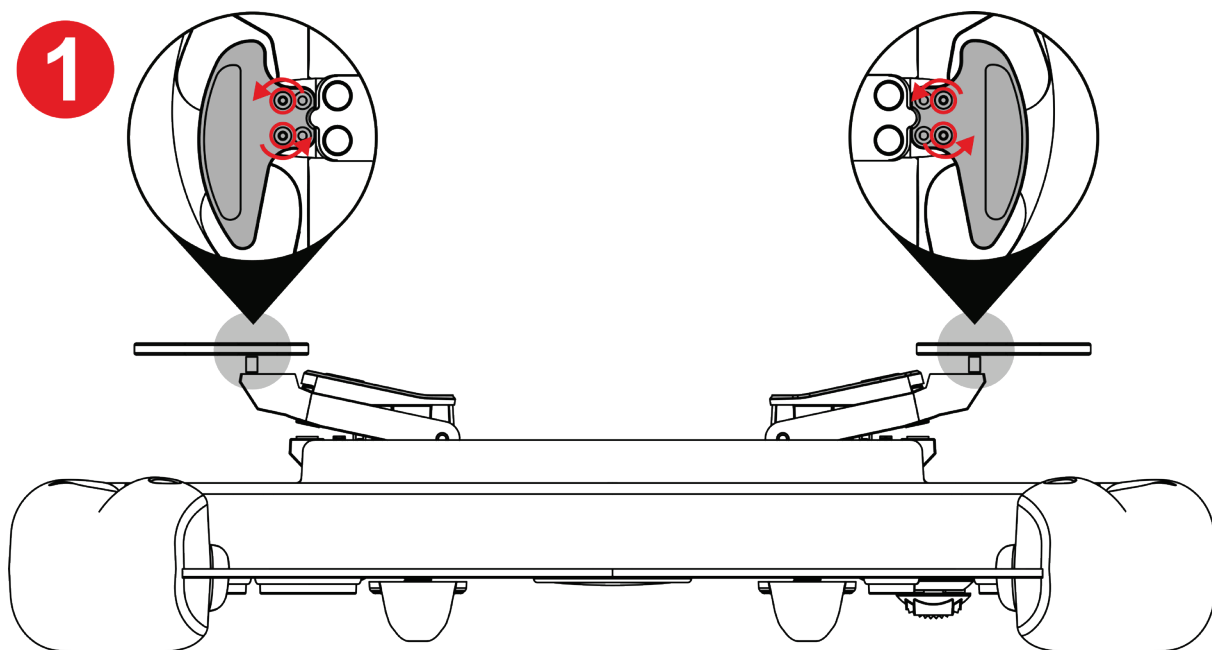

1 Pomocou dodaného kľúča Torx odskrutkujte štyri skrutky pádla radenia.

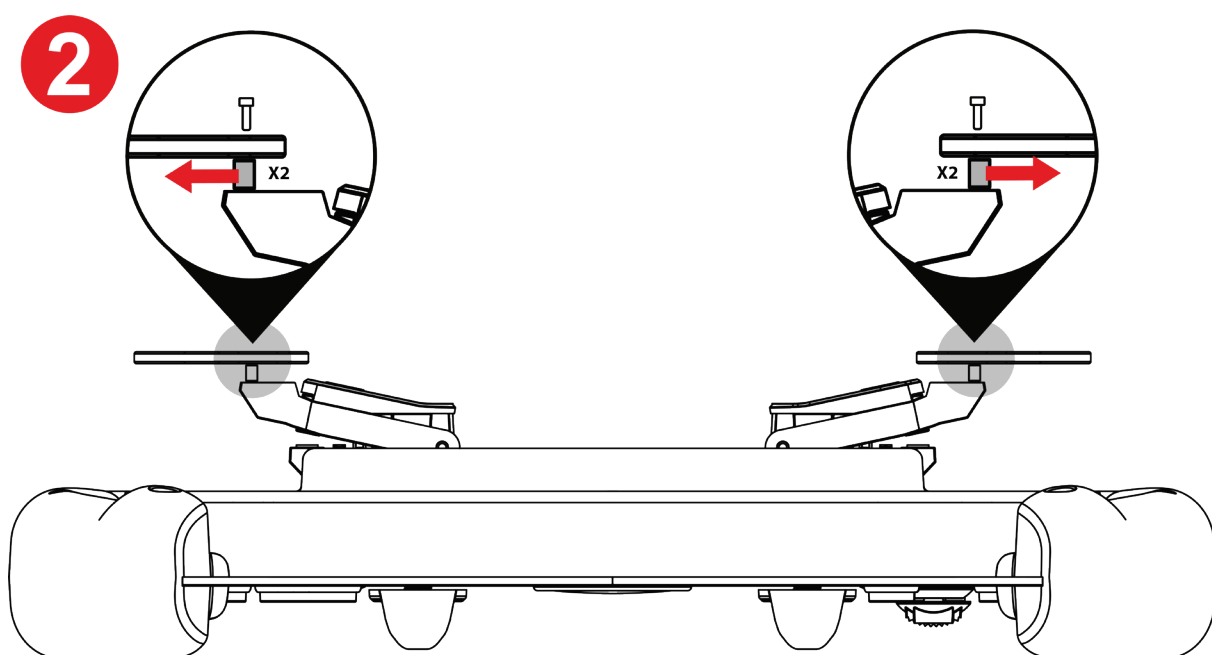

2 Odstráňte vymedzovacie vložky.

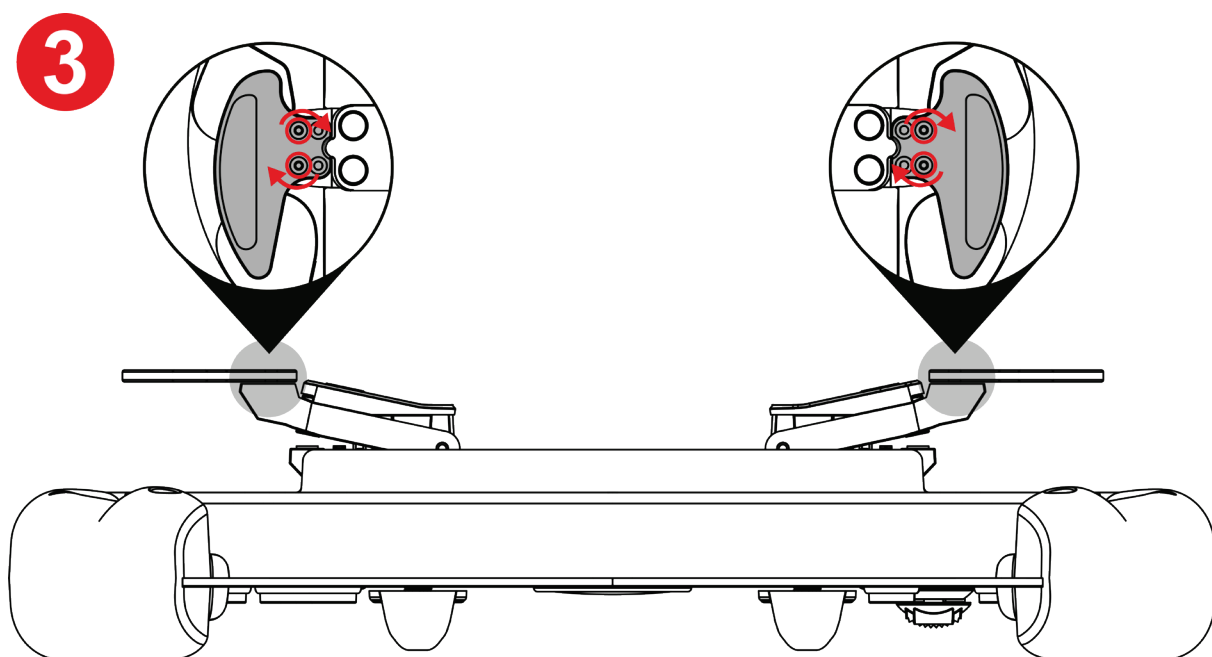

3 Pomocou dodaného kľúča Torx utiahnite štyri skrutky pádla radenia.



Ako nastaviť magnetickú citlivosť a úroveň zvuku pádiel radenia

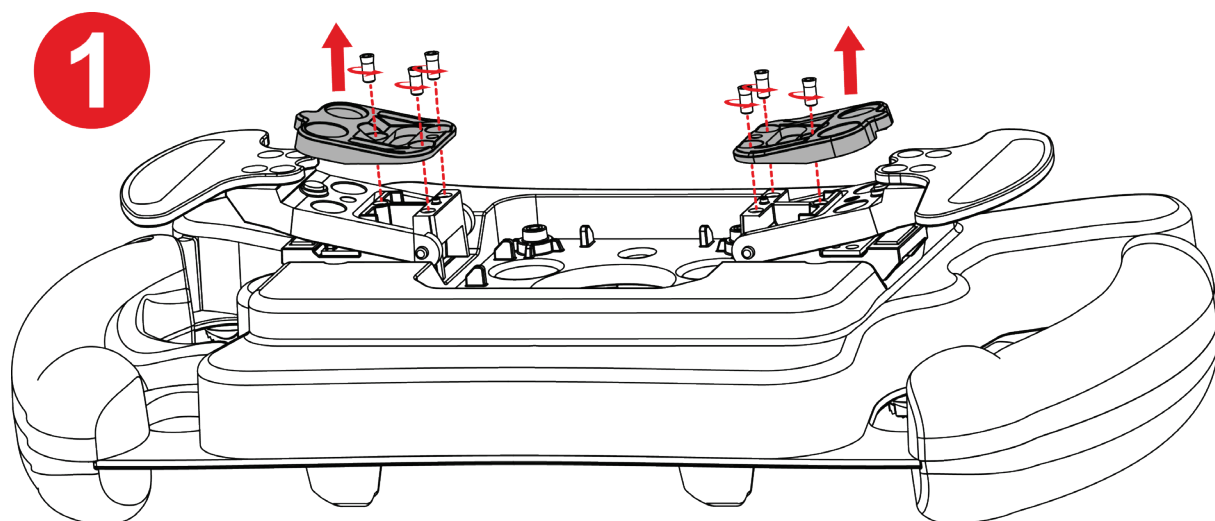

1 Odstráňte magnetické dorazy odskrutkovaním šiestich dorazových skrutiek pomocou dodaného kľúča Torx.

2

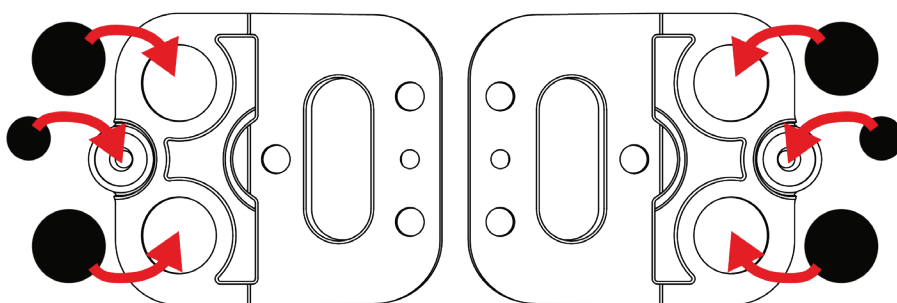

2 Odlepte dodané podložky a pripevnite ich na príslušné miesta pod magnetické zarážky.



Možné konfigurácie a ich efekty nájdete v tabuľke **Magnetická citlivosť a útlm zvuku pádla radenia.**





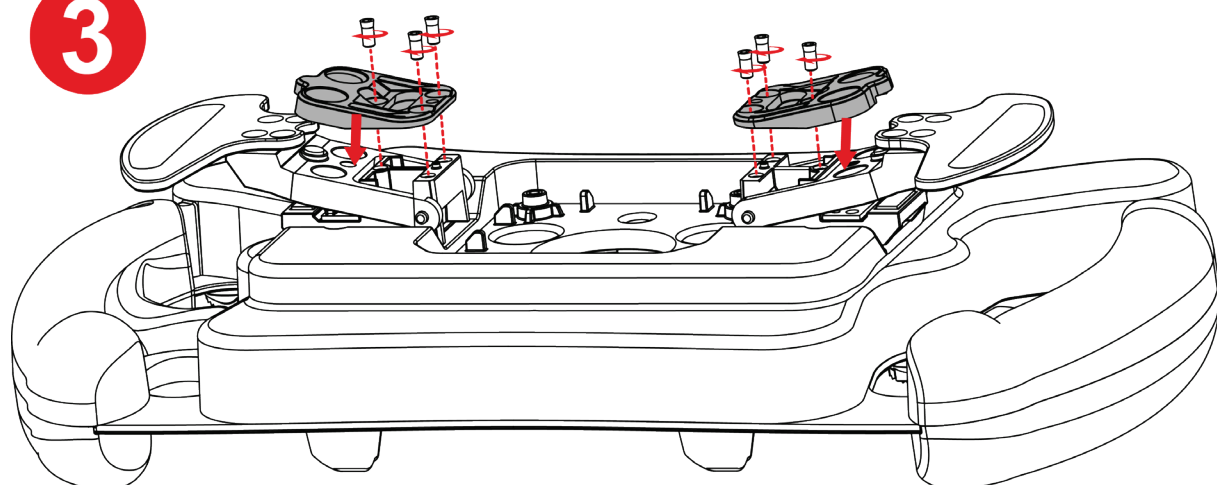

3

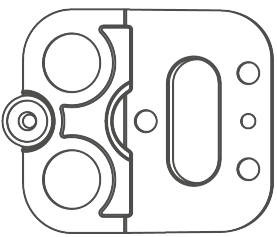
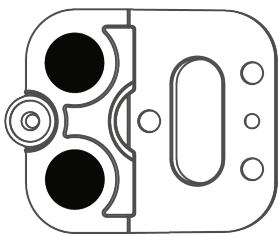
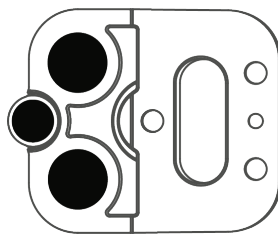

3 Znovu nainštalujte magnetické dorazy a utiahnite šesť dorazových skrutiek pomocou dodaného kľúča Torx.

Tabuľka magnetickej citlivosti a tlmenia zvuku pádla radenia

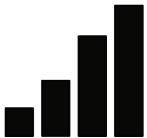
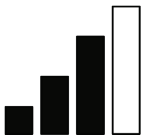
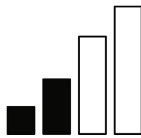
	 (predvolene)		
Magnetická citlivosť			
Zvuk			



8. Často kladené otázky a technická podpora

Máte otázky týkajúce sa Ferrari 488 GT3 Wheel Add-On alebo máte technické problémy? Ak áno, navštívte webovú stránku technickej podpory Thrustmaster:

<https://support.thrustmaster.com/product/ferrarif488gt3addon>.

Na tejto stránke môžete aktualizovať aj firmvér volantu.



THRUSTMASTER®

FERRARI 488 GT3 WHEEL ADD-ON

PC (Windows 10/11)

PS4™ / PS5™

Xbox Series / Xbox One

Használati útmutató



A termék telepítése **előtt**, használata **előtt** és karbantartása **előtt** **figyelmesen olvassa el** a jelen útmutatóban található utasításokat. Feltétlenül tartsa be a biztonsági utasításokat. Az utasítások figyelmen kívül hagyása baleseteket és/vagy károkat okozhat. Őrizze meg ezt az útmutatót, hogy a jövőben hivatkozhatson az utasításokra.

TARTALOMJEGYZÉK

1.	DOBOZ TARTALMA	5
2.	SAJÁTOSSÁGOK	6
3.	A KORMÁNY HASZNÁLATÁRA VONATKOZÓ INFORMÁCIÓK	8
4.	A GYORSKIOLDÓ TARTÓ FELSZERELÉSE	13
	<i>A gyorskioldó tartó felszerelése reteszes alaphoz</i>	<i>14</i>
	<i>A gyorskioldó tartó felszerelése csavaros alaphoz</i>	<i>17</i>
5.	GOMBKIOSZTÁS	21
	<i>Gombkiosztás PC-n</i>	<i>21</i>
	<i>Gombkiosztás PS4™/PS5™-ön</i>	<i>22</i>
	<i>Gombkiosztás Xbox Series/Xbox One-on</i>	<i>23</i>
6.	LED MŰKÖDÉS	24
	<i>Be -és kilépés a LED menübe</i>	<i>25</i>

A LED erősség beállítása27

A LED mód megváltoztatása: GT3 vagy

Formula28

7. A KORMÁNYVÁLTÓK TESTRE

SZABÁSA.....29

A kormányváltó távolság beállítása31

A kormányváltók elérésitávolságának

beállítása33

A mágneses érzékenység és a

kormányváltók hangszintjének

beállítása35

8. GYIK ÉS TECHNIKAI TÁMOGATÁS.....37



FERRARI 488 GT3 WHEEL ADD-ON

Legyen részese a GT versenyzés legendájának a Ferrari 488 GT3 Wheel Add-On-al, amelyet teljesítményre terveztek, és amely kompatibilis az összes Thrustmaster kormány alappal.

Ez az útmutató segít a Ferrari 488 GT3 Wheel Add-On felszerelésében és használatában a legjobb körülmények között. Mielőtt elkezdené a versenyzést, olvassa el figyelmesen az utasításokat és a figyelmeztetéseket: ezek segítenek abban, hogy a lehető legtöbbet hozza ki a termékből.



1. Doboz tartalma

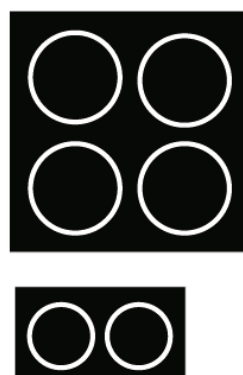
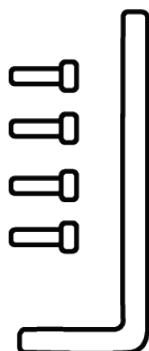
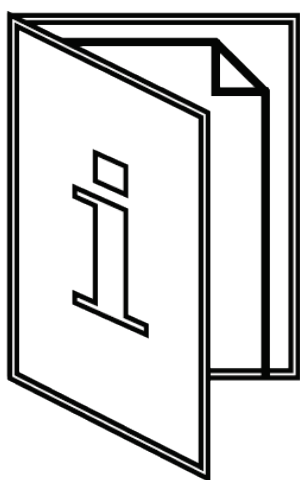
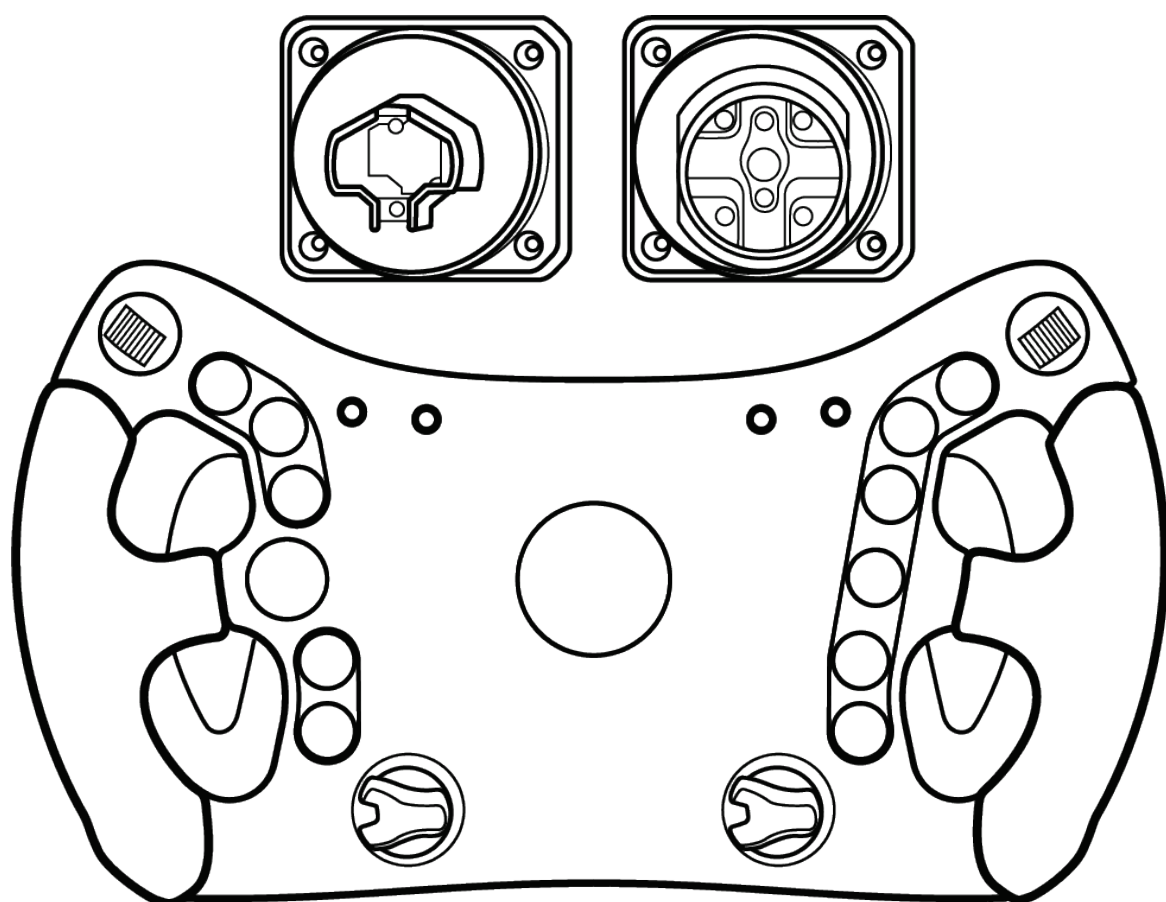



2. Sajátosságok

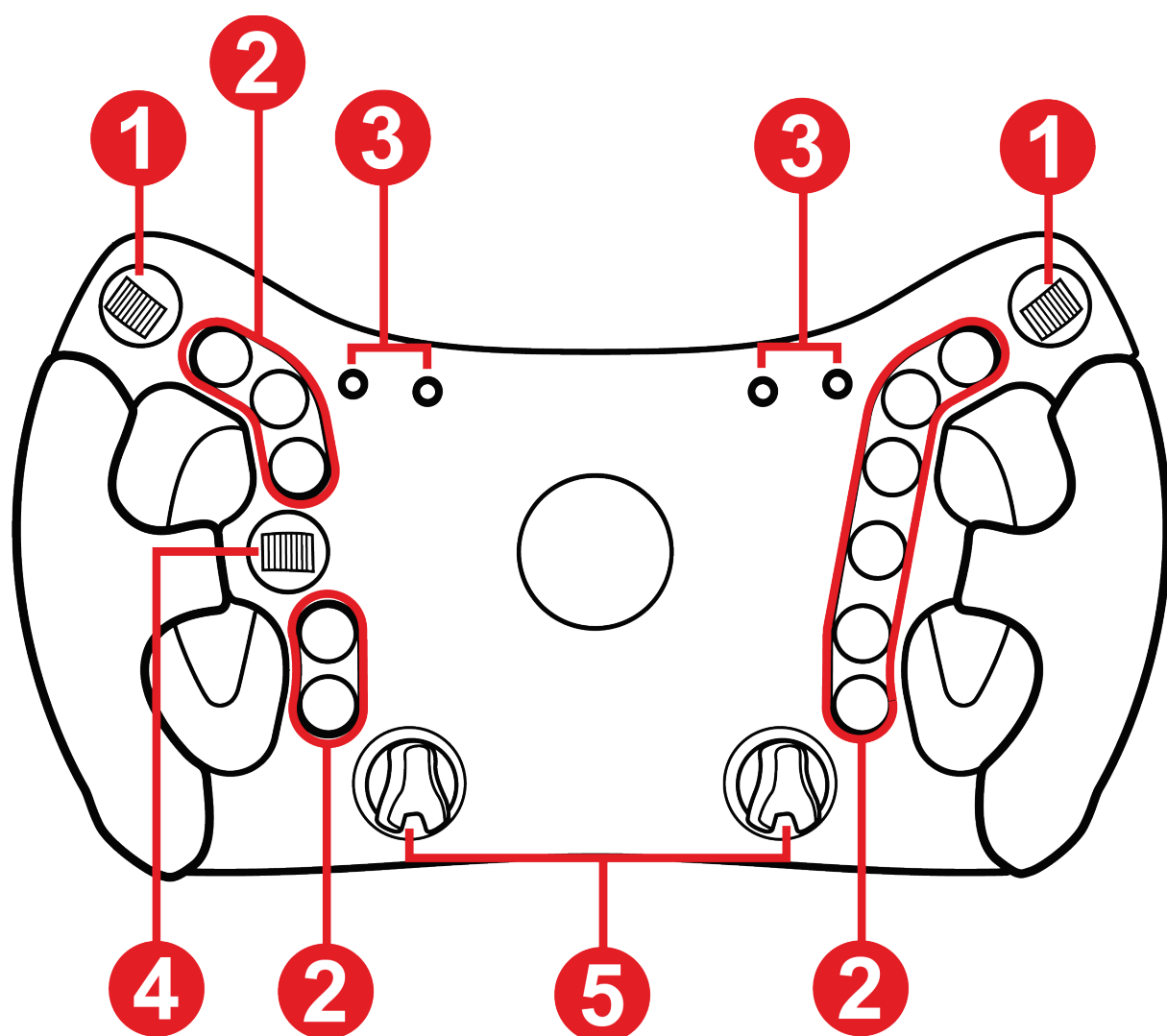

❶ Hüvelykujjas kapcsolók

❷ 11 akciógomb

❸ Fordulatszám LED-ek és versenyadatok (zászlók, box adatok)

❹ D-pad

❺ Forgókapcsolók

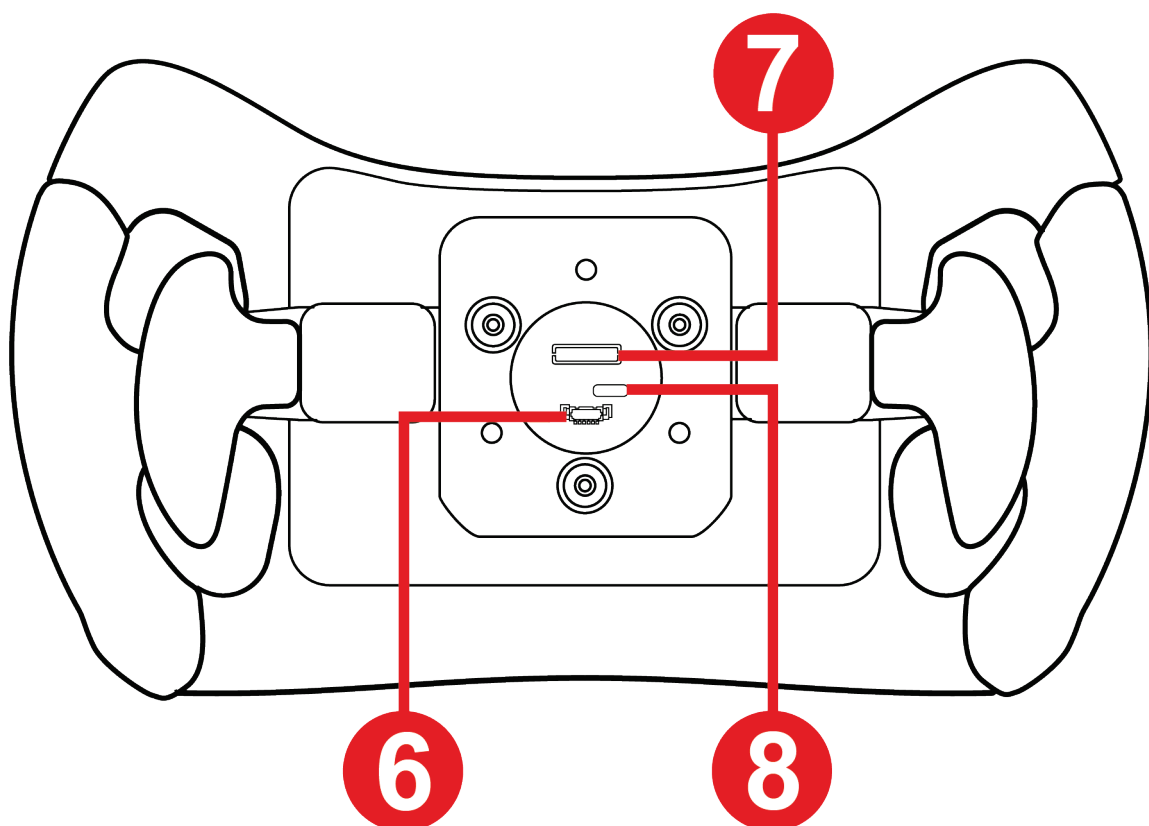

⑥ Csatlakozónyílás a csavaros alap gyorskioldó tartójához

⑦ Csatlakozónyílás a reteszkes alap gyorskioldó tartójához

⑧ USB-C port (ha firmware frissítésre van szükség - a kábel nem tartozék)

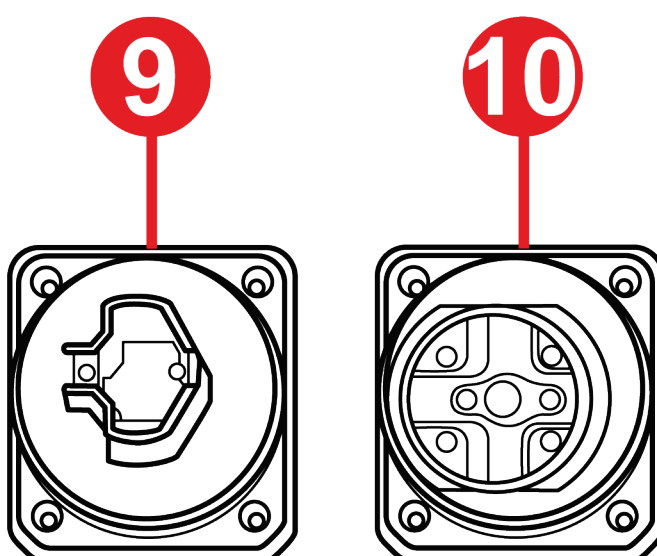

⑨ Gyorskioldó tartó reteszkes alaphoz

⑩ Gyorskioldó tartó csavaros alaphoz



3. A kormányhasználatára vonatkozó információk



Dokumentáció

A termék használata előtt olvassa el még egyszer figyelmesen ezt a dokumentációt, és őrizze meg a későbbi használatra.



Elektromos áramütés

- Tartsa a terméket száraz helyen és ne tegye ki pornak vagy napfénynek.
- Ne csavarja vagy húzza meg a csatlakozót és kábelt.
- Tartsa be a csatlakoztatási utasításokat.
- A termék vagy a csatlakozója ne érintkezzen folyadékkal.
- Ne zárja rövidre a terméket.
- Ne szedje szét a terméket (a jelen útmutatóban leírt esetleges beállítások kivételével), ne tegyen kísérletet a termék elégetésére, és ne tegye ki a terméket magas hőmérsékletnek.
- Ne nyissa fel a készüléket: a készülékben nincsenek a felhasználó által szervizelhető alkatrészek. Bármilyen javítást a gyártónak, egy meghatározott képviselőnek vagy szakképzett szakembernek kell elvégeznie.



A játéktér biztosítása

- Ne helyezzen el a játéktérben olyan tárgyat, amely zavarhatja a felhasználó gyakorlását, vagy amely nem megfelelő mozgást vagy más személy általi megszakítást idézhet elő (például kávéscsésze, telefon, kulcsok).
- Ne takarja le az elektromos kábeleket szőnyeggel, takaróval, illetve ne fedje le semmilyen más tárggyal, és ne helyezzen el kábeleket olyan helyre, ahol emberek járkálnak.



A Force Feedback használatából és ismétlődő mozgásokból eredő sérülések

A Force Feedback versenykormány használata izom- és ízületi fájdalmakat okozhat. A problémák elkerülése érdekében:

- Melegítsen be, és kerülje a hosszabb ideig tartó gyakorlást.
- Tartson 10-15 perc szünetet minden óra gyakorlás után.
- Ha fáradtságot vagy fájdalmat észlel a kezében, csuklójában, karjában, lábfejében vagy lábában nyomja meg a Force Feedback kikapcsoló gombot, kapcsolja ki az alapot és pihenjen néhány órát, mielőtt újra kezdené a gyakorlást.
- Ha a fent leírt tünetek vagy fájdalmak a gyakorlás folytatásakor is fennállnak, hagyja abba a gyakorlást, és forduljon orvosához.
- Ne állítsa az Force Feedback-et a szaktudásához és fizikai állapotához képest túl magas szintre.
- Tartsa az eszközt 16 évnél fiatalabbak számára elérhetetlen helyen.
- Győződjön meg arról, hogy az alap és a kormány megfelelően, az útmutató utasításainak megfelelően van rögzítve.



Váratlan, erőteljes és gyors forgás veszélye: soha ne tegye a kezét vagy a karját a kormány peremén lévő nyílásokba vagy a kerék forgási pályájának irányába.

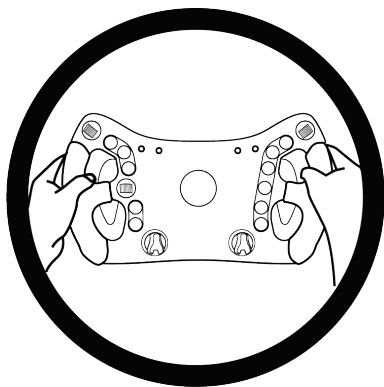

A termék használatakor mindig hagyja mindkét kezét megfelelően a kormányon, anélkül, hogy teljesen elengedné.



A terméket csak **16 éves vagy idősebb** személyek kezelhetik.



4. A gyorskioldó tartó felszerelése

A **Ferrari 488 GT3 Wheel Add-On** a Thrustmaster alap formátumainak megfelelő két gyorskioldó tartót tartalmaz.

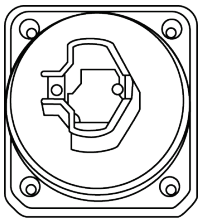
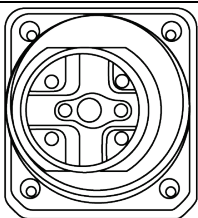
Rendszer	Kompatibilitás
 <p>Gyorskioldó tartó reteszes alaphoz</p>	T818, T818 Ferrari SF1000 Simulator és jövőbeni Thrustmaster alapok.
 <p>Gyorskioldó tartó csavaros alaphoz</p>	T-GT / T-GT II Servo Base, T300 RS Servo Base, TS PC Racer, TS-XW, TX Racing Wheel Servo Base, TS-XW Servo Base.



Minden használat előtt ellenőrizze, hogy a **Ferrari 488 GT3 Wheel Add-On** megfelelően van rögzítve a tartóhoz, az útmutatóban az alapra vonatkozó utasításoknak megfelelően.



A gyorskioldó tartó felszerelése retesz alaphoz

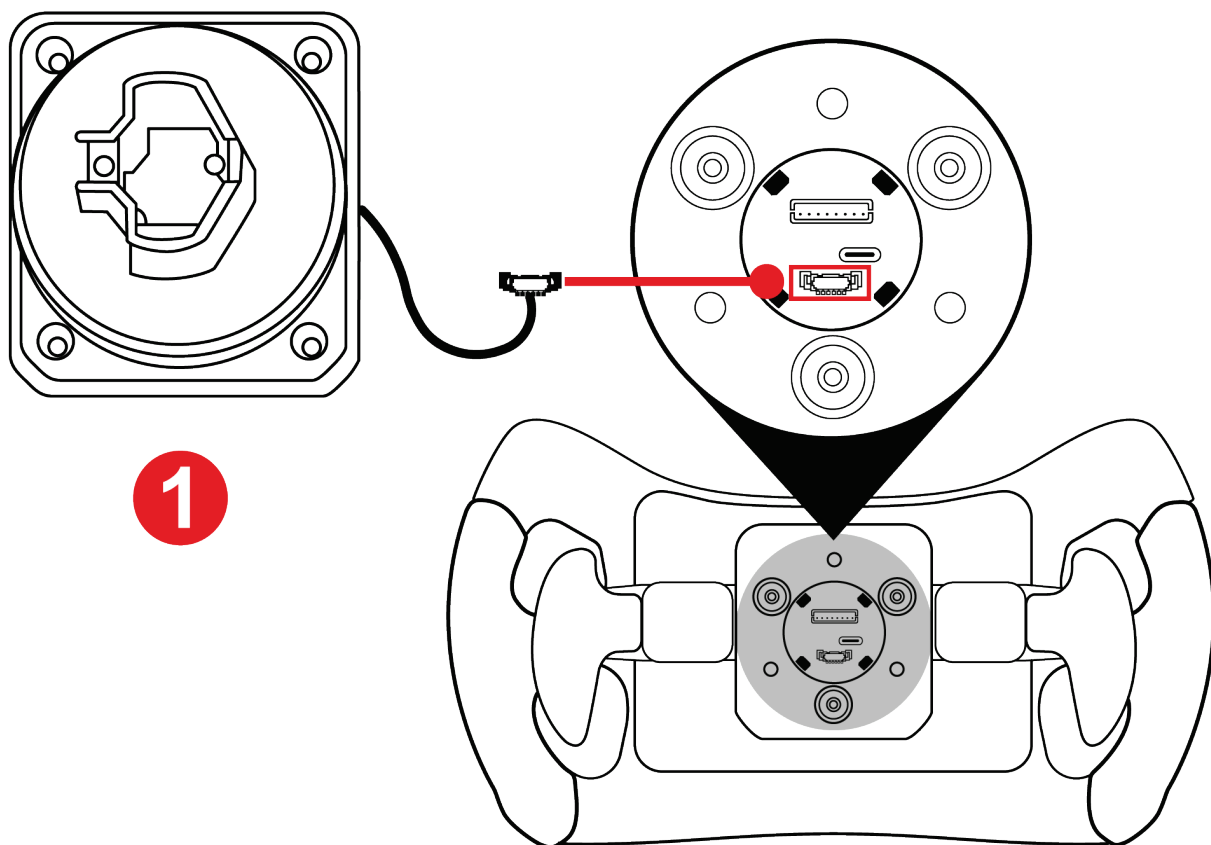

1

1 Csatlakoztassa a gyorskioldó tartó csatlakozóját a kormány hátulján lévő megfelelő porthoz.



A kábelbecsípődés elkerülése érdekében húzza vissza azt a házba, mielőtt becsavarja a tartót.

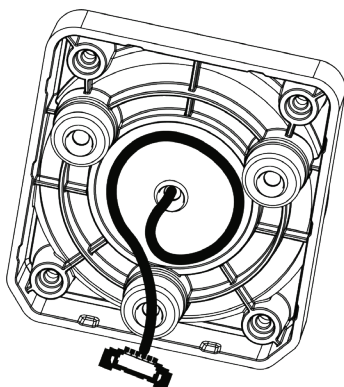

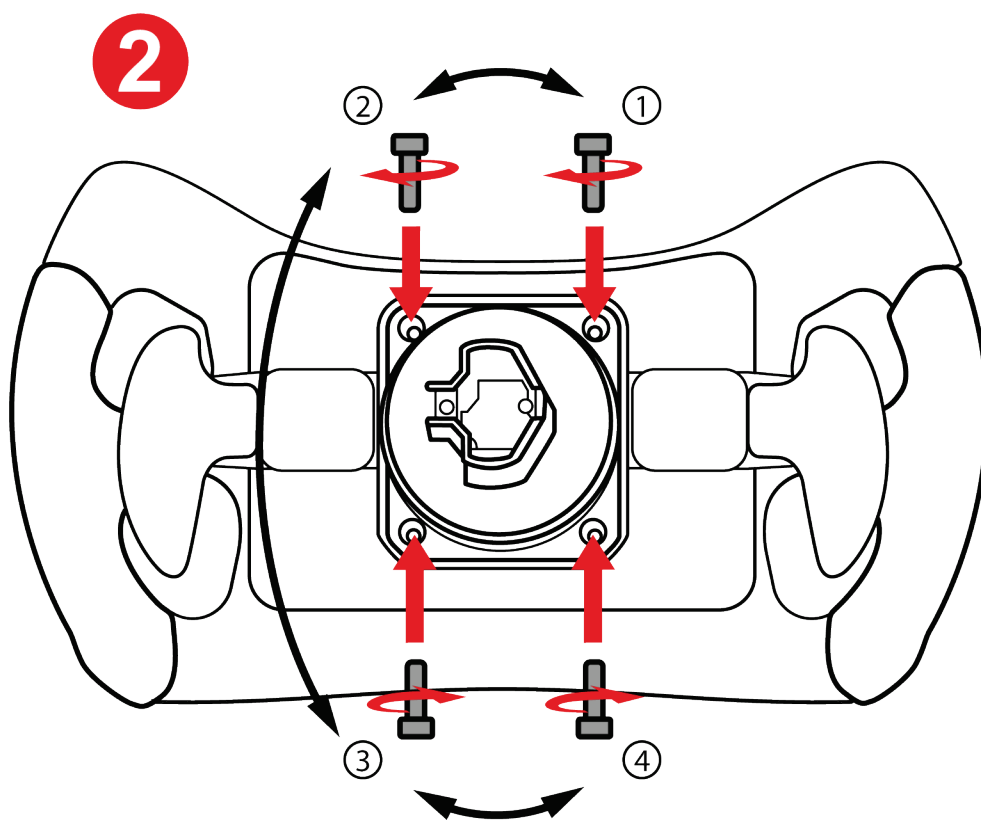

2 Helyezze be a gyorskioldó tartót, és húzza meg a mellékelt Torx kulccsal.



A tartó felszerelésekor ne húzza túl a csavarokat.

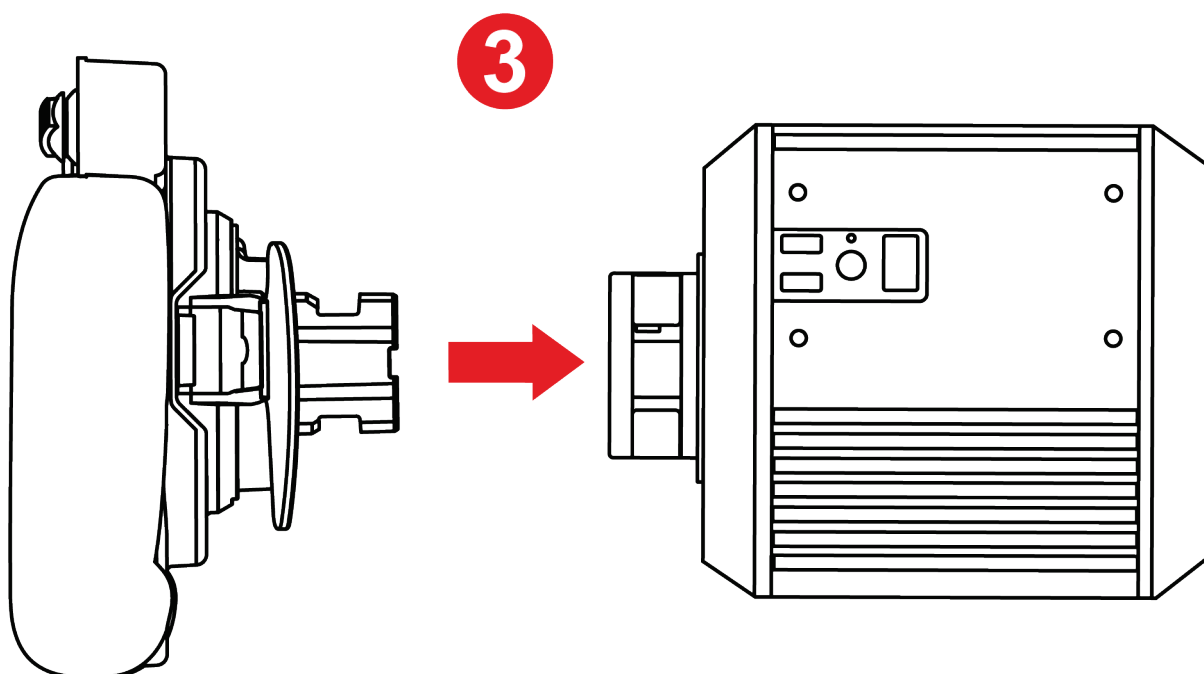

3 Rögzítse a kormányt az alaphoz.



Kövesse az alap használati útmutatójában meghatározott üzembehelyezési eljárást.



A gyorskioldó tartó felszerelése csavaros alaphoz

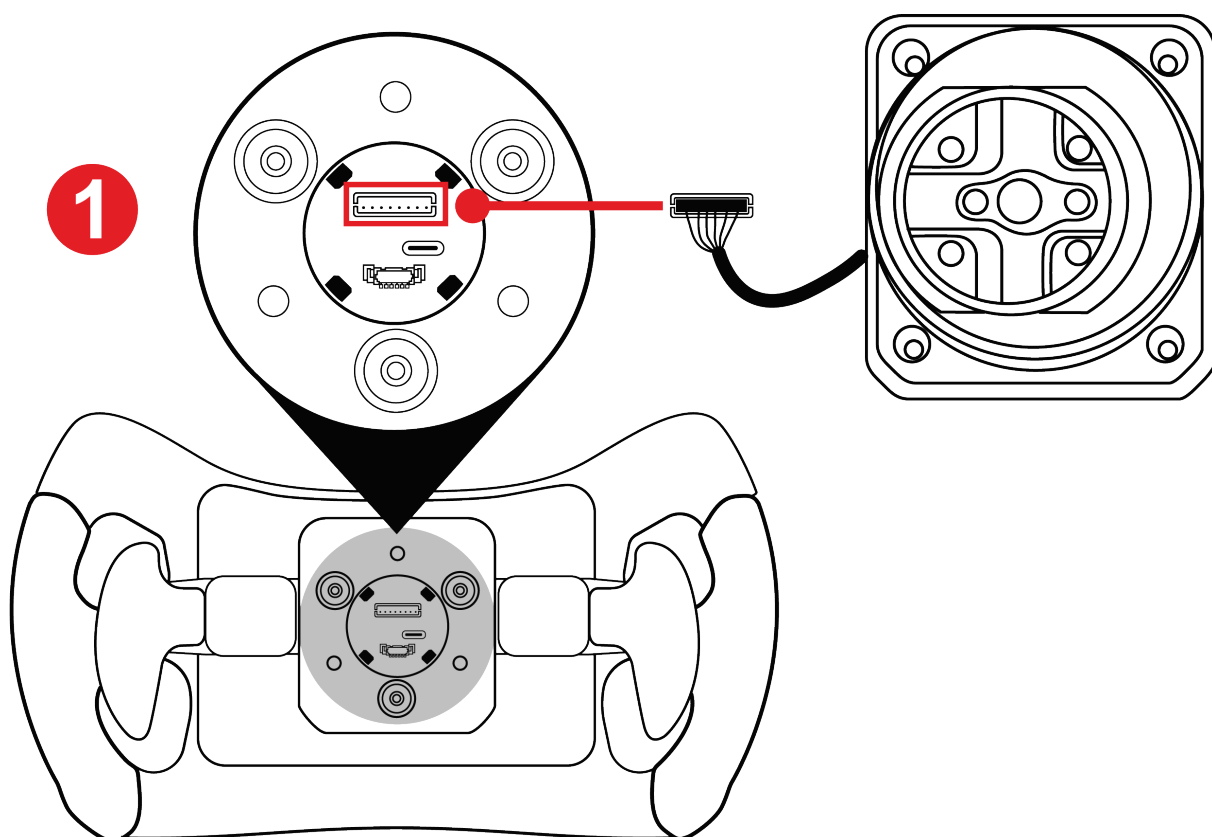

1 Csatlakoztassa a gyorskioldó tartó csatlakozóját a kormány hátulján lévő megfelelő porthoz.



A kábelbecsípődés elkerülése érdekében húzza vissza azt a házba, mielőtt becsavarja a tartót.

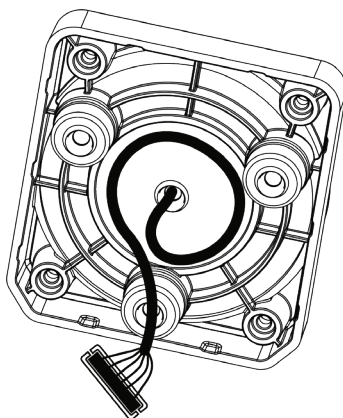

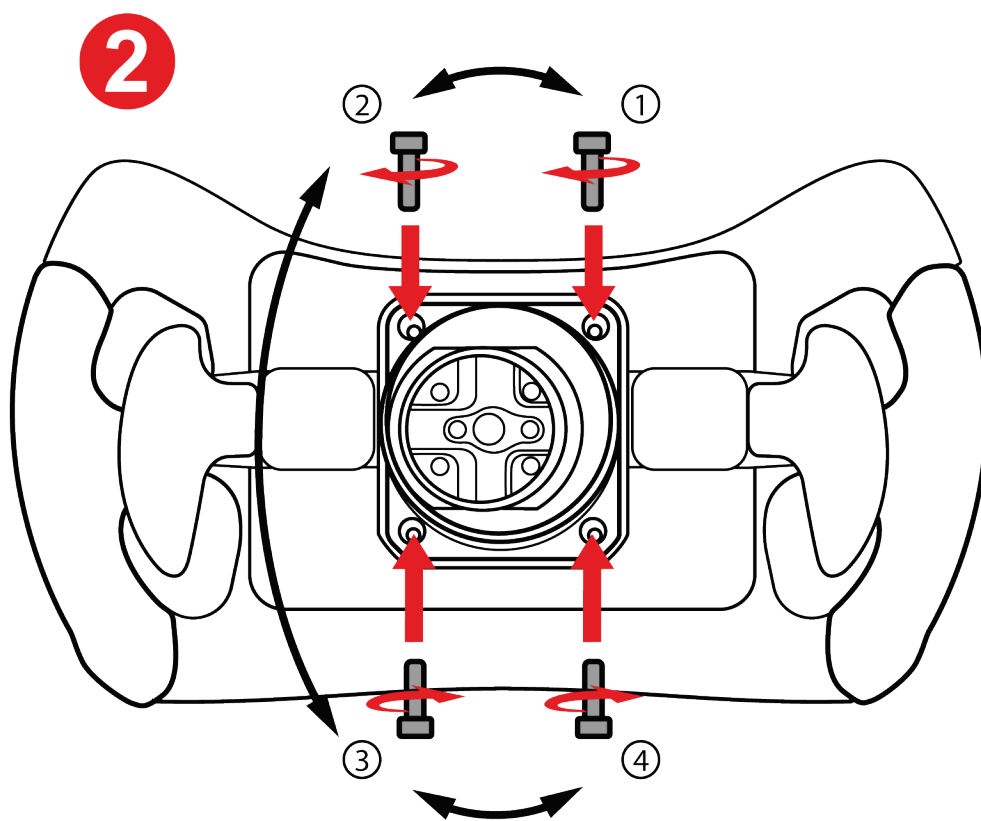

2 Helyezze be a gyorskioldó tartót, és húzza meg a mellékelt Torx kulccsal.



A tartó felszerelésekor ne húzza túl a csavarokat.

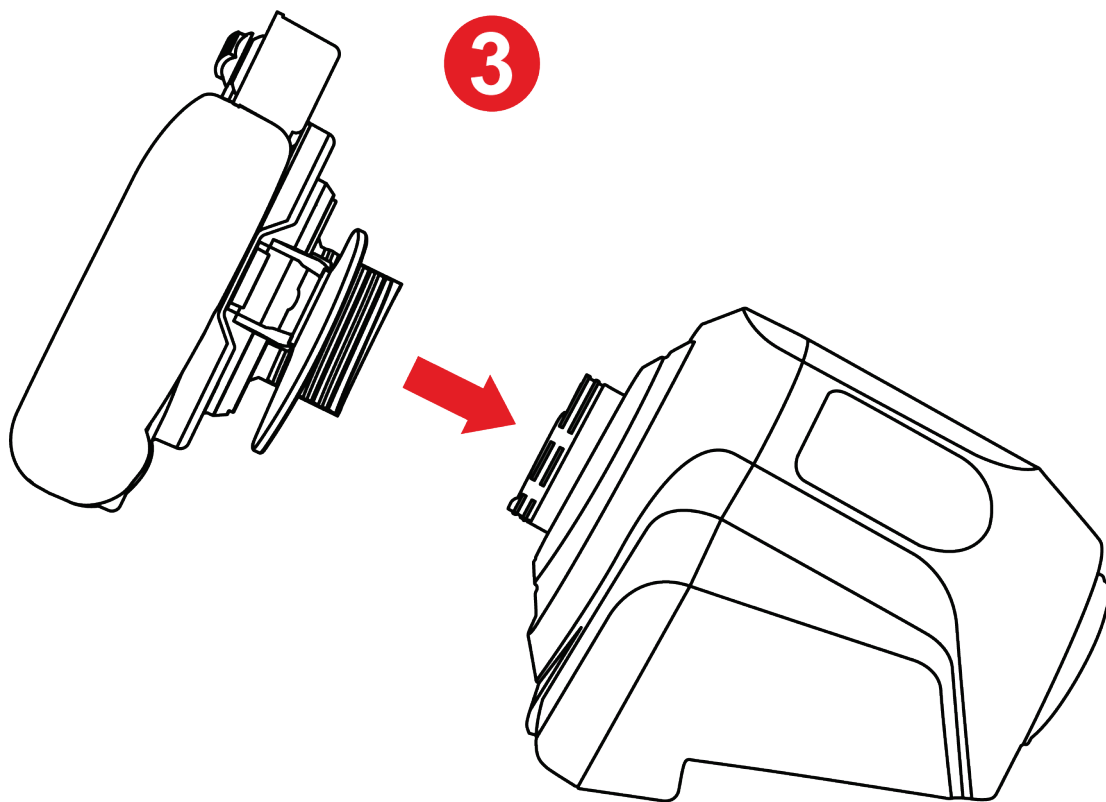

3 Rögzítse a kormányt az alaphoz.



Kövesse az alap használati útmutatójában meghatározott üzembehelyezési eljárást.



Soha ne csatlakoztassa a Gyorskioldó Adaptert (a T818 alaphoz mellékelt és külön kapható) a csavaros alaphoz tartozó gyorskioldóhoz, ha azt a T818 alapon kívánja használni.

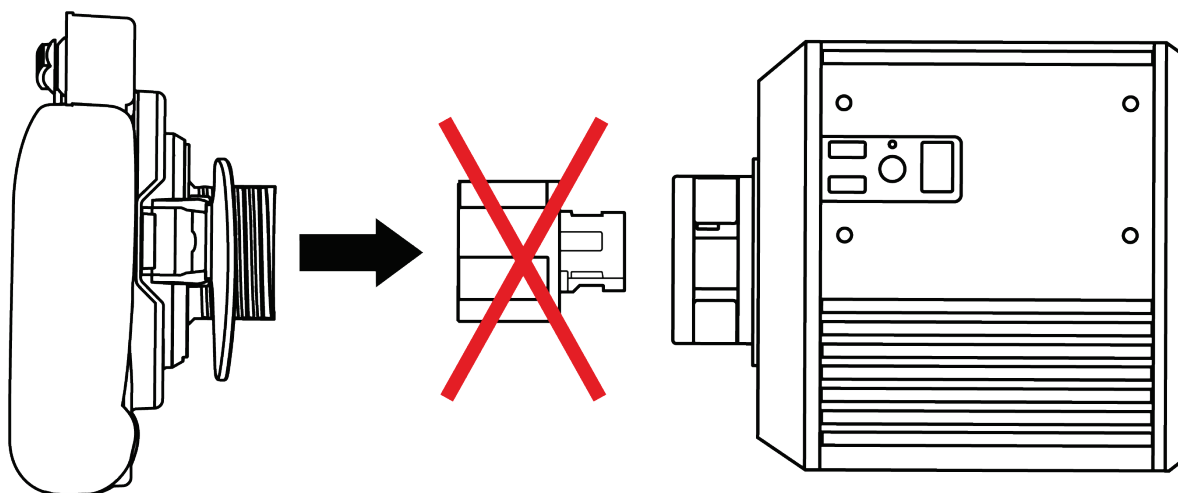
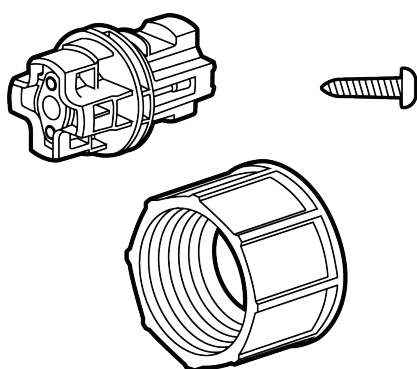

A T818 alapon vagy a retesz alaphoz csatlakozóval felszerelt alapon történő használathoz csak a **Ferrari 488 GT3 Wheel Add-On-hoz** mellékelt **gyorskioldó tartót retesz alaphoz** használja.



5. Gombkiosztás

Gombkiosztás PC-n

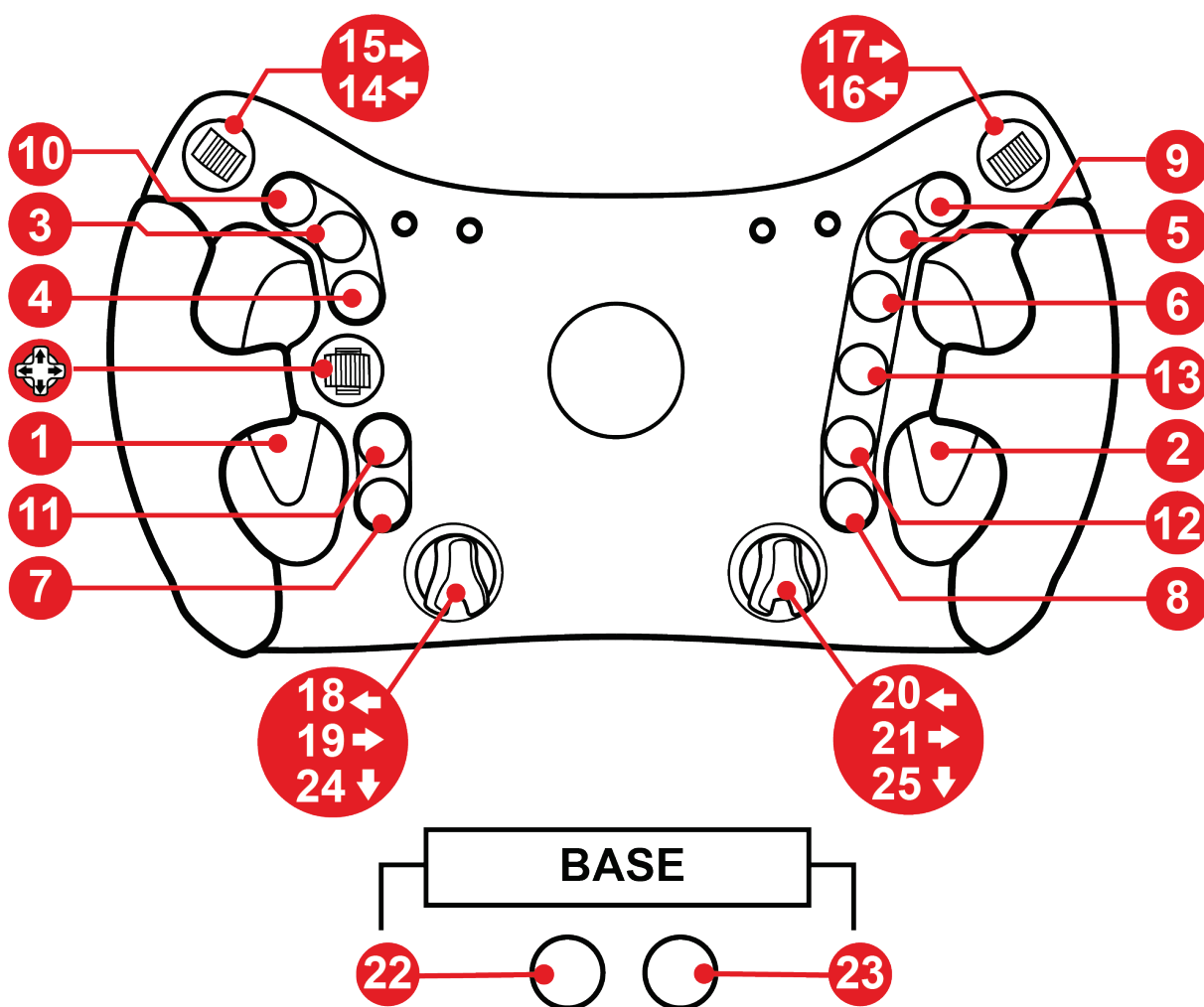



Gombkiosztás PS4™/PS5™-ön

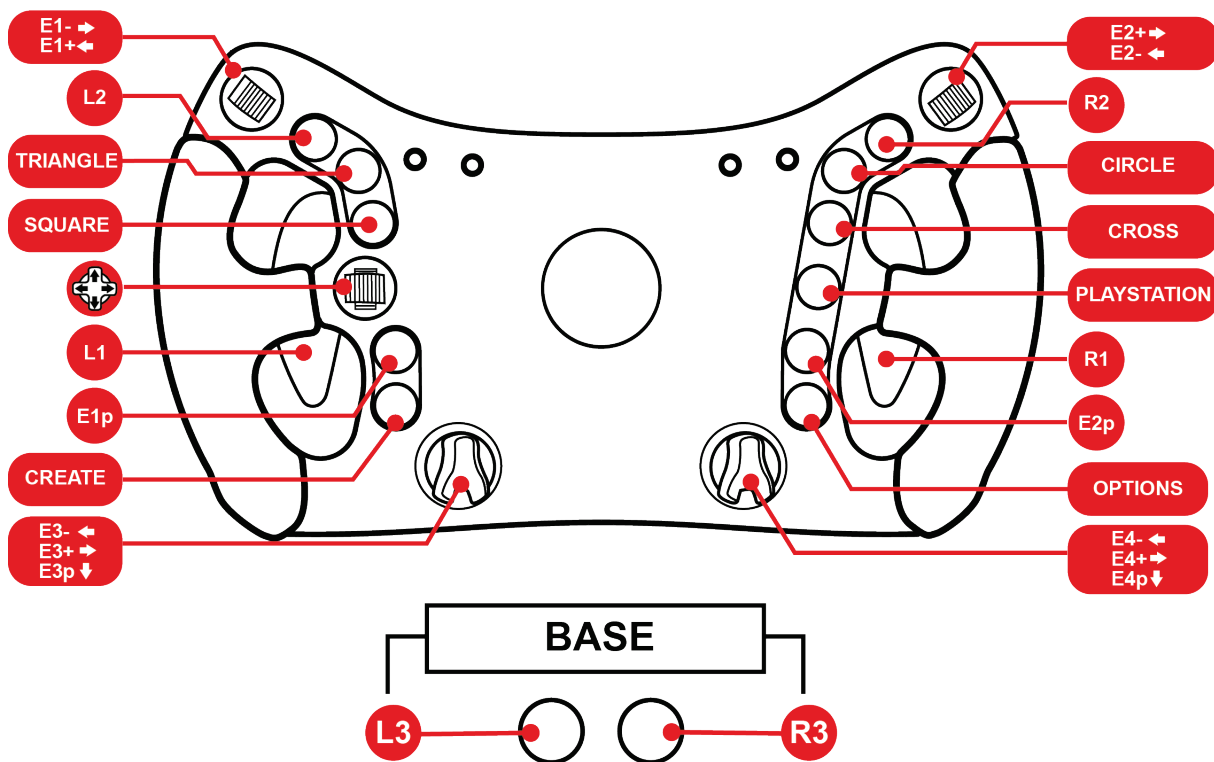



Gombkiosztás Xbox Series/Xbox One-on

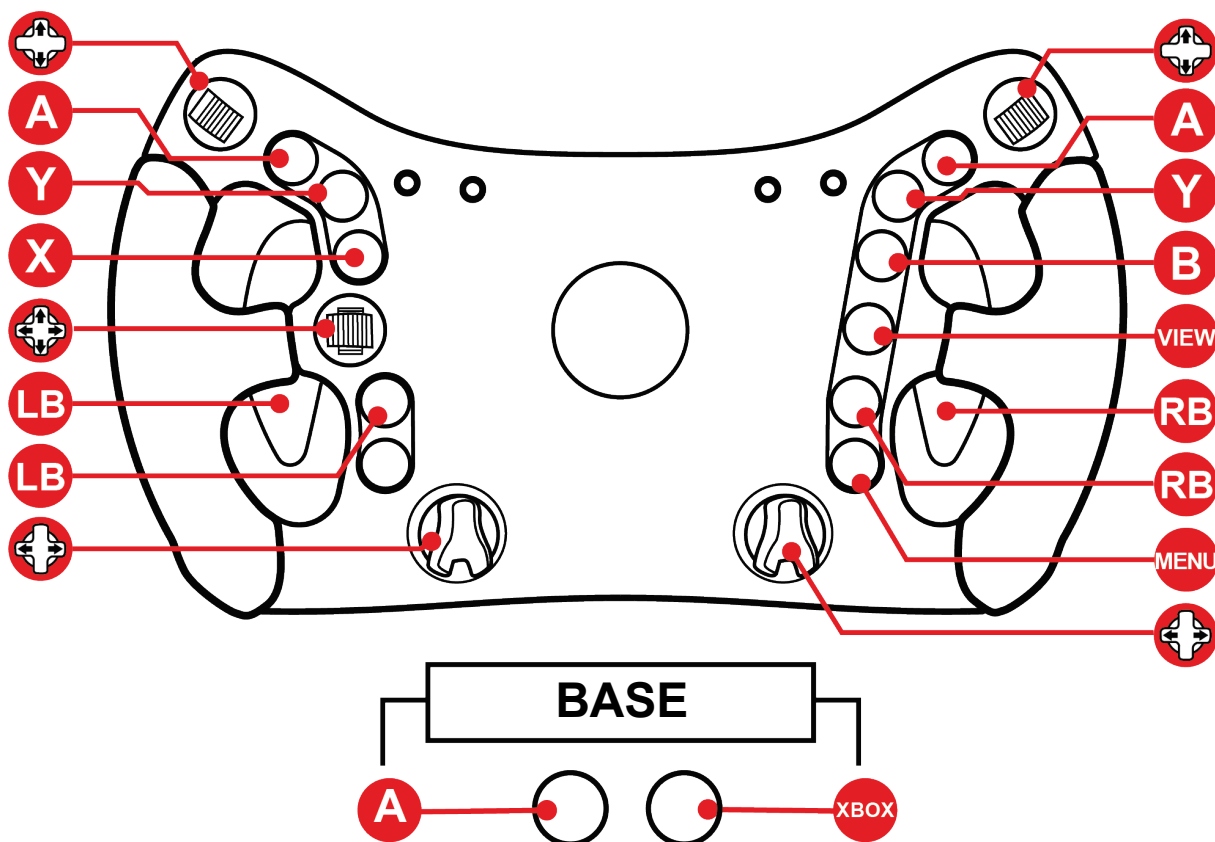

Xbox Series-en és Xbox One-on:

- A Ferrari 488 GT3 Wheel Add-On LED-jei nem működnek a konzolprotokoll korlátozása miatt.
- Egyes funkciókat (forgókapcsolók, gombok száma) a konzolprotokoll korlátoz.



6. LED működés

A **Ferrari 488 GT3 Wheel Add-On** a LED-eken keresztül mutatja a versenyadatokat: zászló, box kiállítás és fordulatszám.

A megjelenített adatok testre szabhatók (a fordulatszám LED-ek intenzitása és színe), a módtól függően (GT3 vagy Formula).

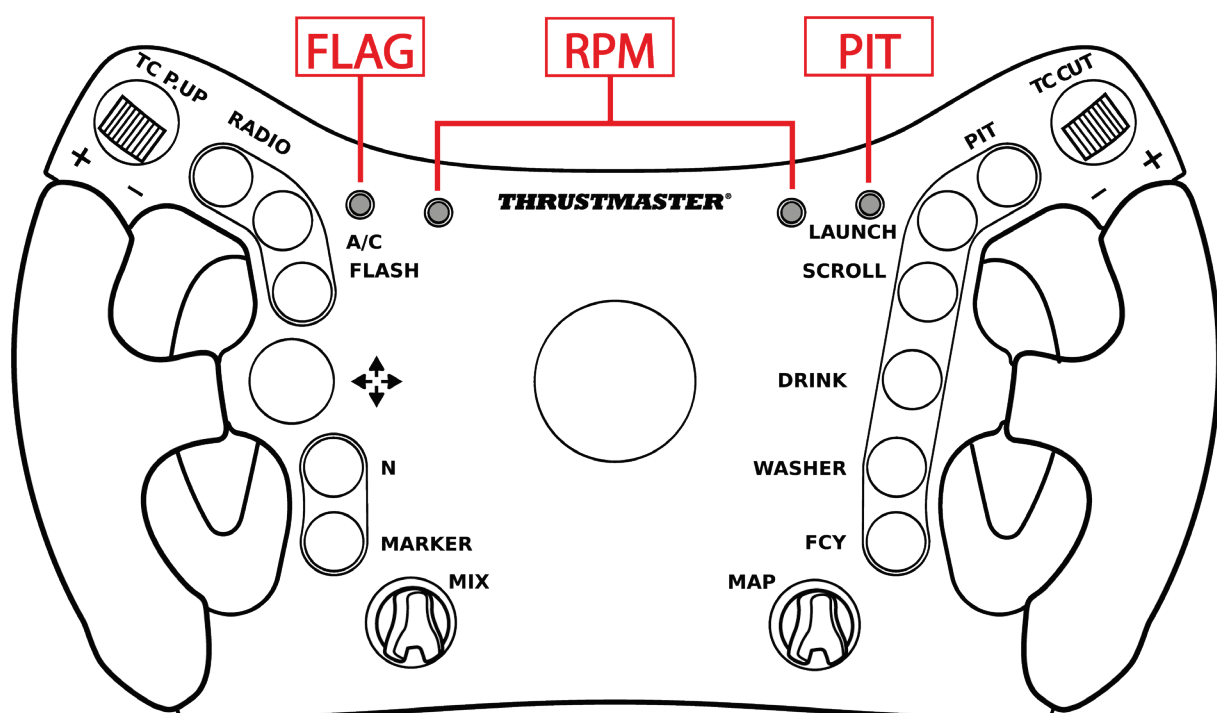

A LED-ek PC-n és PS4™/PS5™ konzolokon is működnek.

Xbox Series és Xbox One konzolokon a LED-ek nem működnek a konzol protokollkorlátozásai miatt.



Be -és kilépés a LED menübe

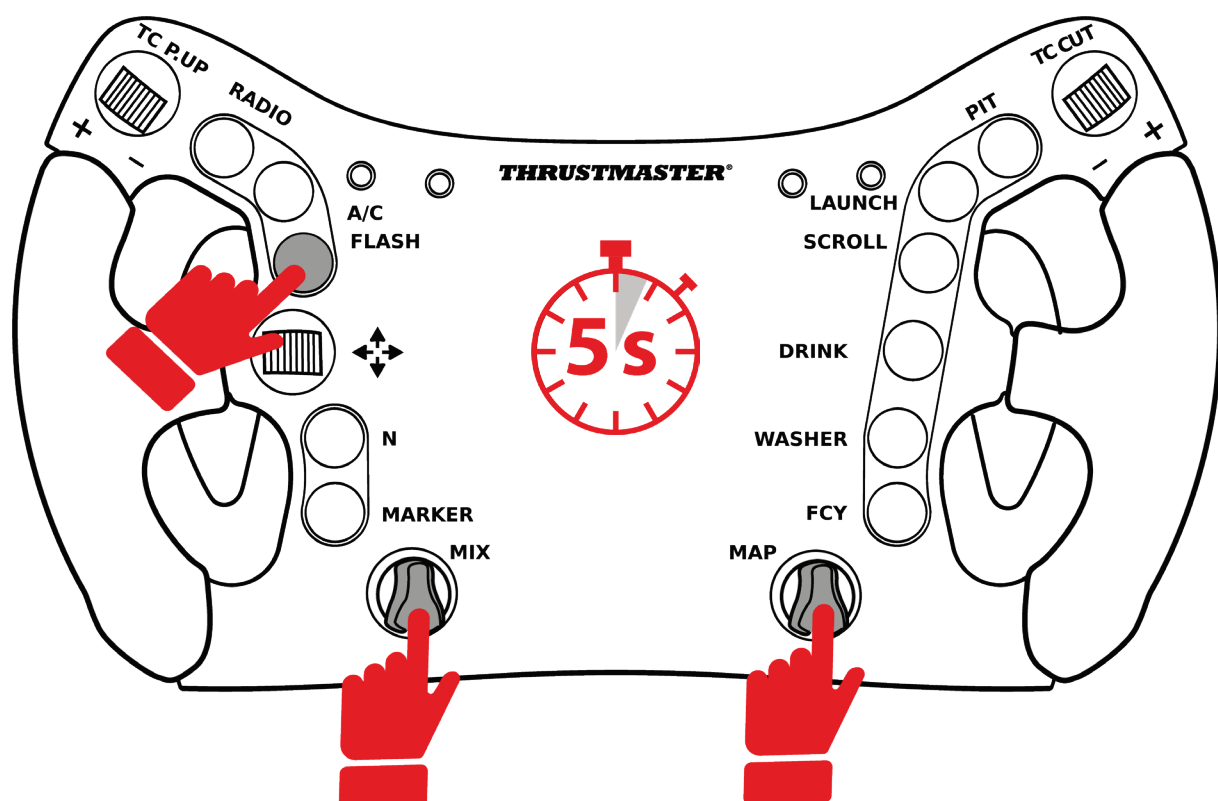

- A LED menübe való belépéshez nyomja meg egyszerre a **FLASH** gombot és mindkét **forgókapcsolót 5 másodpercig**, majd engedje el őket.

- A LED menüből való kilépéshez nyomja meg egyszerre a **FLASH** gombot és mindkét **forgókapcsolót**, majd engedje el őket.



FLAG

RPM

PIT



Belépés a LED menübe: a FLAG és a PIT LED-ek, valamint a fordulatszám LED-ek egyike (piros a bal oldalon, vagy kék a jobb oldalon) világít.



Kilépés a LED menüből: mind a négy LED kialszik.



A LED erősség beállítása

- Lépjen be a LED menübe a **FLASH** gomb és mindkét **forgókapcsoló** 5 másodpercig történő egyidejű lenyomásával, majd engedje el őket.
- Fordítsa a **bal oldali kapcsolót (MIX)** balra az intenzitás csökkentéséhez, vagy jobbra az intenzitás növeléséhez.



- Lépjen ki a LED menüből a **FLASH** gomb és mindkét **forgókapcsoló** egyidejű megnyomásával, majd engedje el őket.



A LED mód megváltoztatása: GT3 vagy Formula

- Lépjen be a LED menübe a **FLASH** gomb és mindkét **forgókapcsoló** egyidejű **5 másodpercig** történő lenyomásával, majd engedje el őket.
- Fordítsa a **jobb oldali kapcsolót (MAP)** balra a GT3 mód kiválasztásához (piros LED), vagy jobbra a Formula mód kiválasztásához (kék LED).



GT3 mód (alapértelmezett mód)



FORMULA mód

- Lépjen ki a LED menüből a **FLASH** gomb és mindkét **forgókapcsoló** egyidejű megnyomásával, majd engedje el őket.



7. A kormányváltók testre szabása

A **Ferrari 488 GT3 Wheel Add-On** kormányváltók távolsága és elérési távolsága állítható.

A **távolságállítás** a kormányváltó szélességének beállításából áll, ami módosítja a markolat és a kormányváltó közötti távolságot.

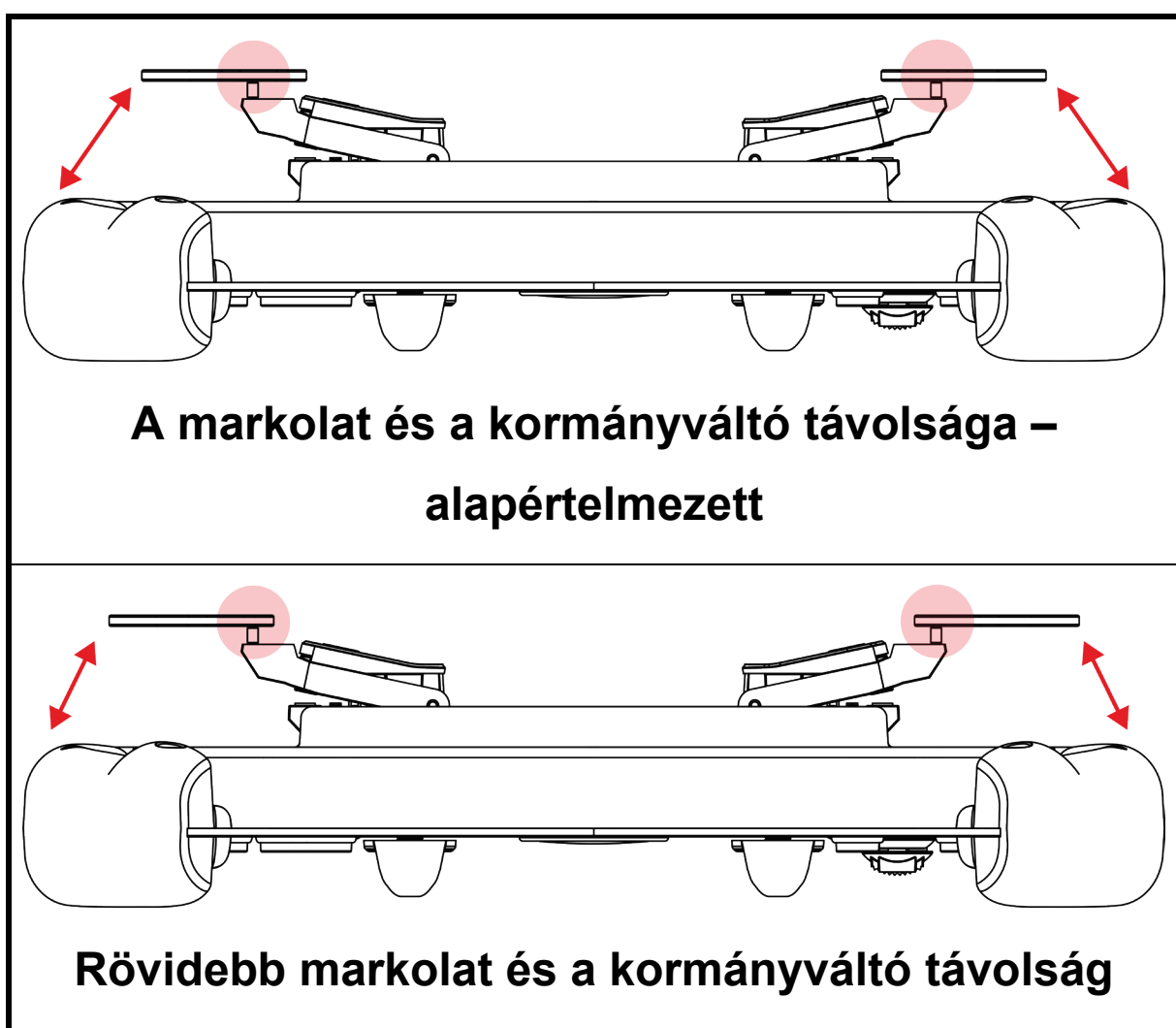



Az **elérésítávolság** beállítása a távtartók segítségével módosítja a kormányváltó aktiválási távolságát.

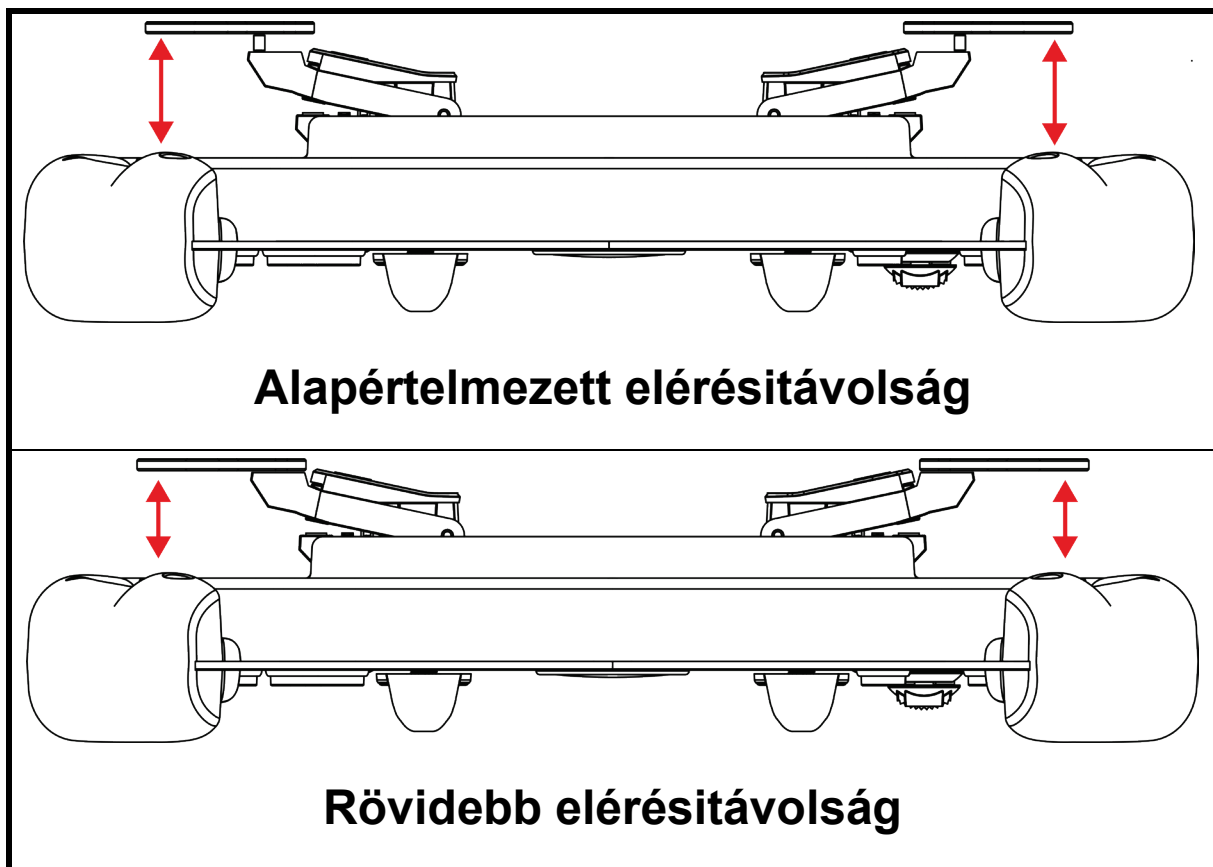

Lehetőség van a **mágneses érzékenység** és a kormányváltók által generált **hangerő** beállítására is a mellékelt alátétkészlet segítségével.

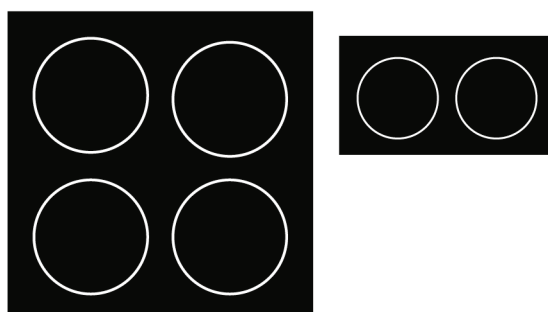



A kormányváltó távolság beállítása

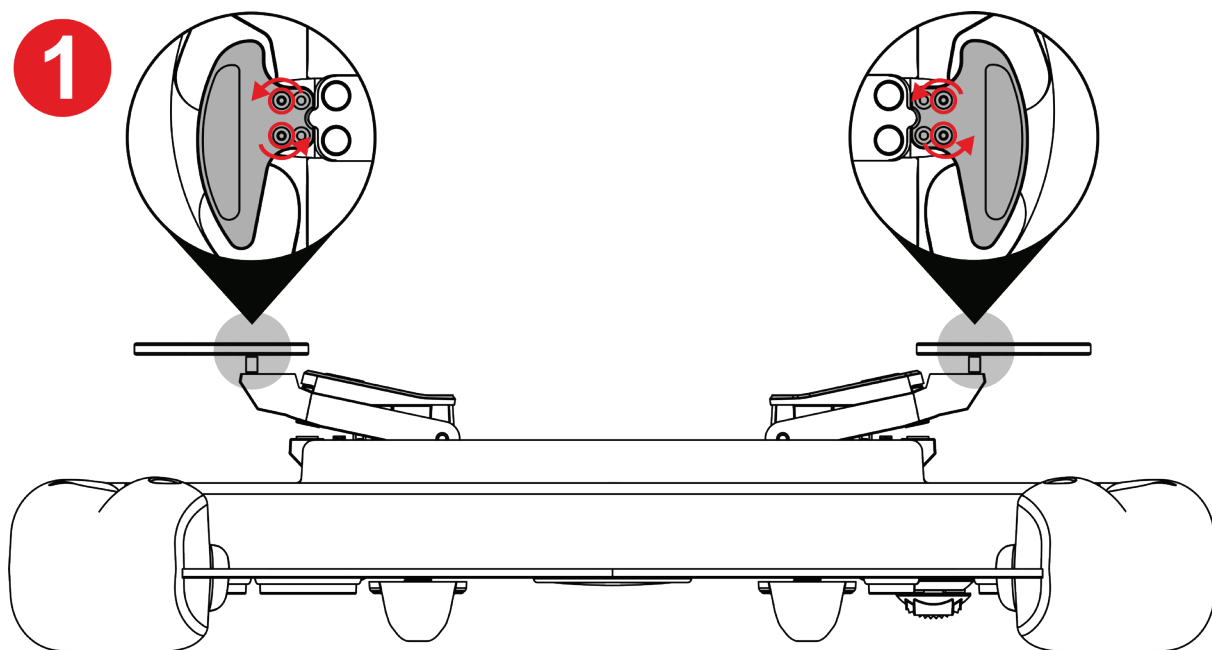

1 Csavarja ki a négy kormányváltó csavart a mellékelt Torx kulccsal.

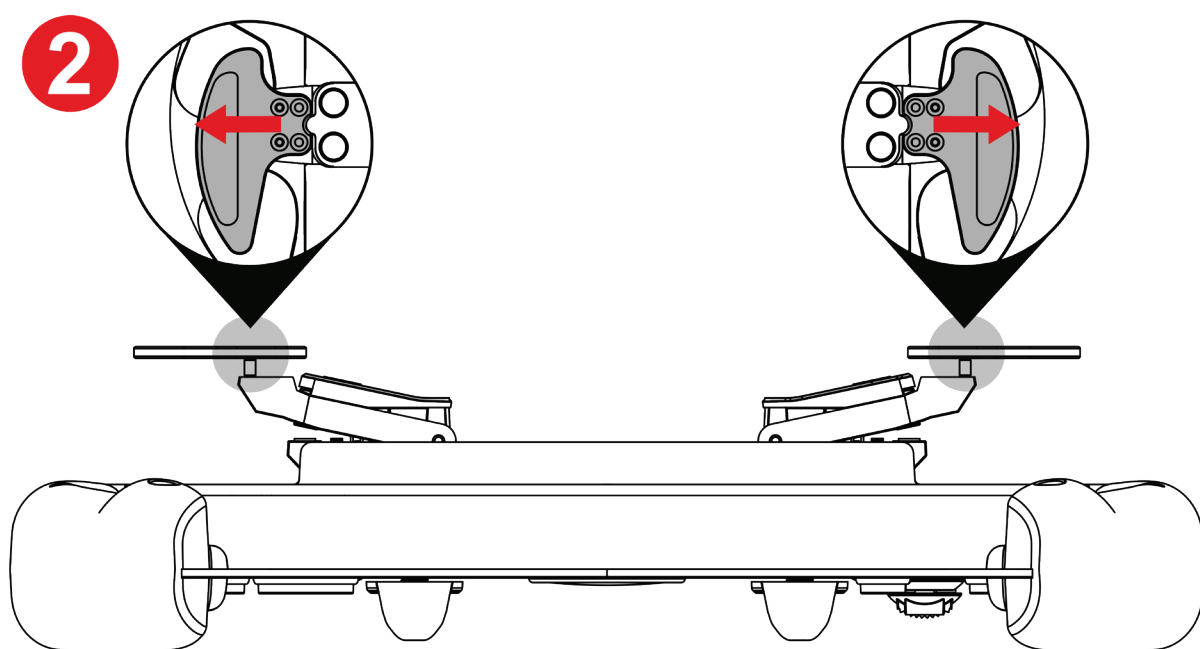

2 Tolja a kormányváltókat kifelé, hogy a lyukakhoz illeszkedjenek.

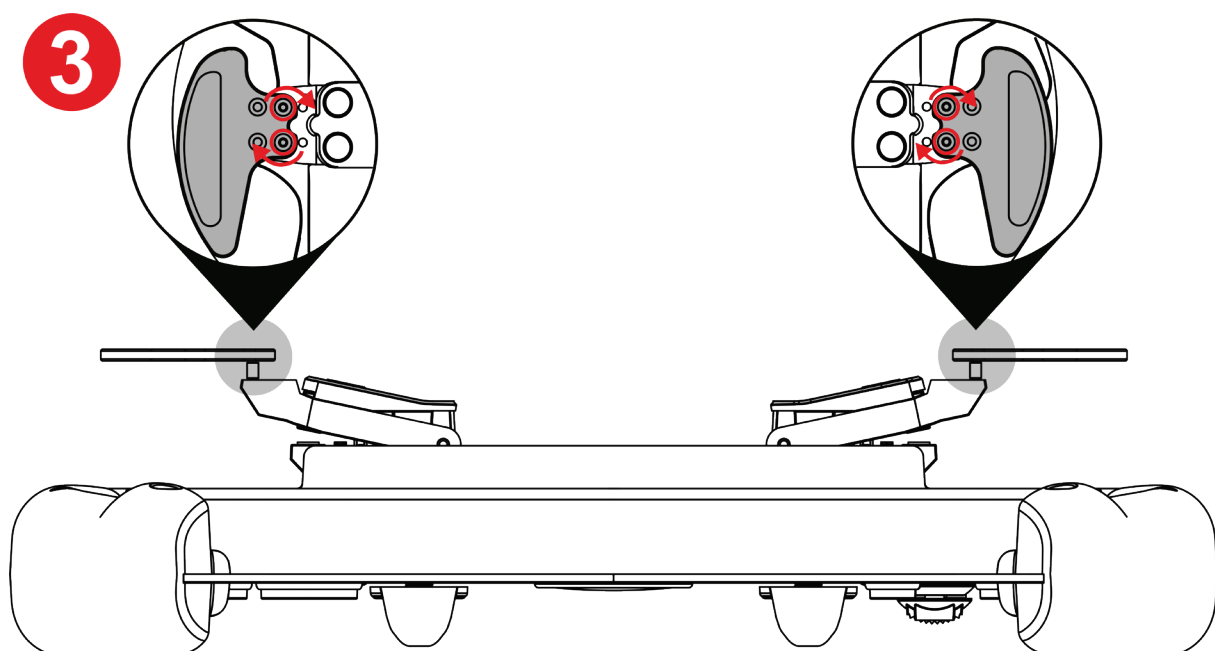

3 Húzza meg a négy kormányváltó csavart a mellékelt Torx kulcs segítségével.



A kormányváltók elérésitávolságának beállítása

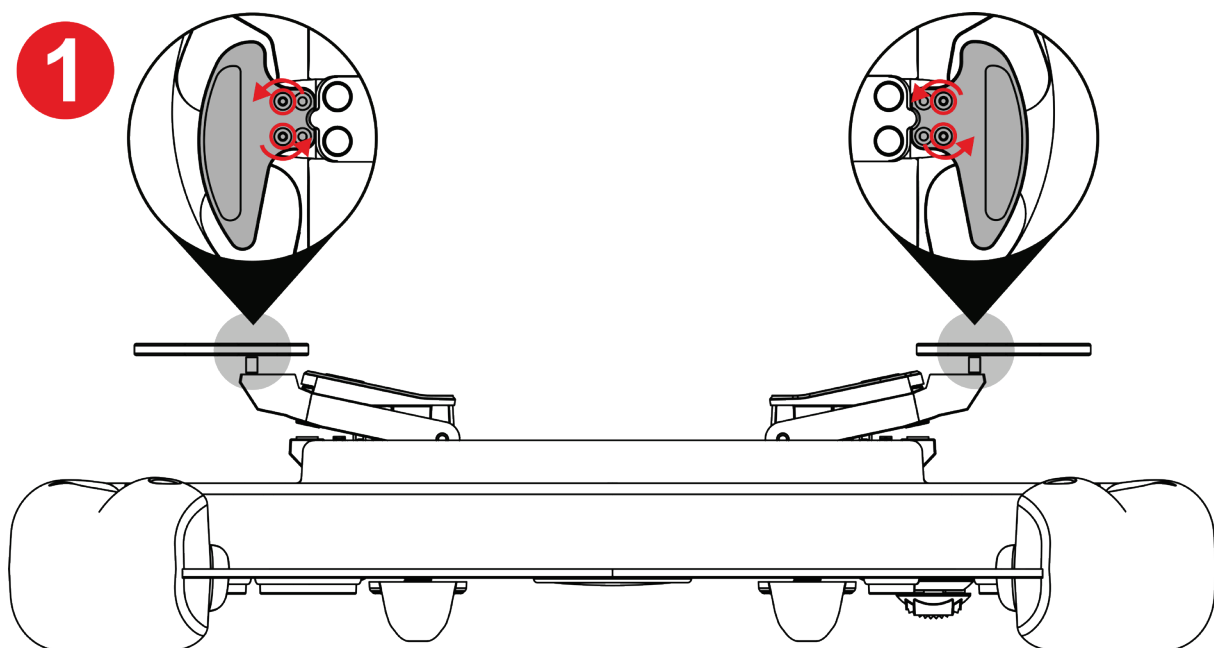

1 Csavarja ki a négy kormányváltó csavart a mellékelt Torx kulccsal.

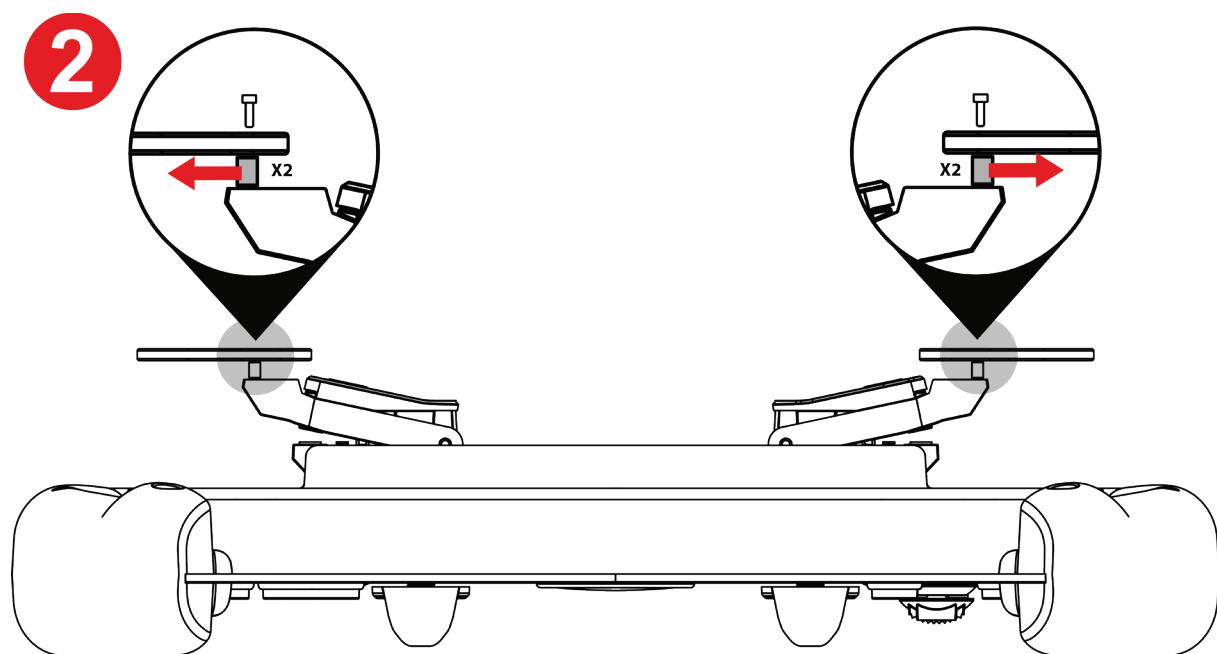

2 Távolítsa el a távtartókat.

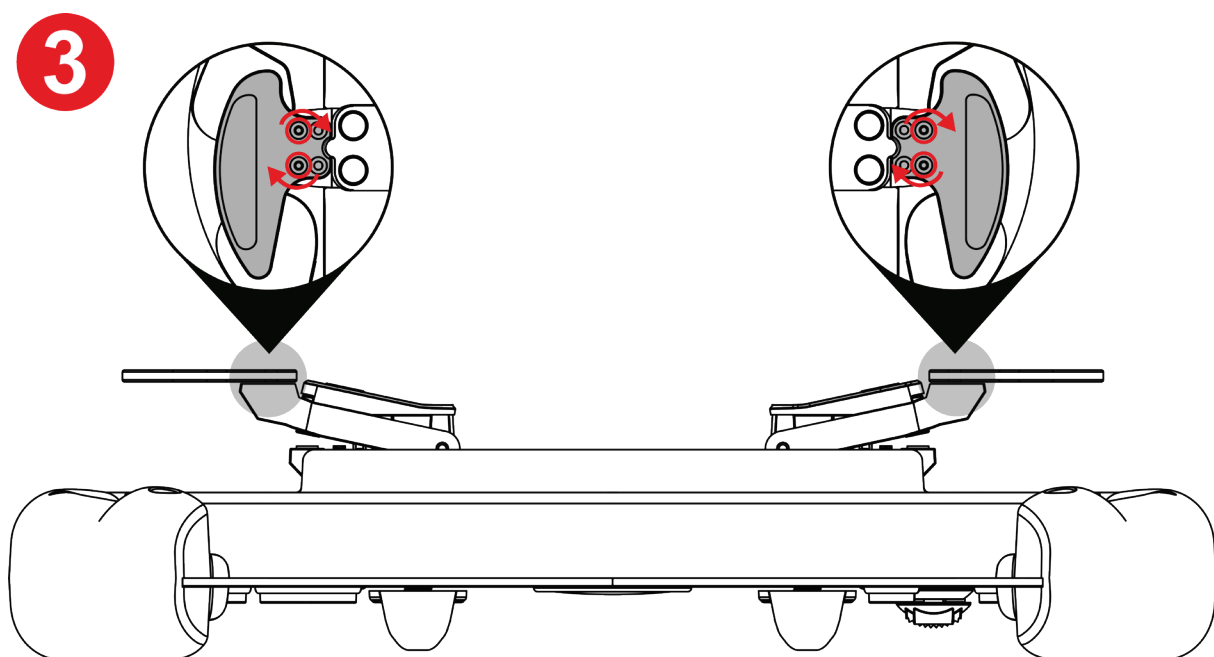

3 Húzza meg a négy kormányváltó csavart a mellékelt Torx kulccsal.



A mágneses érzékenység és a kormányváltók hangszintjének beállítása

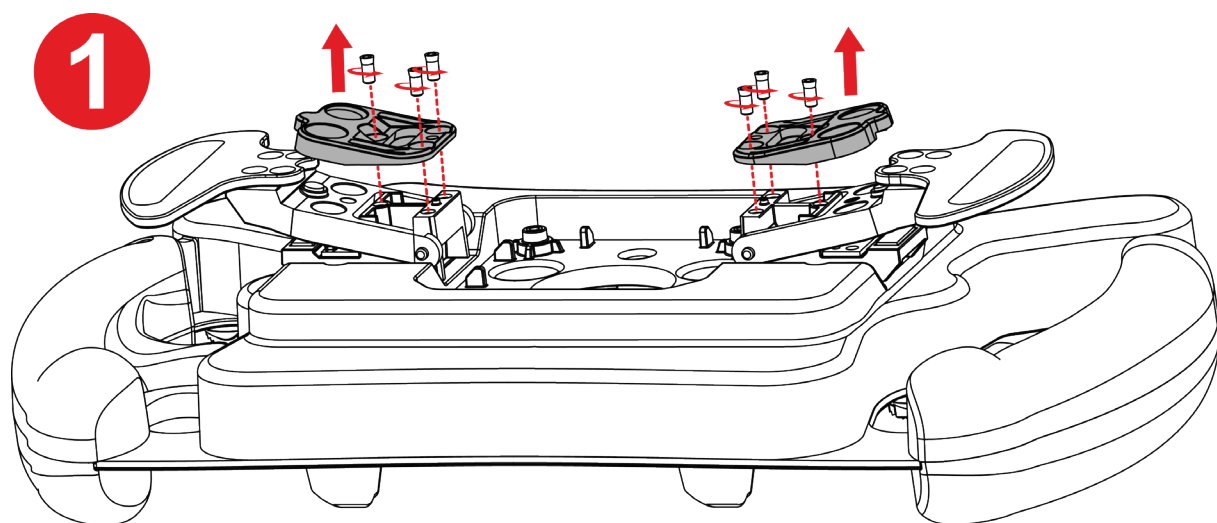

1 Távolítsa el a mágneses ütközőket a hat ütközőcsavar kicsavarásával a mellékelt Torx kulccsal.

2

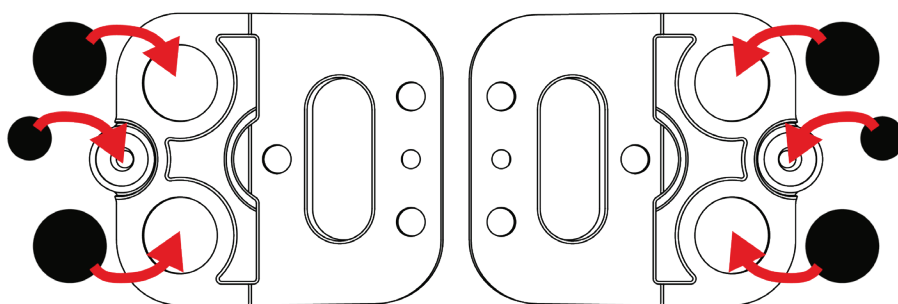
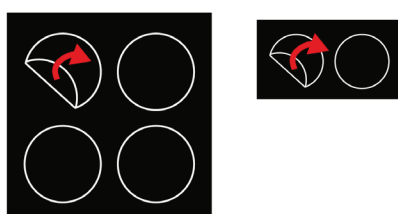

2 Húzza le a mellékelt alátéteket, és rögzítse őket a megfelelő helyeken a mágneses ütközők alatt.



Lehetséges beállításokért és azok hatásaiért olvassa el a **Mágneses érzékenység és kormányváltó hangcsillapítási táblázat** részt.





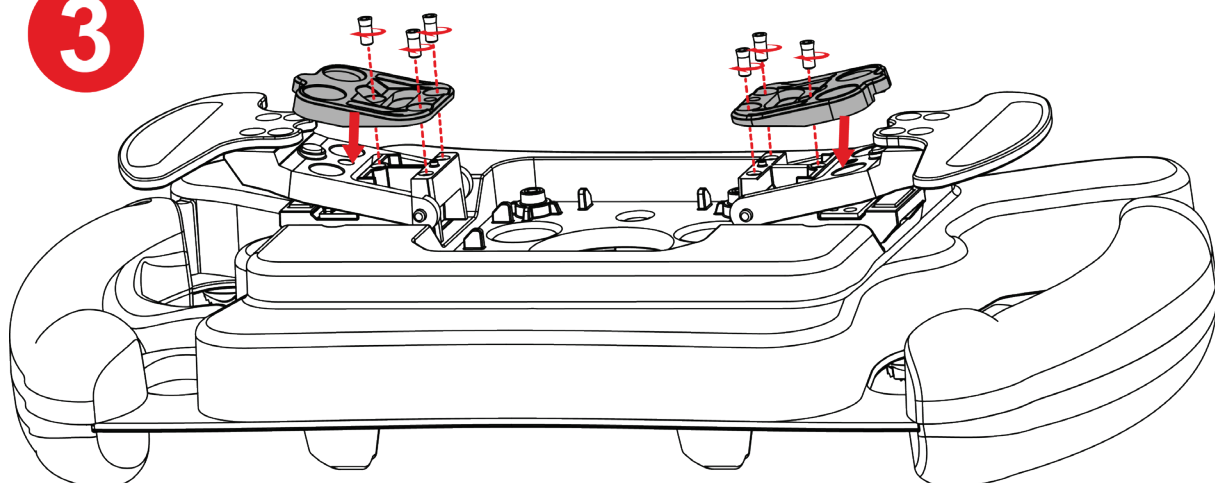

3

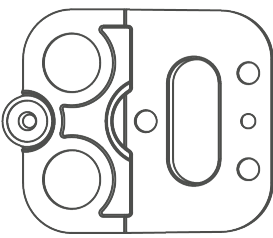
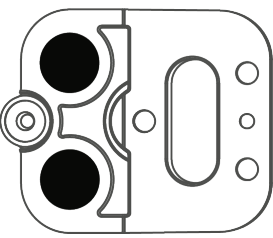
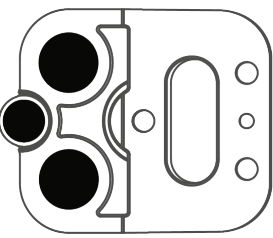

3 Szerelje vissza a mágneses ütközőket, és húzza meg a hat ütközőcsavart a mellékelt Torx kulccsal.

Mágneses érzékenység és kormányváltó hangcsillapítási táblázat

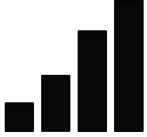
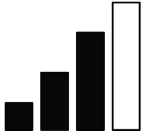
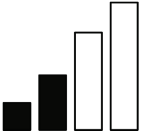
	 (alapértelme- zett)		
Mágneses érzékenység			
Hang			



8. GYIK és technikai támogatás

Kérdése van a Ferrari 488 GT3 Wheel Add On-al kapcsolatban, vagy technikai problémái vannak? Ha igen, látogasson el a Thrustmaster műszaki támogatás weboldalára:

<https://support.thrustmaster.com/product/ferrarif488gt3addon>.

Ezen az oldalon frissítheti a kormány firmware-jét is.



THRUSTMASTER®



FERRARI 488 GT3 WHEEL ADD-ON



(Windows 10/11) PC

PS5™ / PS4™

Xbox One / Xbox Series

מדריך למשתמש



יש לקרוא בתשומת לב את ההוראות שבמדריך זה לפני התקנת המוצר, לפני השימוש בו ולפני כל פעולת תחזוקה. יש להקפיד לפעול בהתאם להנחיות הבטיחות. אי הקפדה על הנחיות אלו עלולה לגרום לתאונות ו/או לנזק. יש לשמור את המדריך לשימוש חוזר בעתיד.

תוכן העניינים

5.....	תכולת האריזה	1.
	6 תכונות	2.
8.....	מידע לגבי השימוש בהגה	3.
13.....	התקנת מחזיק השחרור המהיר	4.
14.....	התקנה של מחזיק שחרור מהיר לבסיס תפס	
17.....	התקנה של מחזיק שחרור מהיר לבסיס בורג	
	21 מיפוי	5.
21.....	מיפוי ל-PC	
22.....	מיפוי עבור PS5™ / PS4™	
23.....	מיפוי עבור Xbox One / Xbox Series	
	24 פעולת LED	6.
25.....	כיצד להיכנס/לצאת מתפריט LED	
27.....	כיצד להתאים את עוצמת ה-LED	
28...	כיצד לשנות את מצב LED :GT3 או Formula	

7. התאמה אישית של מוטות העברת

הילוכים 29

כיצד להתאים את הרווח בין מוטות העברת

ההילוכים 31

כיצד להתאים את הטווח של מוטות העברת

ההילוכים 33

כיצד להתאים את הרגישות המגנטית ואת רמת

הצליל של מוטות העברת ההילוכים 35

8. שאלות נפוצות ותמיכה טכנית 37



FERRARI 488 GT3 WHEEL ADD-ON

היו חלק מהאגדה של מרוצי GT עם Ferrari 488 GT3 Wheel Add-On, הגה המיועד לביצועים, וכן תואם לכל בסיסי ההגה של Thrustmaster.

מדריך זה יעזור לכם להתקין את Ferrari 488 GT3 Wheel Add-On ולהשתמש בו בתנאים הטובים ביותר. לפני תחילת המרוצים, חשוב לקרוא בתשומת לב את ההוראות והאזהרות: הן יסייעו להפיק הנאה מירבית מהמוצר.



1. תכולת האריזה

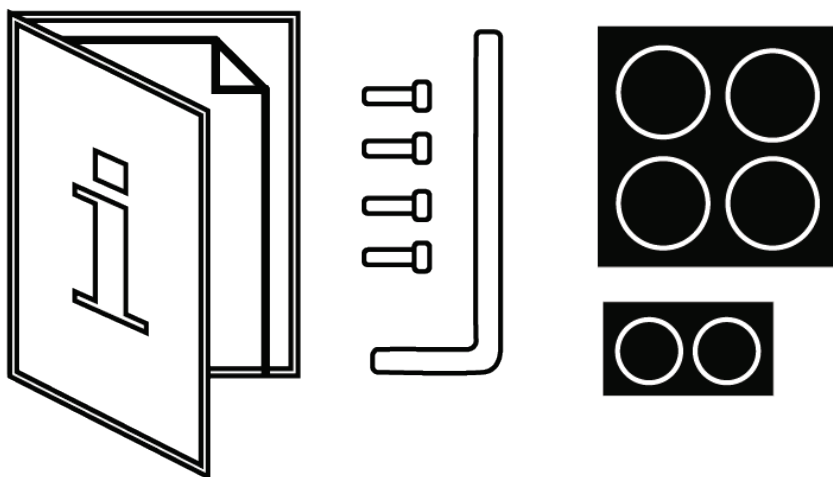
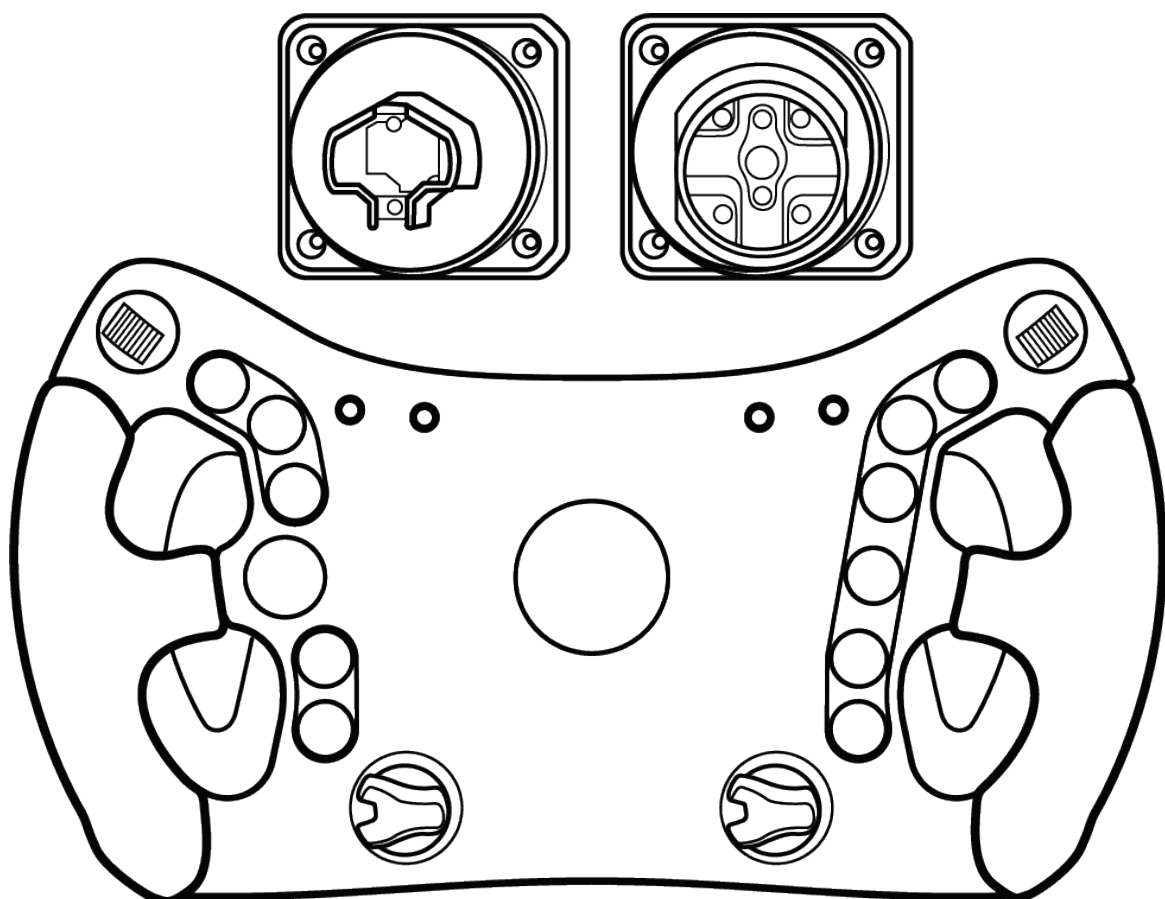



2. תכונות

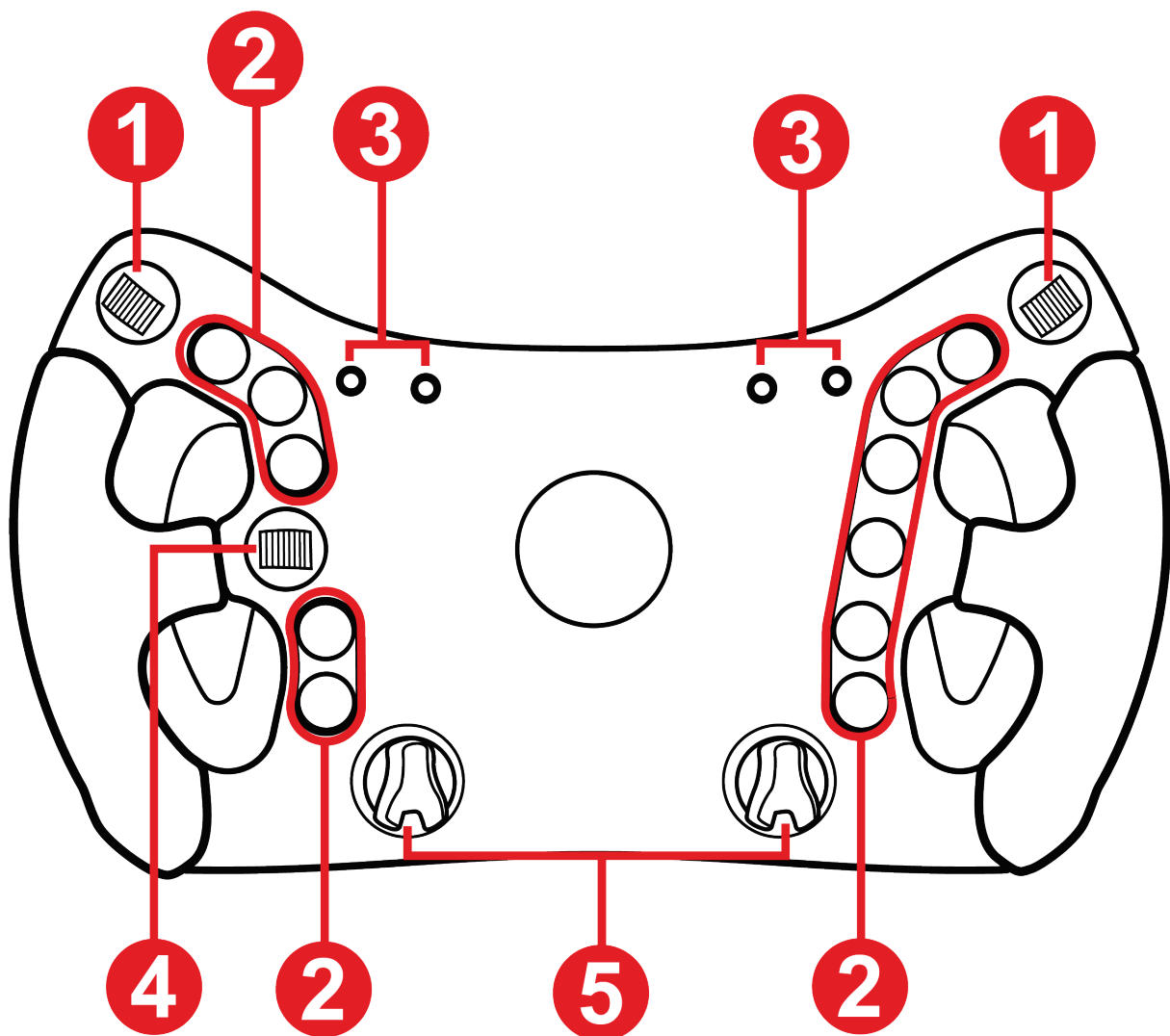

① מקודדי אגודל

② 11 לחצני פעולות

③ נוריות LED ל-RPM ולנתוני מרוץ (דגלים, עצירות

תחזוקה)

④ D-pad

⑤ מקודדים סיבוביים

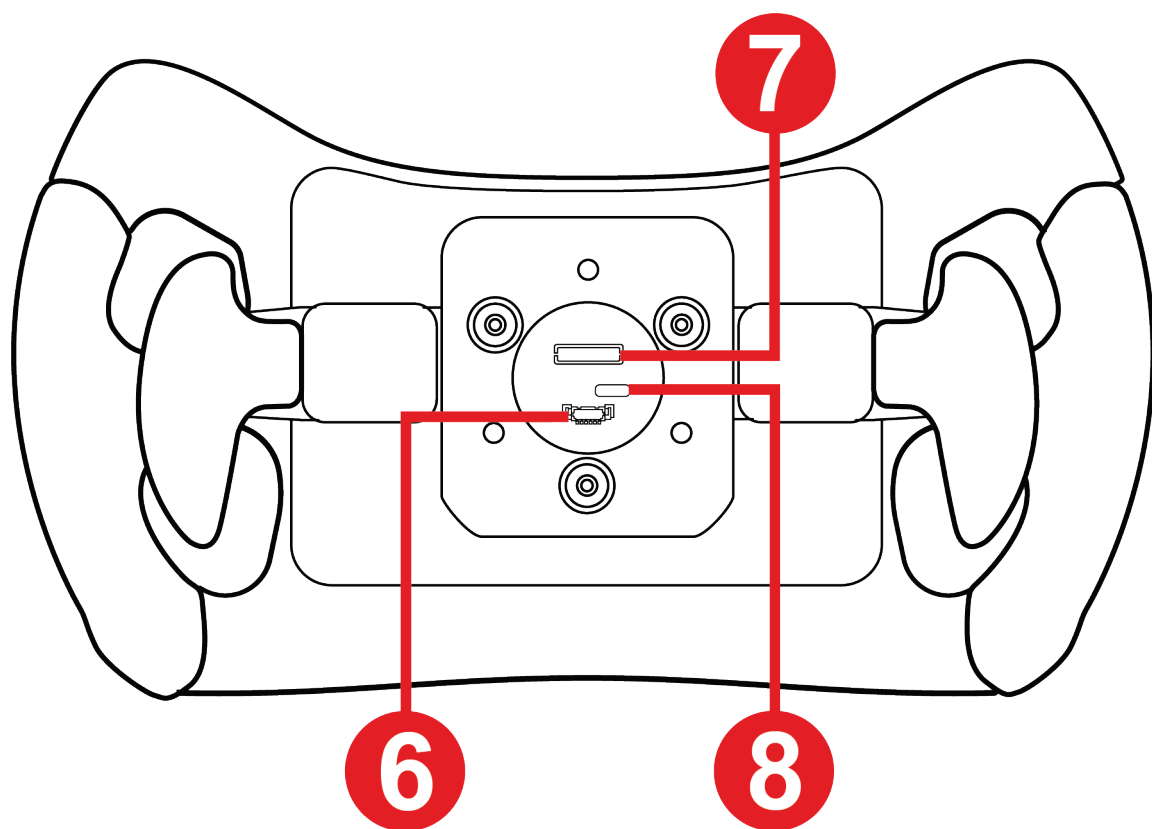

⑥ יציאת חיבור עבור מחזיק שחרור מהיר לבסיס בורג

⑦ יציאת חיבור עבור מחזיק שחרור מהיר לבסיס תפס

⑧ יציאת USB-C (אם נדרש עדכון קושחה – כבל לא כלול)

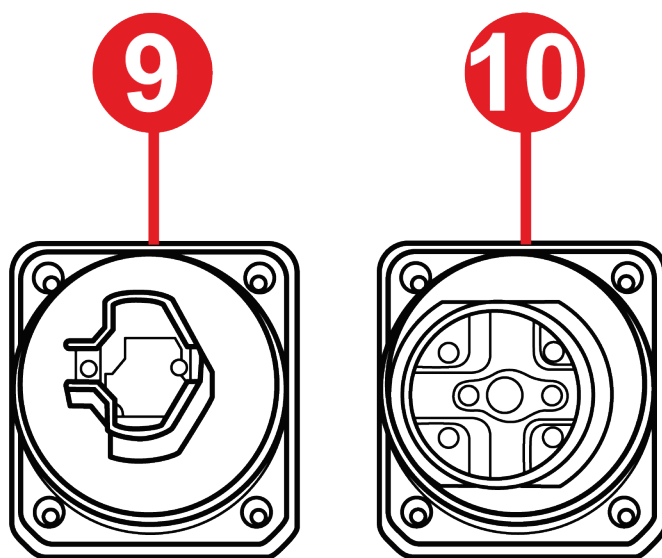

⑨ מחזיק שחרור מהיר לבסיס תפס

⑩ מחזיק שחרור מהיר לבסיס בורג



3. מידע לגבי השימוש בהגה



מסמך הפעלה

לפני השימוש במוצר, יש לקרוא מסמך זה שוב בתשומת לב, ולשמור אותו לשימוש נוסף בעתיד.



התחשמות

- יש לשמור את המוצר במקום יבש ולהימנע מחשיפתו לאבק או לאור שמש.
- אין לפתל או למשוך את המחברים והכבלים.
- יש לעקוב אחר הוראות החיבור.
- אין לשפוך נוזלים על המוצר או על המחברים שלו.
- אין לגרום לקצר במוצר.
- אין לפרק את המוצר (אלא אם מדובר בהתאמה אישית המפורטת במדריך זה); אין לזרוק אותו לאש ואין לחשוף אותו לטמפרטורות גבוהות.
- אין לפתוח את המכשיר: הוא אינו מכיל חלקים המיועדים לטיפול על ידי המשתמש. כל התיקונים חייבים להתבצע על ידי היצרן, נציג מורשה או טכנאי מוסמך.



בטיחות באזור המשחק

- אין להציב באזור המשחק חפצים שעלולים להפריע לשימוש בהגה, או שעלולים לגרום לתנועות או להפרעות מצד אדם אחר (לדוגמה כוס קפה, טלפון, מפתחות).

- אין לכסות את כבלי החשמל בשטיח, במרבד, בשמיכה או בכל דבר דומה, ואין להניח את הכבלים במקום שבו אנשים עוברים.



פציעות עקב היזון חוזר ותנועות חוזרות ונשנות

השימוש בהגה מרוצים עם היזון חוזר עלול לגרום לכאבי שרירים או מפרקים. כדי למנוע בעיות אפשריות:

- יש לבצע פעילות גופנית קלה לחימום לפני השימוש ולהימנע משימוש למשך פרקי זמן ארוכים ברצף.

- יש להקפיד על הפסקות של 10 עד 15 דקות לאחר כל שעת שימוש.

- אם מופיעות תחושות של עייפות או כאבים בידיים, במפרקים, בזרועות או ברגליים, יש ללחוץ על הלחצן כדי לכבות את ההיזון החוזר, לכבות את הבסיס ולנוח כמה שעות לפני שימוש נוסף.

- אם התסמינים או הכאב שצוינו לעיל ממשיכים בשימוש הבא שלאחר ההפסקה, יש לחדול מהשימוש ולפנות לרופא.

- אין להגדיר רמה גבוהה מדי של היזון חוזר שלא מתאימה לרמת המומחיות והמצב הגופני של המשתמש.

- יש להרחיק את המכשיר מהישג ידם של אנשים מתחת לגיל 16.

- יש לוודא שההגה והבסיס מחוברים היטב בהתאם להוראות שבמדריך זה.



סכנה בעת סיבובים מהירים, חזקים ולא צפויים: אין להכניס את היד או הזרוע לפתחים שבגלגל ההגה, או במקום שאליו ההגה צפוי להגיע בסיבוב.

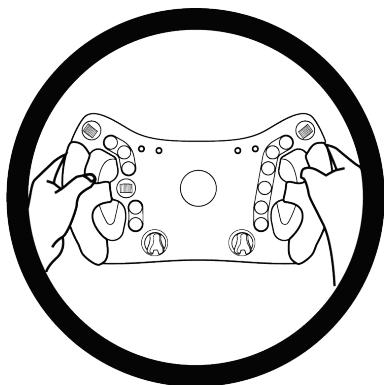

בעת השימוש במוצר, תמיד יש לאחוז בהגה באמצעות שתי הידיים במקום המתאים ואף פעם אסור לשחרר אותו לגמרי.



המוצר מיועד למשתמשים מגיל 16 ומעלה בלבד.



4. התקנת מחזיק השחרור המהיר

Ferrari 488 GT3 Wheel Add-On מלווה בשני מחזיקי שחרור מהיר התואמים לפורמטים הבסיסיים של Thrustmaster.

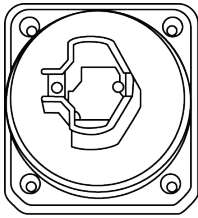
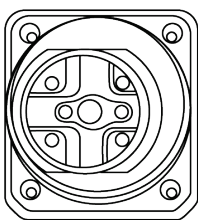
מערכת	תאימות
 <p>מחזיק שחרור מהיר לבסיס תפס</p>	T818 Ferrari SF1000 ,T818 Thrustmaster Simulator ובסיסי עתידיים.
 <p>מחזיק שחרור מהיר לבסיס בורג</p>	T300 ,T-GT II Servo Base / T-GT ,TS PC Racer ,RS Servo Base TX Racing Wheel Servo ,TS-XW .TS-XW Servo Base ,Base



לפני כל שימוש, יש לוודא ש **Ferrari 488 GT3 Wheel Add-On** עדיין מחוברת כראוי לתמיכה, בהתאם להוראות המדריך לבסיס.



התקנה של מחזיק שחרור מהיר לבסיס תפס

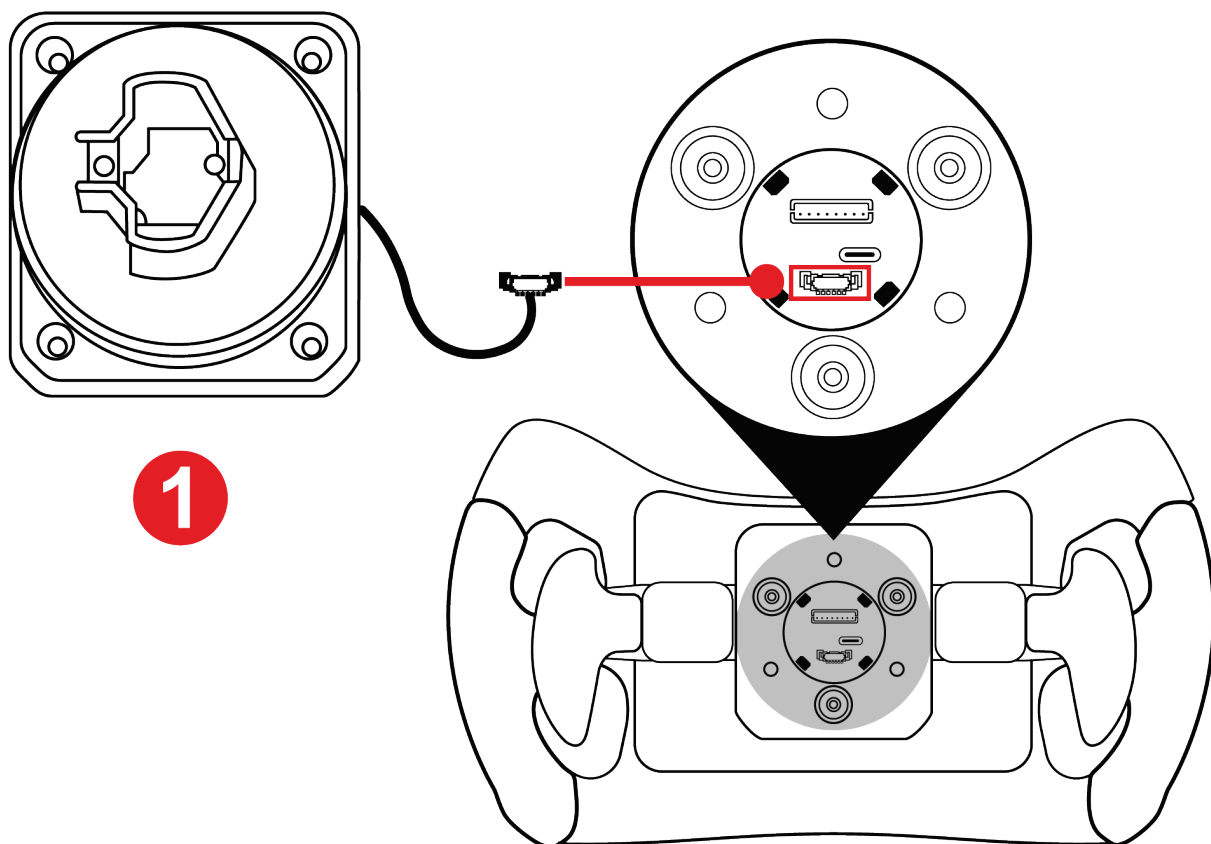

1 יש לחבר את מחבר מחזיק השחרור המהיר ליציאה המתאימה בגב ההגה.



כדי למנוע צביטה של הכבל, יש להחזיר אותו אל תוך התא שלו לפני הברגת המחזיק.

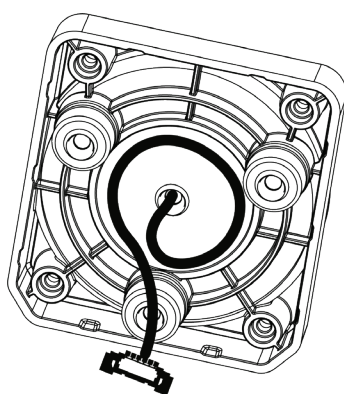

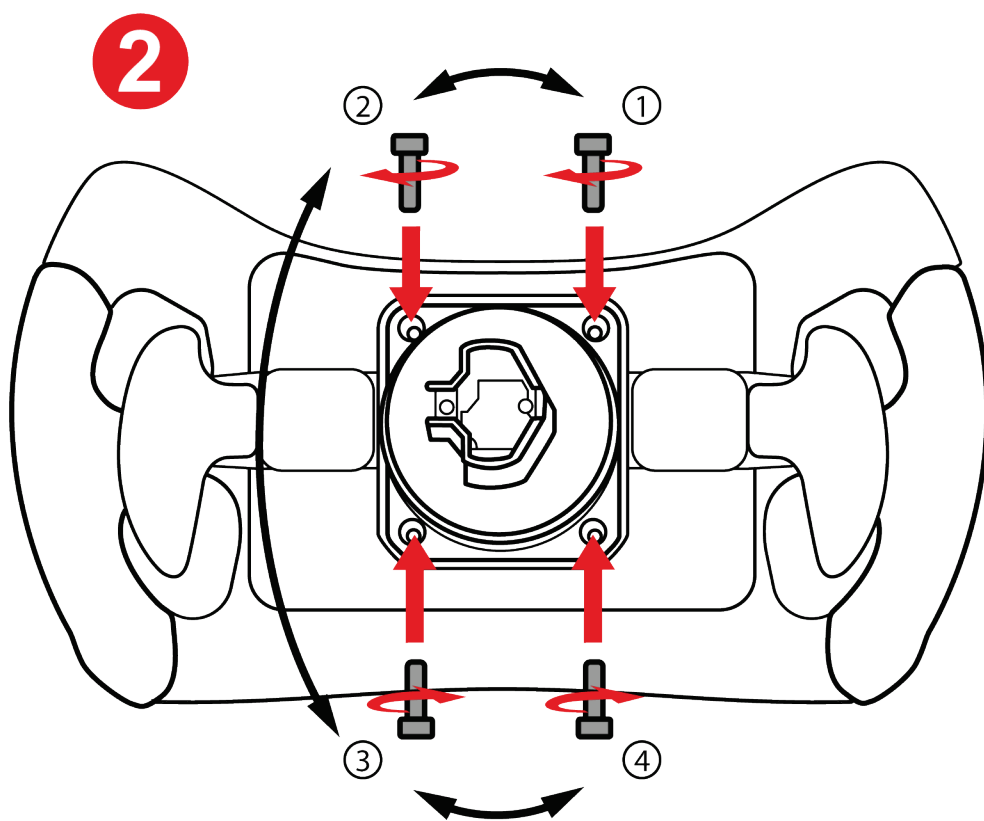

② יש להכניס את מחזיק השחרור המהיר ולהדק אותו באמצעות מפתח הטורקס המצורף.



בעת הרכבת המחזיק, אין להדק את הברגים יתר על המידה.

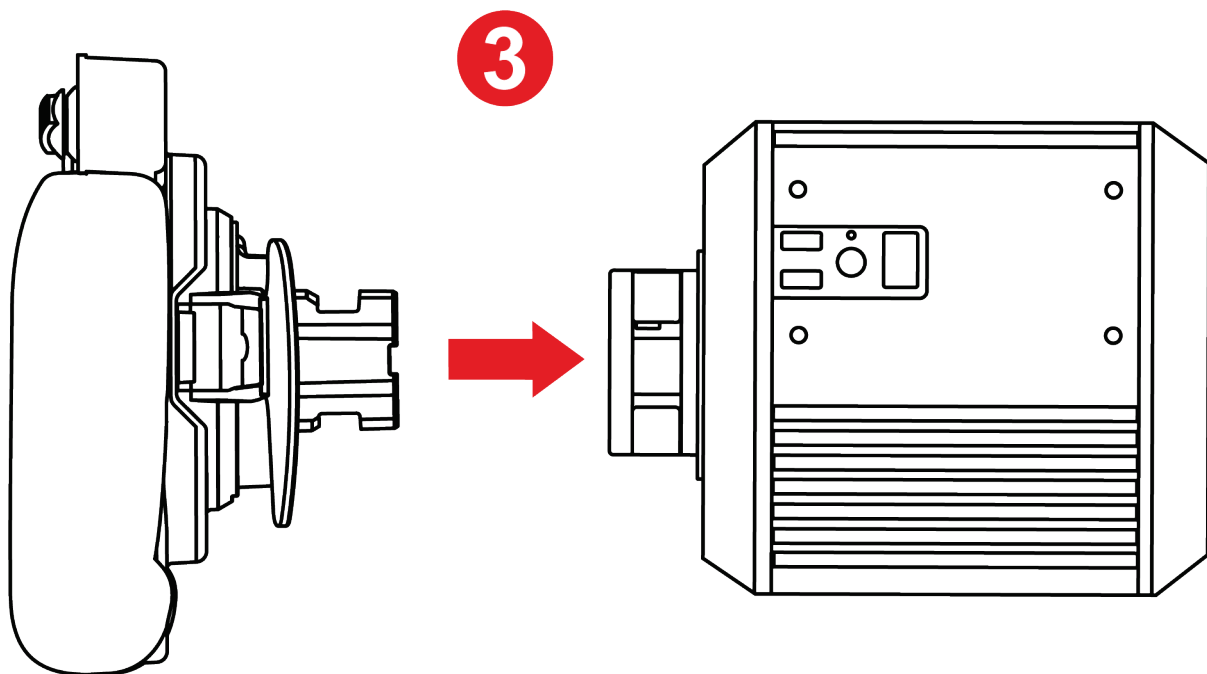

3 יש להתקין את ההגה על הבסיס.



יש לבצע את ההתקנה בהתאם להליך המפורט במדריך למשתמש של הבסיס.



התקנה של מחזיק שחרור מהיר לבסיס בורג

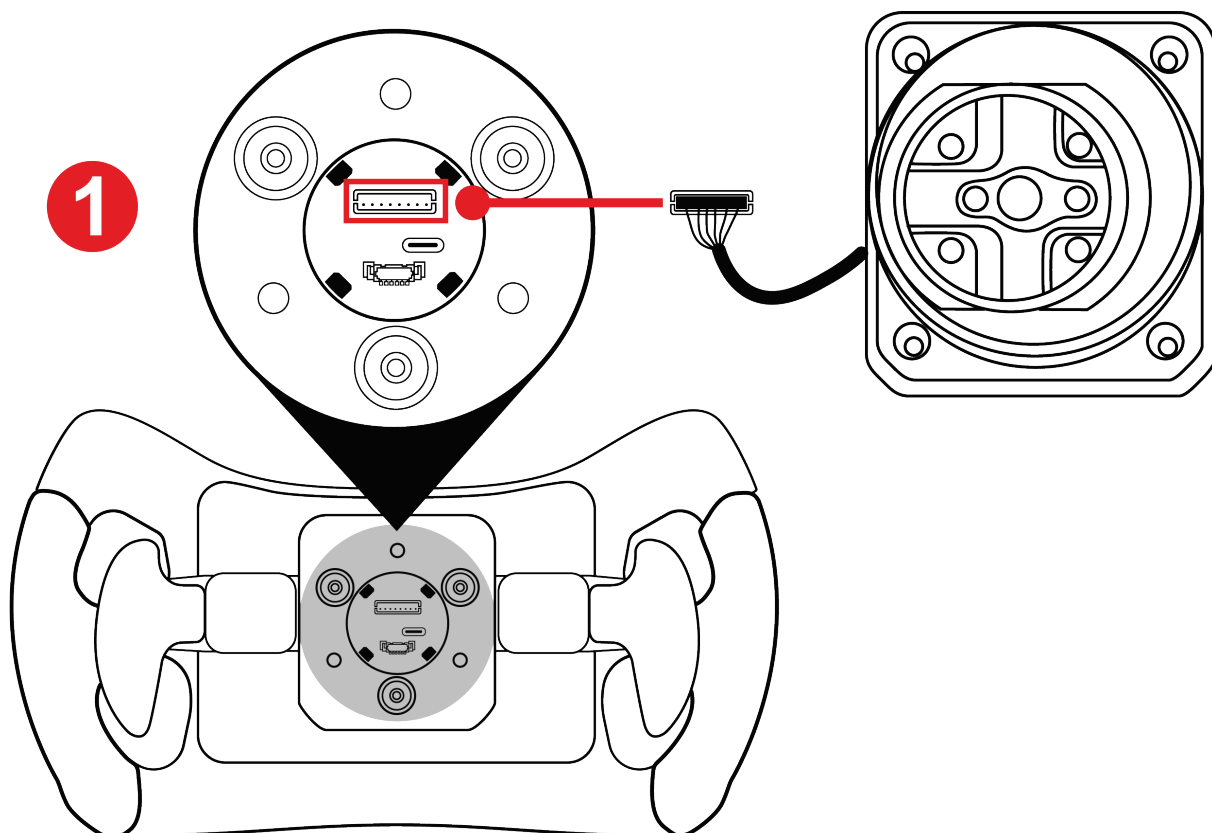

1 יש לחבר את מחבר מחזיק השחרור המהיר ליציאה המתאימה בגב ההגה.



כדי למנוע צביטה של הכבל, יש להחזיר אותו אל תוך התא שלו לפני הברגת המחזיק.

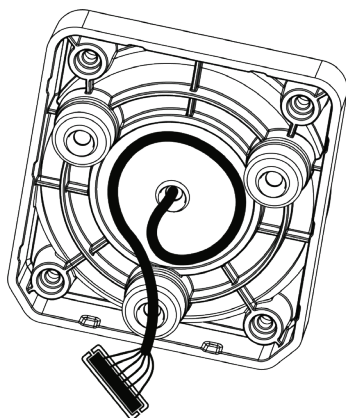

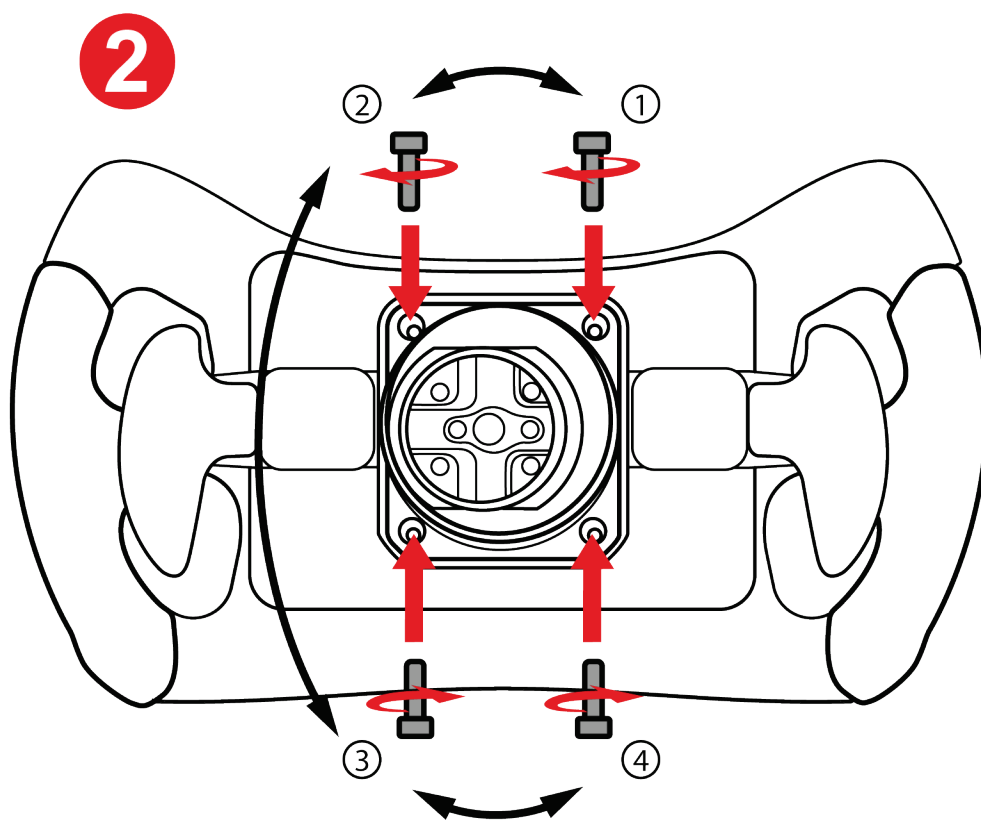

② יש להכניס את מחזיק השחרור המהיר ולהדק אותו באמצעות מפתח הטורקס המצורף.



בעת הרכבת המחזיק, אין להדק את הברגים יתר על המידה.

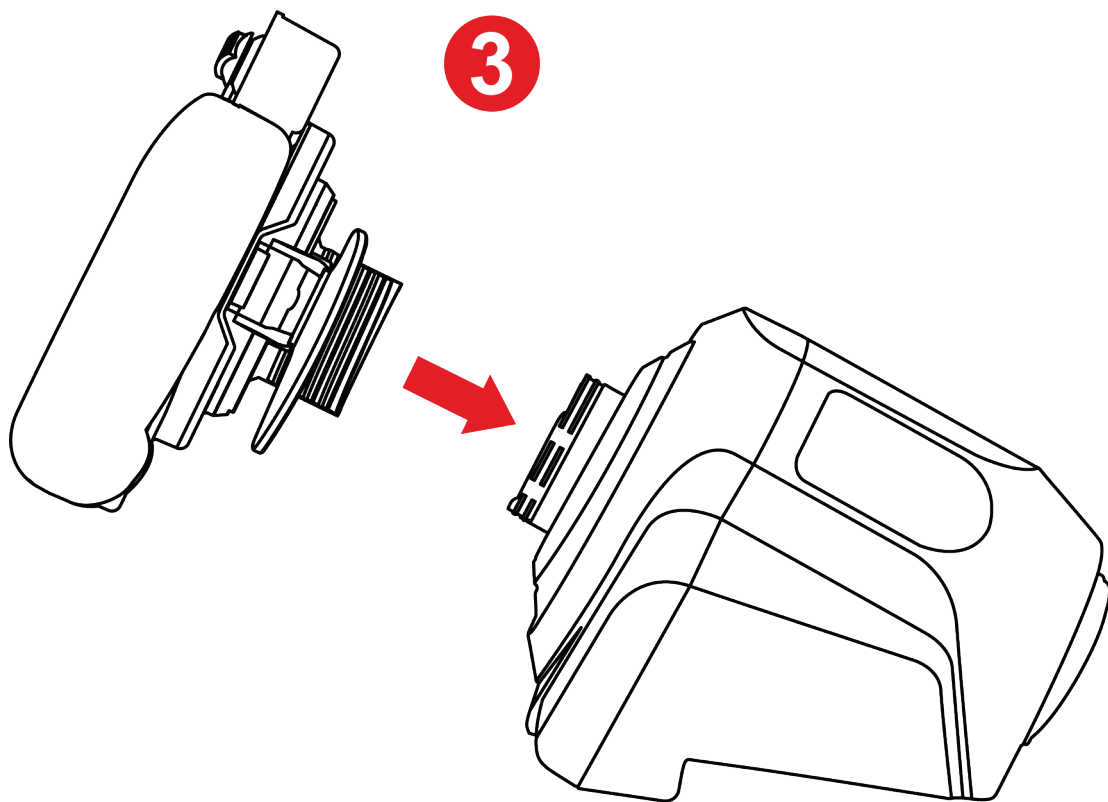

3 יש להתקין את ההגה על הבסיס.



יש לבצע את ההתקנה בהתאם להליך המפורט במדריך למשתמש של הבסיס.



לעולם אין לחבר את מתאם השחרור המהיר (מצורף לבסיס ה-T818 ונמכר בנפרד) למגן השחרור המהיר עבור בסיס הבורג, אם בכוונתך להשתמש בו על בסיס T818.

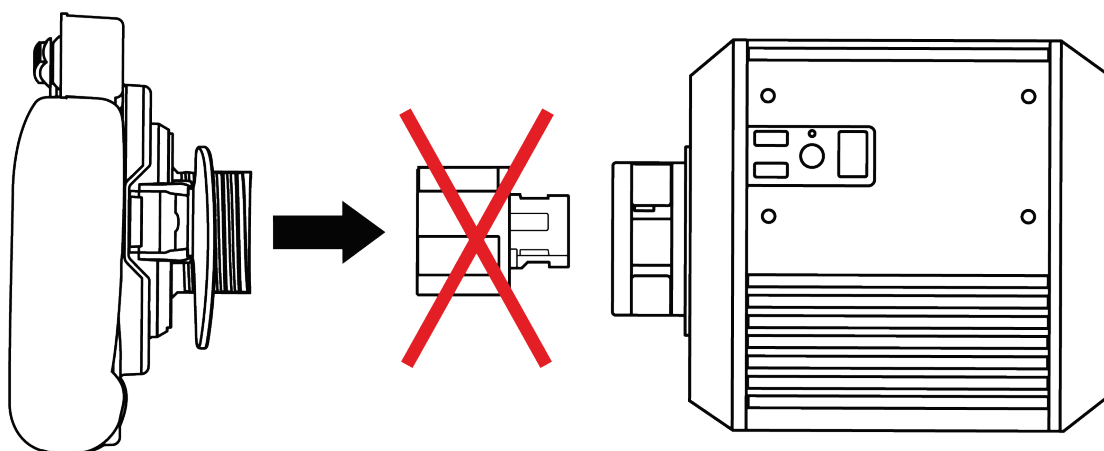
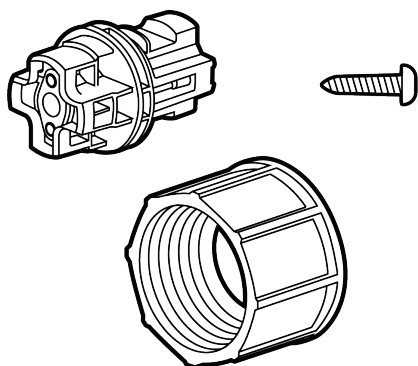

לשימוש על בסיס T818 או בסיס מצויד במחבר לבסיס תפס, יש להשתמש רק במחזיק השחרור המהיר לבסיס התפס המצורף ל-Ferrari 488 GT3 Wheel Add-On.



5. מיפוי

מיפוי ל-PC

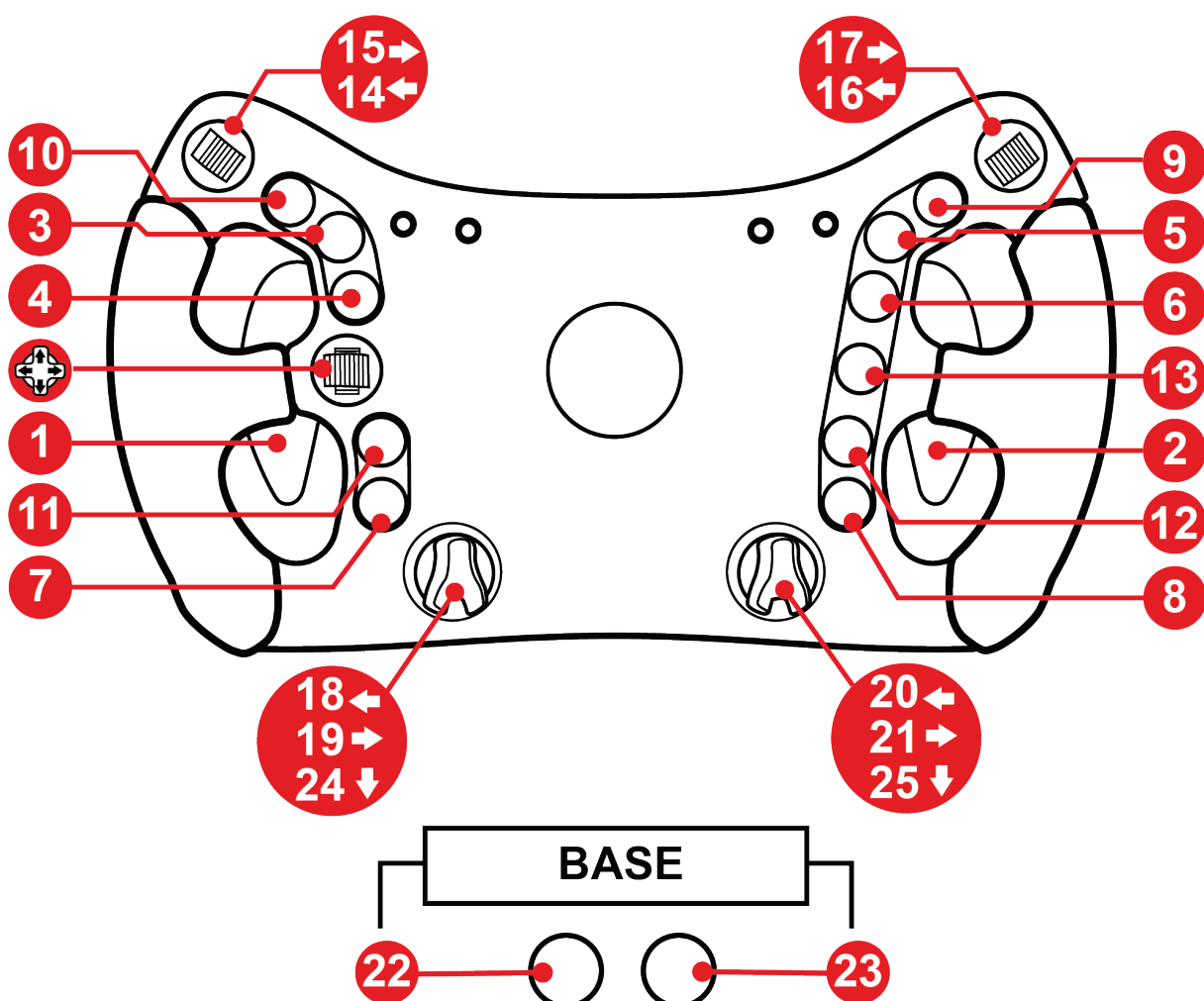



מיפוי עבור PS5™ / PS4™

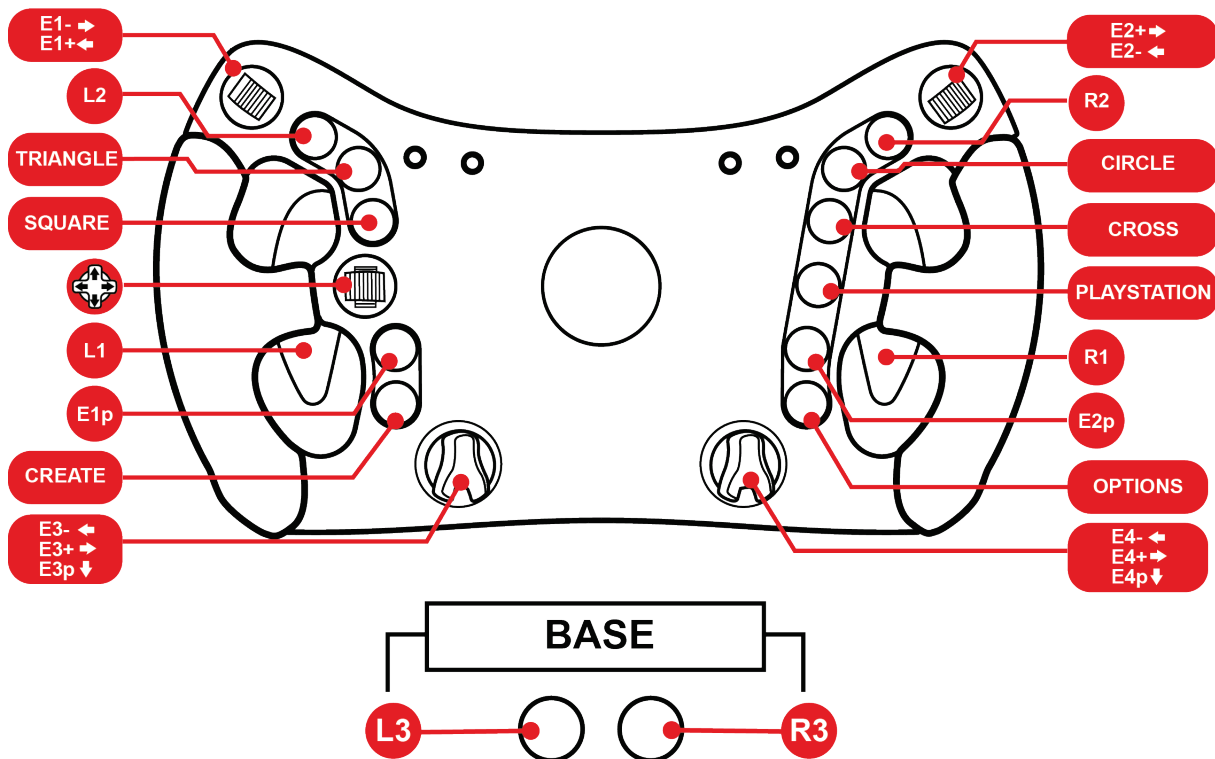



מיפוי עבור Xbox One / Xbox Series

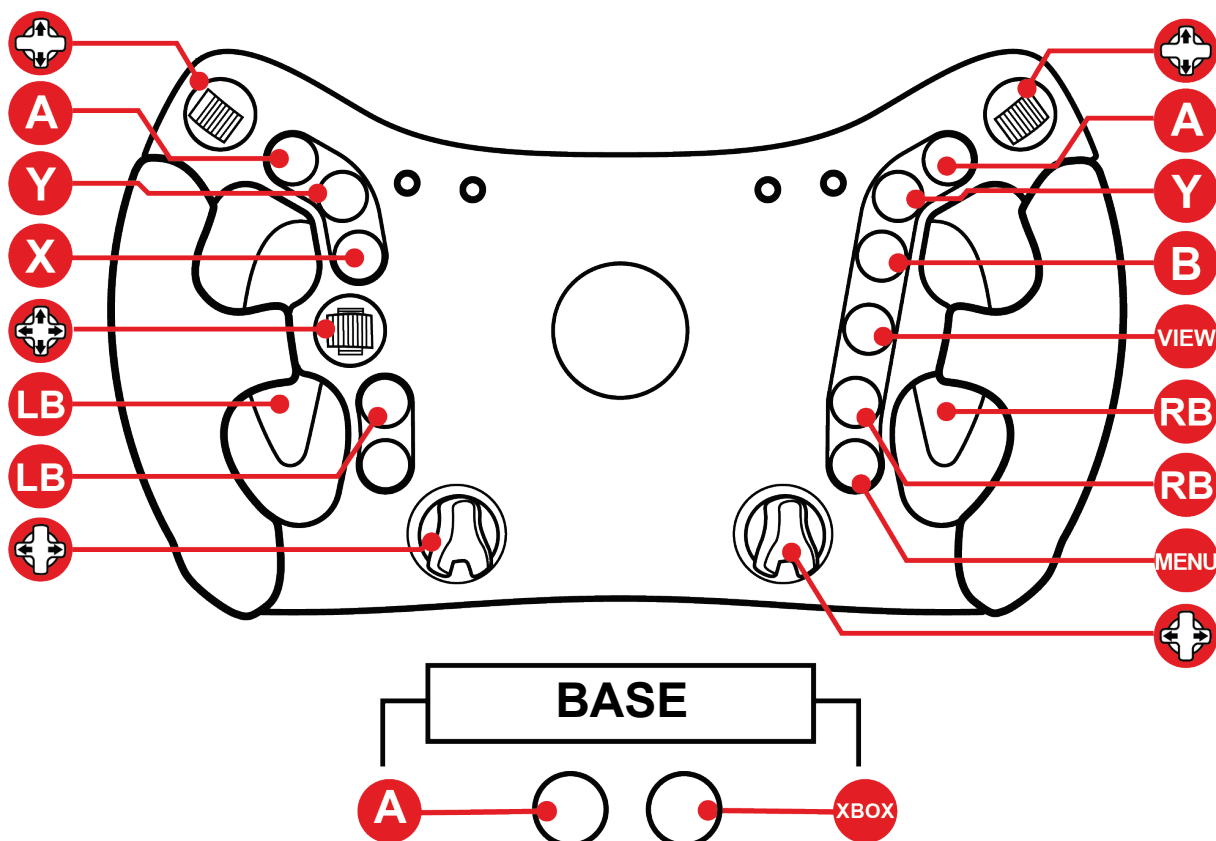

ב-Xbox One וב-Xbox Series:

- נוריות ה-LED ב-Ferrari 488 GT3 Wheel Add-On אינן פונקציונליות עקב הגבלות פרוטוקול הקונסולה.
- חלק מהפונקציות (מקודדים, מספר לחצנים) מוגבלות על ידי פרוטוקול הקונסולה.

6. פעולת LED

Ferrari 488 GT3 Wheel Add-On מציג נתוני מרוץ באמצעות נוריות ה-LED: דגל, עצירות תחזוקה וסל"ד. ניתן להתאים את הנתונים המוצגים (עוצמה וצבע של נוריות ה-LED של הסל"ד), בהתאם למצב (GT3 או Formula).

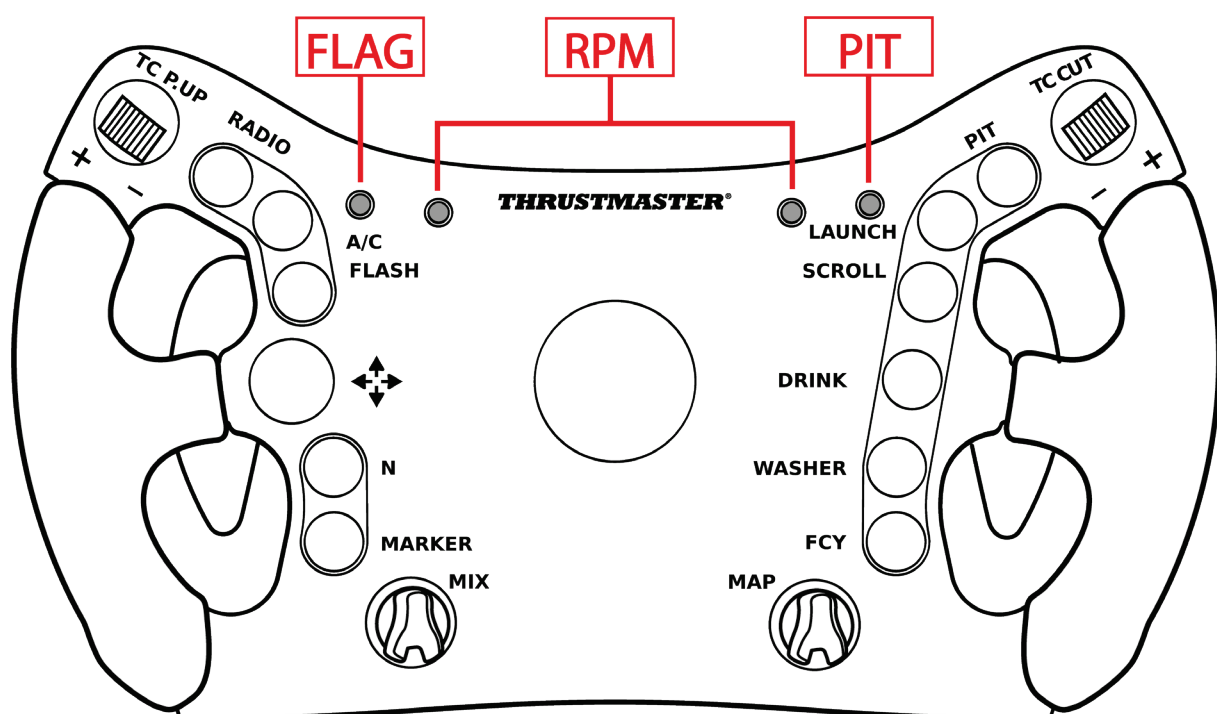

נוריות ה-LED פונקציונליות ב-PC וב-PS4™ / PS5™. נוריות ה-LED אינן פונקציונליות עקב הגבלות פרוטוקול הקונסולה ב-Xbox Series וב-Xbox One.



כיצד להיכנס/לצאת מתפריט LED

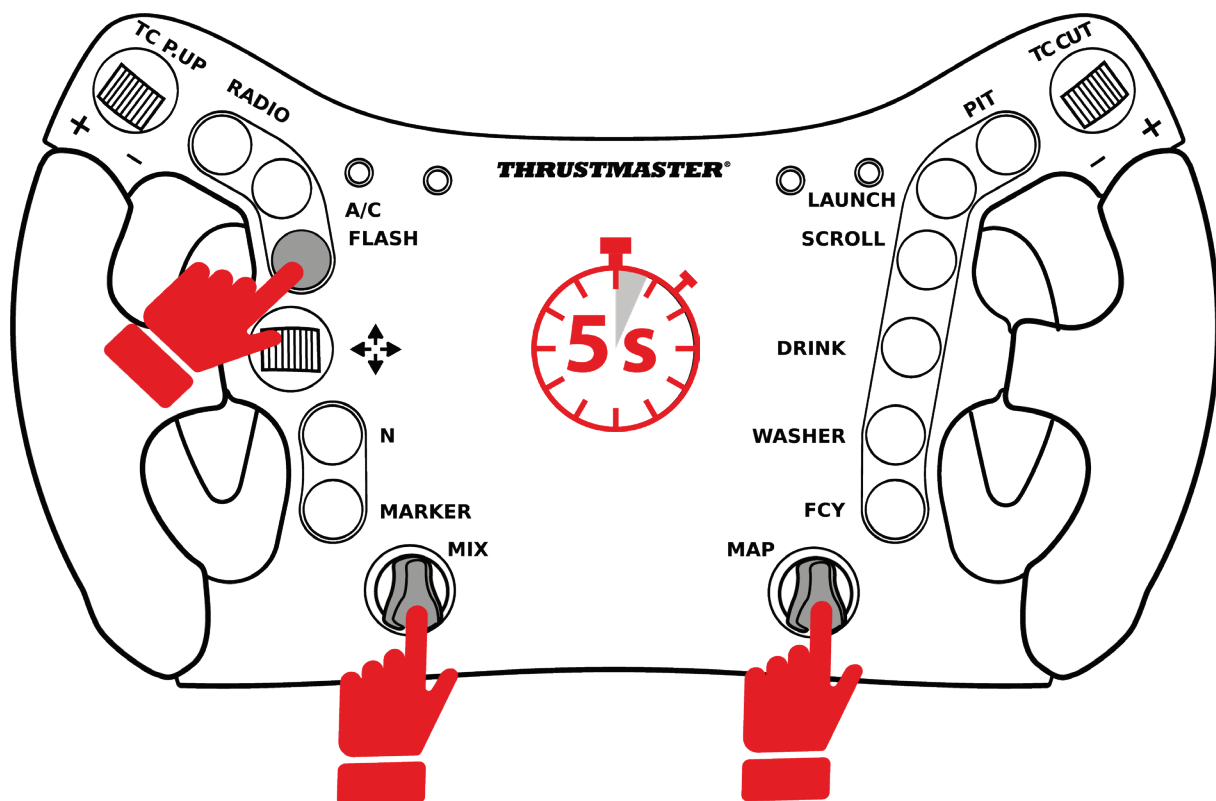

- כדי להיכנס לתפריט LED, יש ללחוץ בו-זמנית על לחצן FLASH ועל שני המקודדים הסיבוביים למשך 5 שניות, ולאחר מכן לשחרר אותם.

- כדי לצאת מתפריט LED, יש ללחוץ בו-זמנית על לחצן FLASH ועל שני המקודדים הסיבוביים, ולאחר מכן לשחרר אותם.



FLAG

RPM

PIT



היכנסו לתפריט LED: נוריות ה-LED של FLAG וה-PIT ואחת מנורות ה-LED של RPM (אדום משמאל, או כחול מימין) נדלקות.



צאו מתפריט LED: כל ארבע הנוריות נכבות.



כיצד להתאים את עוצמת ה-LED

- יש להיכנס לתפריט LED על ידי לחיצה בו-זמנית על הלחצן FLASH ועל שני המקודדים הסיבוביים למשך 5 שניות, ואז לשחרר אותם.

- יש לסובב את המקודד השמאלי (MIX) שמאלה כדי להפחית את העוצמה, או ימינה כדי להגביר את העוצמה.



- יש לצאת מתפריט LED על ידי לחיצה בו-זמנית על הלחצן FLASH ועל שני המקודדים הסיבוביים, ואז לשחרר אותם.



כיצד לשנות את מצב LED: GT3 או Formula

- יש להיכנס לתפריט LED על ידי לחיצה בו-זמנית על הלחצן FLASH ועל שני המקודדים הסיבוביים למשך 5 שניות, ואז לשחרר אותם.

- יש לסובב את המקודד הימני (MAP) שמאלה כדי לבחור את מצב GT3 (LED אדום), או ימינה כדי לבחור את מצב Formula (LED כחול).



מצב GT3 (מצב ברירת מחדל)



מצב FORMULA

- יש לצאת מתפריט LED על ידי לחיצה בו-זמנית על הלחצן FLASH ועל שני המקודדים הסיבוביים, ואז לשחרר אותם.



7. התאמה אישית של מוטות העברת

הילוכים

הרווח וטווח ההגעה של מוטות העברת ההילוכים של Ferrari 488 GT3 Wheel Add-On ניתנים להתאמה.

הרווח נקבע על ידי התאמת מוט העברת ההילוכים לרוחב, שמשנה את המרחק בין האחיזה למוט העברת ההילוכים.

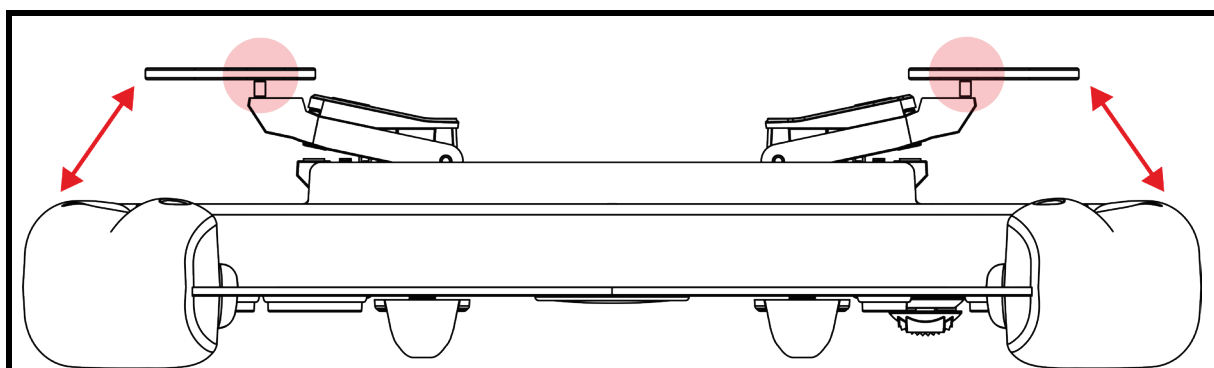

המרחק בין האחיזה למוט העברת ההילוכים - כברירת מחדל

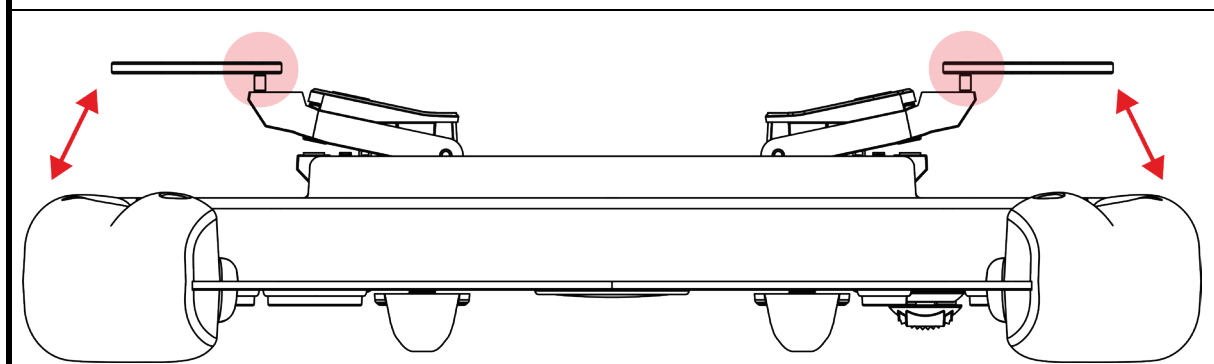

מרחק קטן יותר בין האחיזה למוט העברת ההילוכים



התאמת **טווח ההגעה** באמצעות המרווחים משנה את מרחק
ההפעלה של מוט העברת ההילוכים.

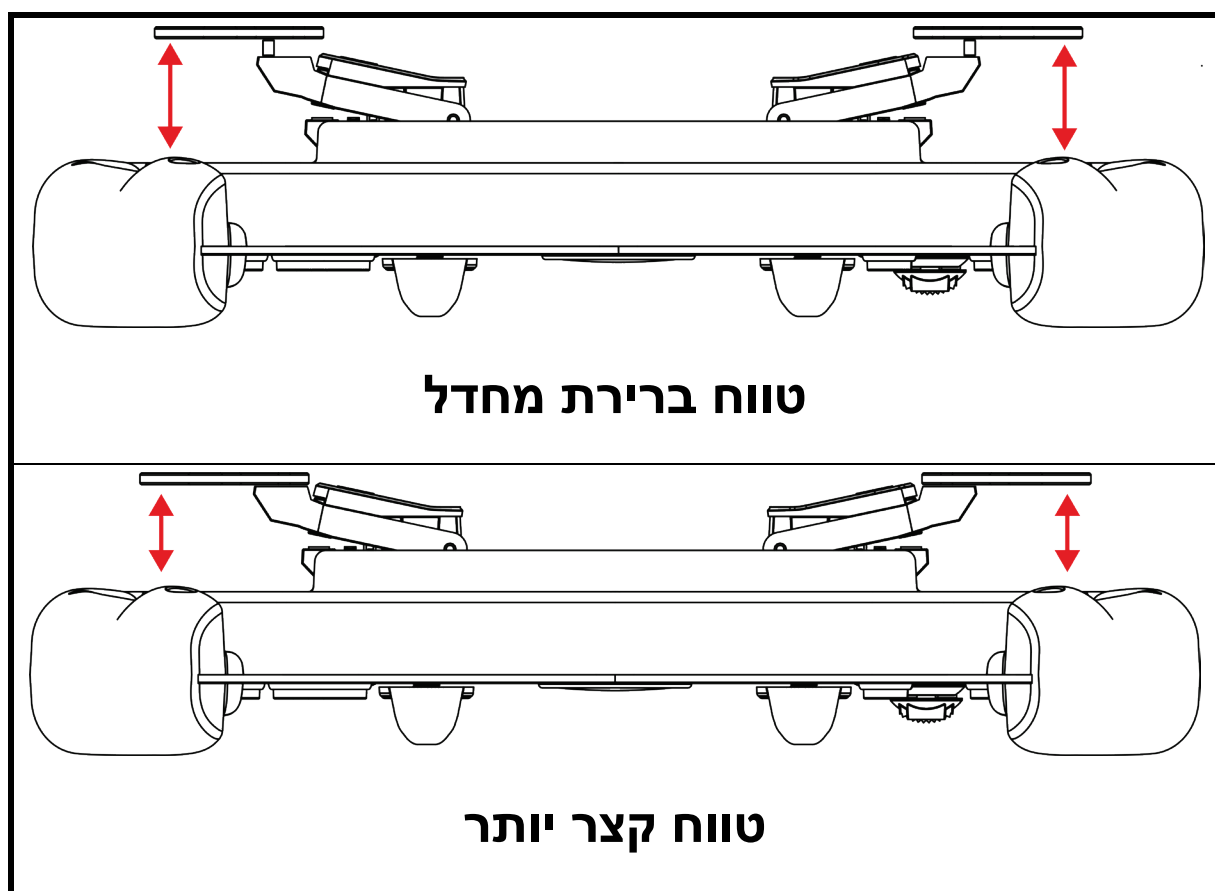

ניתן גם לכוונן את הרגישות המגנטית ואת רמת הצליל
המופקים על ידי מוטות העברת ההילוכים באמצעות סט
הרפידות המצורף.

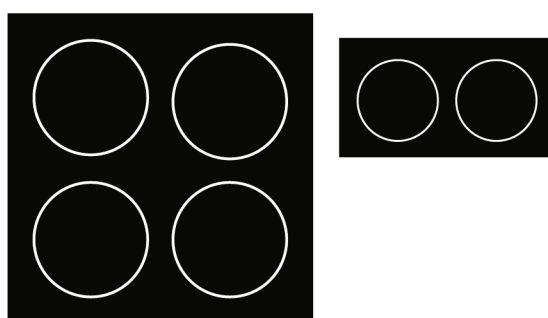



כיצד להתאים את הרווח בין מוטות העברת

ההילוכים

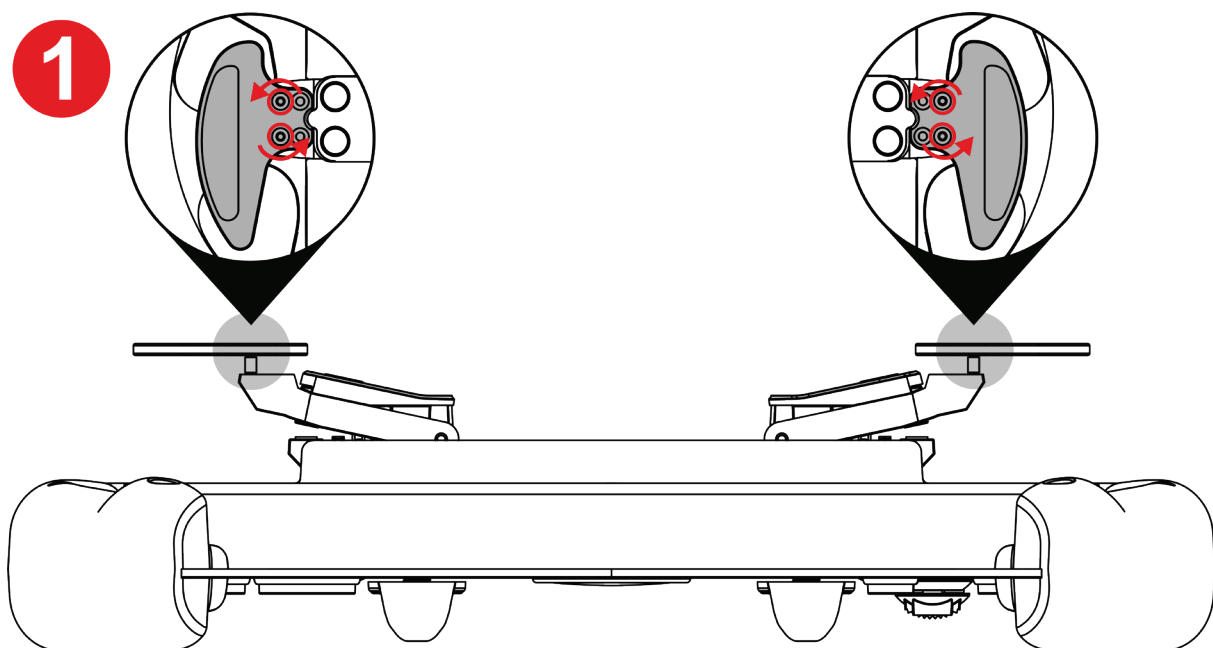

1 יש להבריג החוצה את ארבעת הברגים של מוטות העברת ההילוכים באמצעות מפתח הטורקס המצורף.

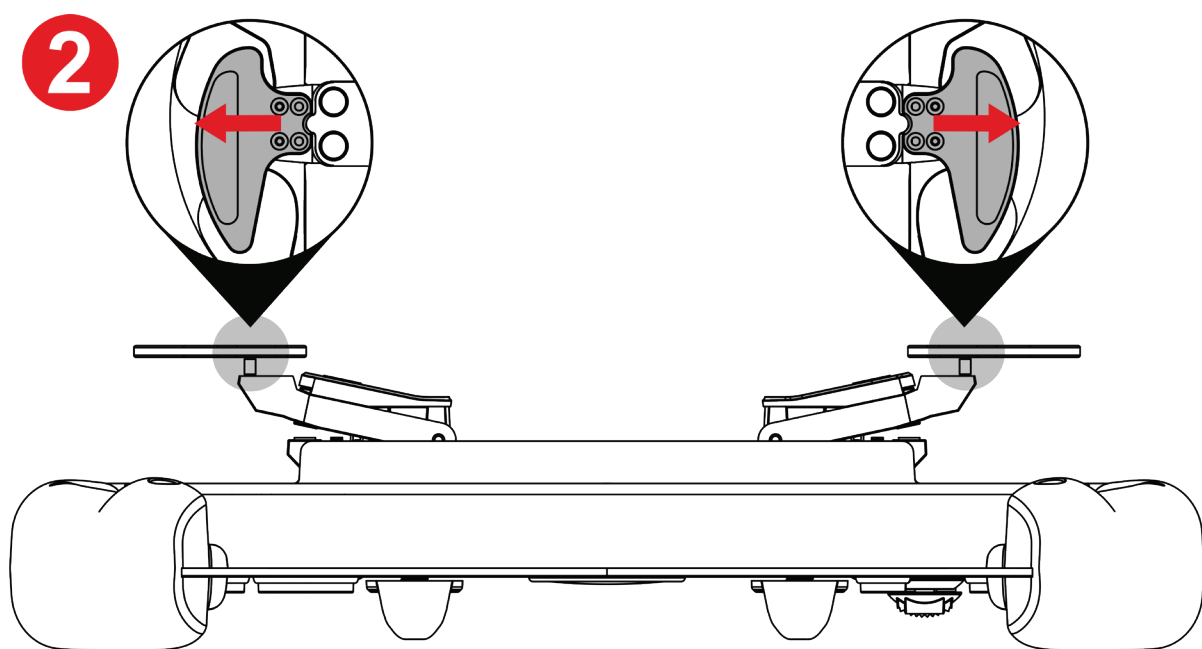

2 יש להסיט את מוטות העברת ההילוכים כלפי חוץ כדי להתאים לחורים.



3

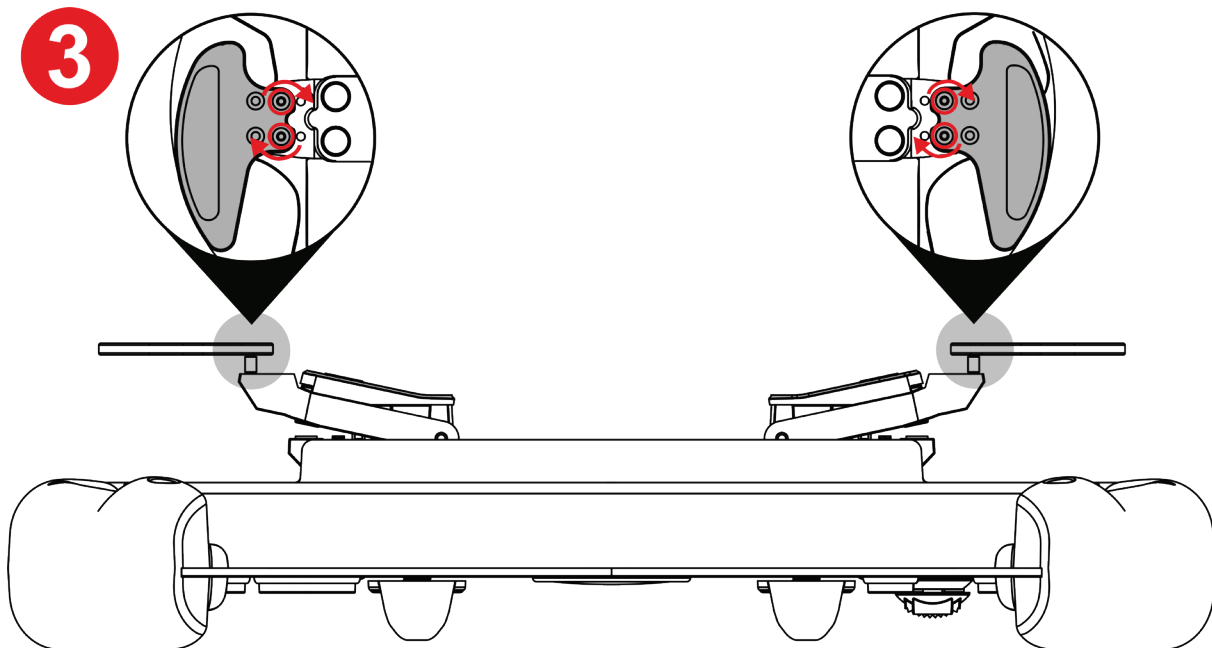

3 יש להדק את ארבעת הברגים של מוטות העברת ההילוכים באמצעות מפתח הטורקס המצורף.



כיצד להתאים את הטווח של מוטות העברת

ההילוכים

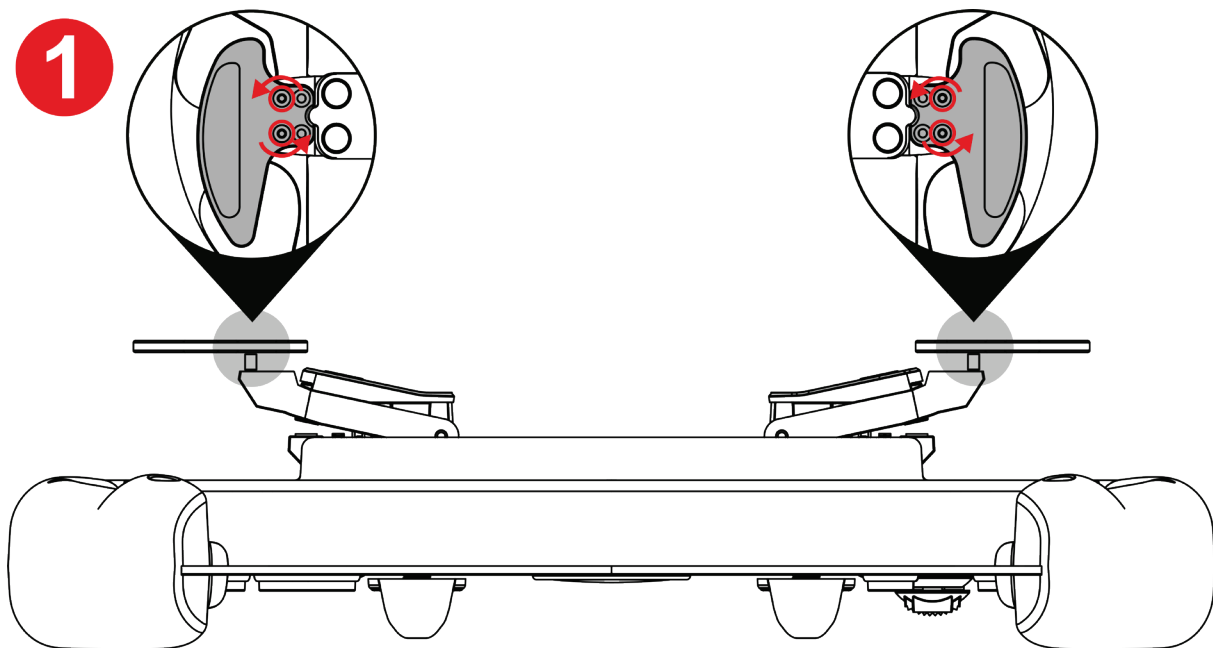

1 יש להבריג החוצה את ארבעת הברגים של מוטות העברת ההילוכים באמצעות מפתח הטורקס המצורף.

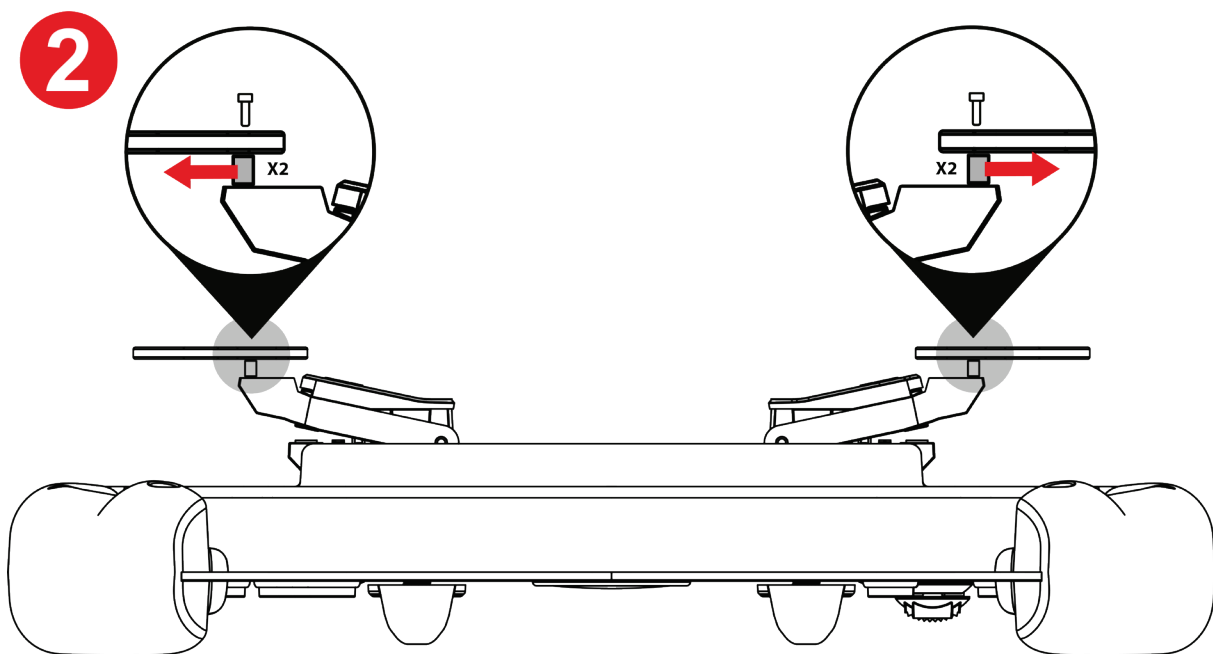

2 יש להסיר את המרווחים.



3

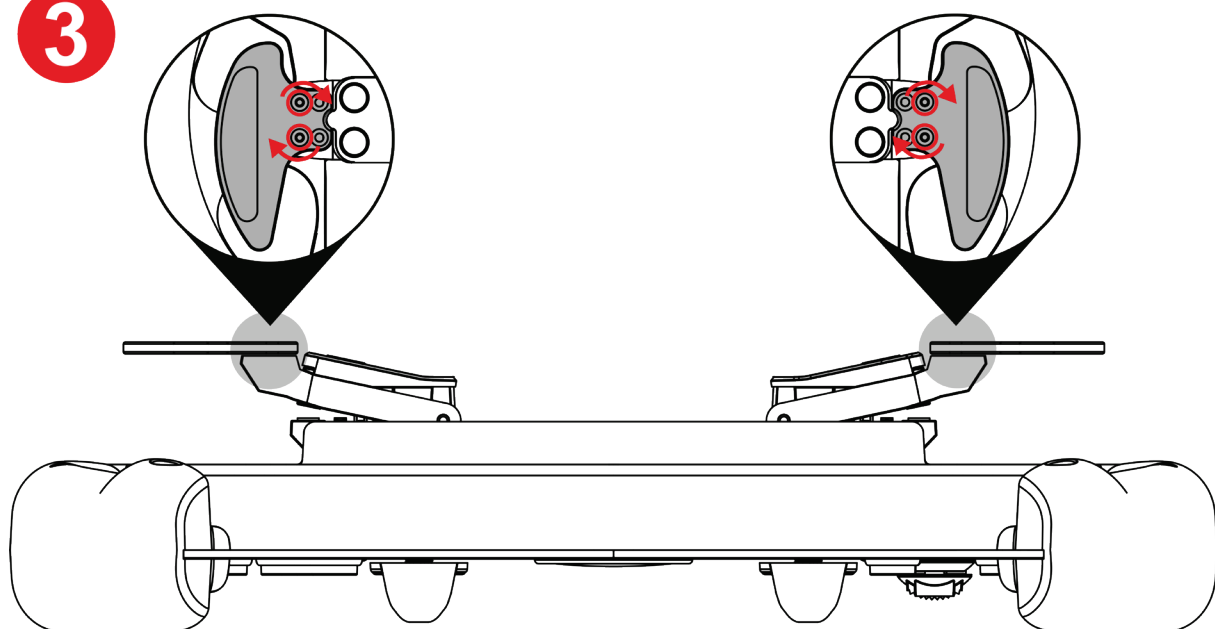

3 יש להדק את ארבעת הברגים של מוטות העברת ההילוכים באמצעות מפתח הטורקס המצורף.



כיצד להתאים את הרגישות המגנטית ואת רמת הצליל של מוטות העברת ההילוכים

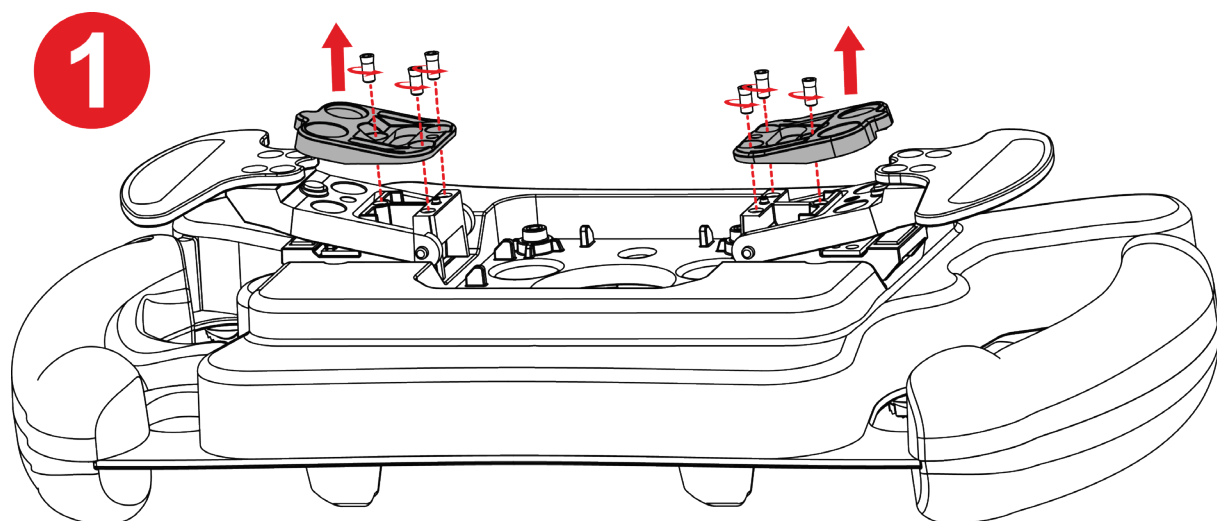

1 יש להסיר את המעצורים המגנטיים על ידי שחרור ששת ברגי העצירה באמצעות מפתח הטורקס המצורף.

2

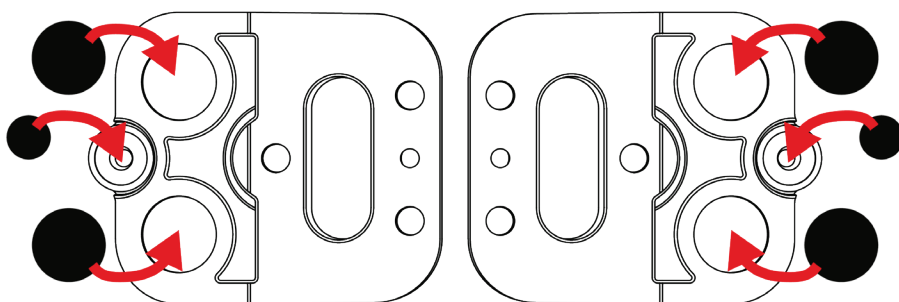
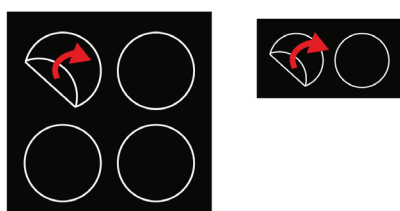

2 יש לקלף את הרפידות המצורפות ולהצמיד אותן במקומות המתאימים מתחת למעצורים המגנטיים.



ניתן לעיין בטבלת הנחת הצליל של רגישות מגנטית ומוטות העברת ההילוכים לקבלת תצורות אפשריות ולקבלת האפקטים שלהן.





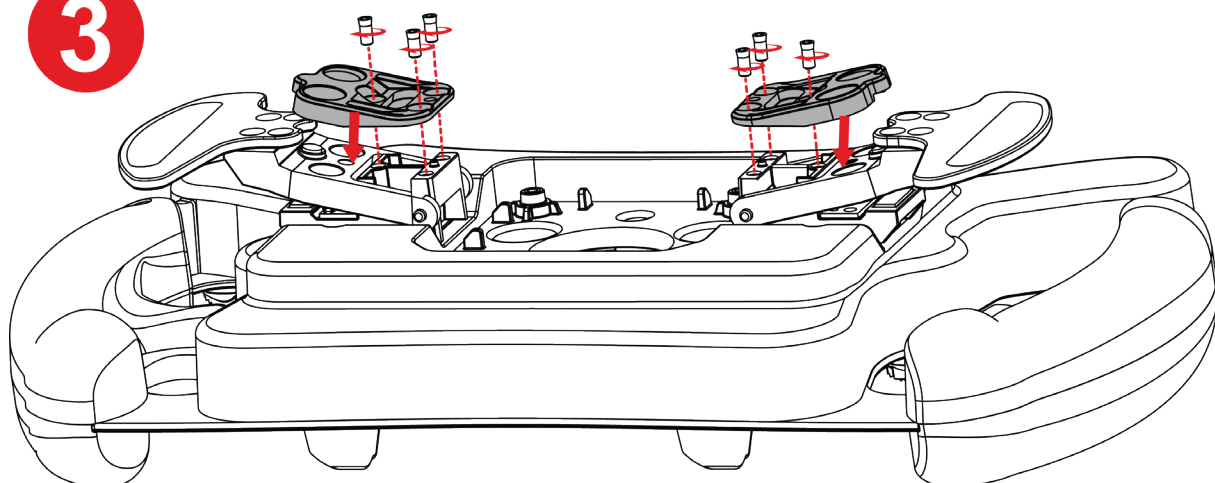

3

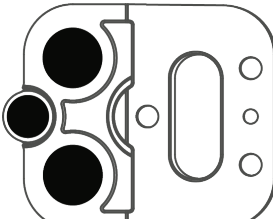
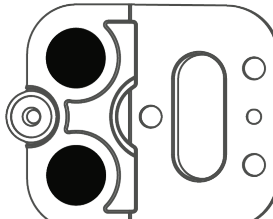
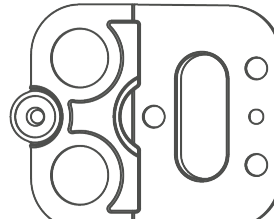

3 יש להתקין מחדש את המעצורים המגנטיים ולהדק את ששת ברגי העצירה באמצעות מפתח הטורקס המצורף.

רגישות מגנטית ושולחן הנחתת הצליל של מוט העברת ההילוכים

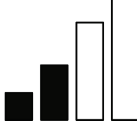
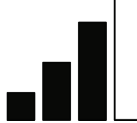
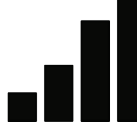
			
		ברירת (מחדל)	
			רגישות מגנטית
			צליל



8. שאלות נפוצות ותמיכה טכנית

האם יש לך שאלות בנוגע ל-Ferrari 488 GT3 Wheel Add-On, או שנתקלת בבעיות טכניות? אם כן, ניתן לבקר באתר התמיכה הטכנית של Thrustmaster:

<https://support.thrustmaster.com/product/ferrarif488gt3addon>

בעמוד זה ניתן גם לעדכן את הקושחה של ההגה.

