

# BTV-220 Manual

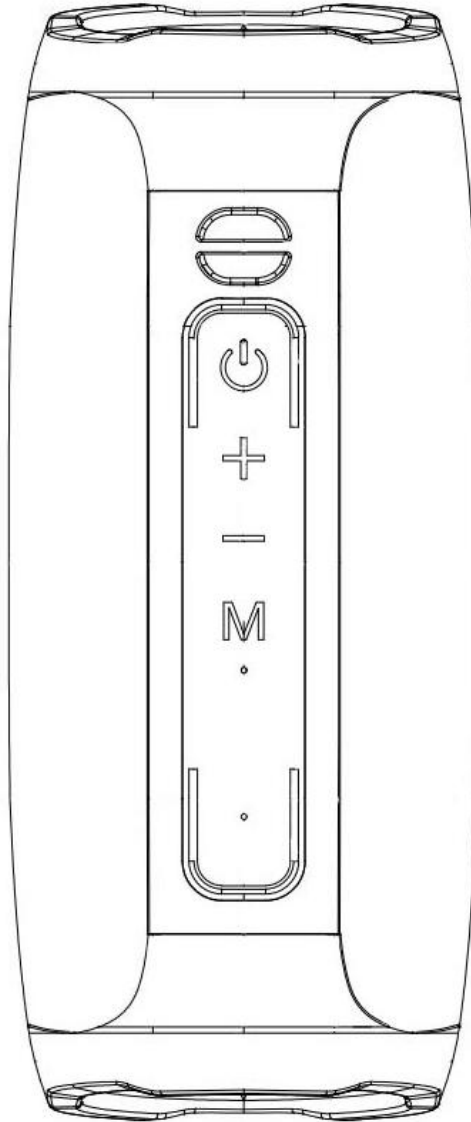

## CHARGING

The speaker must be recharged when switched off.

1. Use the supplied USB cable and connect it to the micro USB jack (1) of the speaker and the USB port of a PC or USB charger (5V, 1A, not included).

2.The LED indicator will light up red to indicate the charging status of the speaker; when fully charged, the LED indicator will turn off.

## **BASIC OPERATION**

To turn the speaker on, press and hold the power button (2).

Press the M button (5) to select

1. Bluetooth mode.

2. microSD mode: If a microSD card is connected to the microSD slot (6), the speaker will start playing the contents automatically.

3. USB Mode: If a USB stick is connected to the USB port (7), the speaker will start playing the contents automatically.

## **ADJUSTING THE VOLUME**

Press and hold the Volume - (4), Volume + (3) buttons to decrease or increase the volume.

## **AUX IN**

1. Turn on the speaker.

2. Connect an aux-in cable to the AUX IN jack (8) of the speaker and to an external device.

3. Start playing the contents from the external device.

## **USING A MICROSD CARD/USB STICK**

1. Turn on the speaker.

2. Connect a microSD card to the microSD slot (6) with the contacts facing left or connect a USB stick to the USB port.

3. The contents will start playing automatically.

4. Press the Volume-/Previous track button (4) once to skip to the previous track; press the Volume +/Next track button (3) to skip to the next track.

5. Press the Power button (2) to pause or resume playback.

## **BLUETOOTH OPERATION**

## **PAIRING DEVICES**

1. Place the speaker next to the Bluetooth device to be paired.
2. Turn the speaker on and press the M button (5) to enter Bluetooth mode.
3. Follow the instructions of your device to search the speaker.
4. The speaker's name is "Denver BTV-220" and will be displayed in your Bluetooth device's list. Select it and enter the password "0000", if required.
5. When paired successfully, you can stream music from your Bluetooth device to the speaker.

## **BUTTONS IN BLUETOOTH MODE**

1. Press the Volume-/Previous track button (4) once to skip to the previous track; press the Volume +/Next track button (3) to skip to the next track.
2. Press the Power button (2) to pause or resume playback.
3. If you receive a call, press the Power button (2) to answer the call and activate the speaker phone feature. To end the call, press the Power button (2) again.

## **TRUE WIRELESS STEREO BLUETOOTH CONNECTION (TWS FUNCTION FOR TWO SPEAKERS)**

1. Power on two speakers; the default setting is Bluetooth mode (a beep tone is heard confirming the speaker is set into Bluetooth pairing mode).
2. Turn off the Bluetooth function on your phone or other Bluetooth device, press and hold the M button (5) of either speaker (a beep tone is heard confirming the TWS function). After a few seconds you hear two Bluetooth speakers voice prompt, the two speakers are connected.
3. Open the Bluetooth search function on your mobile phone - search for "Denver BTV-220".
4. After finding "Denver BTV-220" select to connect.
5. You hear a Bluetooth speaker voice prompt to confirm the Bluetooth connection. Now you can enjoy music from two speakers.

6. Press and hold the M button (5) again to quit the TWS function to hear music from one speaker.

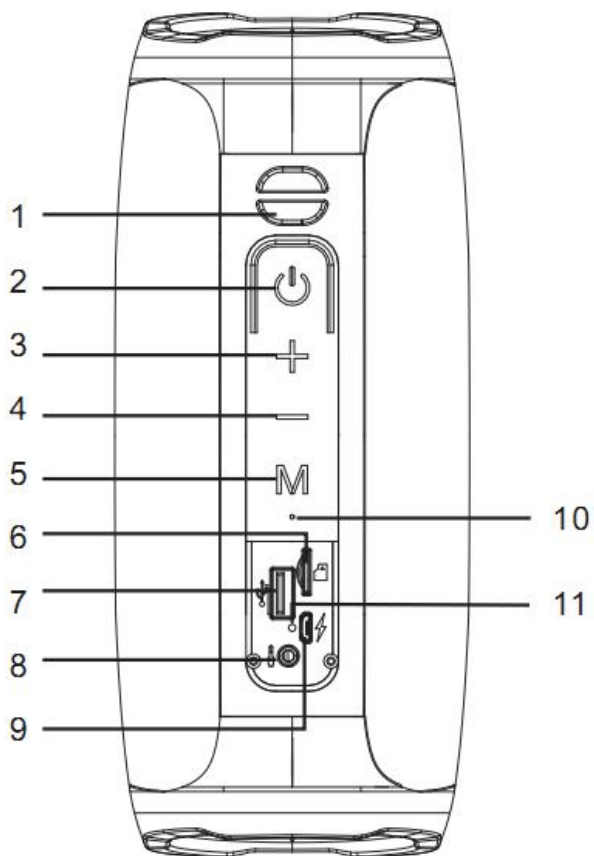

2	On / Off / Play / Pause
3	Volume + / Next track
4	Volume - / Previous track
5	Mode / FM tuning / TWS
6	microSD slot
7	USB port
8	Aux-in
9	USB charging port
10	MIC

11	LED status indicator
----	----------------------

## Supported music format: MP3

LED status indicator:

red: charging, turns off when charging is complete

blue: operating

## TECHNICAL FEATURES

Rechargeable Battery: ..... Internal lithium: 3.7V, 2400mAh

Power: ..... 5V 1A

Bluetooth Frequency Range: ..... 2402MHz~2480MHz

Operating Frequency Range: ..... 20Hz~20KHz

Max Output Power: ..... 42dBm

Dimensions: ..... 230 x 96 x 96 mm

Weight: ..... 798g

Please notice - All products are subject to change without any notice. We take reservations for errors and omissions in the manual.

ALL RIGHTS RESERVED, COPYRIGHT DENVER ELECTRONICS A/S

DENVER®

[www.denver-electronics.com](http://www.denver-electronics.com)



Electric and electronic equipment and included batteries contains materials, components and substances that can be hazardous to your health and the environment, if the waste material (discarded electric and electronic equipment and batteries) is not handled correctly.

Electric and electronic equipment and batteries is marked with the crossed out trash can symbol, seen above. This symbol signifies that electric and electronic equipment and batteries should not be disposed of with other household waste, but should be disposed of separately.

As the end user it is important that you submit your used batteries to the appropriate and designated facility. In this manner you make sure that the batteries are recycled in accordance with legislature and will not harm the environment.

All cities have established collection points, where electric and electronic equipment and batteries can either be submitted free of charge at recycling stations and other collection sites, or be collected from the households. Additional information is available at the technical department of your city.

Hereby, Inter Sales A/S declares that the radio equipment type BTV220 is in compliance with Directive 2014/53/EU. The full text of the EU declaration of conformity is available at the following internet address: [www.denver-electronics.com](http://www.denver-electronics.com) and then click the search ICON on topline of website. Write model number: BTV220. Now enter product page, and RED directive is found under downloads/other downloads.

Operating Frequency Range:20Hz~20KHz

Max Output Power:42dBm

DENVER ELECTRONICS A/S

Omega 5A, Soeften

DK-8382 Hinnerup

Denmark

[www.facebook.com/denverelectronics](https://www.facebook.com/denverelectronics)