

Sharkoon

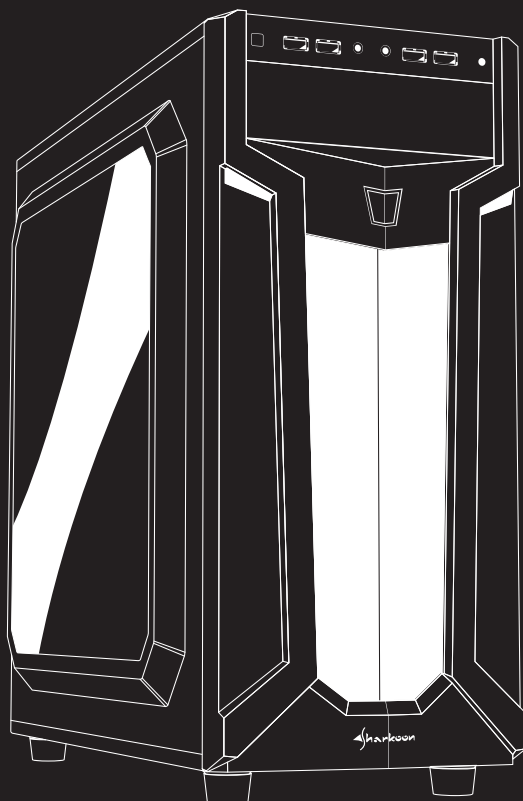

VG6

Manual • Anleitung • Manuel • Manuale dell'utente  
Handleiding • Instrukcja • Használati útmutató • Manuál  
Руководство пользователя • 使用説明 • マニュアル

# Specifications

- Spezifikationen
- Spécifications
- Specifiche tecniche
- Especificaciones
- Especificações
- Specificaties
- Спецификация
- Műszaki adatok
- Specifikace
- Технические характеристики
- 規格
- 仕様

<b>General:</b>	<b>VG6-W Red/ Green/ Blue</b>	<b>VG6-W RGB</b>
■ Form Factor	ATX	ATX
■ Expansion Slots	6	6
■ Interior Painting	✓	✓
■ Cable Management System	✓	✓
■ Side Panel	Acrylic	Acrylic
■ Chassis Color	Black	Black
■ Dimensions (L x W x H)	46.1 x 20.0 x 43.0 cm	46.1 x 20.0 x 43.0 cm

## I/O:

■ USB 3.0 (Front)	2	2
■ USB 2.0 (Front)	2	2
■ Audio (Front)	✓	✓

## Max. Drive Bays:

■ 5.25"	1	1
■ 3.5"	3	3
■ 2.5"	4	4

## Fan Configuration:

■ Front Panel	2x 120 mm LED Fans	2x 120 mm Addressable RGB LED Fans
■ Rear Panel	1x 120 mm LED Fan	1x 120 mm Addressable RGB LED Fans

## Compatibility:

■ Mainboard	Mini-ITX, Micro-ATX, ATX	Mini-ITX, Micro-ATX, ATX
■ Max. Length Graphics Cards	37.5 cm	37.5 cm
■ Max. Height CPU Cooler	16.5 cm	16.5 cm
■ Max. Length Power Supply	26.5 cm	26.5 cm

## Package Contents:

■ VG6-W, Accessory Set, Manual, Addressable RGB Hub (RGB Version)
---

# 2.5" HDD/SSD Installation

- Einbau 2,5"-HDD/SSD
- Installation disque dur/SSD 2,5"
- Installazione HDD/SSD da 2,5"
- Instalación de 2,5" HDD/SSD
- 2,5" Instalação HDD/SSD
- Installatie 2,5" HDD/SSD
- 2,5" montaž HDD/SSD
- 2,5" HDD/SSD beszerelhetőség
- Instalace 2,5" HDD/SSD
- Установка 2,5" HDD/SSD
- 2,5" 硬碟/SSD 安裝
- 2.5 インチ HDD/SSD の取付け

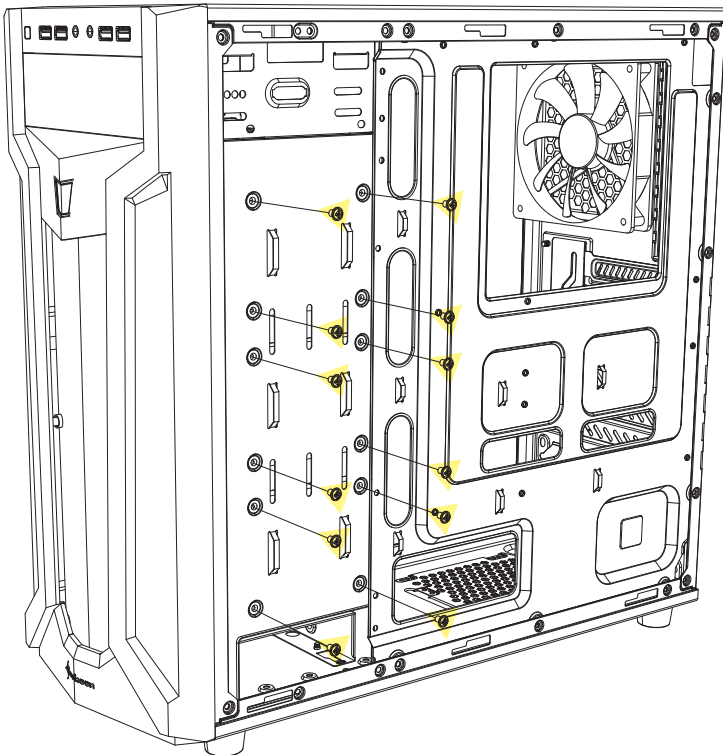
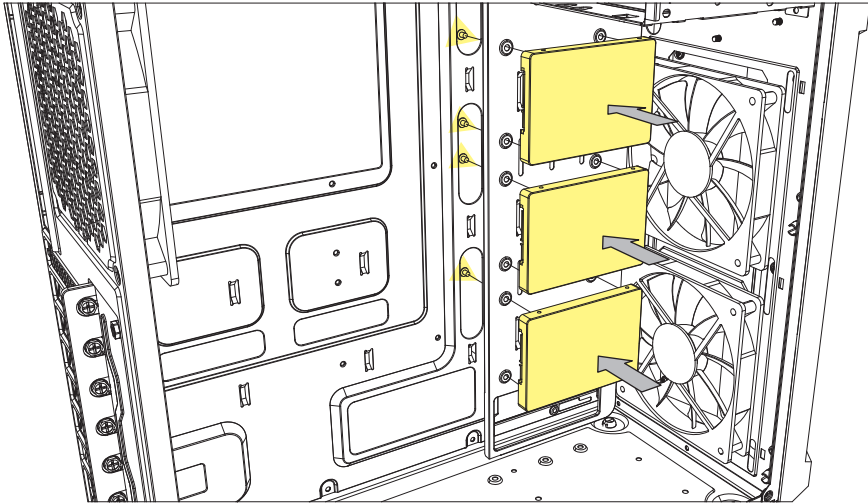

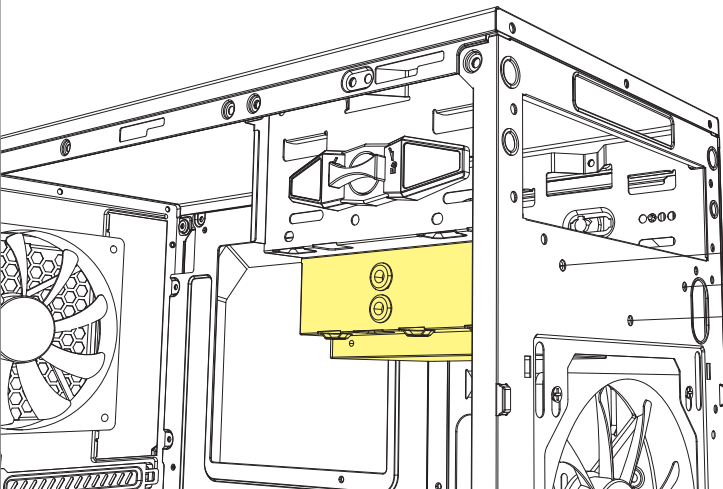
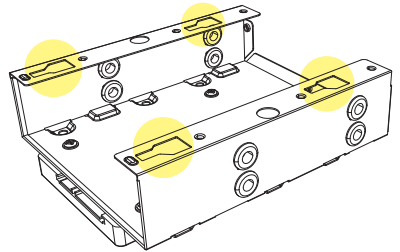
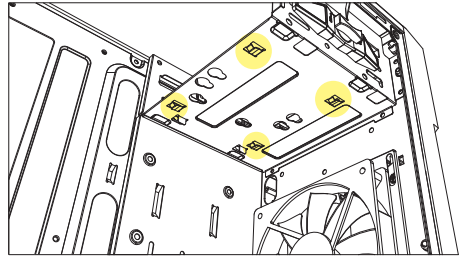
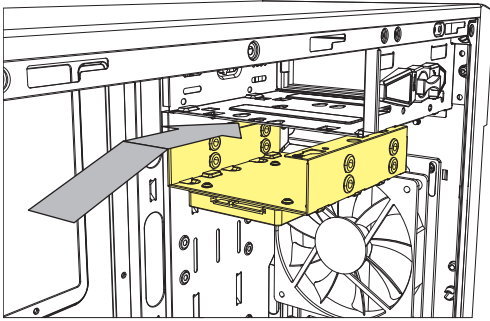
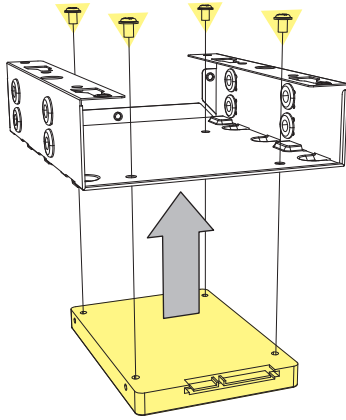

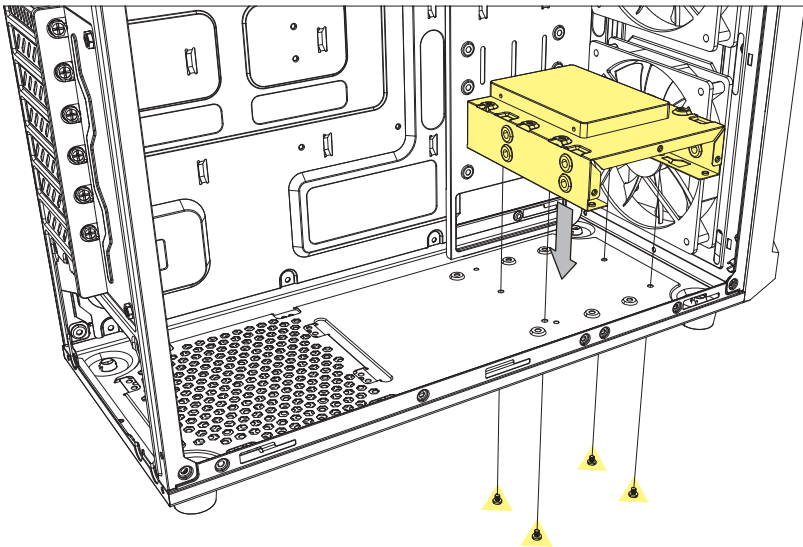
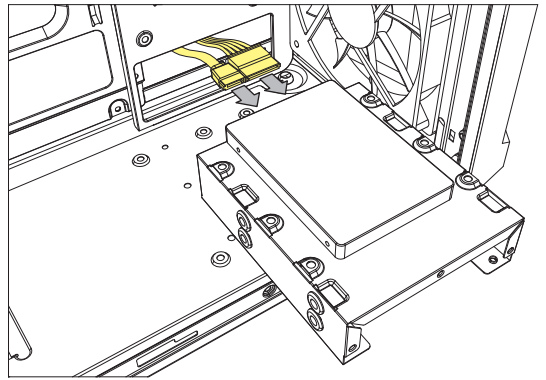
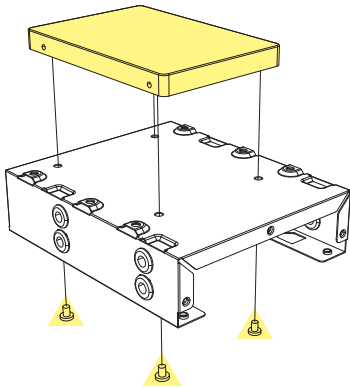
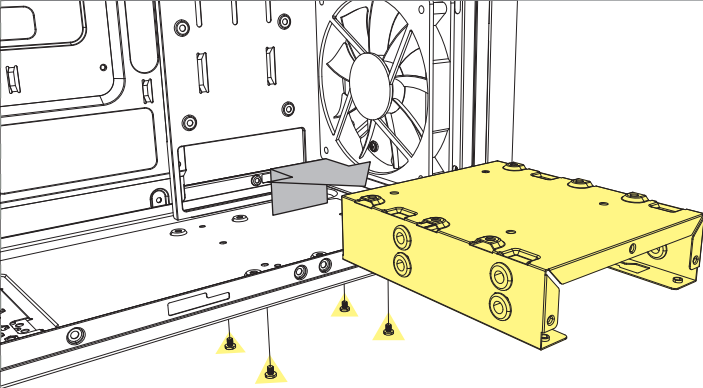

# 3.5" HDD Installation

- Einbau 3,5"-HDD
- Installation du disque dur de 3,5"
- Installazione HDD da 3,5"
- Instalación de 3,5" HDD
- 3,5" Instalação HDD
- Installatie 3,5" HDD
- 3,5" montaž dyskóv
- 3,5" HDD beszerelhetőség
- Instalace 3,5" HDD
- Установка 3,5" HDD
- 3,5" 硬碟安裝
- 3.5 インチハードディスクの取付け

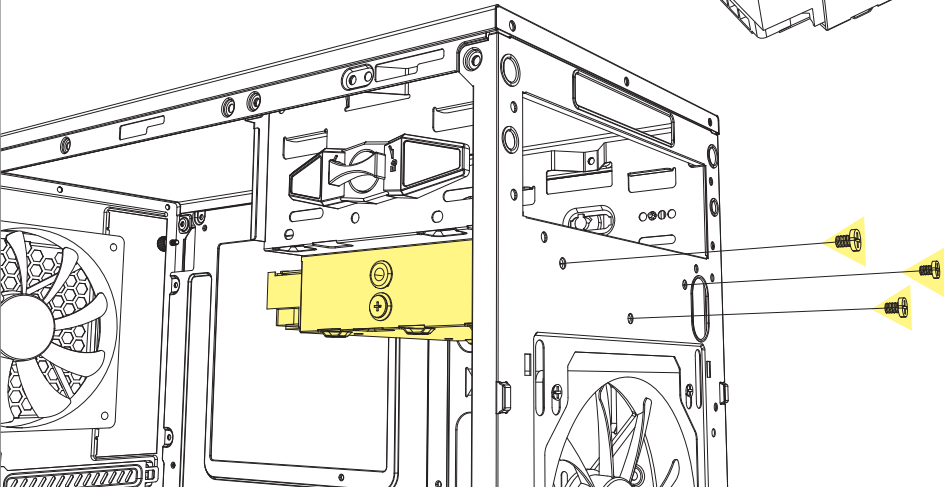
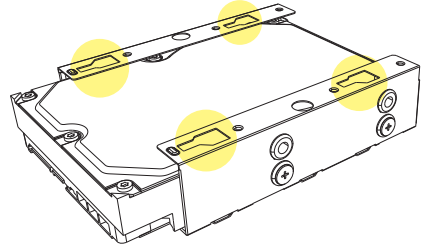
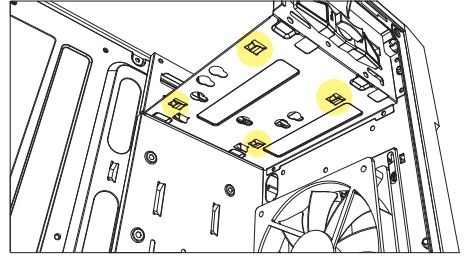
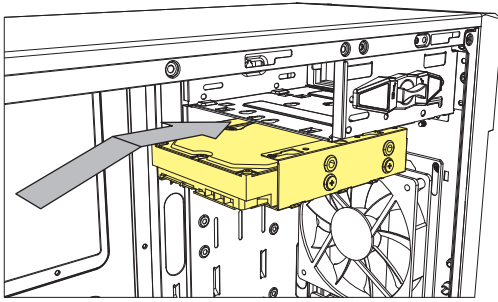
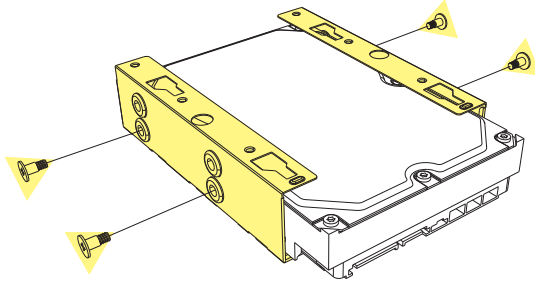

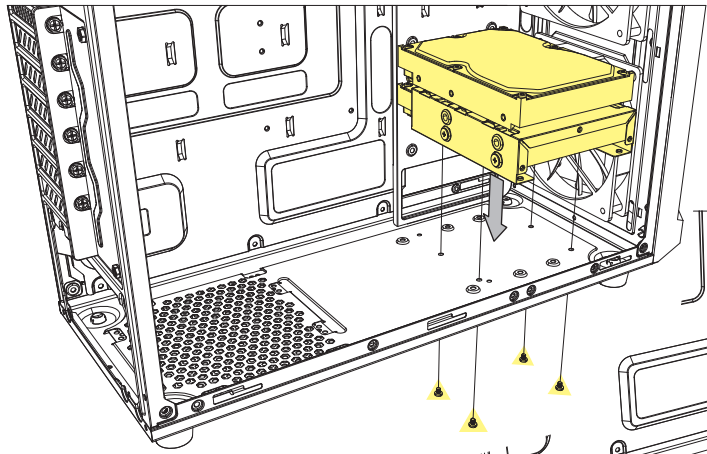
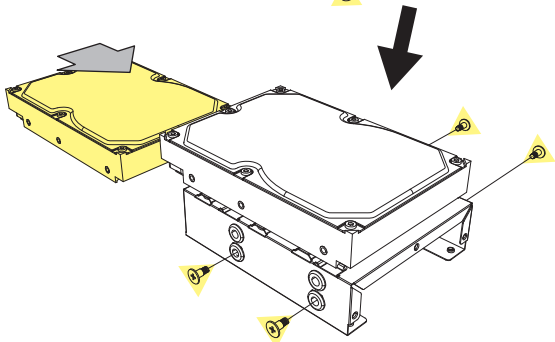
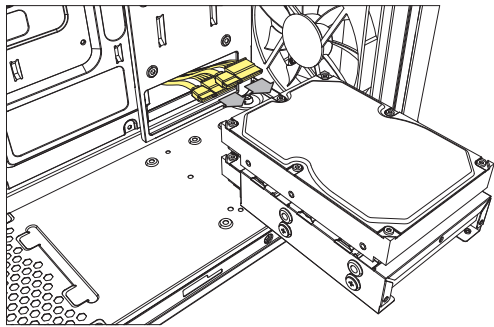
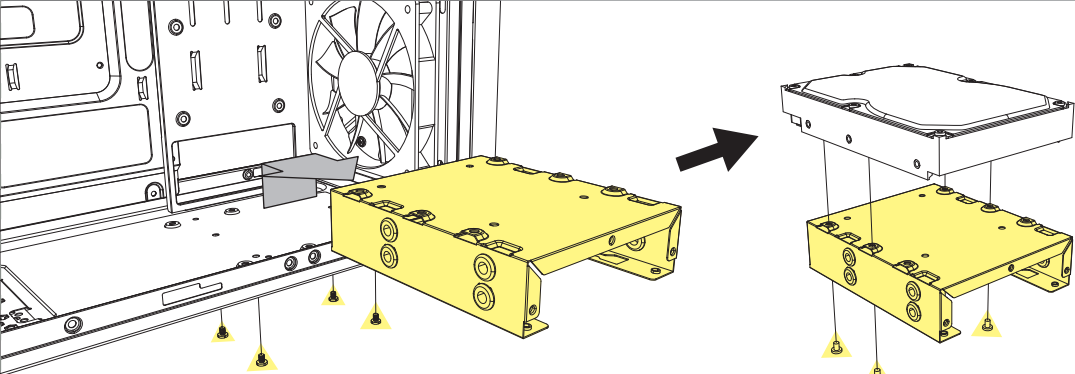

**OR**

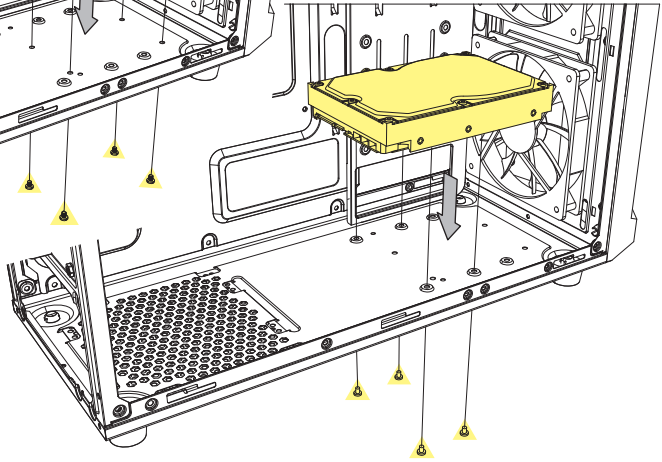

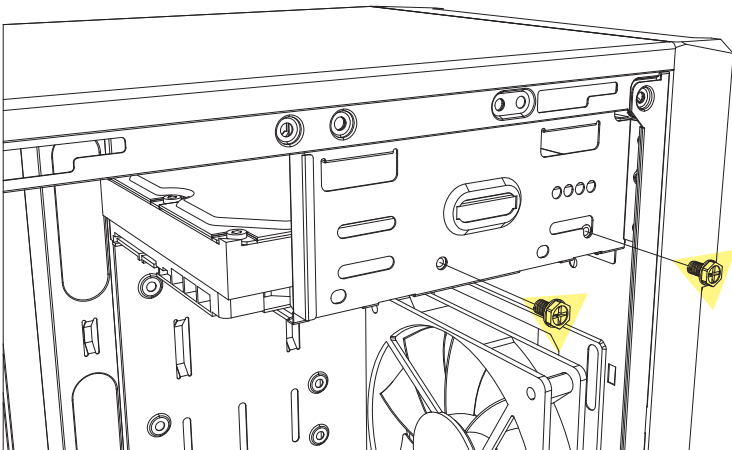
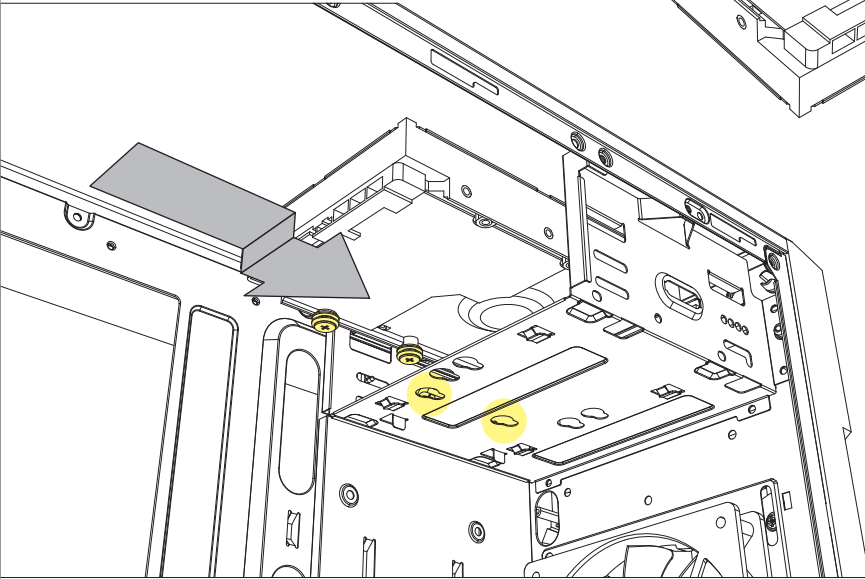
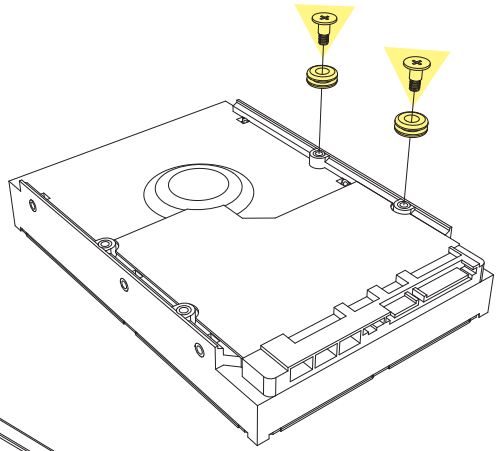



## 5.25" Device Installation

- Einbau 5,25"-Laufwerk
- Installation du périphérique 5,25"
- Installazione unità da 5,25"
- Instalación de dispositivo 5,25"
- 5,25" Instalação de dispositivo
- Installatie 5,25" apparaat
- 5,25" montaż urządzeń
- 5,25" eszköz beszerelhetőség
- Instalace 5,25" jednotky
- Установка устройства 5,25"
- 5,25" 装置安裝
- 5.25 インチデバイスの取付け

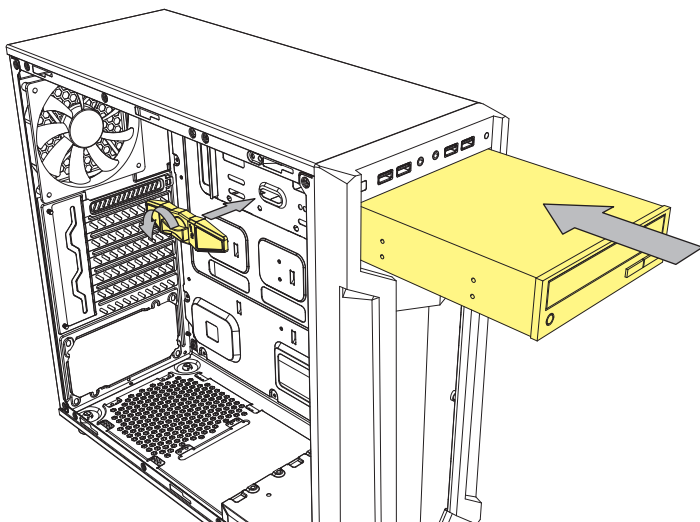
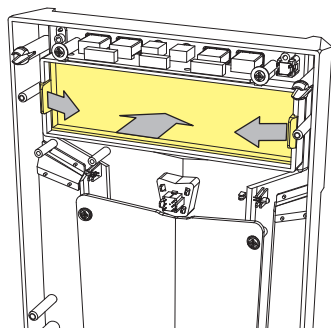

## Detachable Dust Filter

- Herausnehmbarer Staubfilter
- Filtre anti-poussière amovible
- Filtro antipolvere rimovibile
- Filtro de polvo desmontable
- Filtro de poeira destacável
- Afneembaar stoffilter
- Odczepialny filtr przeciwkurzowy
- Levehető porszűrő
- Oddítelný prachový filter
- Съемный пылевой фильтр
- 可拆卸式防塵濾網
- 着脱式ダストフィルター

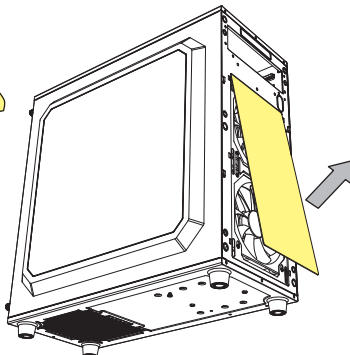
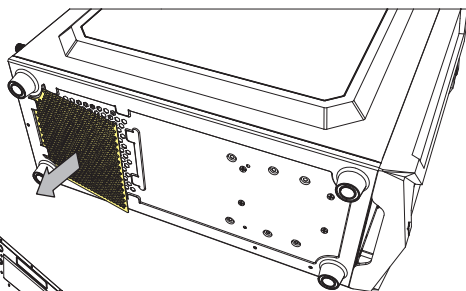
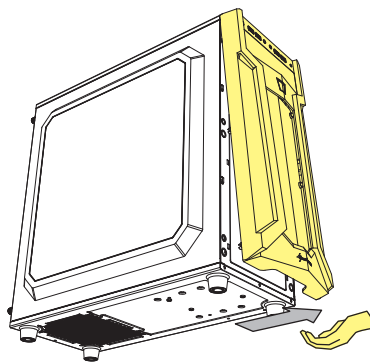

# Add-On Cards Installation

- Einbau Erweiterungskarten
- Installation des cartes d'extension
- Installazione di schede aggiuntive
- Instalación de tarjetas adicionales
- Instalação de cartões adicionais
- Installatie uitbreidingskaarten
- Montaż kart rozszerzeń
- Bővítőkártya beszerelhetőség
- Instalace karet na základní desku
- Установка дополнительных карт
- 介面卡安裝
- 増設カードの取付け

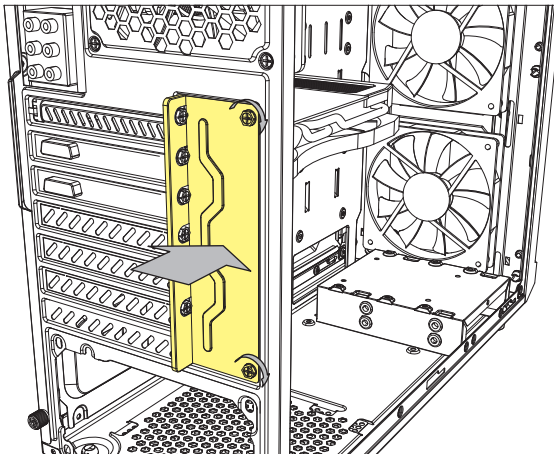
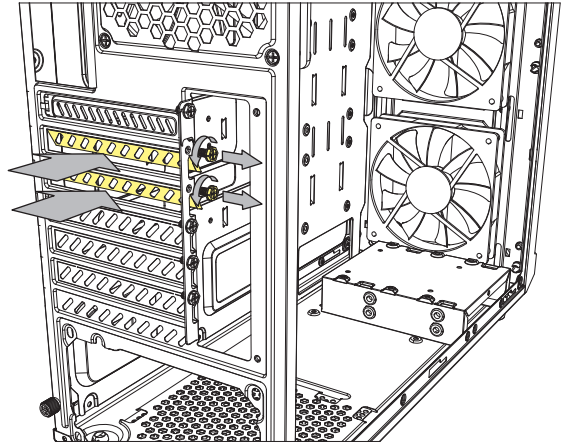
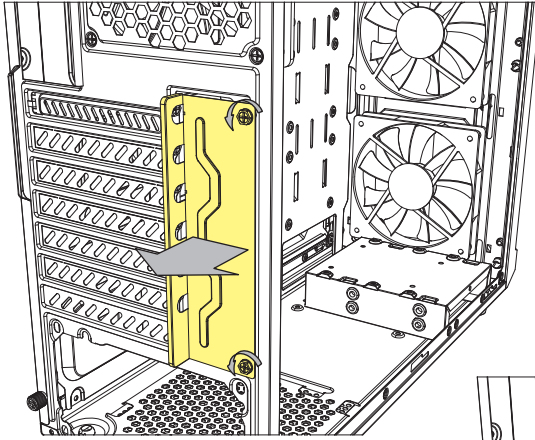

## Legal Disclaimer

For potential loss of data, especially due to inappropriate handling, Sharkoon assumes no liability.

All named products and descriptions are trademarks and/or registered trademarks of the respective manufacturers and are accepted as protected. As a continuing policy of product improvement at Sharkoon, the design and specifications are subject to change without prior notice. National product specifications may vary.

All rights reserved especially (also in extracts) for translation, reprinting, reproduction by copying or other technical means. Infringements will lead to compensation. All rights reserved especially in case of assignation of patent or utility patent. Means of delivery and technical modifications reserved.

## Disposal of your old products

Your product is designed and manufactured with high quality materials and components, which can be recycled and reused.



When this crossed-out wheeled bin symbol is attached to a product, it means the product is covered by the European Directive 2012/19/EU. Please be informed about the local separate collection system for electrical and electronic products. Please act according to your local rules and do not dispose of your old products with your normal household waste. The correct disposal of your old product will help prevent potential negative consequences to the environment and human health.

## Rechtliche Hinweise

Für evtl. auftretenden Datenverlust, insbesondere durch unsachgemäße Handhabung, übernimmt Sharkoon keine Haftung. Alle genannten Produkte und Bezeichnungen sind Warenzeichen und/oder eingetragene Warenzeichen der jeweiligen Hersteller und werden als geschützt anerkannt. Als ein Teil von Sharkoons Politik der fortwährenden Produktverbesserung unterliegen Produktdesign und -spezifikationen Änderungen ohne vorherige Ankündigung. Die Spezifikationen können in verschiedenen Ländern variieren. Alle Rechte vorbehalten, insbesondere (auch auszugsweise) die der Übersetzung, des Nachdrucks, der Wiedergabe durch Kopieren oder ähnliche Verfahren. Zuwiderhandlungen verpflichten zu Schadenersatz. Alle Rechte vorbehalten, insbesondere für den Fall der Patenterteilung oder GM-Eintragung. Liefermöglichkeiten und technische Änderungen vorbehalten.

## Entsorgung Ihres alten Gerätes

Ihr Gerät wurde unter Verwendung hochwertiger Materialien und Komponenten entwickelt und hergestellt, die recycelt und wiederverwendet werden können.



Befindet sich dieses Symbol (durchgestrichene Abfalltonne auf Rädern) auf dem Gerät, bedeutet dies, dass für dieses Gerät die Europäische Richtlinie 2012/19/EU gilt. Informieren Sie sich über die geltenden Bestimmungen zur getrennten Sammlung von Elektro- und Elektronik-Altgeräten in Ihrem Land. Richten Sie sich bitte nach den geltenden Bestimmungen in Ihrem Land, und entsorgen Sie Altgeräte nicht über Ihren Haushaltsabfall. Durch die korrekte Entsorgung Ihrer Altgeräte werden Umwelt und Menschen vor möglichen negativen Folgen geschützt.

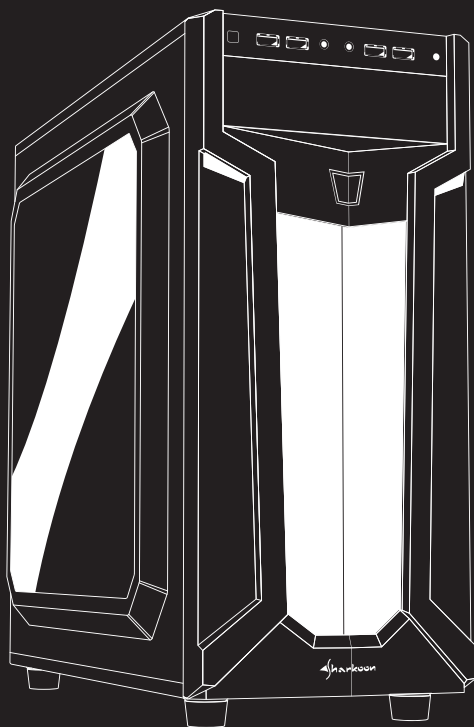

**Sharkoon Technologies GmbH**  
Grüninger Weg 48  
35415 Pohlheim  
Germany

© **Sharkoon Technologies 2019**