

■ Operating and installation instructions

REMKO TK series

Mobile dehumidifiers

TK 300



Contents

<i>Air dehumidification</i>	4-6
<i>Safety notes</i>	6-12
<i>Unit description</i>	13
<i>Set-up</i>	14
<i>Commissioning</i>	15-17
<i>Shutdown</i>	17
<i>Unit transport</i>	18
<i>Care and maintenance</i>	18-19
<i>Troubleshooting</i>	19-20
<i>Electrical wiring diagram</i>	20
<i>Intended use</i>	21
<i>Customer service and guarantee</i>	21
<i>Environmental protection and recycling</i>	21
<i>Exploded view of the unit</i>	22
<i>Spare parts list</i>	23
<i>Maintenance protocol</i>	24
<i>Technical data</i>	25

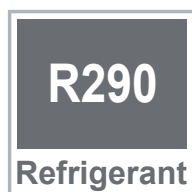

Carefully read this operating manual prior to commissioning/using the unit!
This operating manual is a translation of the German original.

This manual is an integral part of the unit and must always be kept in the vicinity of the installation location or on the unit itself.

Subject to modifications; no liability accepted for errors or misprints!

REMKO TK series

Air dehumidification

The correlations occurring when air is dehumidified are based on physical laws.

These are depicted here in graphical form in order to provide you with a brief overview of the principles of air dehumidification.

The use of REMKO air dehumidifiers

- Even if windows and doors are well insulated, water and moisture are still capable of penetrating thick concrete walls.
- The water required for setting when producing concrete, mortar and plaster etc. may only be diffused after 1-2 months.
- Even moisture trapped in the masonry after a flood is released very slowly.
- The same is also true of moisture contained in stored materials for example.

The moisture (water vapour) released from parts of a building or materials is absorbed by the surrounding air. As a result, the moisture content increases, which ultimately gives rise to corrosion, mould, rot, peeling of paint and other unwanted damage.

By way of example, the diagram shows the corrosion rate of metal in different levels of humidity.

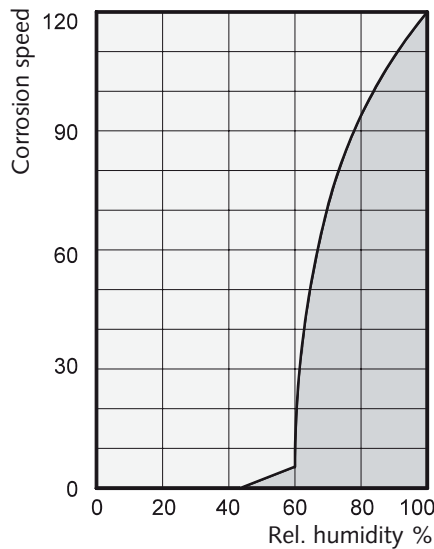

It is evident that the corrosion rate below 50 % relative humidity (RH) is low, and below 40 % is negligible.

The corrosion rate increases significantly above 60 % RH. This threshold for damage as the result of humidity also applies to other materials, such as powdery substances, packaging, wood and electronic units.

Buildings may be dried in a variety of ways:

1. By heating and air exchange:

The air in the room is heated in order for moisture to be removed and then this air is fed outside. All of the energy that is involved is lost together with the moist air that is released.

2. By air dehumidification:

The moist air that is present within an enclosed space is continuously dehumidified according to the condensation principle.

With regard to energy consumption, air dehumidification has one distinct advantage:

Energy expenditure is limited exclusively to the air volumes present. The mechanical heat that is released by the dehumidification process is fed back into the room.

Under normal use, the air dehumidifier uses approximately 25 % of the energy that is required for the "heating and ventilating" principle.

Relative air humidity

Our ambient air is a gaseous mixture which always contains a certain volume of water in the form of water vapour. This volume of water is specified in g per kg of dry air (absolute moisture content).

1 m³ of air weighs approx. 1.2 kg at 20 °C

Depending on the temperature, each kg of air is only capable of absorbing a certain volume of water vapour. Once this capacity has been reached, the air is referred to as "saturated" and has a relative humidity (RH) of 100 %.

Relative humidity is understood to mean the ratio between the current quantity of water vapour in the air and the maximum possible quantity of water vapour at the same temperature.

The ability of the air to absorb water vapour increases as the temperature rises. I.e. the maximum possible (absolute) water content becomes greater as the temperature rises.

Temp. °C	Water vapour content in g/m ³ at humidity of			
	40 %	60 %	80 %	100 %
-5	1.3	1.9	2.6	3.3
+10	3.8	5.6	7.5	9.4
+15	5.1	7.7	10.2	12.8
+20	6.9	10.4	13.8	17.3
+25	9.2	13.8	18.4	23.0
+30	12.9	18.2	24.3	30.3

Water vapour condensation

Because the capacity for the maximum possible volume of water vapour increases as the air is heated, the volume of water vapour contained remains constant and so relative humidity falls.

In contrast, because the capacity for the maximum possible volume of water vapour decreases as the air is cooled, the volume of water vapour contained remains constant and so relative humidity increases. If the temperature continues to fall, the capacity for the maximum possible volume of water vapour is reduced so much so that it is ultimately equal to the volume of water vapour contained in the air. This temperature is referred to as the dew point. If the air is cooled to below the dew point, the volume of water vapour in the air will become greater than the maximum possible volume of water vapour.

At this point, the water vapour begins to precipitate. This condenses to water and moisture is removed from the air.

Examples of condensation include steamed-up window panes in winter, or the moisture on the outside of a cold drinks bottle.



As the relative humidity of the air increases, so too does the dew point, making it easier for the temperature to fall below it.

Drying materials

Building materials and structures are capable of absorbing considerable volumes of water, such as brick 90-190 l/m³, heavy concrete 140-190 l/m³ and limestone 180-270 l/m³. The drying of moist materials such as masonry is effected as follows:

- The moisture moves from the inside of the material to its surface

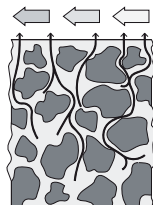

- Evaporation occurs on the surface = Transfer of water vapour to the ambient air

- The air containing water vapour is constantly circulated through the REMKO air dehumidifier. The air is dehumidified and, slightly heated, leaves the unit in order to re-absorb water vapour

- In this way, the moisture contained in the material is reduced gradually
The material is dried!

The accumulated condensate is collected in the unit and drained off from there.

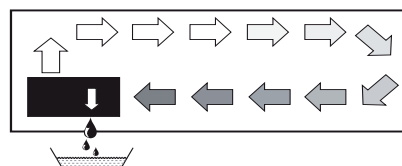

As it flows through or over the evaporator, the air stream is cooled to dew point. The water vapour condenses, and is collected in a condensate trap from where it is drained off.

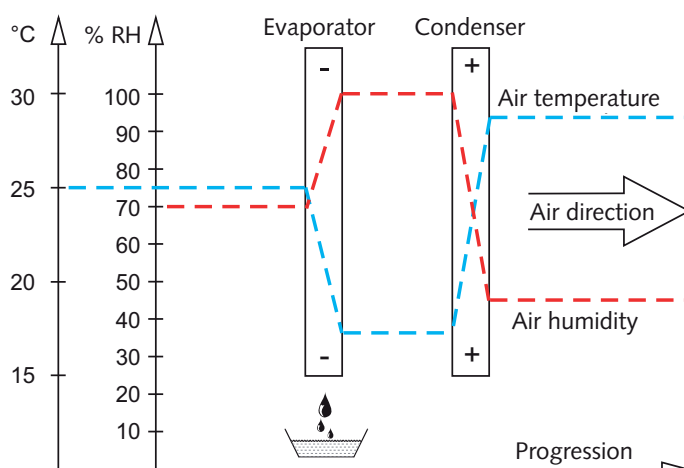

REMKO TK series

Condensation heat

The Energy transferred to the air from the condenser consists of:

1. The amount of heat derived beforehand in the evaporator.
2. The electrical drive energy.
3. The condensation heat released by liquefying the water vapour.

Energy must be supplied when liquid is converted into a gas. This energy is designated as evaporation heat. It does not cause any increase in temperature, but is required to convert a liquid into a gas. Conversely, energy is released when gas is liquefied, this is designated as condensation heat.

The amount of energy from evaporation heat and condensation heat is the same.

**For water, this is:
2250 kJ/kg (4.18 kJ = 1kcal)**

From this it is evident that the condensation of water vapour causes a large quantity of energy to be released.

If the moisture that it is to be condensed is not introduced by evaporation in the room itself, but from outside, e.g. through ventilation, the condensation heat released contributes to the heating of the room. With drying operations, a heat cycle is created, whereby heat is consumed for evaporation

and released for condensation. When dehumidifying fed air, a larger contribution of heat is created, which manifests itself as a temperature increase.

Generally speaking, the time required for the drying process is not only dependent on the output of the unit, but is determined to a greater extent by the speed at which the material or building section loses its moisture.

Safety notes

General safety notes

- Carefully read the manual before commissioning the units or their components for the first time. It provides useful tips and notes such as hazard warnings to prevent injury and material damage. Failure to follow the directions in this manual can endanger persons, the environment and the equipment itself or its components and will void any claims for liability.
- Store this manual and the information required for the operation of this system (e.g. refrigerant datasheet) in the vicinity of the units.
- This unit may only be installed and operated as described in this manual.
- Independent conversion and/or modification of any kind is strictly prohibited.
- National regulations in connection with installation must be observed.
- Children must not be left unsupervised when close to the unit.
- For safety reasons, people with mental, physical or other health limitations must not operate this unit unattended.
- The unit is not permitted to be operated with damaged cables. The unit must be repaired by a specialist immediately.
- The unit may only be operated via a power supply with grounding.
- The use of extension cables is not recommended.
- The air filter must be cleaned at intervals of no more than 2 weeks.
- The unit is not permitted to be operated in the vicinity of heat sources.
- The unit must be transported upright. Residue from the condensate must be drained off before transport. The unit must be stood upright for 1 hour prior to commissioning.
- Combustible substances and pressure containers must be kept at least 50 cm from the unit.
- The unit must not be stored and operated in rooms with oil, gas or sulphur.

- The unit must always be switched off with the on/off switch.
- Do not place anything on the device in particular heavy or hot objects.
- Repairs may only be carried out by authorised and certified specialist personnel.
- This unit must be disposed of professionally in accordance with environmental protection.
- The safety notes in regards to the room sizes and the flammability of the refrigerant must not be removed from the machine.
- The units may only be operated in well ventilated areas.
- The unit can be used by children 8 years and up and by persons without physical, mental or other health limitations if this knowledge has been obtained via the necessary safety notes..
- Children must never play with the unit.
- Cleaning the units must not be carried out by children without parental/guardian supervision.
- The appliance is intended only for indoor use (excluding laundry rooms).

The following notes must be observed in full:

- The units must not be operated at an ambient temperature below 5 °C.
- The units may not be set up or operated in explosive environments.
- The units must not be installed or operated in atmospheres containing oil, sulphur, chlorine, salt or dust.
- Never insert foreign objects into the units.
- The units may not be exposed to direct jets of water.
- An unobstructed air inlet and air outlet must be guaranteed at all times.
- The air-inlet grille must always be kept free of dirt and loose objects.
- The units must not be covered during operation.
- The units must be installed upright and in a stable position.
- The units must not be transported while they are running.
- All electrical cables on the outside of the units must be protected against damage (e.g. by animals etc.).
- Before each change of location, the condensate containers must be emptied.

- Appropriate hazard prevention measures must be taken to prevent risks to people when performing installation, repair, maintenance or cleaning work on the units.
- The units and components should not be exposed to any mechanical load, extreme levels of humidity or direct exposure to sunlight.

Additional safety notes when handling refrigerant R290



Warning of inflammable substances !

- The refrigerant R290 fulfils the requirements of the European F-Gas regulation.
- The units contain 0.122 kg of refrigerant R290 depending on the unit type.
- The maximum permitted amount of refrigerant R290 is 0.3 kg.
- The units must not be burned, drilled or pierced.
- Only use cleaning agents which have been approved by the manufacturer for cleaning.
- The unit must never be operated in rooms with naked flames (e.g. gas heaters, open fireplaces, etc.).
- Refrigerant circuit components must not be deformed.

REMKO TK series

- The contained refrigerant R290 is colourless and odourless.
- The unit must not be stored or operated in rooms which have a room area of 6 m² or less.
- The accumulation of refrigerant due to leakages can lead to a fire and explosions in rooms which are too small due to the development of heat or ignition sources.
- The units must be stored carefully. Mechanical damage must be avoided.
- Intervention in the refrigeration circuit may only be done by certified specialist personnel taking into account the safety notes of the manufacturer.
- Maintenance and repairs may only be carried out by authorised personnel which have the corresponding knowledge in regards to flammable refrigerant.

WARNING!

Do not use anything other than the agent recommended by the manufacturer to speed up a possible defrosting process or to clean the units. The unit may only be operated and stored in rooms where there are no devices with potential ignition sources. Do not go below the minimum room area of 6 m². Note that leaking refrigerant is colourless and odourless. The unit must not be burned or pierced!

Safety instructions for the operator

The operational safety of the units and components is only assured providing they are used as intended and in a fully assembled state.

- This unit may only be installed and operated as described in this manual.
- Independent conversion and/or modification of any kind is strictly prohibited.
- Children must not be left unsupervised when close to the unit.
- For safety reasons, people with mental, physical or other health limitations must not operate this unit unattended.
- The unit is not permitted to be operated with damaged cables. The unit must be repaired by a specialist immediately.
- The unit may only be operated via a power supply with grounding.
- The use of extension cables is not recommended.
- The air filter must be cleaned at intervals of no more than 2 weeks.
- The unit is not permitted to be operated in the vicinity of heat sources.
- The unit must be transported upright. Residue from the condensate must be drained off before transport. The unit must be stood upright for 1 hour prior to commissioning.
- Operating the units in rooms with potential ignition sources (naked flames, gas or electrical heaters, fireplaces) is prohibited.
- The unit may only be installed, operated and stored in rooms larger than 6 m².
- Protective covers (grilles) over moving parts must not be removed from units that are in operation.
- Do not operate units or components with obvious defects or signs of damage.
- Contact with equipment parts or components can lead to burns or injury.
- The units and components must not be exposed to any mechanical load, extreme levels of humidity or extreme temperatures.
- Never drill through the housing cover or have the unit come into contact with fire.
- Rooms in which refrigerant may escape must be adequately aerated and ventilated. Otherwise there is danger of suffocation.
- All housing parts and unit openings, e.g. air inlets and outlets, must be free from foreign objects, fluids or gases.
- Do not leave the units running for an extended period unsupervised.

Improper use can cause serious damage to the unit.
Read this manual carefully before commissioning!

Do not allow children to play with the unit.



Never cover the air inlets and outlets.



Safety notes for installation, maintenance and inspection

■ Check the work area

Before starting work on units with combustible refrigerants, ensure that any potential ignition sources are removed and the risk of igniting the refrigerants is eliminated. The aforementioned safety notes for repairing the units must be observed at all times. Work may only be carried out by authorised specialist personnel with knowledge of handling combustible refrigerants!

Do not stand or sit on the unit.



Unplug the power plug when not in use for a long period.



■ Prepare the work area

Any persons present must be informed about the repair process accordingly and persons not involved must vacate the work area. Working in rooms with limited space is prohibited. Ensure that sufficient space is available at the workplace. Ensure that the ambient conditions are suitable for working with combustible refrigerants.

Unplug the power plug before cleaning the unit.



Ensure the voltage is correct (220-240 V AC, 50 Hz).



■ Identify refrigerant leaks, check the atmosphere

Refrigerant may unexpectedly escape when working on the refrigerant circuit. Ensure that the atmosphere in the workplace is not combustible at all times by using suitable refrigerant detectors. Be sure to ensure that the refrigerant detector used is suitable, approved and calibrated for use with refrigerant R290.

Do not disassemble housing parts (consult a specialist company).



Do not operate the unit with defective cables or sockets.



The unit and in particular the control panel must not come into contact with water.



■ Provide fire extinguishers

Provide appropriate fire extinguishers before starting work. For this purpose, dry powder or CO₂ fire extinguishers are suitable.

REMKO TK series

■ Remove any potential ignition sources

Leaking refrigerant in combination with corresponding ignition sources can lead to an explosion. All ignition sources must therefore be kept away from the working area at all times! This also includes the smoking of cigarettes. Inform all persons present that this includes the affixing of safety notes and the closing off of the working area.

■ Sufficient ventilation

Before starting work, ensure that the working area is outdoors or has sufficient ventilation. A continuous ventilation stream is required while working. The safety of the persons working must be guaranteed by the exhaust air equipment: potentially leaking refrigerant must be lead away safely and drained into the atmosphere in an optimum manner.

■ Checking the refrigerant circuit

If electronic components need to be replaced, ensure that the spare parts have the same function and identical technical specifications. The maintenance and replacement regulations of the manufacturer must always be observed and complied with. Please contact the support of the manufacturer with any problems or queries. The following safety checks must be carried out when using combustible refrigerants:

- The fill level adjusts to the size of the rooms in which the unit is located.
- The exhaust air equipment and its outlets function properly and are not blocked or obstructed.

■ Checking the electronic components

A component and safety check must be carried out before repairing and maintaining electronic components. If safety cannot be ensured due to a defect on a component, installation must not take place until safety can be guaranteed again. If the defect on the spare part cannot be remedied and downtime of the unit is no longer acceptable, an adequate temporary solution must be arranged. The owner/operator of the unit must be informed about this. The detailed safety check must include the following aspects:

- Capacitors are discharged. Discharging must be done in a safe process to prevent flying sparks.
- There must be no electronic components active or uninsulated wires while filling, repairing or cleaning.
- There must be no earthing of the system.

■ Repairs to closed components

Before repairing closed components/housing parts, the unit must be free from voltage. If carrying out the repairs free from voltage cannot be avoided, the critical points of potential refrigerant leakages must be checked using a leak detector.

The following notes must be observed when working on electronic components if the housing is changed in such a way that its safety is influenced. This also relates to cases where the lines are damaged, there is excessive or incorrect pin assignment, connections are not assigned in the original way or similar deviations to the expected condition are determined.

■ Repairing of intrinsically safe components

Do not introduce permanent inductive or capacitive loads into the existing circuits without ensuring that the maximum permitted voltages and amperages of the assemblies and lines are not exceeded. Intrinsically safe components are individual components that can be operated in the presence of flammable substances. The test equipment must be adjusted according to the situation-dependent conditions. Only use components which are officially approved by the manufacturer as spare parts. Unapproved components can cause a fire in the event of a leakage in the refrigerant circuit.

■ Wiring

Lines must be checked for the following damage:

- Damage to the insulation
- Corrosion at the contact points
- Excessive pressure on the lines
- Damage due to vibrations
- Damage due to sharp edges
- Damage due to other influences not mentioned here

Also consider the ageing of the material and continuous vibration loads due to compressors or fans when checking.

■ Identify combustible refrigerant

Do not use any potential ignition source when searching for refrigerant leaks under any circumstance. The use of a leak detection lamp or other similar devices with a naked flame is not permitted.

1. Ensure that the components are installed correctly.
2. Ensure that sealing materials are not changed in such a way that combustible gases or objects could penetrate into the interior of the components.
3. Spare parts must correspond to the manufacturer's specifications.



NOTE

The use of silicones can influence the effectiveness of leak detection devices! Intrinsically safe components must not be insulated before starting work.

■ Leak detection methods

The following leak detection methods are permitted for systems with combustible refrigerants. Electronic equipment must be used for detecting leaks.

These must be selected with the sensitivity matched to the situation and recalibrated if necessary (calibration must take place in a refrigerant-free environment). The leak detection device must be adjusted to the lowest flammability limit (LFL) of the refrigerant. Liquid leakage instruments are permitted for most refrigerants. Chlorinated substances are the exception here as the chlorine in combination with the refrigerants can cause corrosion on the copper cables. If a leak is detected, all potential open ignition sources must be removed immediately. If a leak has been detected in the system which requires reworking of the piping in the form of soldering, the system must be completely free of refrigerant or, if possible, the affected part disconnected from the system using stopcocks. The affected system parts must be flushed with oxygen-free nitrogen run before and during the repair work.

■ Emptying and evacuating the system

If the refrigerant circuit must be opened for repairs or other reasons, this must be carried out in a safe and professional way. In any event, proceed with extreme caution since ignition may occur at any time! Stick to the following procedure:

1. Drain the refrigerant
2. Flush the system with inert gas
3. Evacuate
4. Repeat steps 2 to 3 if required
5. Opening the system by cutting or soldering

The system must be flushed with oxygen-free nitrogen in order to guarantee safety. The flushing process must be repeated multiple times if necessary. Do not use compressed air or oxygen for the flushing process! After evacuating, flushing takes place by filling with dried nitrogen until the operating pressure is reached and then the system must be evacuated again. This flushing process must often be repeated until there is no more refrigerant in the system. After the last flushing, the system must be brought to the ambient pressure in order to start work. The flushing process is indispensable when soldering work is required on the piping. Ensure that the vacuum pump outlet is not near an ignition source and continuous ventilation is guaranteed.

■ Filling process

The following requirements for the general specifications must also be fulfilled during the filling process:

- Ensure that no contamination occurs from other refrigerants (residues in the filling equipment).
- Keep the lines as short as possible to minimise the likelihood of residues forming.
- Filling bottles and cylinders must be stood upright.
- Ensure that the system is earthed before filling.
- Label the system with the refrigerant type designation after filling
- Never exceed the maximum fill level.

The system must be checked for leaks (pressure test!) before filling. The system must be checked for leaks once more after filling and before commissioning. Check for leaks again when leaving the work space.

REMKO TK series

■ Labelling when shutting down

If a unit must be taken out of operation and the refrigerant must be disposed of, the unit must be labelled with the date and a signature. Ensure that the note remains attached to the combustible refrigerant.

■ Transportation of units which contain combustible refrigerants

National provisions must be observed.

■ Storing of units which contain combustible refrigerant

National provisions must be observed.

■ Transportation without the original packaging

If the units are transported without the original packaging, they must be packed in such a way that mechanical damage is prevented. The units must be transported upright.

Unit description

The units have been designed for universal and straightforward air dehumidification.

Their compact dimensions allow the unit to be transported and set up with ease.

The units operate in accordance with the condensation principle and are equipped with a hermetically sealed refrigerant system, heat gas defrosting, low-noise and low-maintenance fan and connection cable with plug.

The fully automatic control, the variable hygostat, the condensate container with integrated overflow protection and the connection nozzle for condensate drainage guarantee fault-free continuous operation.

The units conform to the fundamental health and safety requirements of the appropriate EU stipulations.

The units are dependable and offer ease of operation.

The units are used in all locations, where dry air is a must and where economic consequential damage (such as that caused by mould) must be prevented.

The units may be used for the drying and dehumidification of areas such as:

- Living rooms, bedrooms, shower rooms or cellar rooms
- Weekend homes, caravans
- Warehouses, archives laboratories
- Bathrooms, wash rooms and changing rooms etc.
- Cellar rooms, storage rooms

Operating sequence

The units are switched on and off by the Power key.

The fan extracts the moist room air through the intake grill with filter, evaporator and the condenser behind.

Heat is removed from the room air on the cold *evaporator*. The air is then cooled to below dew point. The water vapour contained in the room air is then deposited as condensate or rime on the evaporator fins.

On the *condenser* (heat exchanger), the cold and dehumidified air is warmed up again and discharged back into the room via the outlet grill with a temperature increase of around 5 - 10 °C above the room temperature.

The processed, dry air then re-mixes with the room air. Continuous circulation of the room air through the unit gradually reduces the relative humidity (% RH) in the room to the desired humidity level.

Depending on the room air temperature and the relative humidity, condensed water will drip into the condensate trap and then through the integrated discharge nozzle into the condensate container below either continuously or only during the defrosting phases.

A float is installed inside the condensate container. In the event that the container is full, the float will activate a microswitch which will switch off dehumidification mode.

The units switch off and the "container full" indicator light on the control panel illuminates. This extinguishes again when the empty condensate container is re-inserted.

The units then restart after a switch-on delay of around 3 minutes.

In unattended continuous operation with an external condensate connection, the condensate that occurs is drained continuously via a hose connection.

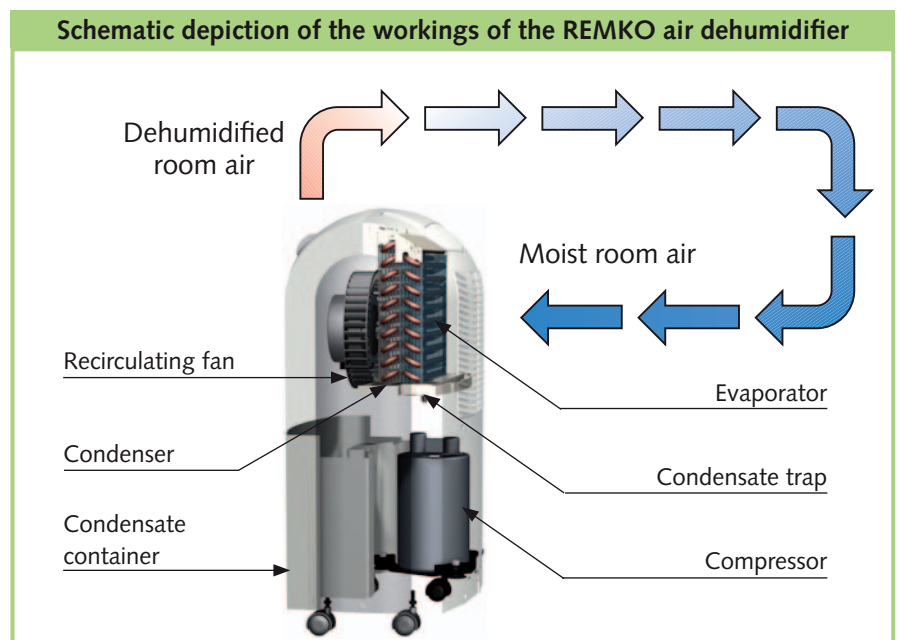

REMKO TK series

Set-up

For the best economic and safe use of the units, the following notes must be followed in full:

- The units must be set up in an upright and level position, to ensure that the condensate can drain freely
- To ensure optimum air circulation, the units should be set up in the centre of the room, where possible
- Ensure that the room air can be sucked in and discharged without hindrances
- Observe a minimum clearance of 50 cm from walls at all times
- Units must never be set up in the immediate vicinity of heaters or other sources of heat
- Air circulation is improved if the unit is set up approx. 1 m above the ground
- The room being dried or dehumidified must be closed to the surrounding atmosphere
- Avoid having opened windows and doors etc., and avoid frequent entry to or exit from the room as much as possible
- The units may not be used in environments containing a great deal of dust or chlorine, or in places with atmospheres containing ammonia
- The output of the unit is entirely dependent on the conditions inside the room, room temperature, relative humidity and observance of the set-up instructions

Electrical wiring

- The units are operated with 230 V/50 Hz alternating current



- The electrical connection is made using a built-in mains cable with earthed safety plug



NOTE

The electrical connection to the units must be made at feedpoints with residual current devices in accordance with VDE 0100, Section 704. When installing the units in extremely damp environments such as laundry rooms, showers etc., the unit must be secured with a residual current device provided by the customer in accordance with the regulations.

- Extensions to the connection cable may only be carried out by authorised electricians, subject to the length of the cable, connected load of the unit and taking into consideration how the unit is used at its location



CAUTION

All cable extensions must only be used in a fully unrolled or reeled off condition.

Schematic depiction of how to set up the REMKO air dehumidifier



Commissioning

Before commissioning the unit or if local requirements dictate, the air-inlet grill and air-outlet grill must be checked for contamination.

NOTE

A contaminated grille or filter must be cleaned or replaced immediately.

Important notes prior to commissioning

- All extensions to the electrical connection must be of a sufficient cable size and must only be used fully rolled out or unrolled
- Never use the mains cable as a pull cord
- After being switched on, the units operate fully-automatically until switched off by the hygrostat or float when the condensate container is full
- The condensate container must be inserted properly
The unit cannot be operated if the condensate container is not inserted properly!
- In order to prevent damage to the condenser, the units are equipped with a mechanism that prevents the compressor being immediately switched back on after it is switched off
The units do not switch back on until a waiting time of around 3 minutes has elapsed!
- If the units work in continuous operation with an external condensate drainage connection, refer to the relevant section

NOTE

In room temperatures below 10 °C and relative humidity below 40 %, economical use of the unit can no longer be guaranteed.

NOTE

Note that the compressor does not switch on until a waiting time of 3 minutes has elapsed.
Restart protection!

Commissioning the units

1. Connect the unit's electrical connection to a properly installed mains socket.

2. Open the air flap on the top of the unit.
3. Use the Power button.

CAUTION

The units are only permitted to be operated with the air flap open in order to prevent overheating.

4. Use the SET key to select the desired humidity level in the installation room

NOTE

The devices can be switched ON and OFF via an external time (accessory) if required.

Control panel

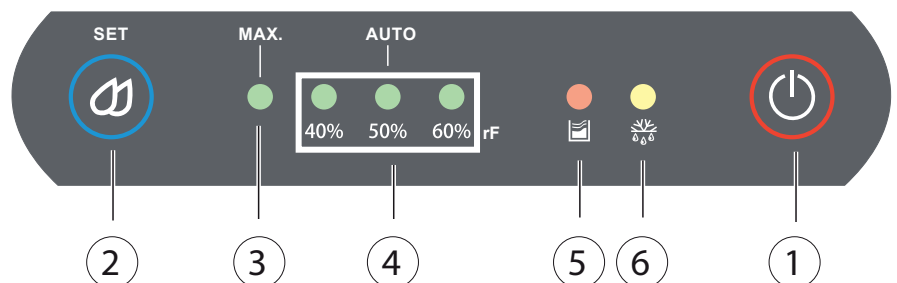

- ① **Power key**
The POWER key switches the unit on and off.
- ② **SET key**
Use the SET key to select the desired humidity in the installation room.
- ③ **„MAX“ status light**
This light indicates that the unit is in continuous operation
- ④ **„AUTO“ status lights**
These lights indicate which humidity level has been set. .
- ⑤ **“Container full” indicator light**
This light indicates that the condensate container is full and must be emptied
- ⑥ **“Defrost mode” indicator light**
This light indicates that the automatic defrost system that is integrated in the unit has switched on the defrost cycle

REMKO TK series

Adjusting units/moisture

The unit's dehumidification power is entirely dependent on the conditions inside the room, the room temperature, the relative humidity and observance of the notes in the "Setting up" chapter.



NOTE

The maximum possible dehumidification power is only obtained when the air flap is opened completely.

The higher the room temperature and relative air humidity, the higher the dehumidification power.

A relative humidity of around 45 to 60 % is sufficient in living rooms. The air humidity should not exceed 40 to 45 % in warehouses, archives, etc.

The set target value can be read from the "AUTO" and "MAX." Status lights.

In automatic mode ("AUTO") the device works fully automatically and switches off automatically when the setpoint has been reached.

In continuous operation ("MAX.") The device works without interruption and ensures maximum dehumidification.

The setpoint is changed by pressing the SET button. The LED display changes from right to left.

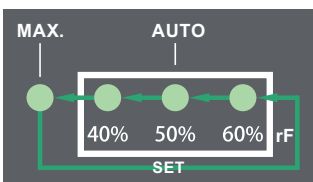

Adjusting the discharge direction

The dehumidified room air is discharged on the top of the unit. The pivotable air flap [S] is used to adjust the discharge direction.



Press the air flap's rear surface [D] to open it.

The front folds upwards. The air direction can be adjusted infinitely.

The following notes must also be observed in full:

- If possible, open the air flap completely to direct the air flow upwards
 - Ensure that the air can discharge without hindrances
- This is the only way to guarantee optimum unit operation!**
- Ensure that sensitive objects such as house plants are not placed directly in the air flow emerging from the unit

Automatic defrost system

The moisture contained in the room air condenses when cooling and coats the evaporator fins with rime or ice depending on the air temperature and the relative humidity (% RH).

The automatic defrost system that is integrated in the unit switches the defrost cycle on if required.

The rime or ice that has accumulated on the exchanger surfaces is defrosted using heat gas as required.

This defrosting method is particularly fast and effective, and guarantees high dehumidification performance.

Dehumidification mode is only paused for a short time during the defrost phase.

The "Defrost mode" indicator light indicates that the defrost cycle is running.



NOTE

If the room temperature is sufficiently high, the surface of the fins will not be cold enough for rime formation to occur, rendering defrosting unnecessary. Therefore, the air dehumidifier works economically.



NOTE

The built-in hygrometer is not a calibrated measuring instrument and is located inside the unit. The averaged air humidity in the installation room may deviate from the set value under certain circumstances.

Emptying the condensate container

The integrated condensate container must be emptied from time to time.

Dehumidification mode is switched off if the condensate container is full.

The "Container full" indicator light indicates that the unit has switched off.

1. Pull the full container forwards and out carefully.

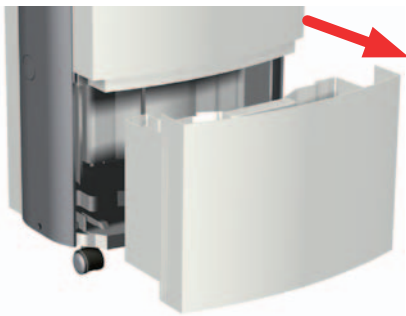

2. Pour the water into a drain.

NOTE

After being emptied, the condensate container incl. float must be checked for damage, contamination etc.

3. Re-insert the emptied container carefully into the unit.

The "Container full" indicator light extinguishes and the unit continues to run automatically.

NOTE

The unit can only be started once the condensate container has been inserted correctly.

Continuous operation with external condensate outlet

The units are equipped with a special connection nozzle on the left side.

A standard 1/2" water hose can be connected to this.

CAUTION

There is no unit overflow protection in this variant.

1. To do this, use a suitable tool to break the cover [F] out of the side wall.

Only required for the first connection!



2. Connect a sufficiently long and suitable drain hose to the connection nozzle that is now exposed.

In unattended permanent operating mode, the condensate should preferably be drained into a lower-level drain.

If using an external collection container (pan, bucket, etc.), the unit must be placed at a correct height.

CAUTION

Ensure that the drainage hose is placed at an incline to the drain to allow the condensate to drain without hindrance!

Leakage control device

The unit is equipped with a leakage control device to prevent damage in the event of refrigerant loss.

If the unit detects a leak, the compressor is switched off. The fan continues to operate without interruption in order to prevent an accumulation of refrigerant.

HINWEIS

By switching the compressor off and on again, the unit initially continues to run in normal operation until the leakage control device switches the compressor off again.

ACHTUNG

A lack of refrigerant can cause damage to the unit. If a lack of refrigerant is detected (continuous fan operation when the compressor is not running), the unit must be taken out of operation immediately! Work on the refrigerant system and on the electrical equipment must only be conducted by a specially authorised specialist! The leakage control device must not be viewed as a replacement for maintenance work and damage checks!

REMKO TK series

Shutdown

Use the POWER key to switch the unit off.

If the units are inactive for longer periods, disconnect them from the mains power supply.



Empty the condensate container completely and dry with a clean cloth.

Beware of dripping condensate!

The units must be cleaned and dried completely before storing.

When storing the unit, cover with a plastic sheet/foil if necessary and store in an upright position in a sheltered and dry location.

The units are only permitted to be stored upright in a suitable storage location that is protected against dust and direct sunlight.

Unit transport

The units are equipped with four foot rollers and an additional handle for easy and convenient transport.

- Before each change of location, switch off the unit and remove the power plug from the mains socket
- Empty the condensate container completely



NOTE

*Beware of dripping condensate.
After switching off the units, the evaporator may continue to defrost under the influence of the ambient temperature.*

- If moisture residual remains on the evaporator or water remains in the condensate container, the units must only be transported in an upright position
- The transport rollers are only suitable for use on level and smooth ground
- The devices must be carried when transporting on rough terrain or uneven surfaces



CAUTION

The mains cable must never be used as a pull cord or fixing device.

Care and maintenance

NOTE

Regular care and maintenance is fundamental to a long service life and fault-free operation of the unit.

All moving parts have a low-maintenance permanent coat of lubricant. The entire refrigerant system is designed as a maintenance-free, hermetically sealed system and may only be repaired by a specialist.

CAUTION

Before undertaking any work on the units, the power plug must be removed from the mains socket.

- Observe the regular care and maintenance intervals
- In accordance with the operating conditions, the units must, if necessary, be checked at least yearly by a specialist to ensure that they are in a condition that is safe to use
- Only clean the units with a dry or damp cloth
Do not use a water jet!
- Never use abrasive or solvent-based cleaners
- Use only suitable cleaners, even for heavy contamination
- Check the inlet and outlet grille for contamination on a regular basis
Clean or replace if required!

Cleaning the condenser and evaporator

The unit housing must be opened to allow the inside of the unit to be cleaned and to provide access to electrical components.

NOTE

Adjustment and maintenance work may only be carried out by authorised and qualified technicians.

- Clean the condenser and the evaporator by blowing, vacuuming or using a soft brush
Do not use water jets!

NOTE

When cleaning the exchanger, particular care must be taken because the fine aluminium fins bend very easily.

- Clean the interior surfaces on the units, the condensate traps with hose connection, the fan and the fan housing carefully
- Check all unit components for damage and repair if necessary
- Carefully refit all parts that were removed in reverse order

CAUTION

An electrical safety check must be carried out in accordance with VDE 0701 after any work on the units.

REMKO TK series

Filter cleaning

To prevent damage to the unit, it is equipped with an intake grill with integrated air filter.

In order to prevent power losses or unit faults, the intake grill with filter must be inspected as required, but every 2 weeks at the latest, and cleaned if necessary.

1. Use the hygrostat to switch the unit off.
2. Remove the power plug from the mains socket.
3. Reach into the recess [G], push the intake grill backwards slightly and pull it upwards and out of the unit's rear wall.



4. Remove the filter that is behind the intake grill.

CAUTION

The units are not permitted to be operated without the intake grill and air filter fitted!

5. Clean the air filter with lukewarm water or a vacuum cleaner.



6. Heavier contamination may be remedied by rinsing the filter in a lukewarm (max. 40 °C) soap solution. Finally, always rinse the filter carefully with clear water and allow to dry!



7. Also check the intake grill for contamination and clean if necessary.
8. Before refitting grill and filter, ensure that they are fully dry and that no damage has been sustained.

NOTE

Heavily contaminated or damaged air filters must be replaced with new parts. Only original spare parts may be used.

Troubleshooting

The units are manufactured using state-of-the-art production methods and tested several times to verify their correct function.

However, if a functional fault should occur, the unit should first be checked in accordance with the following list.

NOTE

Adjustment and maintenance work may only be carried out by authorised and qualified technicians.

The unit does not start:

- Check the hygrostat's setting
The set value must be lower than the relative humidity in the installation room!
- Check the power supply and the power fuse provided by the customer 230V/1~/50 Hz
- Check the power plug and the cable for damage
- Check the condensate tank's fill level and seating
The "Container full" indicator light must not be illuminated!
- Check that the microswitch [MS] on the condensate container is functioning
- Check that the inlet and outlet are free
Overheating!
- Check the fuse on the control board



The unit runs but condensate is not formed:

- Check the room temperature
The operating range of the unit is between 6 °C and 32 °C
- Check the humidity of the air
Min. 40 % RH required
- Check the intake grill and air filter for contamination
Clean or replace if required!
- Have the heat exchanger fins checked for contamination
This work requires the unit to be opened and must therefore only be carried out by an authorised specialist company!
- Check that the compressor is functioning correctly. If it is not operational while the fan is running, then the leakage control device has disabled the compressor. Check the refrigerant system for leaks.

The unit is loud or condensate runs out:

- Check whether the unit is on a stable and even base
- Check whether the unit is standing upright and stably
- Have the condensate trap or the connection nozzles checked to see whether there are dirt deposits on them
This work requires the unit to be opened and must therefore only be carried out by an authorised specialist company!

Note on refrigerants

The units work with environmentally-friendly and ozone-neutral R290 refrigerant. The mixture of refrigerant and oil within the unit must be disposed of properly in accordance with the statutory or locally-applicable regulations.

NOTE

If the unit fails to function correctly after the checks have been carried out, contact an authorised specialist.

CAUTION

Work on the refrigerant system and on the electrical equipment must only be conducted by a specially-authorized specialist!

Electrical wiring diagram

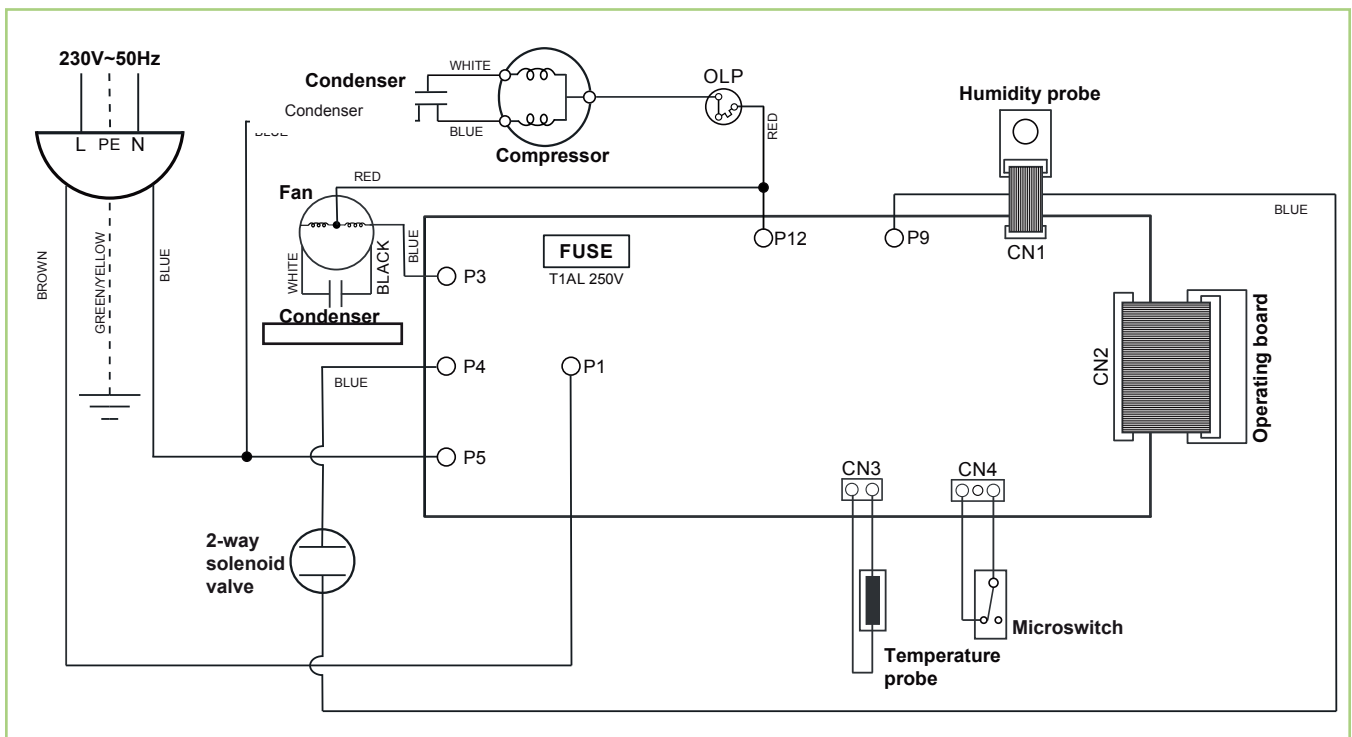

REMKO TK series

Intended use

The units are designed exclusively for drying and dehumidification purposes on the basis of their structural design and equipment. The units must not be used for any other purpose.

The units are only permitted to be operated by people with the relevant training and understanding of how to handle them.

The manufacturer shall not be liable for damage resulting from non-observance of the manufacturer's specifications, the respective local legal requirements or from arbitrary alterations to the units.

NOTE

Operation other than the types listed in this operating manual is prohibited. With non-observance, any manufacturer liability or guarantee claims are voided.

CAUTION

*Copyright
The redistribution, even in part, or the use of this documentation for purposes other than intended is prohibited without the written authorisation of
REMKO GmbH & Co. KG.*

Customer service and Guarantee

As a prerequisite for any guarantee claims to be considered, it is essential that the ordering party or its representative complete and return the **"Certificate of guarantee"** to REMKO GmbH & Co. KG at the time when the units are purchased and commissioned.

The units were tested at the factory several times to verify their correct function. However, if malfunctions should arise that cannot be remedied by the operator with the assistance of the troubleshooting section, please contact your specialist dealer or contractual partner.

NOTE

Adjustment and maintenance work may only be carried out by authorised and qualified technicians.

Important information concerning recycling

The units are operated with environmentally-friendly and ozone-neutral R290 refrigerant.

The mixture of refrigerant and oil within the unit must be disposed of properly in accordance with the statutory or locally-applicable regulations.



Environmental protection and recycling

Disposal of packaging

When disposing of packaging material, please consider our environment.

Our units are carefully packed and delivered in stable cardboard transport packaging and, if applicable, on a wooden pallet. The packaging materials are environmentally-friendly and can be recycled.

By recycling packaging materials, you make a valuable contribution to the reduction of waste and conservation of raw materials.

Therefore, only dispose of packaging material at appropriate collection points.

Disposal of the old unit

At the end of its service life, this unit is not permitted to be disposed of in household waste. It must be taken to a special collection point for electrical and electronic units. The materials are recyclable according to their labels. By reusing, recycling substances or other forms of recycling for used devices, you make a valuable contribution to protecting our environment.

Please contact your local authority for information on the disposal facility responsible.



Exploded view of the unit

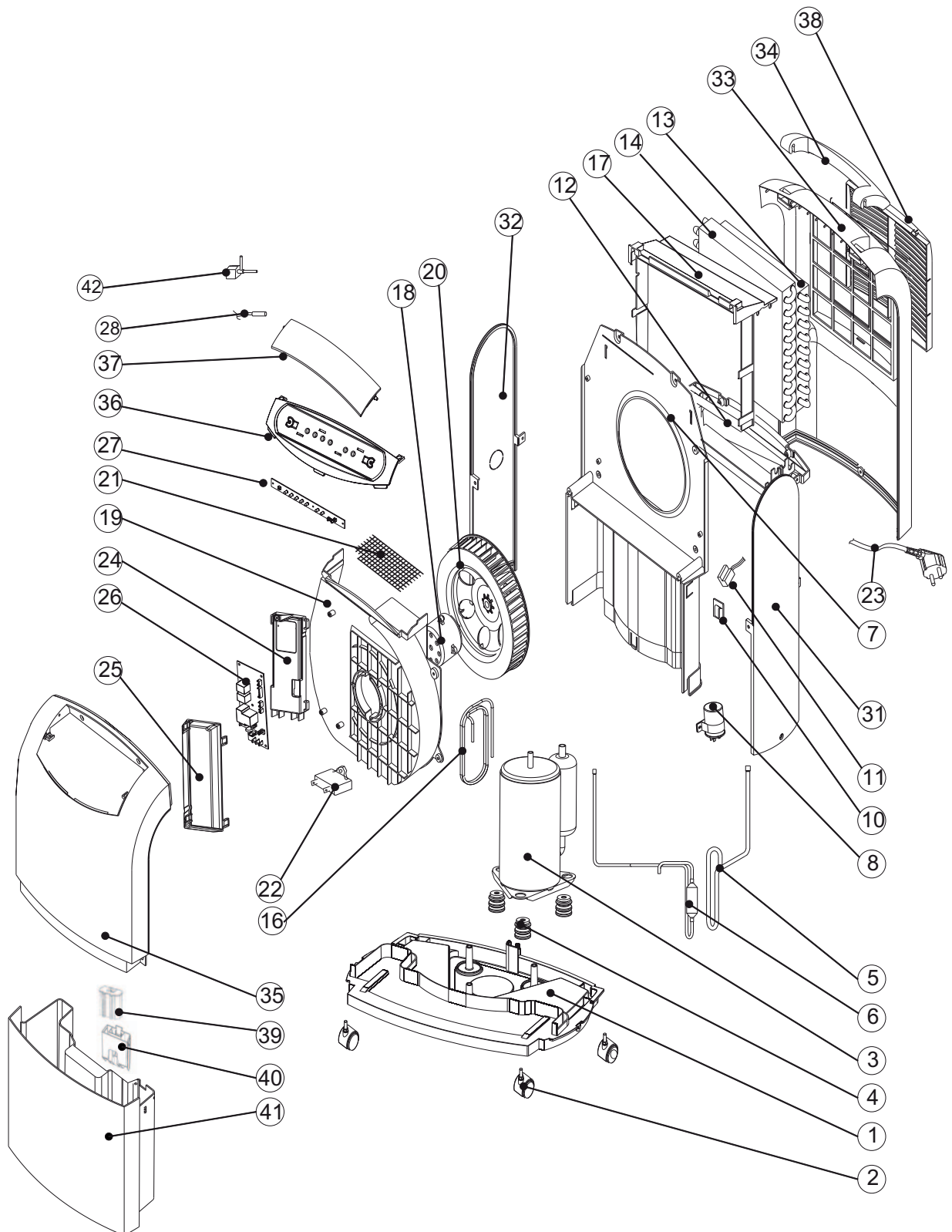

We reserve the right to modify the dimensions and design as part of the ongoing technical development process.

REMKO TK series

Spare parts list

No.	Designation	EDP no.
1	Base plate	
2	Conveyor rollers	
3	Compressor, cpl.	
4	Vibration dampers	
5	Suction pipe	
6	High pressure line	
7	Centre wall	
8	Condenser (compressor)	
11	Microswitch	
12	Condensate trap	
13	Fin vaporiser	
14	Fin condenser	
16	Capillary	
17	Board housing	
18	Support plate	
19	Fan housing	
20	Fan wheel	On request by providing the serial number
21	Protection grid	
22	Condenser (fan motor)	
23	Mains cable with plug	
24	Board housing	
25	Cover (board housing)	
26	Control board	
27	Control panel	
28	Antifreeze sensor	
31	Side covering, right	
32	Side covering, left	
33	Back wall	
34	Transport handle	
35	Front wall	
36	Control panel	
37	Air flap	
38	Intake grill	
39	Float, cpl.	
40	Float housing	
41	Condensate container cpl.	
42	Solenoid valve, cpl.	

When ordering replacement parts, please always state the EDP no. and unit number (see name plate)!

Maintenance protocol

Unit type: Unit number:

	1	2	3	4	5	6	7	8	9	10	11	12	13	14	15	16	17	18	19	20
Unit cleaned - outside -																				
Unit cleaned - inside -																				
Fan blade cleaned																				
Fan housing cleaned																				
Condenser cleaned																				
Evaporator cleaned																				
Fan function checked																				
Air-inlet grid with filter cleaned																				
Unit checked for damage																				
Safety devices checked																				
All fastening screws checked																				
Electrical safety check																				
Test run																				

Comments:

1. Date: Signature	2. Date: Signature	3. Date: Signature	4. Date: Signature	5. Date: Signature
6. Date: Signature	7. Date: Signature	8. Date: Signature	9. Date: Signature	10. Date: Signature
11. Date: Signature	12. Date: Signature	13. Date: Signature	14. Date: Signature	15. Date: Signature
16. Date: Signature	17. Date: Signature	18. Date: Signature	19. Date: Signature	20. Date: Signature

Unit to be maintained only by authorised specialists in accordance with the statutory regulations.

REMKO TK series

Technical data

Series		TK 300
Operating range, temperature	°C	6 to 32
Operating range, humidity	% RH	40 to 100
Dehumidification capacity max.	l/day	32
At 30 °C/80 % RH	l/day	30
At 20 °C/70 % RH	l/day	17
At 15 °C/60 % RH	l/day	10
Max. airflow volume	m ³ /h	190
Condensate container capacity	Litres	5
Refrigerant	---	R290
Refrigerant quantity	g	122
Min. room size	m ²	6
GWP		3
CO ₂ equivalence		0.00
Power supply	V/Ph/Hz	230/1~/50
Fuse		T1AL 250V
Max. rated current consumption	A	2.80
Max. power consumption	kW	0,600
At 20 °C/70 % RH	kW	0,440
At 15 °C/60 % RH	kW	0,400
Max. specific energy consumption (SEC)	kWh/l	0,480
At 20 °C/70 % RH	kWh/l	0,695
At 15 °C/60 % RH	kWh/l	1,143
Sound pressure level L _{pA} 1m	dB (A)	51
Depth	mm	274
Width	mm	390
Height	mm	612
Weight	kg	17
EDP no.		1610305

We reserve the right to modify the dimensions and design as part of the ongoing technical development process.

REMKO QUALITY WITH SYSTEMS

Air-Conditioning | Heating | New Energies

The User's manual and specific instruction related to the safe operation of this appliance are also available in website.

REMKO GmbH & Co. KG
Klima- und Wärmetechnik

Telephone +49 (0) 5232 606-0
Telefax +49 (0) 5232 606-260

Hotline within Germany
+49 (0) 5232 606-0

Im Seelenkamp 12
32791 Lage

E-mail info@remko.de
URL www.remko.de

Hotline International
+49 (0) 5232 606-130

