

Part No. 060390-10, Rev. D
September 2016

OmniSwitch 6860/6860E

Hardware Users Guide



enterprise.alcatel-lucent.com

This user guide documents OmniSwitch 6860/6860E hardware, including chassis and associated components. The specifications described in this guide are subject to change without notice.

enterprise.alcatel-lucent.com

Alcatel-Lucent and the Alcatel-Lucent Enterprise logo are trademarks of Alcatel-Lucent. To view other trademarks used by affiliated companies of ALE Holding, visit: enterprise.alcatel-lucent.com/trademarks. All other trademarks are the property of their respective owners. The information presented is subject to change without notice. Neither ALE Holding nor any of its affiliates assumes any responsibility for inaccuracies contained herein. (July 2015)



26801 West Agoura Road
Calabasas, CA 91301
(818) 880-3500 FAX (818) 880-3505

Service & Support Contact Information

North America: 800-995-2696
Latin America: 877-919-9526
EMEA: +800 00200100 (Toll Free) or +1(650)385-2193
Asia Pacific: +65 6240 8484
Web: support.esd.alcatel-lucent.com
Email: ebg_global_supportcenter@al-enterprise.com

Contents

	About This Guide	ix
	Supported Platforms	ix
	Who Should Read this Manual?	ix
	When Should I Read this Manual?	ix
	What is in this Manual?	x
	What is Not in this Manual?	x
	How is the Information Organized?	x
	Documentation Roadmap	xi
	Related Documentation	xiii
	Technical Support	xiv
Chapter 1	OmniSwitch 6860	1-1
	OmniSwitch 6860 Availability Features	1-3
	Power Supply Redundancy	1-3
	Hot-Swapping	1-3
	Hardware Monitoring	1-4
Chapter 2	Getting Started	2-1
	Installing the Hardware	2-1
	Items Required	2-1
	Site Preparation	2-1
	Environmental Requirements	2-1
	Electrical Requirements	2-1
	Electrical Surge Warning	2-2
	Unpacking and Installing the Switch	2-3
	Items Included	2-3
	Weight Considerations	2-3
	Airflow Considerations	2-4
	Mounting the Switch	2-4
	Connections and Cabling	2-5
	Network Cable Installation Warning	2-5
	Serial Connection to the Console Port	2-5
	Serial Connection Default Settings	2-5
	Ethernet Management Port (EMP) Cable Requirements	2-5
	Booting the Switch	2-6
	Component LEDs	2-6

Your First Login Session	2-7
Logging In to the Switch	2-7
Setting IP Address Information for the EMP	2-8
Unlocking Session Types	2-9
Changing the Login Password	2-9
Setting the System Time Zone	2-10
Setting the Date and Time	2-10
Setting Optional Parameters	2-10
Specifying an Administrative Contact	2-10
Specifying a System Name	2-10
Specifying the Switch's Location	2-10
Viewing Your Changes	2-11
Saving Your Changes	2-11
Chapter 3	
Chassis and Power Supplies	3-1
OmniSwitch 6860 Chassis Details	3-2
Basic Models - Non-PoE	3-2
OS6860-24 Front Panel	3-2
OS6860-24 Rear Panel	3-2
OS6860-24 Chassis Specifications	3-3
OS6860-48 Front Panel	3-4
OS6860-48 Rear Panel	3-4
OS6860-48 Chassis Specifications	3-5
Basic Models - PoE	3-6
OS6860-P24 Front Panel	3-6
OS6860-P24 Rear Panel	3-6
OS6860-P24 Chassis Specifications	3-7
OS6860-P48 Front Panel	3-8
OS6860-P48 Rear Panel	3-8
OS6860-P48 Chassis Specifications	3-9
Enhanced Models - Non-PoE	3-10
OS6860E-24 Front Panel	3-10
OS6860E-24 Rear Panel	3-10
OS6860E-24 Chassis Specifications	3-11
OS6860E-48 Front Panel	3-12
OS6860E-48 Rear Panel	3-12
OS6860E-48 Chassis Specifications	3-13
OS6860E-U28 Front Panel	3-14
OS6860E-U28 Rear Panel	3-14
OS6860E-U28 Chassis Specifications	3-15
Enhanced Models - PoE	3-16
OS6860E-P24 Front Panel	3-16
OS6860E-P24 Rear Panel	3-16
OS6860E-P24 Chassis Specifications	3-17
OS6860E-P48 Front Panel	3-18
OS6860E-P48 Rear Panel	3-18
OS6860E-P48 Chassis Specifications	3-19
Chassis Status LEDs	3-19

Mounting the Switch	3-21
General Mounting Recommendations	3-21
Airflow Recommendations	3-22
Blank Cover Panels	3-23
Installing Blank Cover Panels	3-23
Rack-Mounting	3-24
Installing Rack Mount Flanges	3-24
Installing the Chassis In the Rack	3-26
Standalone (Non-Rack Mounted) Installations	3-27
Power Supplies	3-28
Dying Gasp	3-29
Scenarios	3-29
SNMP Trap	3-29
Syslog Message	3-29
OS6860-BP 150W Power Supply	3-30
OS6860-BP LED States	3-30
OS6860-BP-D 150W DC Power Supply	3-31
OS6860-BP-D LED States	3-31
OS6860-BP-PH 600W Power Supply	3-32
OS6860-BP-PH LED States	3-32
OS6860-BP-PX 920W Power Supply	3-33
OS6860-BP-PX LED States	3-33
DC Power Supply Connections	3-34
Connecting a DC Cable Harness to the Chassis Power Supply	3-34
Connecting a DC Cable Harness to the DC Power Source	3-34
Installing Power Supplies	3-35
Removing Power Supplies	3-37
Grounding the Chassis	3-39
OS6860 FANTRAY NONPOE Fan Tray	3-40
OS6860 FANTRAY NONPOE LED States	3-40
Monitoring Chassis Components	3-41
Viewing Chassis Slot Information	3-41
Monitoring Chassis Temperature	3-41
Temperature Errors	3-42

Chapter 4	Managing Power over Ethernet (PoE)	4-1
	In This Chapter	4-2
	Power over Ethernet Specifications	4-3
	Viewing Power Supply Status	4-3
	Viewing PoE Status	4-4
	Power over Ethernet Defaults	4-4
	Understanding and Modifying the Default Settings	4-5
	PoE Class Detection	4-5
	PoE Operational Status	4-5
	Configuring the Total Power Available to a Port	4-6
	Configuring the Total Power Available to a slot	4-6
	Setting Port Priority Levels	4-7
	Setting the Capacitor Detection Method	4-7
	Understanding Priority Disconnect	4-8
	Setting Priority Disconnect Status	4-8
	Disabling Priority Disconnect	4-8
	Enabling Priority Disconnect	4-8
	Priority Disconnect is Enabled; Same Priority Level on All PD	4-9
	Priority Disconnect is Enabled; Incoming PD Port has Highest Priority Level	4-9
	Priority Disconnect is Enabled; Incoming PD Port has Lowest Priority Level	4-9
	Priority Disconnect is Disabled	4-10
	Monitoring Power over Ethernet via CLI	4-11
Appendix A	Regulatory Compliance and Safety Information	A-1
	Declaration of Conformity: CE Mark	A-1
	Waste Electrical and Electronic Equipment (WEEE) Statement	A-1
	China RoHS: Hazardous Substance Table	A-2
	California Proposition 65 Warning	A-2
	Standards Compliance	A-3
	FCC Class A, Part 15	A-5
	Canada Class A Statement	A-5
	JATE	A-5
	CISPR22 Class A warning	A-5
	Korea Emissions Statement	A-6
	VCCI	A-6
	Class A Warning for Taiwan and Other Chinese Markets	A-6
	Class 1M Laser Warning	A-6
	Network Cable Installation Warning	A-6
	Translated Safety Warnings	A-7
	Blank Panels Warning	A-7
	Electrical Storm Warning	A-7
	Installation Warning	A-7
	Invisible Laser Radiation Warning	A-8
	Operating Voltage Warning	A-8
	Power Disconnection Warning	A-8
	Proper Earthing Requirement Warning	A-9

DC Power Supply Connection Warning	A-9
Read Important Safety Information Warning	A-10
Restricted Access Location Warning	A-10
Wrist Strap Warning	A-10
Instrucciones de seguridad en español	A-11
Advertencia sobre el levantamiento del chasis	A-11
Advertencia de las tapaderas en blanco	A-11
Advertencia en caso de tormenta eléctrica	A-11
Advertencia de instalación	A-11
Advertencia de radiación láser invisible	A-11
Advertencia de la batería de litio	A-11
Advertencia sobre la tensión de operación	A-11
Advertencia sobre la desconexión de la fuente	A-11
Advertencia sobre una apropiada conexión a tierra	A-12
Leer “información importante de seguridad”	A-12
Advertencia de acceso restringido	A-12
Advertencia de pulsera antiestática	A-12
Clase de seguridad	A-12
Advertencia de fuentes de poder	A-12

About This Guide

This *OmniSwitch 6860 Hardware Users Guide* describes OmniSwitch 6860 switch components and basic switch hardware procedures.

Supported Platforms

The information in this guide applies only to OmniSwitch 6860 switches.

Who Should Read this Manual?

The audience for this users guide is network administrators and IT support personnel who need to configure, maintain, and monitor switches and routers in a live network. However, anyone wishing to gain knowledge of OmniSwitch 6860 hardware will benefit from the material in this guide.

When Should I Read this Manual?

Read this guide as soon as you are ready to familiarize yourself with your switch hardware components.

You should already be familiar with the very basics of the switch hardware, such as module LEDs and component installation procedures. This manual will help you understand your switch hardware in greater depth.

What is in this Manual?

This users guide includes the following hardware-related information:

- Descriptions of “Availability” features.
- Technical specifications for the chassis, power supplies and modules.
- Power supply requirements.
- The dynamics of chassis airflow, including detailed illustrations of proper and improper airflow configurations.
- Hot-swapping power supplies and modules.
- Installation and removal procedures for power supplies and modules.
- Detailed illustrations and LED descriptions for chassis, network and power supply operability.
- Hardware-related Command Line Interface (CLI) commands.

What is Not in this Manual?

The descriptive and procedural information in this manual focuses on switch hardware. It includes information on some CLI commands that pertain directly to hardware configuration, but it is not intended as a software users guide. There are several OmniSwitch users guides that focus on switch software configuration. Consult those guides for detailed information and examples for configuring your switch software to operate in a live network environment. See [“Documentation Roadmap” on page -xi](#) and [“Related Documentation” on page -xiii](#) for further information on software configuration guides available for your switch.

How is the Information Organized?

Each chapter in this guide focuses on a specific hardware component or a set of hardware components. All descriptive, technical specification, and procedural information for a hardware component can be found in the chapter dedicated to that component.

Documentation Roadmap

The OmniSwitch user documentation suite was designed to supply you with information at several critical junctures of the configuration process. The following section outlines a roadmap of the manuals that will help you at each stage of the configuration process. Under each stage, we point you to the manual or manuals that will be most helpful to you.

Stage 1: Using the Switch for the First Time

Pertinent Documentation: *OmniSwitch 6860/6860E Getting Started Information*
OmniSwitch AOS Release 8 Release Notes

A “Getting Started” chapter is included in the *OmniSwitch 6860 Hardware Users Guide*. This chapter provides all the information you need to get your switch up and running the first time. It also includes succinct overview information on fundamental aspects of the switch.

At this time you should also familiarize yourself with the Release Notes that accompanied your switch. This document includes important information on feature limitations that are not included in other user guides.

Stage 2: Gaining Familiarity with Basic Switch Functions

Pertinent Documentation: *OmniSwitch 6860/6860E Hardware Users Guide*
OmniSwitch AOS Release 8 Switch Management Guide

Once you have your switch up and running, you will want to begin investigating basic aspects of its hardware and software. Information about switch hardware is provided in the *OmniSwitch 6860 Hardware Guide*. This guide provides specifications, illustrations, and descriptions of all hardware components. It also includes steps for common procedures, such as removing and installing switch components.

This guide is the primary users guide for the basic software features on a single switch. This guide contains information on the switch directory structure, basic file and directory utilities, switch access security, SNMP, and web-based management. It is recommended that you read this guide before connecting your switch to the network.

Stage 3: Integrating the Switch Into a Network

Pertinent Documentation: *OmniSwitch AOS Release 8 Network Configuration Guide*
OmniSwitch AOS Release 8 Advanced Routing Configuration Guide

When you are ready to connect your switch to the network, you will need to learn how the OmniSwitch implements fundamental software features, such as 802.1Q, VLANs, Spanning Tree, and network routing protocols. The *Network Configuration Guide* guide contains overview information, procedures, and examples on how standard networking technologies are configured on the OmniSwitch.

The *Advanced Routing Guide* includes configuration information for networks using advanced routing technologies (OSPF and BGP) and multicast routing protocols (DVMRP and PIM-SM).

Anytime

The *OmniSwitch CLI Reference Guide* contains comprehensive information on all CLI commands supported by the switch. This guide includes syntax, default, usage, example, related CLI command, and CLI-to-MIB variable mapping information for all CLI commands supported by the switch. This guide can be consulted anytime during the configuration process to find detailed and specific information on each CLI command.

Related Documentation

The following are the titles and descriptions of all the OmniSwitch 6860 user manuals:

- *OmniSwitch 6860/6860E Hardware Users Guide*

Complete technical specifications and procedures for all OmniSwitch 6860 chassis, power supplies, fans, and Network Interface (NI) modules.
- *OmniSwitch CLI Reference Guide*

Complete reference to all CLI commands supported on the OmniSwitch. Includes syntax definitions, default values, examples, usage guidelines and CLI-to-MIB variable mappings.
- *OmniSwitch AOS Release 8 Switch Management Guide*

Includes procedures for readying an individual switch for integration into a network. Topics include the software directory architecture, image rollback protections, authenticated switch access, managing switch files, system configuration, using SNMP, and using web management software (WebView).
- *OmniSwitch AOS Release 8 Network Configuration Guide*

Includes network configuration procedures and descriptive information on all the major software features and protocols included in the base software package. Chapters cover Layer 2 information (Ethernet and VLAN configuration), Layer 3 information (routing protocols, such as RIP and IPX), security options (authenticated VLANs), Quality of Service (QoS), link aggregation, and server load balancing.
- *OmniSwitch AOS Release 8 Advanced Routing Configuration Guide*

Includes network configuration procedures and descriptive information on all the software features and protocols included in the advanced routing software package. Chapters cover multicast routing (DVMRP and PIM-SM), Open Shortest Path First (OSPF), and Border Gateway Protocol (BGP).
- *OmniSwitch Transceivers Guide*

Includes SFP and XFP transceiver specifications and product compatibility information.
- *Technical Tips, Field Notices*

Includes information published by Alcatel-Lucent's Customer Support group.
- *Release Notes*

Includes critical Open Problem Reports, feature exceptions, and other important information on the features supported in the current release and any limitations to their support.

Technical Support

An Alcatel-Lucent service agreement brings your company the assurance of 7x24 no-excuses technical support. You'll also receive regular software updates to maintain and maximize your Alcatel-Lucent product's features and functionality and on-site hardware replacement through our global network of highly qualified service delivery partners.

With 24-hour access to Alcatel-Lucent's Service and Support web page, you'll be able to view and update any case (open or closed) that you have reported to Alcatel-Lucent's technical support, open a new case or access helpful release notes, technical bulletins, and manuals.

Access additional information on Alcatel-Lucent's Service Programs:

Web: service.esd.alcatel-lucent.com

Phone: 1-800-995-2696

Email: esd.support@alcatel-lucent.com

1 OmniSwitch 6860

Refer to the information below for OmniSwitch 6860 (OS6860) models and components.

Model Number	Description
OS6860-24	Fixed-configuration chassis in a 1U form factor with 24 10/100/1000 Base-T ports, four fixed SFP+ (1G/10G) ports and two 20G Virtual Chassis link ports.
OS6860-P24	Fixed-configuration chassis in a 1U form factor with 24 10/100/1000 Base-T PoE ports, four fixed SFP+ (1G/10G) ports and two 20G Virtual Chassis link ports.
OS6860-48	Fixed-configuration chassis in a 1U form factor with 48 10/100/1000 Base-T ports, four fixed SFP+ (1G/10G) ports and two 20G Virtual Chassis link ports.
OS6860-P48	Fixed-configuration chassis in a 1U form factor with 48 10/100/1000 Base-T PoE ports, four fixed SFP+ (1G/10G) ports and two 20G Virtual Chassis link ports.
OS6860E-24	Fixed-configuration chassis in a 1U form factor with 24 10/100/1000 Base-T ports, four fixed SFP+ (1G/10G) ports and two 20G virtual Chassis link ports. Includes a built-in co-processor for Enhanced network services.
OS6860E-P24	Fixed-configuration chassis in a 1U form factor with 24 10/100/1000 Base-T PoE ports, four fixed SFP+ (1G/10G) ports and two 20G Virtual Chassis link ports. Includes a built-in co-processor for Enhanced network services.
OS6860E-48	Fixed-configuration chassis in a 1U form factor with 48 10/100/1000 Base-T ports, four fixed SFP+ (1G/10G) ports and two 20G Virtual Chassis link ports. Includes a built-in co-processor for Enhanced network services.
OS6860E-P48	Fixed-configuration chassis in a 1U form factor with 48 10/100/1000 Base-T PoE ports, four fixed SFP+ (1G/10G) ports and two 20G Virtual Chassis link ports. Includes a built-in co-processor for Enhanced network services.
OS6860E-U28	Fixed-configuration chassis in a 1U form factor with 28 ports supporting 1000Base-X and 100Base-FX, four fixed SFP+ (1G/10G) ports and two 20G Virtual Chassis link ports. Includes a built-in co-processor for Enhanced network services.

Additional Chassis Components and Connectors

The OS6860 chassis provides two bays for 1+1 redundant hot-swappable power supplies. (Non-PoE models allow the installation of a single optional fan tray in place of one 150W power supply.)

All models include one console connector (for use with Micro USB-to-USB cable, included); one USB connector (for use with Alcatel-Lucent flash drive or Bluetooth dongle, not included); and one RS-232 connector.

Enhanced models, including OS6860E-24, OS6860E-48, OS6860E-48, OS6860E-P48 and OS6860E-U28 provide one Ethernet Management Port (EMP) located on the rear panel for out-of-band management.

For detailed information on the chassis, including front and rear panel connectors and components, refer to [Chapter 3, “Chassis and Power Supplies.”](#)

For information on console, USB and Bluetooth connections and cable requirements, refer to the *OmniSwitch 6860/OS6860E Switch Management Guide*.

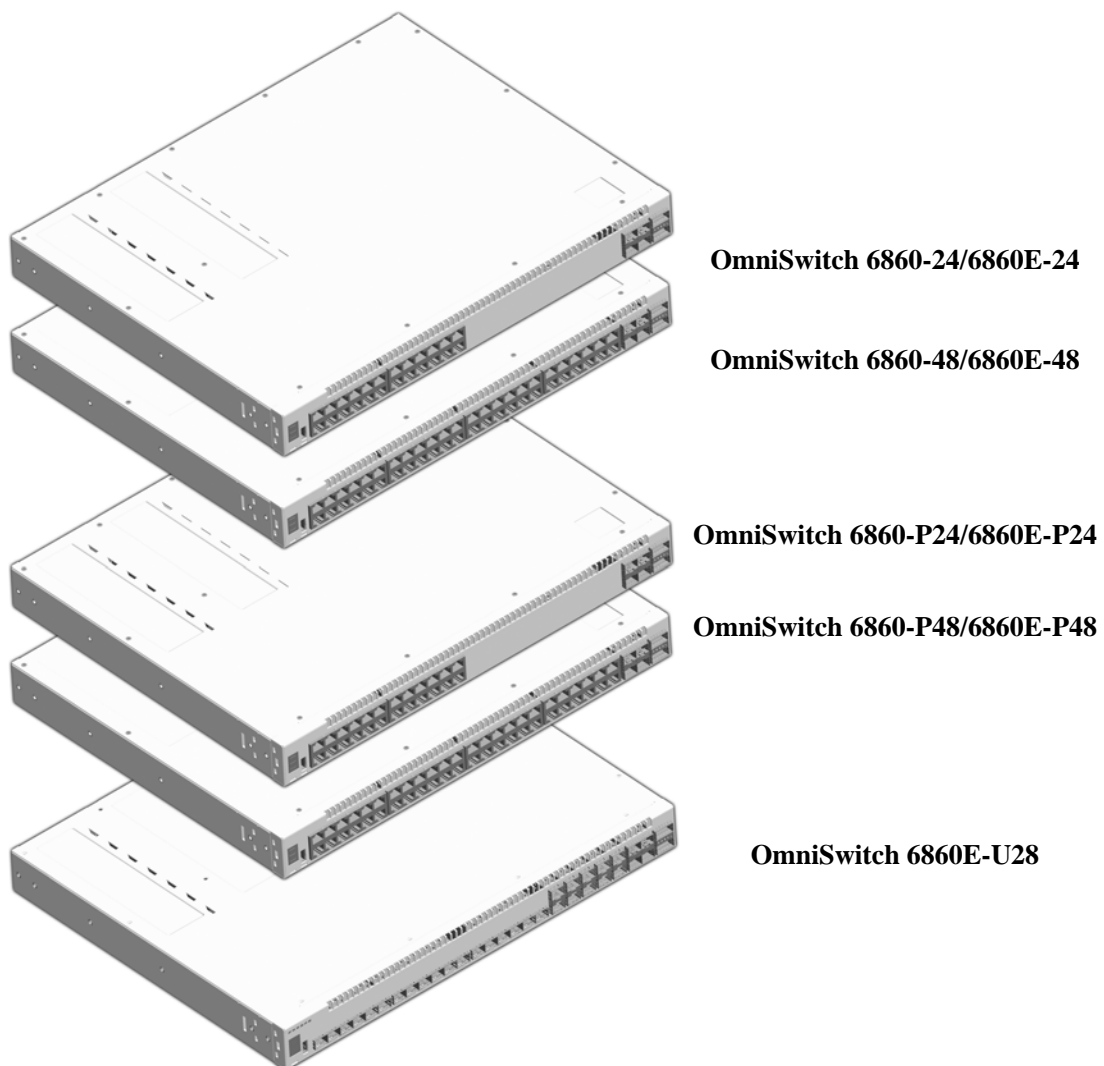

OmniSwitch 6860 Availability Features

The switch provides a broad variety of availability features. Availability features are hardware and software-based safeguards that help prevent the loss of data flow in the unlikely event of a subsystem failure. In addition, some availability features allow users to maintain or replace hardware components without powering off the switch or interrupting switch operations. Combined, these features provide added resiliency and help ensure that the switch is consistently available for day-to-day network operations.

Hardware-related availability features include:

- [Power Supply Redundancy](#)
- [Hot-Swapping](#)
- [Hardware Monitoring](#)

Power Supply Redundancy

For information on power supply redundancy, refer to [Chapter 3, “Chassis and Power Supplies.”](#)

Hot-Swapping

Hot-swapping refers to the action of adding, removing, or replacing certain hardware components without powering off your switch and disrupting other components in the chassis. This feature greatly facilitates hardware upgrades and maintenance and also allows you to easily replace components in the unlikely event of hardware failure. The following hardware components can be hot-swapped:

- Power supplies
- Transceivers
- Plug-in modules

Note. For information on adding and removing power supplies and plug-in modules, refer to [Chapter 3, “Chassis and Power Supplies.”](#)

Hardware Monitoring

Automatic Monitoring

Automatic monitoring refers to the switch's built-in sensors that automatically monitor operations. If an error is detected (e.g., over-threshold temperature), the switch immediately sends a trap to the user. The trap is displayed on the console in the form of a text error message.

LEDs

LEDs, which provide visual status information, are provided on the front and rear panels. LEDs are used to indicate conditions, such as hardware and software status, link integrity, data flow, etc. For detailed LED descriptions, refer to the corresponding hardware component section in the next chapter.

User-Driven Monitoring

User-driven hardware monitoring refers to CLI commands that are entered by the user in order to access the current status of hardware components. The user enters "show" commands that output information to the console. The show commands for all the features are described in detail in the *OmniSwitch CLI Reference Guide*.

2 Getting Started

Installing the Hardware

Note. For information on configuring a Virtual Chassis (VC), refer to the *OmniSwitch AOS Release 8 Switch Management Guide*.

Items Required

- Grounding wrist strap
- Phillips screwdriver
- Flat-blade screwdriver

Site Preparation

Environmental Requirements

OmniSwitch 6860 switches have the following environmental and airflow requirements:

- The installation site must maintain a temperature between 0° and 45° Celsius (32° and 113° Fahrenheit) and not exceed 95 percent maximum humidity (non-condensing) at any time.
- Be sure to allow adequate room for proper air ventilation at the front, back, and sides of the switch. Refer to [“Airflow Considerations” on page 2-4](#) for minimum clearance requirements. No clearance is necessary at the top or bottom of the chassis.

Electrical Requirements

Note. Alcatel-Lucent switches must be installed by a professional installer. It is the responsibility of the installer to ensure that proper grounding is available and that the installation meets applicable local and national electrical codes.

OmniSwitch 6860 switches have the following general electrical requirements:

- Each switch requires one grounded electrical outlet for each power supply installed in the chassis. OmniSwitch 6860 switches offer both AC and DC power supply support. Refer to the *OmniSwitch 6860 Hardware Users Guide* for more information.
- For switches using AC power connections, each supplied AC power cord is 2 meters (approx. 6.5 feet). Do not use extension cords.

Redundant AC Power. It is recommended that each AC outlet resides on a separate circuit. With redundant AC, if a single circuit fails, the switch's remaining power supplies (on separate circuits) can remain operational.

- For switches using DC power, refer to the [“DC Power Supply Connections”](#) on page 3-34 for more information.

Electrical Surge Warning

In order to help protect equipment against electrical surges please take note of the following recommendations and guidelines:

- 1** Earth grounding of all devices is fundamental to ensure long term reliability.
 - All electrical equipment must be installed by a qualified, licensed electrician.
 - Every power supply that is connected to building power should be earth grounded.
 - Earth grounding for the power cable, should be verified to be 0.01 ohm or less.
 - Each switch should be grounded to same earth ground as the power supply.
 - Each powered device, such as an AP or camera, should be connected to earth ground.
 - Each surge suppression device should be connected to earth ground.
- 2** Shielded cables (STP) offer some minimal level of additional protection over unshielded Ethernet cables (UTP) but the use of a surge protector is still recommended.
 - It is suggested to use STP Cat5e or better for 1Gbps Ethernet switches for any outdoor application or applications where Ethernet cables come in close proximity to alternating current conductors.
 - Always install cables according to manufacturer requirements.
- 3** For any connections where integrity of the cabling within a building ground is questionable (i.e outdoor connections), copper Ethernet ports must be connected with an appropriate surge protection device, inline, between the PSE and PD per the manufacturer's recommendations for connection and grounding.
- 4** Caution should be taken for any cable connected to any outdoor device, not only on the device grounding, but to ensure that any outdoor device cables that could carry surge currents, do not pass those surge currents to upstream Ethernet switches.
- 5** Caution - Category 5e, Category 6, and Category 6a cables can store large amounts of static electricity due to the dielectric properties of their construction materials in addition, this build up of electricity could lead to a Cable Discharge Event (CDE). A CDE can occur due to the differential in charges on the cable and the equipment it's being connected to. It is recommended that installers momentarily ground all copper Ethernet cables (especially in new cable runs) to a suitable and safe earth ground before connecting them to the port.

Note. Failure to follow the above recommendations could result in voiding the warranty of the affected ALE product.

Unpacking and Installing the Switch

To protect your switch components from damage, read all unpacking recommendations and instructions carefully before beginning.

Unpack your OmniSwitch 6860 chassis as close as possible to the location where it will be installed.

Items Included

Your OmniSwitch 6860 includes the following items:

- OmniSwitch chassis with power supplies, per order
- Transceivers, per order
- Blank cover panel
- Rack mount brackets
- Micro USB-to-USB cable
- Country-specific power cord(s)
- Rubber table-mounting feet
- Attachment screws
- Assorted instructional cards, anti-static bags and additional packaging

Weight Considerations

Depending on model type, an empty OmniSwitch 6860 chassis weighs between 4.45 kg (9.8 lbs) and 5.03 kg (11.1 lbs).

When fully populated with power supplies and mounting brackets, the OmniSwitch 6860 can weigh up to 6.49 kg (14.3 lbs). (Weights to not include transceivers or cabling.)

Airflow Considerations

To ensure proper airflow, be sure that your switch is placed in a well-ventilated area and provide minimum recommended clearance at the front, back and sides of the switch.

Never obstruct chassis air vents.

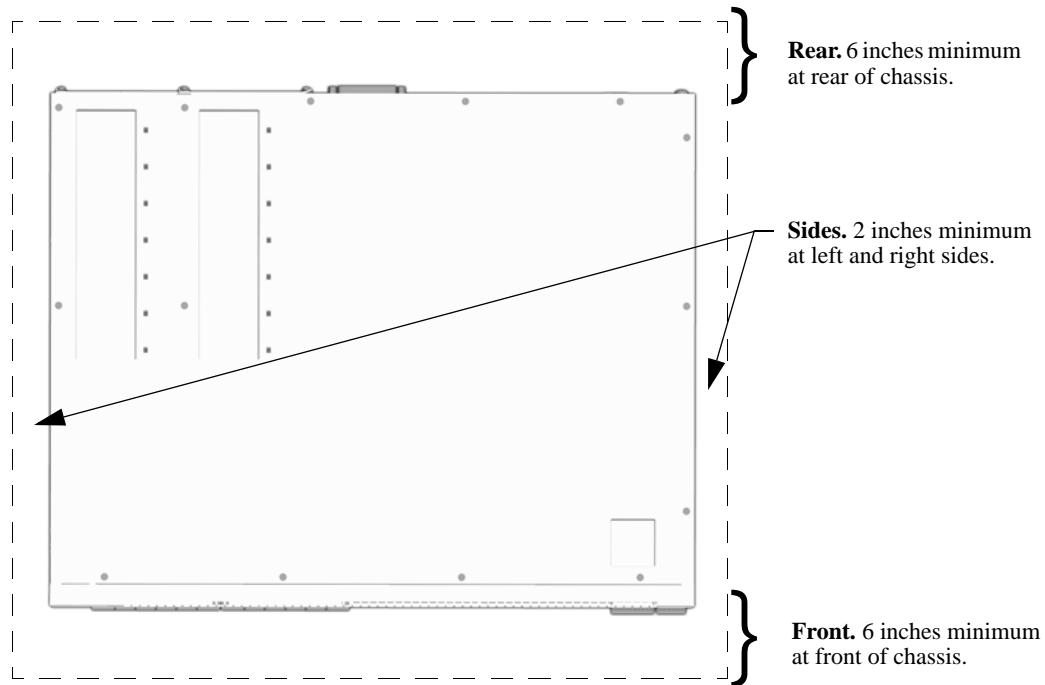

Chassis Top View

Note. Clearance is not required at the top and bottom of the chassis.

Mounting the Switch

For information on mounting OmniSwitch 6860 switches, refer to the [Chapter 3, “Chassis and Power Supplies.”](#)

Connections and Cabling

Once your switch is properly installed, you should connect all network and management cables required for your network applications. Connections may include:

- Micro USB-to-USB cable to the console connector
- Ethernet cable to the Ethernet Management Port (EMP) (Enhanced models only)
- Cables to NIs or transceivers

Note. For additional information on cabling for console, EMP, USB, Bluetooth and other connections, refer to the *OmniSwitch AOS Release 8 Switch Management Guide*.

Network Cable Installation Warning

Never install exposed network cables outdoors. Install network cables per manufacturer requirements.

Serial Connection to the Console Port

The console port provides a serial connection to the switch using a USB connector and is required when logging into the switch for the first time. By default, this connector provides a DCE console connection.

Serial Connection Default Settings

baud rate	9600
parity	none
data bits (word size)	8
stop bits	1

For information on modifying these settings, refer to the *OmniSwitch AOS Release 8 Switch Management Guide*.

Ethernet Management Port (EMP) Cable Requirements

Enhanced OS6860 models (OS6860E) provide an Ethernet Management Port (EMP) on the rear panel of the chassis for out-of-band management. There are specific cable type requirements (i.e., straight-through or crossover) based on the device to which the EMP is connecting. Refer to the information below:

EMP to a Switch	Straight-through
EMP to a Computer or Workstation	Crossover

For information on manually configuring Ethernet ports, refer to the *OmniSwitch AOS Release 8 Network Configuration Guide*.

Booting the Switch

Now that you have installed the switch components and connected network and management cables, you can boot the switch. To boot the switch, plug all power supply cords into easily-accessible, properly grounded power outlets. (Do not use extension cords.) The switch will power on and boot automatically.

Note. If you have more than one power supply installed, be sure to plug in each power supply in rapid succession, (i.e., within a few seconds of each other). This ensures that there will be adequate power for all components throughout the boot process.

Component LEDs

During the boot process, component LEDs will flash and change color, indicating different stages of the boot. Following a successful boot, chassis LEDs should display as follows:

OK1	Solid Green
PRI	Solid Green (for switches running in master role)
	Solid Amber (for switches running in slave role)
PS	Solid Green
BPS	Solid Green
GRN (Power Save)	Solid Green
OK2	Solid Green

If the LEDs do not display as indicated, make sure the boot process is complete. If the LEDs do not display as indicated following a complete boot sequence, contact Alcatel-Lucent Customer Support. For complete information on LED states, refer to [“Chassis Status LEDs” on page 3-19](#).

Once the switch has completely booted and you have accessed your computer’s terminal emulation software via the console port, you are ready to log in to the switch’s Command Line Interface (CLI) and configure basic information. Continue to [“Your First Login Session” on page 2-7](#).

Your First Login Session

In order to complete the setup process for the switch, you must complete the following steps during your first login session:

- Log in to the switch
- Set IP address information for the Ethernet Management Port (EMP) (Enhanced models only)
- Unlock session types
- Change the login password
- Set the date and time
- Set optional system information
- Save your changes

Important. You must be connected to the switch via the console port before initiating your first login session.

Logging In to the Switch

When you first log in to the switch, you will be prompted for a login name and password. Use the switch's default settings:

- Login: **admin**
- Password: **switch**

The default welcome banner, which includes information such as the current software version and system date, is displayed followed by the CLI command prompt:

```
Welcome to the Alcatel-Lucent OS6860E-P48 8.1.1, April 15, 2014.
```

```
Copyright (c) 1994-2014 Alcatel-Lucent. All Rights Reserved.
```

```
OmniSwitch(tm) is a trademark of Alcatel-Lucent, registered in the United States  
Patent and Trademark Office.
```

```
->
```

Note. A user account includes a login name, password, and user privileges. Privileges determine whether the user has read or write access to the switch and which commands the user is authorized to execute. For detailed information on setting up and modifying user accounts, refer to the *OmniSwitch AOS Release 8 Switch Management Guide*.

Setting IP Address Information for the EMP

If installing an Enhanced OS6860 model (OS6860E), the IP address may be set via the Ethernet Management Port (EMP). To connect to the switch through the EMP Ethernet connection, use the default address below or change the port's IP address.

Default EMP IP Address	192.168.1.1
Default EMP Mask	255.255.255.0

Note. You should be connected to the switch via the console port before attempting to change IP address information.

To change the default IP and mask, use the **ip interface** command. For example:

```
-> ip interface emp address 168.22.2.120 mask 255.255.255.0
```

Verify your settings using the **show ip interface** command. See the *OmniSwitch AOS Release 8 Switch Management Guide* for additional information regarding EMP port addressing.

Note. Although you have configured the EMP with valid IP address information, you will not be able to access the switch through this port (i.e. TELNET, FTP, HTTP, SSH or SNMP) until you have unlocked these remote session types. See [“Unlocking Session Types” on page 2-9](#) for more information.

Unlocking Session Types

Security is a key feature on OmniSwitch 6860 switches. As described on [page 2-7](#), when you access the switch for the first time, you must use a *direct console port connection*. All other session types (Telnet, FTP, WebView, and SNMP) are locked out until they are manually unlocked by the user.

The CLI command used to unlock session types is **aaa authentication**.

Note. When you unlock session types, you are granting switch access to non-local sessions (e.g., Telnet). As a result, users who know the correct user login and password will have remote access to the switch. For more information on switch security, refer to the *OmniSwitch AOS Release 8 Switch Management Guide*.

Unlocking All Session Types

To unlock all session types, enter the following command syntax at the CLI prompt:

```
-> aaa authentication default local
```

Unlocking Specified Session Types

You can also unlock session types on a one-by-one basis. For example, to unlock Telnet sessions only, enter the following command:

```
-> aaa authentication telnet local
```

To unlock WebView (HTTP) sessions only, enter the following command:

```
-> aaa authentication http local
```

You cannot specify more than one session type in a single command line. However, you can still unlock multiple session types by using the **aaa authentication** command in succession. For example:

```
-> aaa authentication http local
-> aaa authentication telnet local
-> aaa authentication ftp local
```

Refer to the *OmniSwitch CLI Reference Guide* for complete **aaa authentication** command syntax options.

Changing the Login Password

Change the login password for **admin** user sessions by following the steps below:

- 1 Be sure that you have logged into the switch as user type **admin** (see [“Logging In to the Switch” on page 2-7](#)).
- 2 Enter the keyword **password** and press **Enter**.
- 3 Enter your new password at the prompt.

Note. Be sure to remember or securely record all new passwords; overriding configured passwords on an OmniSwitch is restricted.

- 4 You will be prompted to re-enter the password. Enter the password a second time.

New password settings are automatically saved in real time to the local user database; the user is not required to enter an additional command in order to save the password information. Also note that new password information is retained following a reboot. All subsequent login sessions, including those through the console port, will require the new password to access the switch.

For detailed information on managing login information, including user names and passwords, refer to the *OmniSwitch AOS Release 8 Switch Management Guide*.

Setting the System Time Zone

The switch's default time zone is UTC. If you require a time zone that is specific to your region, or if you need to enable Daylight Savings Time (DST) on the switch, you can configure these settings via the **system timezone** and **system daylight-savings-time** commands.

For detailed information on configuring a time zone for the switch, refer to the *OmniSwitch AOS Release 8 Switch Management Guide*.

Setting the Date and Time

Set the current time for the switch by entering **system time**, followed by the current time in *hh:mm:ss*.

To set the current date for the switch, enter **system date**, followed by the current date in *mm/dd/yyyy*.

Setting Optional Parameters

Specifying an Administrative Contact

An administrative contact is the person or department in charge of the switch. If a contact is specified, users can easily find the appropriate network administrator if they have questions or comments about the switch.

To specify an administrative contact, use the **system contact** command.

Specifying a System Name

The system name is a simple, user-defined text description for the switch. To specify a system name, use the **system name** command.

Specifying the Switch's Location

It is recommended that you use a physical labeling system for locating and identifying your switch(es). Examples include placing a sticker or placard with a unique identifier (e.g., the switch's default IP address) on each chassis.

However, if no labeling system has been implemented or if you need to determine a switch's location from a remote site, entering a system location can be very useful.

To specify a system location, use the **system location** command.

Viewing Your Changes

To view your current changes, enter **show system** at the CLI prompt.

Saving Your Changes

Once you have configured this basic switch information, save your changes by entering **write memory** at the CLI command prompt.

3 Chassis and Power Supplies

This chapter includes detailed information on the OmniSwitch 6860 switch. Topics include:

- Chassis details and technical specifications:

Basic Models - Non-PoE

OS6860-24, [page 3-2](#).

OS6860-48, [page 3-4](#).

Basic Models - PoE

OS6860-P24, [page 3-6](#).

OS6860-P48, [page 3-8](#).

Enhanced Models - Non-PoE

OS6860E-24, [page 3-10](#).

OS6860E-48, [page 3-12](#).

OS6860E-U28, [page 3-14](#).

Enhanced Models - PoE

OS6860E-P24, [page 3-16](#).

OS6860E-P48, [page 3-18](#).

- Switch mounting information, [page 3-21](#).
- Power supplies and power supply redundancy, [page 3-30](#).
- Fan tray (non-PoE models only), [page 3-40](#).
- Temperature management, [page 3-41](#).
- Monitoring the chassis components via the Command Line Interface (CLI), [page 3-41](#)

OmniSwitch 6860 Chassis Details

Basic Models - Non-PoE

OS6860-24 Front Panel

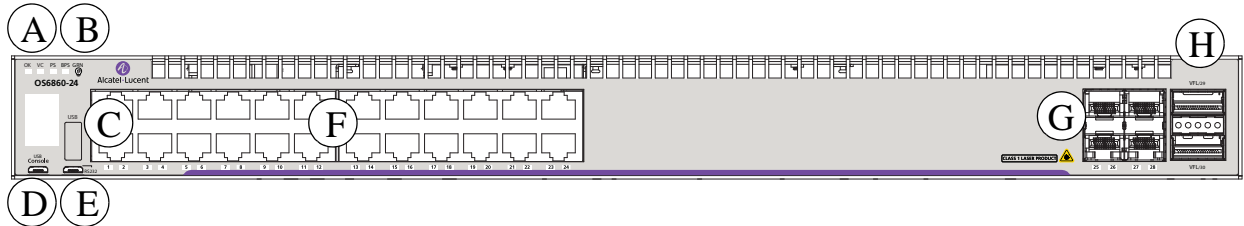

Item	Description
A	Virtual Chassis ID LED
B	Status LEDs
C	USB port
D	Console port
E	RS-232 port
F	(24) 10/100/1000 Base-T ports
G	(4) fixed SFP+ (1G/10G) ports
H	(2) 20G Virtual Chassis link ports

CLASS 1 M LASER CAUTION. CAUTION - CLASS 1 M LASER RADIATION WHEN OPEN. DO NOT VIEW DIRECTLY WITH OPTICAL INSTRUMENTS

OS6860-24 Rear Panel

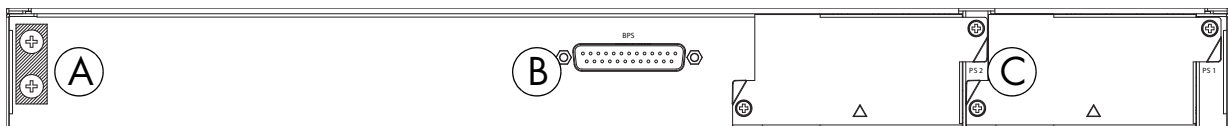

Item	Description
A	Chassis Grounding Lug
B	OmniSwitch Backup Power Supply (OS-BPS) (No longer supported.)
C	Power Supply/Fan Tray Bays

OS6860-24 Chassis Specifications

Chassis Height	4.4 cm (1.73 in)
Chassis Width	44 cm (17.33 in)
Chassis Depth	35 cm (13.78 in)
OS6860-24 Chassis Weight	4.45 kg (9.8 lb)
OS6860-24 Chassis Weight (fully populated) ¹	5.17 kg (11.4 lb)
OS6860-24 Power Consumption (full system power)	46 W
Altitude	13,000 ft
Operating Temperature (Tmra)	0°C to 45°C (32°F to 113°F)
Storage Temperature	-40°C to 85°C (-40°F to 185°F)
Operating Humidity	5% to 95% non-condensing
Storage Humidity	5% to 95% non-condensing

¹ Fully populated weights include installed power supplies. These figures do not include transceivers.

***Note On Chassis Versus Ambient Temperatures.** Chassis temperature refers to the sensor reading of the internal switch temperature (threshold or danger). Ambient temperature refers to the approximate room temperature. The ambient temperature will typically be lower than the chassis temperature.

OS6860-48 Front Panel

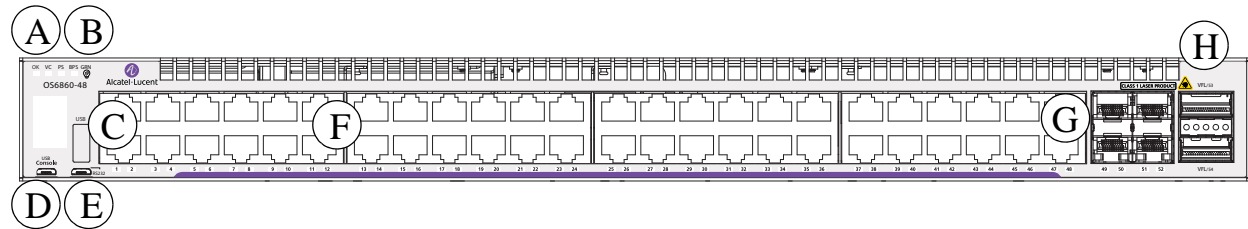

Item	Description
A	Virtual Chassis ID LED
B	Status LEDs
C	USB port
D	Console port
E	RS-232 port
F	(48) 10/100/1000 Base-T ports
G	(4) fixed SFP+ (1G/10G) ports
H	(2) 20G Virtual Chassis link ports

CLASS 1 M LASER CAUTION. CAUTION - CLASS 1 M LASER RADIATION WHEN OPEN. DO NOT VIEW DIRECTLY WITH OPTICAL INSTRUMENTS

OS6860-48 Rear Panel

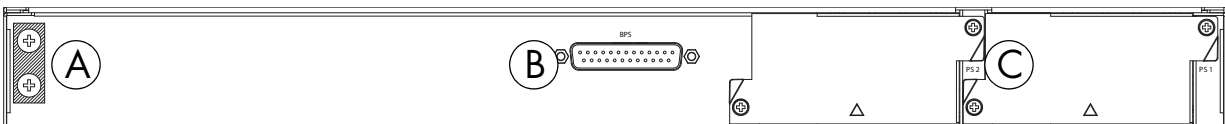

Item	Description
A	Chassis Grounding Lug
B	OmniSwitch Backup Power Supply (OS-BPS) (No longer supported.)
C	Power Supply/Fan Tray Bays

OS6860-48 Chassis Specifications

Chassis Height	4.4 cm (1.73 in)
Chassis Width	44 cm (17.33 in)
Chassis Depth	35 cm (13.78 in)
OS6860-48 Chassis Weight	4.67 kg (10.3 lb)
OS6860-48 Chassis Weight (fully populated) ¹	5.40 kg (11.9 lb)
OS6860-48 Power Consumption (full system power)	57 W
Altitude	13,000 ft
Operating Temperature (Tmra)	0°C to 45°C (32°F to 113°F)
Storage Temperature	-40°C to 85°C (-40°F to 185°F)
Operating Humidity	5% to 95% non-condensing
Storage Humidity	5% to 95% non-condensing

¹ Fully populated weights include installed power supplies. These figures do not include transceivers.

***Note On Chassis Versus Ambient Temperatures.** Chassis temperature refers to the sensor reading of the internal switch temperature (threshold or danger). Ambient temperature refers to the approximate room temperature. The ambient temperature will typically be lower than the chassis temperature.

Basic Models - PoE

OS6860-P24 Front Panel

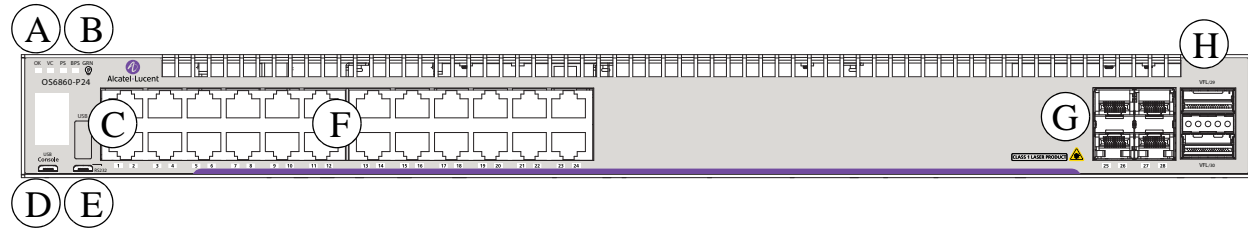

Item	Description
A	Virtual Chassis ID LED
B	Status LEDs
C	USB port
D	Console port
E	RS-232 port
F	(24) 10/100/1000 Base-T PoE ports
G	(4) fixed SFP+ (1G/10G) ports
H	(2) 20G Virtual Chassis link ports

CLASS 1 M LASER CAUTION. CAUTION - CLASS 1 M LASER RADIATION WHEN OPEN. DO NOT VIEW DIRECTLY WITH OPTICAL INSTRUMENTS

OS6860-P24 Rear Panel

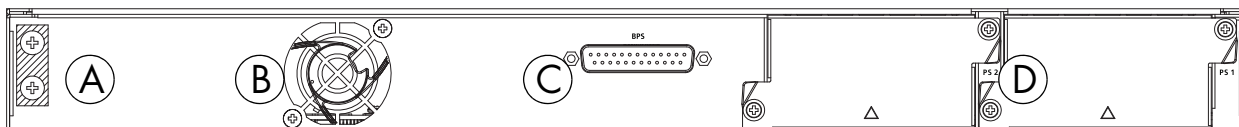

Item	Description
A	Chassis Grounding Lug
B	Fan Vent
C	OmniSwitch Backup Power Supply (OS-BPS) (No longer supported.)
D	PoE Power Supply Bays

OS6860-P24 Chassis Specifications

Chassis Height	4.4 cm (1.73 in)
Chassis Width	44 cm (17.33 in)
Chassis Depth	35 cm (13.78 in)
OS6860-P24 Chassis Weight	4.58 kg (10.1 lb)
OS6860-P24 Chassis Weight (fully populated) ¹	6.03 kg (13.3 lb)
OS6860-P24 Power Consumption (full system power) ²	75 W
Altitude	13,000 ft
Operating Temperature (Tmra)	0°C to 45°C (32°F to 113°F)
Storage Temperature	-40°C to 85°C (-40°F to 185°F)
Operating Humidity	5% to 95% non-condensing
Storage Humidity	5% to 95% non-condensing

¹ Fully populated weights include installed power supplies. These figures do not include transceivers.

² Does not include attached PoE devices.

***Note On Chassis Versus Ambient Temperatures.** Chassis temperature refers to the sensor reading of the internal switch temperature (threshold or danger). Ambient temperature refers to the approximate room temperature. The ambient temperature will typically be lower than the chassis temperature.

OS6860-P48 Front Panel

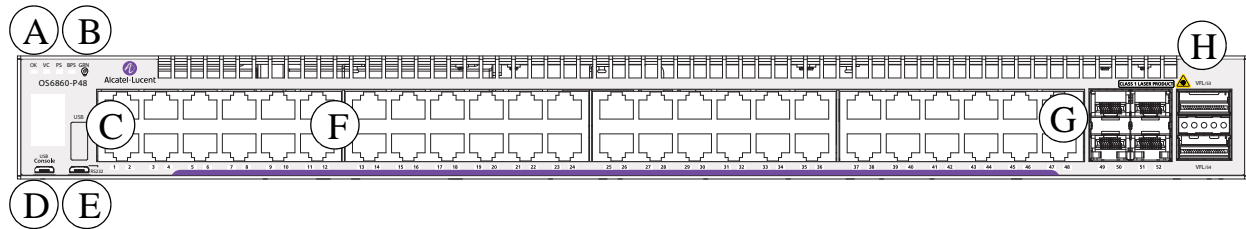

Item	Description
A	Virtual Chassis ID LED
B	Status LEDs
C	USB port
D	Console port
E	RS-232 port
F	(48) 10/100/1000 Base-T PoE ports
G	(4) fixed SFP+ (1G/10G) ports
H	(2) 20G Virtual Chassis link ports

CLASS 1 M LASER CAUTION. CAUTION - CLASS 1 M LASER RADIATION WHEN OPEN. DO NOT VIEW DIRECTLY WITH OPTICAL INSTRUMENTS

OS6860-P48 Rear Panel

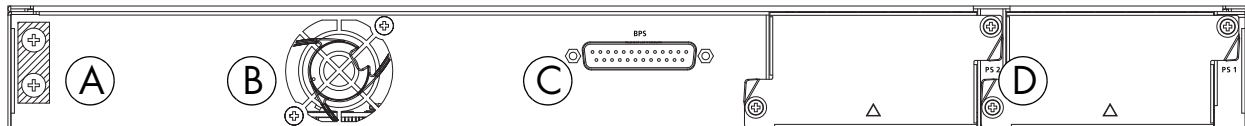

Item	Description
A	Chassis Grounding Lug
B	Fan Vent
C	OmniSwitch Backup Power Supply (OS-BPS) (No longer supported.)
D	PoE Power Supply Bays

OS6860-P48 Chassis Specifications

Chassis Height	4.4 cm (1.73 in)
Chassis Width	44 cm (17.33 in)
Chassis Depth	35 cm (13.78 in)
OS6860-P48 Chassis Weight	4.90 kg (10.8 lb)
OS6860-P48 Chassis Weight (fully populated) ¹	6.35 kg (14.0 lb)
OS6860-P48 Power Consumption (full system power) ²	89 W
Altitude	13,000 ft
Operating Temperature (Tmra)	0°C to 45°C (32°F to 113°F)
Storage Temperature	-40°C to 85°C (-40°F to 185°F)
Operating Humidity	5% to 95% non-condensing
Storage Humidity	5% to 95% non-condensing

¹ Fully populated weights include installed power supplies. These figures do not include transceivers.

² Does not include attached PoE devices.

***Note On Chassis Versus Ambient Temperatures.** Chassis temperature refers to the sensor reading of the internal switch temperature (threshold or danger). Ambient temperature refers to the approximate room temperature. The ambient temperature will typically be lower than the chassis temperature.

Enhanced Models - Non-PoE

OS6860E-24 Front Panel

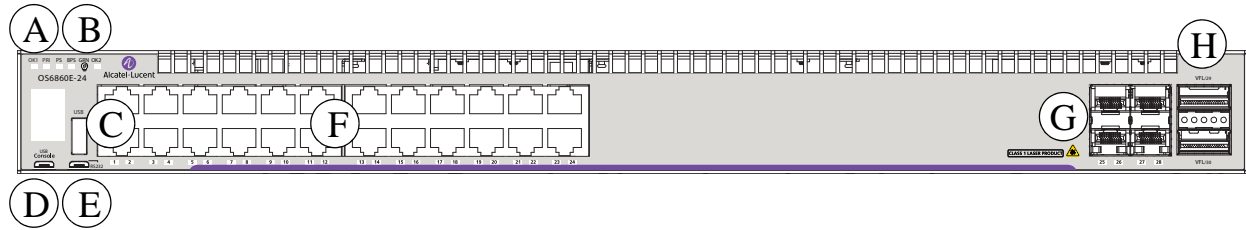

Item	Description
A	Virtual Chassis ID LED
B	Status LEDs
C	USB port
D	Console port
E	RS-232 port
F	(24) 10/100/1000 Base-T ports
G	(4) fixed SFP+ (1G/10G) ports
H	(2) 20G Virtual Chassis link ports

CLASS 1 M LASER CAUTION. CAUTION - CLASS 1 M LASER RADIATION WHEN OPEN. DO NOT VIEW DIRECTLY WITH OPTICAL INSTRUMENTS

OS6860E-24 Rear Panel

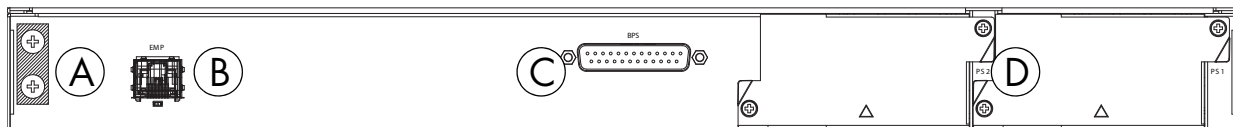

Item	Description
A	Chassis Grounding Lug
B	Ethernet Management Port (EMP) for Out-of-Band Management
C	OmniSwitch Backup Power Supply (OS-BPS) (No longer supported.)
D	Power Supply/Fan Tray Bays

OS6860E-24 Chassis Specifications

Chassis Height	4.4 cm (1.73 in)
Chassis Width	44 cm (17.33 in)
Chassis Depth	35 cm (13.78 in)
OS6860E-24 Chassis Weight	4.58 kg (10.1 lb)
OS6860E-24 Chassis Weight (fully populated) ¹	5.26 kg (11.6 lb)
OS6860E-24 Power Consumption (full system power)	48 W
Altitude	13,000 ft
Operating Temperature (Tmra)	0°C to 45°C (32°F to 113°F)
Storage Temperature	-40°C to 85°C (-40°F to 185°F)
Operating Humidity	5% to 95% non-condensing
Storage Humidity	5% to 95% non-condensing

¹ Fully populated weights include installed power supplies. These figures do not include transceivers.

***Note On Chassis Versus Ambient Temperatures.** Chassis temperature refers to the sensor reading of the internal switch temperature (threshold or danger). Ambient temperature refers to the approximate room temperature. The ambient temperature will typically be lower than the chassis temperature.

OS6860E-48 Front Panel

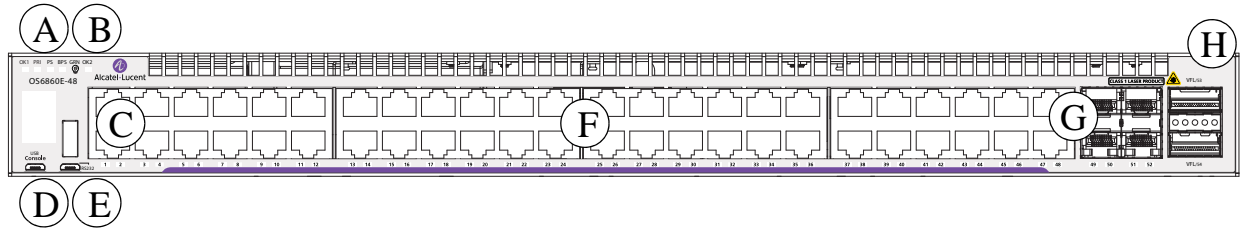

Item	Description
A	Virtual Chassis ID LED
B	Status LEDs
C	USB port
D	Console port
E	RS-232 port
F	(48) 10/100/1000 Base-T ports
G	(4) fixed SFP+ (1G/10G) ports
H	(2) 20G Virtual Chassis link ports

CLASS 1 M LASER CAUTION. CAUTION - CLASS 1 M LASER RADIATION WHEN OPEN. DO NOT VIEW DIRECTLY WITH OPTICAL INSTRUMENTS

OS6860E-48 Rear Panel

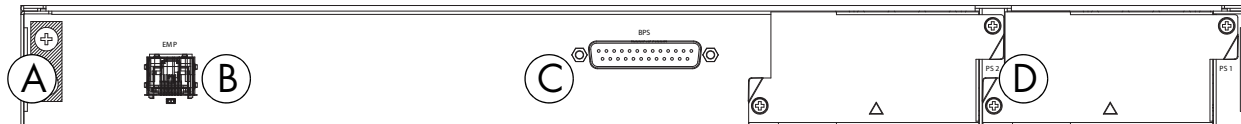

Item	Description
A	Chassis Grounding Lug
B	Ethernet Management Port (EMP) for Out-of-Band Management
C	OmniSwitch Backup Power Supply (OS-BPS) (No longer supported.)
D	Power Supply/Fan Tray Bays

OS6860E-48 Chassis Specifications

Chassis Height	4.4 cm (1.73 in)
Chassis Width	44 cm (17.33 in)
Chassis Depth	35 cm (13.78 in)
OS6860E-48 Chassis Weight	4.81 kg (10.6 lb)
OS6860E-48 Chassis Weight (fully populated) ¹	5.49 kg (12.1 lb)
OS6860E-48 Power Consumption (full system power)	60 W
Altitude	13,000 ft
Operating Temperature (Tmra)	0°C to 45°C (32°F to 113°F)
Storage Temperature	-40°C to 85°C (-40°F to 185°F)
Operating Humidity	5% to 95% non-condensing
Storage Humidity	5% to 95% non-condensing

¹ Fully populated weights include installed power supplies. These figures do not include transceivers.

***Note On Chassis Versus Ambient Temperatures.** Chassis temperature refers to the sensor reading of the internal switch temperature (threshold or danger). Ambient temperature refers to the approximate room temperature. The ambient temperature will typically be lower than the chassis temperature.

OS6860E-U28 Front Panel

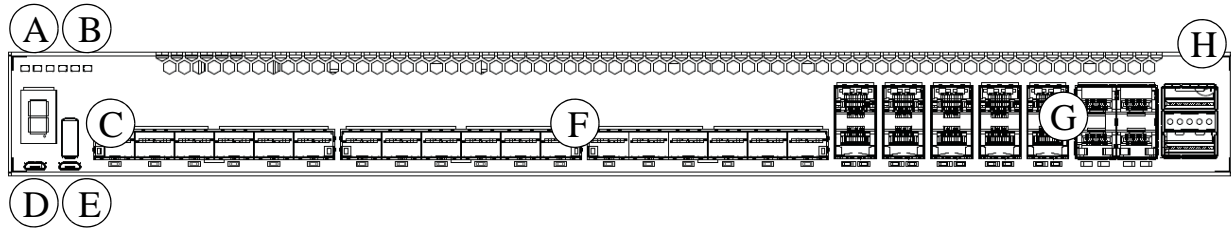

Item	Description
A	Virtual Chassis ID LED
B	Status LEDs
C	USB port
D	Console port
E	RS-232 port
F	(28) 1000Base-X/100Base-FX ports
G	(4) fixed SFP+ (1G/10G) ports
H	(2) 20G Virtual Chassis link ports

CLASS 1 M LASER CAUTION. CAUTION - CLASS 1 M LASER RADIATION WHEN OPEN. DO NOT VIEW DIRECTLY WITH OPTICAL INSTRUMENTS

OS6860E-U28 Rear Panel

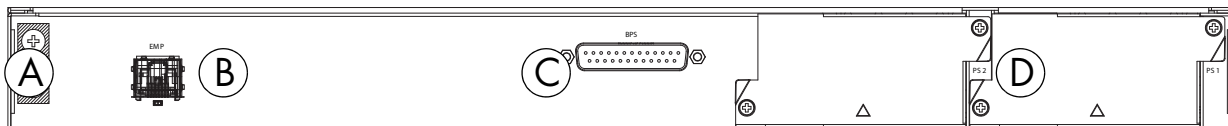

Item	Description
A	Chassis Grounding Lug
B	Ethernet Management Port (EMP) for Out-of-Band Management
C	OmniSwitch Backup Power Supply (OS-BPS) (No longer supported.)
D	Power Supply/Fan Tray Bays

OS6860E-U28 Chassis Specifications

Chassis Height	4.4 cm (1.73 in)
Chassis Width	44 cm (17.33 in)
Chassis Depth	35 cm (13.78 in)
OS6860E-U28 Chassis Weight	4.58 kg (10.1 lb)
OS6860E-U28 Chassis Weight (fully populated) ¹	5.26 kg (11.6 lb)
OS6860E-U28 Power Consumption (full system power)	73 W
Altitude	13,000 ft
Operating Temperature (Tmra)	0°C to 45°C (32°F to 113°F)
Storage Temperature	-40°C to 85°C (-40°F to 185°F)
Operating Humidity	5% to 95% non-condensing
Storage Humidity	5% to 95% non-condensing

¹ Fully populated weights include installed power supplies. These figures do not include transceivers.

***Note On Chassis Versus Ambient Temperatures.** Chassis temperature refers to the sensor reading of the internal switch temperature (threshold or danger). Ambient temperature refers to the approximate room temperature. The ambient temperature will typically be lower than the chassis temperature.

Enhanced Models - PoE

OS6860E-P24 Front Panel

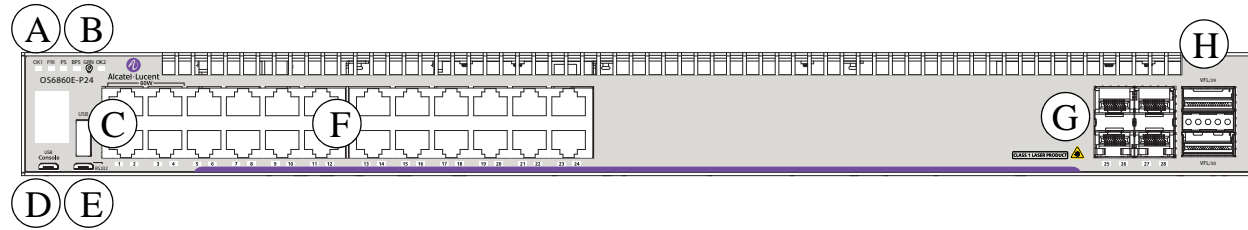

Item	Description
A	Virtual Chassis ID LED
B	Status LEDs
C	USB port
D	Console port
E	RS-232 port
F	(24) 10/100/1000 Base-T PoE ports
G	(4) fixed SFP+ (1G/10G) ports
H	(2) 20G Virtual Chassis link ports

CLASS 1 M LASER CAUTION. CAUTION - CLASS 1 M LASER RADIATION WHEN OPEN. DO NOT VIEW DIRECTLY WITH OPTICAL INSTRUMENTS

OS6860E-P24 Rear Panel

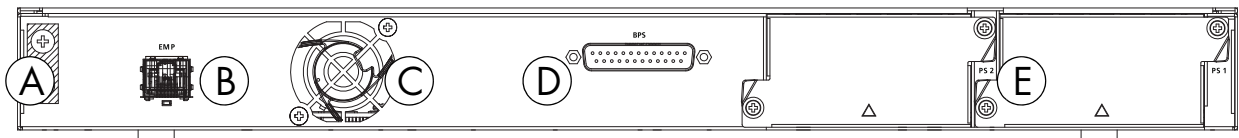

Item	Description
A	Chassis Grounding Lug
B	Ethernet Management Port (EMP) for Out-of-Band Management
C	Fan Vent
D	OmniSwitch Backup Power Supply (OS-BPS) (No longer supported.)
E	Power Supply Bays

OS6860E-P24 Chassis Specifications

Chassis Height	4.4 cm (1.73 in)
Chassis Width	44 cm (17.33 in)
Chassis Depth	35 cm (13.78 in)
OS6860E-P24 Chassis Weight	4.81 kg (10.6 lb)
OS6860E-P24 Chassis Weight (fully populated) ¹	6.26 kg (13.8 lb)
OS6860E-P24 Power Consumption (full system power) ²	76 W
Altitude	13,000 ft
Operating Temperature (Tmra)	0°C to 45°C (32°F to 113°F)
Storage Temperature	-40°C to 85°C (-40°F to 185°F)
Operating Humidity	5% to 95% non-condensing
Storage Humidity	5% to 95% non-condensing

¹ Fully populated weights include installed power supplies. These figures do not include transceivers.

² Does not include attached PoE devices.

***Note On Chassis Versus Ambient Temperatures.** Chassis temperature refers to the sensor reading of the internal switch temperature (threshold or danger). Ambient temperature refers to the approximate room temperature. The ambient temperature will typically be lower than the chassis temperature.

OS6860E-P48 Front Panel

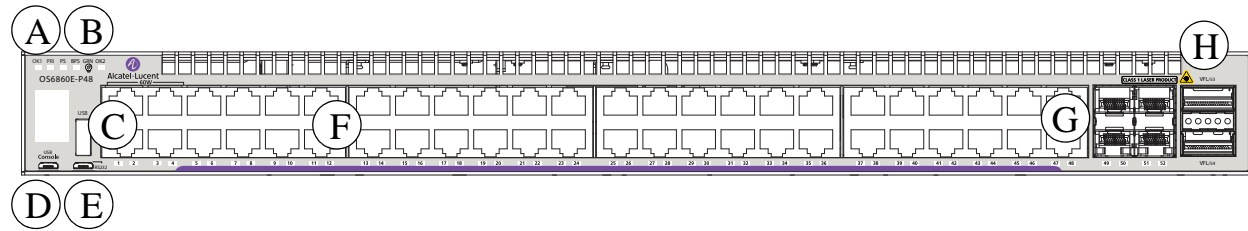

Item	Description
A	Virtual Chassis ID LED
B	Status LEDs
C	USB port
D	Console port
E	RS-232 port
F	(48) 10/100/1000 Base-T PoE ports
G	(4) fixed SFP+ (1G/10G) ports
H	(2) 20G Virtual Chassis link ports

CLASS 1 M LASER CAUTION. CAUTION - CLASS 1 M LASER RADIATION WHEN OPEN. DO NOT VIEW DIRECTLY WITH OPTICAL INSTRUMENTS

OS6860E-P48 Rear Panel

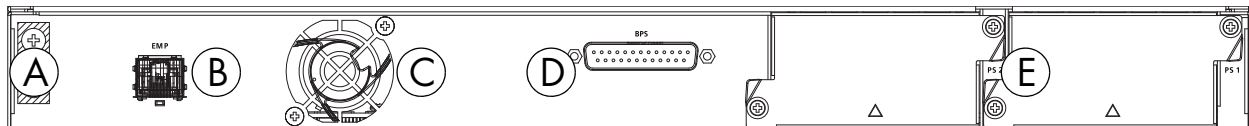

Item	Description
A	Chassis Grounding Lug
B	Ethernet Management Port (EMP) for Out-of-Band Management
C	Fan Vent
D	OmniSwitch Backup Power Supply (OS-BPS) (No longer supported.)
E	Power Supply Bays

OS6860E-P48 Chassis Specifications

Chassis Height	4.4 cm (1.73 in)
Chassis Width	44 cm (17.33 in)
Chassis Depth	35 cm (13.78 in)
OS6860E-P48 Chassis Weight	5.03 kg (11.1 lb)
OS6860E-P48 Chassis Weight (fully populated) ¹	6.49 kg (14.3 lb)
OS6860E-P48 Power Consumption (full system power) ²	93 W
Altitude	13,000 ft
Operating Temperature (Tmra)	0°C to 45°C (32°F to 113°F)
Storage Temperature	-40°C to 85°C (-40°F to 185°F)
Operating Humidity	5% to 95% non-condensing
Storage Humidity	5% to 95% non-condensing

¹ Fully populated weights include installed power supplies. These figures do not include transceivers.

¹ Does not include attached PoE devices.

***Note On Chassis Versus Ambient Temperatures.** Chassis temperature refers to the sensor reading of the internal switch temperature (threshold or danger). Ambient temperature refers to the approximate room temperature. The ambient temperature will typically be lower than the chassis temperature.

Chassis Status LEDs

The chassis provides a series of status LEDs located on the front panel. These LEDs offer basic status information for hardware operation and port link and activity status.

LED	State	Description
OK1	Solid Green	System Diagnostics and AOS bootup OK
	Blinking Green	System Diagnostics and AOS in progress (i.e., performing diagnostics or booting)
	Solid Amber	System Diagnostics and/or AOS bootup failed
VC	Solid Green	This unit is the master unit
	Solid Amber	This unit is a slave unit
	Off	This unit is in shutdown mode or is not part of a VC.

LED	State	Description
PS	Solid Green	Two power supplies are installed in the chassis and both supplies are functioning normally.
	Solid Green	One power supplies is installed in the chassis and functioning normally (with the second power supply bay empty or occupied by a fan tray).
	Solid Amber	Two power supplies are installed in the chassis and one or both supplies has experienced a failure.
	Solid Amber	One power supply is installed in the chassis and has experienced a failure (with the second power supply bay empty or occupied by a fan tray).
	Off	No power supply is present.
BPS	Solid Green	Backup power supply is operating normally
	Solid Amber	Backup power supply is operating, but a fault is present
	Off	No backup power supply is present
GRN	Solid Green	Power save features are active
	Off	Power save features are off
OK2 (Enhanced models only)	Solid Green	External CPU Diagnostics and AOS bootup OK
	Blinking Green	External CPU Diagnostics in progress
	Solid Amber	External CPU Diagnostic and/or AOS bootup failed
Port LEDs	Solid Green	Valid port link (non-PoE)
	Blinking Green	Valid port link with activity (non-PoE)
	Solid Amber	Valid port link (PoE)
	Blinking Amber	Valid port link with activity (PoE)

Mounting the Switch

General Mounting Recommendations

Elevated Operating Ambient Temperature. If installed in a closed or multi-rack assembly, the operating ambient temperature of the rack environment may be greater than the room's ambient temperature. Therefore, consideration should be given to the maximum rated ambient temperature (T_{mra}) listed in the [“OmniSwitch 6860 Chassis Details”](#) section.

Reduced Air Flow. Installation of the equipment in a rack should be such that the amount of air flow required for safe operation of the equipment is not compromised. Refer to [“Airflow Recommendations” on page 3-22](#) for more information.

Mechanical Loading. Mounting of the equipment in the rack should be such that a hazardous condition is not achieved due to uneven loading.

Circuit Overloading. Consideration should be given to the connection of the equipment to the supply circuit and the effect that overloading of circuits could have on overcurrent protection and supply wiring.

Reliable Earthing. Reliable earthing of rack-mounted equipment should be maintained. Particular attention should be given to supply connections other than direct connections to the branch (e.g., use of power strips).

Airflow Recommendations

To ensure proper airflow, be sure that your switch is placed in a well-ventilated area and provide minimum recommended clearance at the front, back and sides of the switch, as shown below. Restricted airflow can cause your switch to overheat, which can lead to switch failure. Refer to the following important guidelines regarding airflow:

Follow the guidelines below regarding the minimum clearance requirements when mounting the chassis.

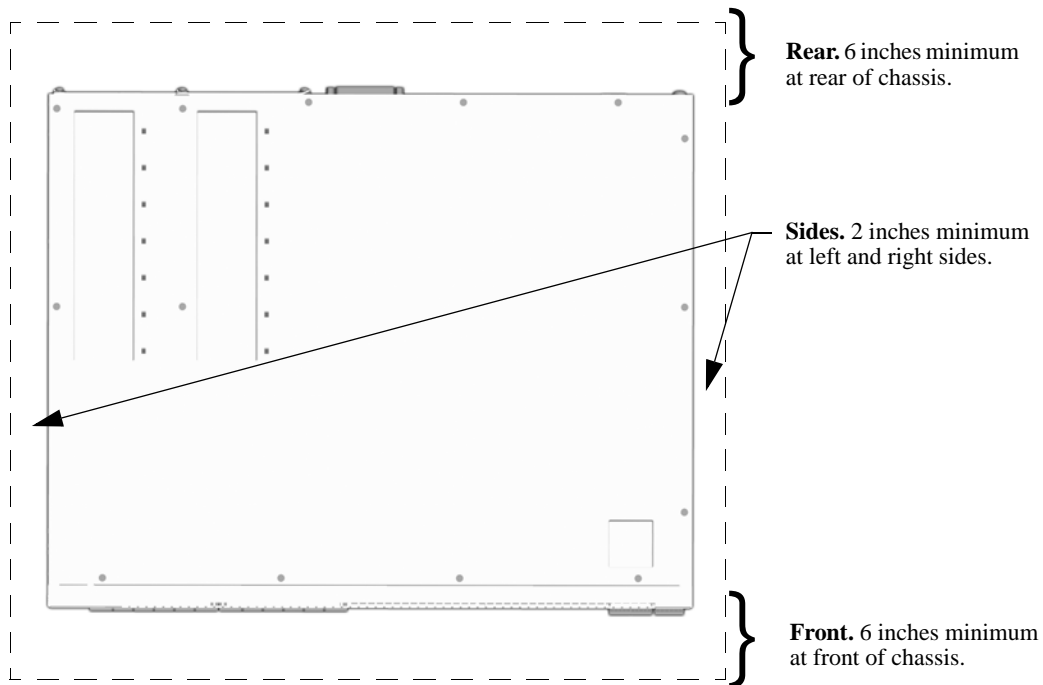

Chassis Top View

Note. Clearance is not required at the top and bottom of the chassis.

Blank Cover Panels

Blank cover panels are provided with your switch and are used to cover empty slots. These cover panels play an important role in chassis airflow and temperature management. If your switch is not fully populated and blank cover panels are not installed over empty slot locations, airflow is adversely affected.

When blank cover panels are missing, air does not take the direct route from the air intake vents. As a result, normal airflow is disrupted and an extra task is placed on the power supply fans to cool the chassis.

Cover panels also provide protection for module processor boards and other sensitive internal switch components by closing off a chassis that is not fully populated.

Note. Because they regulate airflow and help protect internal chassis components, blank cover panels should be installed over empty module slots and power supply bays at all times.

Installing Blank Cover Panels

- 1 When installing blank cover panels over power supply slots, orient the cover panels with the arrows pointing up.

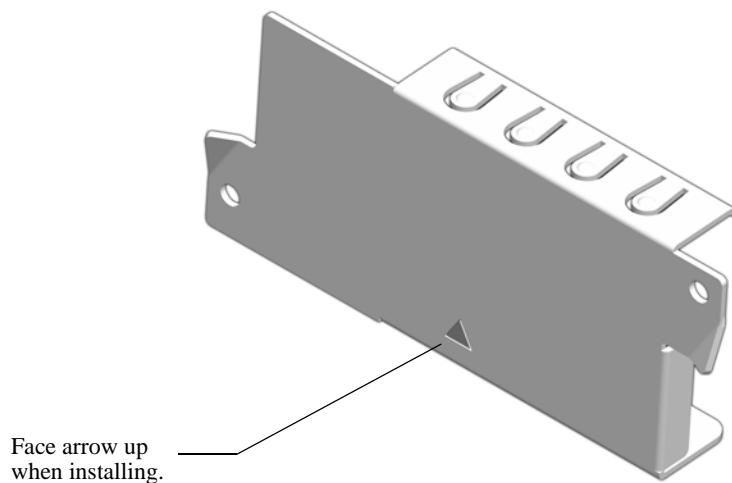

- 2 Insert the blank cover panel in the empty chassis slot and secure using attachment screws (provided).

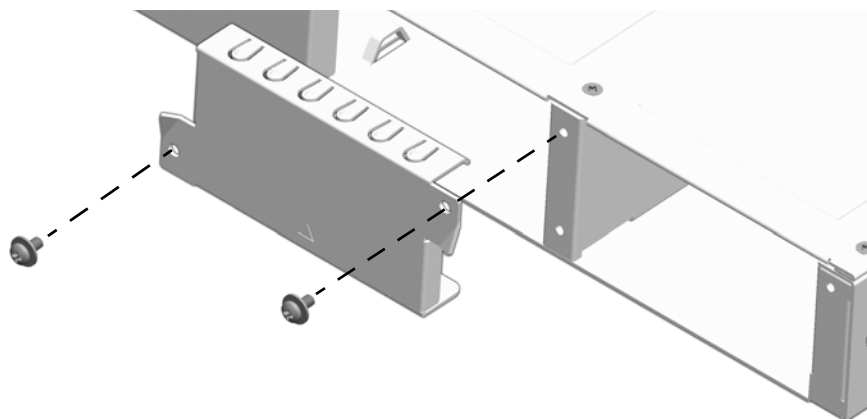

Rack-Mounting

Refer to the following important guidelines before installing the chassis in a rack:

- Two people are required to rack mount the switch: One person to lift the chassis into position and one person to secure the chassis to the rack using the rack mount screws.
- The chassis has rack-mount flanges that support standard 19-inch rack mount installations.
- Alcatel-Lucent Enterprise does not provide rack-mount screws. Use the screws supplied by the rack vendor.
- To prevent a rack from becoming top heavy, it is recommended that you install the switch at the bottom of the rack whenever possible.

Note. If you are installing the switch in a relay rack, be sure to install and secure the rack per rack manufacturer's specifications.

Installing Rack Mount Flanges

- 1 To install rack mount flanges, start by making sure the spring clip is in the out (disengaged) position.
- 2 Insert the tab into the chassis slot as shown.

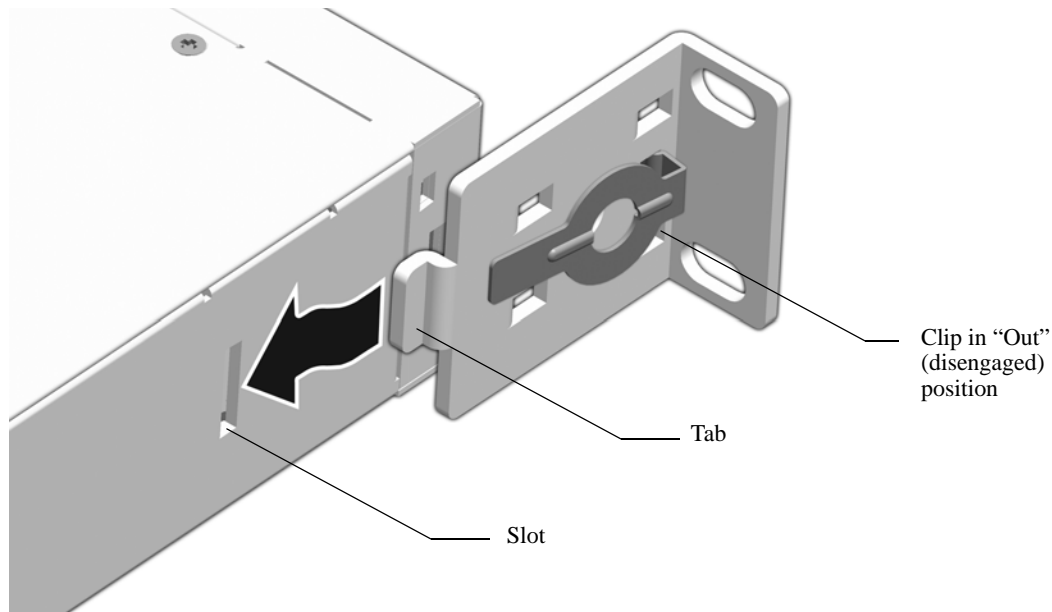

- 3 Press the flange and spring clip until the flange clicks into place and the clip is in the in (engaged) position.

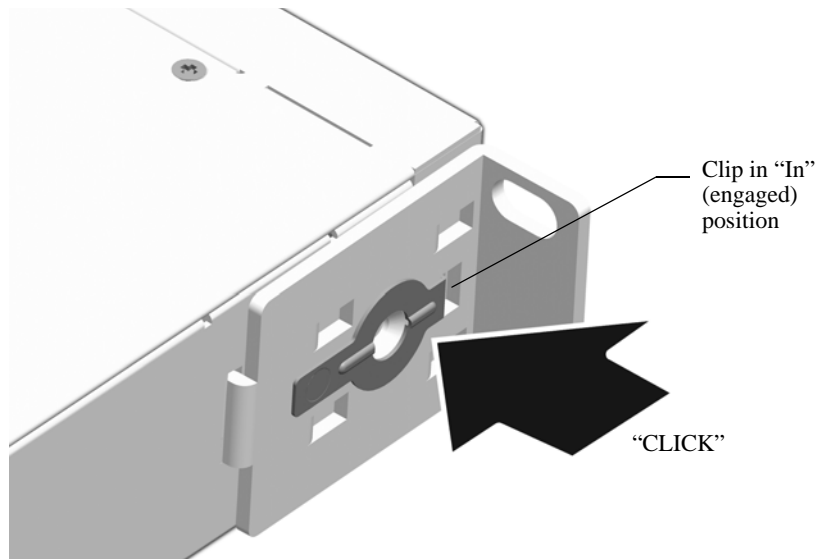

- 4 Secure the flange to the chassis using the attachment screw (provided).

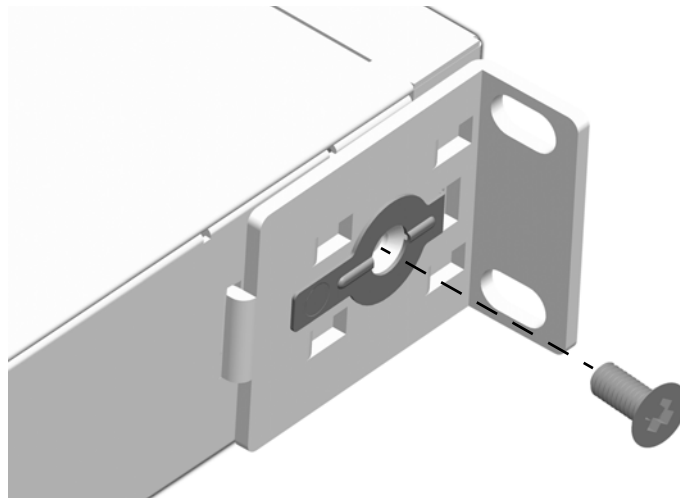

- 5 Repeat steps 1 through 4 for the flange on the opposite side of the chassis.

Installing the Chassis In the Rack

- 1** Mark the holes on the rack where the chassis is to be installed.
- 2** One person should lift and position the chassis until the rack-mount flanges are flush with the rack post.
- 3** Align the holes in the flanges with the rack holes marked in step 1.
- 4** Once the holes are aligned, the second person should insert a screw through the *bottom hole on each flange*. Tighten both screws until they are secure.

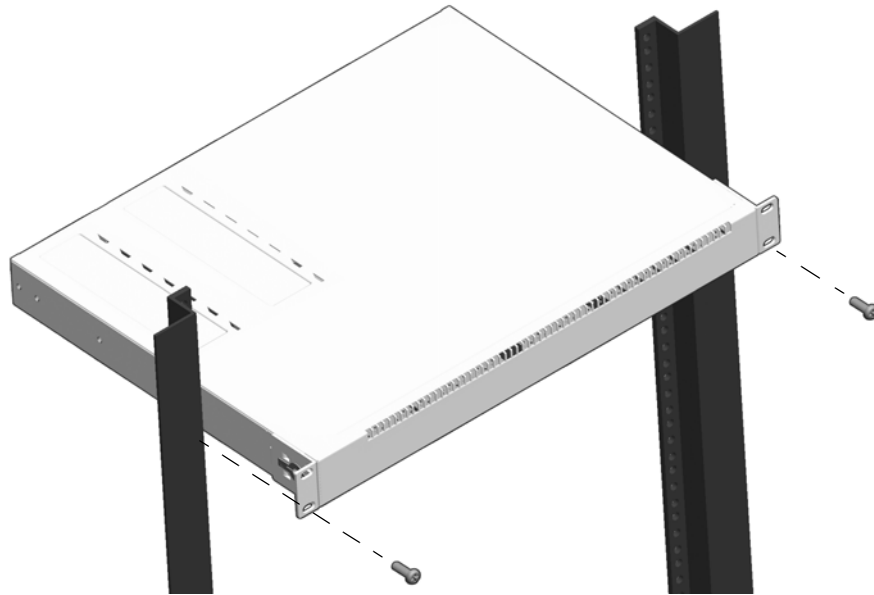

- 5** Install the remaining screws in the top hole of each flange. Be sure that all screws are securely tightened.

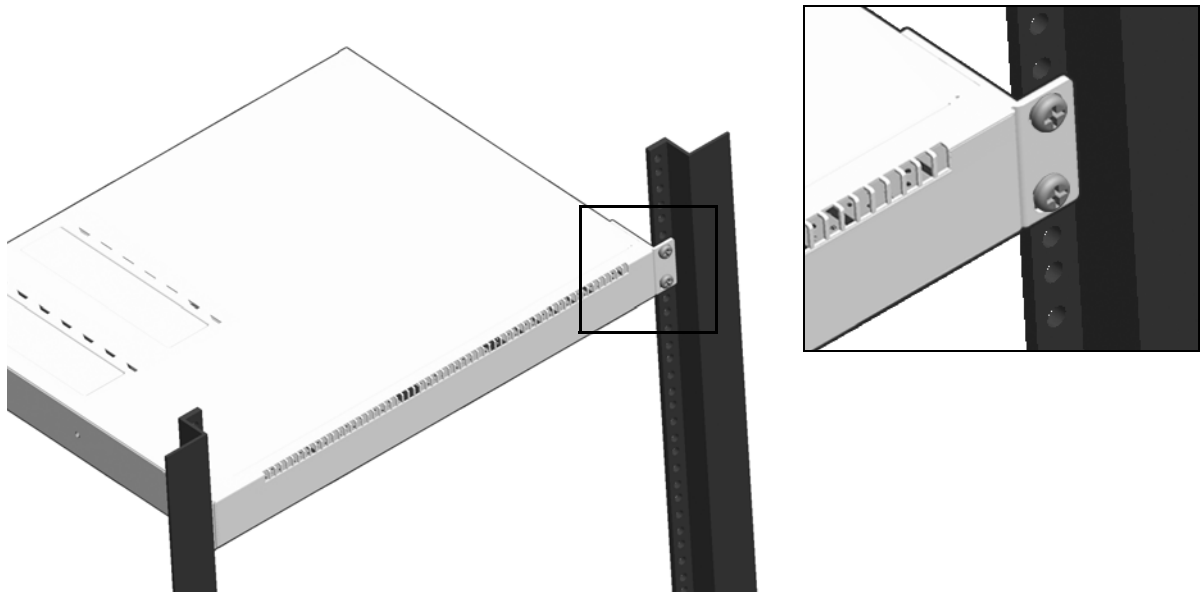

Standalone (Non-Rack Mounted) Installations

The chassis can also be placed unmounted on a stable, flat surface as a standalone unit. Be sure that the surface can accommodate the full, populated weight of all switches being installed. (Approximate chassis weights are provided in the technical specifications tables in the [“OmniSwitch 6860 Chassis Details”](#) section.)

Be sure that adequate clearance has been provided for chassis airflow and that you have placed the chassis within reach of all required AC outlets. For recommended airflow allowances, refer to [page 3-22](#).

To prepare the chassis for tabletop installations, follow the steps below:

- 1** Insert the four (4) rubber feet (provided separately in the switch packaging) into the holes in the bottom panel of the chassis.
- 2** Place the switch on the tabletop “right side up.”

Note. Never attempt to operate a switch while it is placed on its top or side.

- 3** Connect network and management cables as needed.

Power Supplies

OmniSwitch 6860 switches use four (4) power supply types:

Model	Chassis Supported
OS6860-BP 150W AC Non-PoE PSU	OS6860-24, OS6860E-24, OS6860-48, OS6860E-48, OS6860E-U28
OS6860-BP-D 150W DC Non-PoE PSU	OS6860-24, OS6860E-24, OS6860-48, OS6860E-48, OS6860E-U28
OS6860-BP-PH 600W AC PoE PSU	OS6860-P24, OS6860E-P24
OS6860-BP-PX 920W AC PoE PSU	OS6860-P48, OS6860E-P48

OmniSwitch 6860 power supplies are located at the rear of the switch chassis. Refer to [“OmniSwitch 6860 Chassis Details”](#) for more information on component locations. Two slots are provided. If a second power supply is installed, it will assume a standby role.

Please note that the OS6860 does not provide an on/off switch. Connecting an installed power supply to a power source will boot the switch. Likewise, disconnecting all installed power supplies from a power source will power off the switch.

Dying Gasp

If the switch loses all power it will maintain power long enough to send a Dying Gasp message before completely shutting down. An SNMP trap, Syslog message and Link OAM PDUs will be generated.

Scenarios

A Dying Gasp event will be generated in the following scenarios:

- Primary power supply failure (if only power supply present)
- Primary power supply failure and then backup power supply failure
- Backup power supply failure and then primary power supply failure
- When a **reload** command is issued
- When a **takeover** command is issued

Note. Connect each power supply to a separate independent power source to avoid simultaneous power failures.

SNMP Trap

As soon as the power failure is detected, an SNMP trap is sent to the first three configured SNMP stations. The trap includes the following information:

- Slot number
- Power supply type (primary/backup)
- Time of the failure

Use the [snmp station](#) command and refer to the SNMP Configuration chapter for information on configuring an SNMP station.

Syslog Message

As soon as the power failure is detected, the following Syslog message is sent to the first four configured Syslog servers, along with the time of the failure:

```
Dying Gasp Power Failure Event Occurred
```

Use the [swlog output socket](#) command to add a Syslog station. Refer to the *Using Switch Logging Configuration* chapter in the *Network Configuration Guide* for information on configuring a Syslog server.

OS6860-BP 150W Power Supply

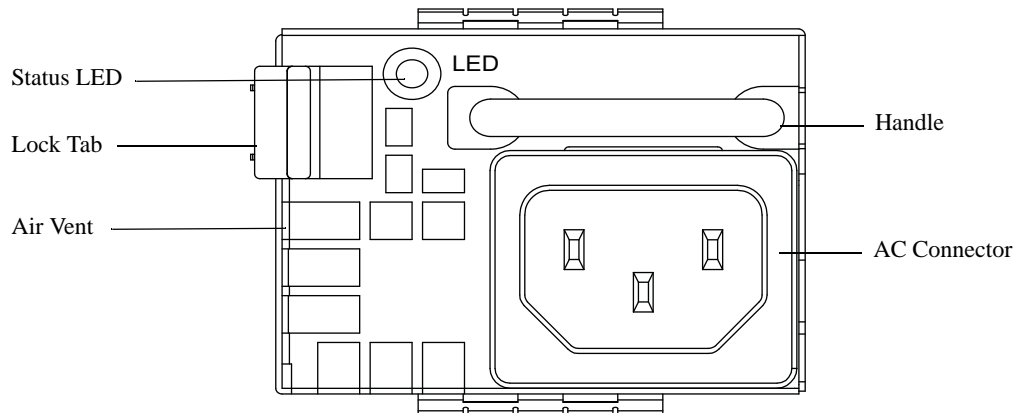

OS6860-BP 150W AC Power Supply Front Panel

Model	OS6860-BP
Models Supported	OS6860-24, OS6860E-24, OS6860-48, OS6860E-48
Input Voltage/Current	90 V to 136 V AC /3 A 180 V to 264 VAC /1.5 A
Input Frequency	47 Hz to 63 Hz
Max. Output Power/Current	150 W/12.5 A

OS6860-BP LED States

LED State	Description
Solid Green	The power supply is operating normally and providing power
Flashing Green	The power supply is on standby and can provide power to the chassis if power supply failover should occur
Flashing Red	No AC power is being provided to this power supply (but another power supply is installed and operating in the adjacent power supply bay)
Flashing Green/Red	Power supply warning
Solid Red	Power supply failure
Off	No AC power is being provided to any power supply installed in the chassis; all power supplies are effectively off

OS6860-BP-D 150W DC Power Supply

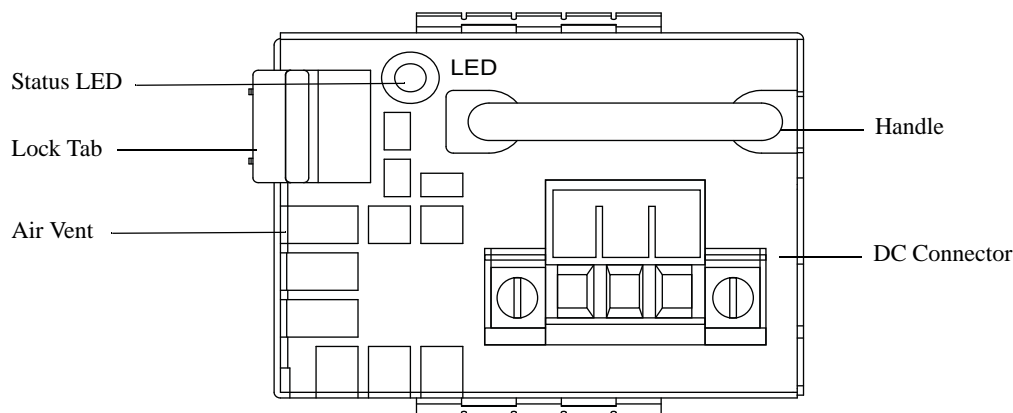

OS6860-BP-D 150W DC Power Supply Front Panel

Model	OS6860-BP-D
Models Supported	OS6860-24, OS6860E-24, OS6860-48, OS6860E-48
Input Voltage/Current	-36 V to -72 V DC/1.8 A to 6 A
Max. Output Power/Current	150 W/12.5 A

OS6860-BP-D LED States

LED State	Description
Solid Green	The power supply is operating normally and providing power
Flashing Green	The power supply is on standby and can provide power to the chassis if power supply failover should occur
Flashing Red	No AC power is being provided to this power supply (but another power supply is installed and operating in the adjacent power supply bay)
Flashing Green/Red	Power supply warning
Solid Red	Power supply failure
Off	No power is being provided to any power supply installed in the chassis; all power supplies are effectively off

OS6860-BP-PH 600W Power Supply

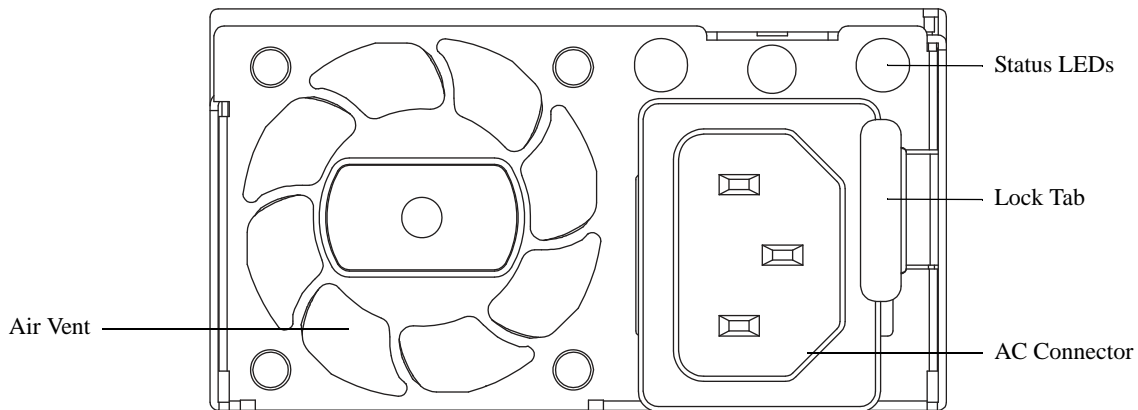

OS6860-BP-PH 600W AC Power Supply Front Panel

Model	OS6860-BP-PH
Models Supported	OS6860-P24, OS6860E-P24
Input Voltage/Current	90 V to 136 V AC /8.5 A 180 V to 264 V AC/4.25 A
Input Frequency	47 Hz to 63 Hz
Max. Output Power/Current	600 W/11 A
Max. Output for System Power	150W
Max. Output for PoE Power	450W

Note. Mixing different wattage power supplies (e.g., 600W and 920W) in a switch chassis is not supported. Redundant power supplies must be like models.

Load Sharing Support. When two 600W PoE power supplies are installed, each power supply provides electrical load sharing for PoE. For example, two 600W power supplies provide 450W + 450W (or 900W) in total PoE power.

OS6860-BP-PH LED States

LED State	Description
AC OK LED Solid Green	AC power is good
AC OK LED Solid Red	There is an AC power issue
DC OK LED Solid Green	DC power is good
DC OK LED Solid Red	There is a DC power issue

OS6860-BP-PX 920W Power Supply

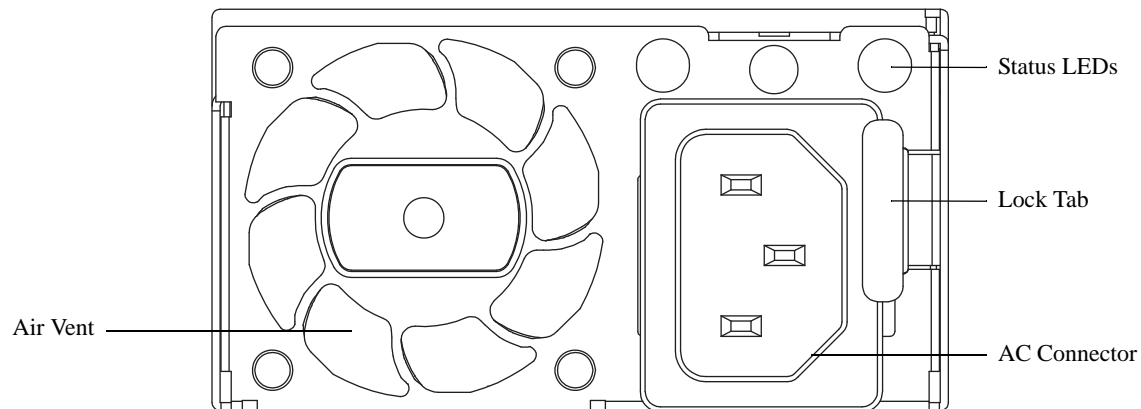

OS6860-BP-PX 920W AC Power Supply Front Panel

Model	
Models Supported	OS6860-P48, OS6860E-P48
Input Voltage/Current	90 V to 136 V AC/13 A 180 V to 264 V AC/6.5 A
Input Frequency	47 Hz to 63 Hz
Max. Output Power/Current	920 W/16.88 A
Max. Output for System Power	140W
Max. Output for PoE Power	780W

Note. Mixing different wattage power supplies (e.g., 600W and 920W) in a switch chassis is not supported. Redundant power supplies must be like models.

Load Sharing Support. When two 920W PoE power supplies are installed, each power supply provides electrical load sharing for PoE. For example, two 920W power supplies provide 780W + 780W (or 1560W) in total PoE power.

OS6860-BP-PX LED States

LED State	Description
AC OK LED Solid Green	AC power is good
AC OK LED Solid Red	There is an AC power issue
DC OK LED Solid Green	DC power is good
DC OK LED Solid Red	There is a DC power issue

DC Power Supply Connections

Connecting a DC Cable Harness to the Chassis Power Supply

When plugging in the cable, insert the connector end of the cable harness into the power supply connector until it clicks firmly into place. This is an indication that the connector is secure and properly seated.

Connecting a DC Cable Harness to the DC Power Source

Safety Guidelines

Before connecting the DC cable to a power source, be sure to follow these important guidelines:

- Connect to a reliably ground -48VDC Selv source.
- The branch circuit overcurrent protection must be rated 15A.
- Use 12AWG copper conductors.
- A readily accessible disconnect device that is suitably approved and rated shall be incorporated in the field wiring.
- It must be installed in a restricted access location.

Primary Ground Information

The product has been designed to be installed in a Common Bonding Network (CBN). The pin of the Green/Yellow ground lead in the three pin cable connector is connected to the ground connector on the DC power supply, which is identified by a Grounding symbol. The Green/Yellow lead wire at the other end of the cable must be connected to a proper earth ground point.

The rear chassis has two ground holes. To properly ground the equipment, connect a Panduit Corporation UL listed Lug, (Part number LCD8-10A-L) to the two threaded holes located at the rear, insert two 10-32, 3/8" threaded pan head screws into these ground holes, and connect them to a proper earth ground point, using protective earthing conductor wire and 8AWG copper conductors.

Connection Details

For DC power supply units, make the following power connections:

Connect the power supply using the supplied DC cable. The cable consists of three 12AWG wires (Green/Yellow, Black, Red).

One end of the cable has a three pin connector in a plastic housing that is inserted into a three pin input connector on the power supply. The other end of the cable is connected to a fuse panel or other source of -48VDC power.

Observe proper polarity when connecting to a fuse panel. The cable wire leads must be connected as follows:

- Green/yellow - ground
- Black - return
- Red - -48VDC

Note. The battery return conductor is an Isolated DC Return (DC-1).

Installing Power Supplies

Note. The power supply shown in the following diagrams is a OS6860-BP-PH/OS6860-BP-PX unit. However, comparable installation and removal steps also apply to OS6860-BP and OS6860-BP-D power supply units, as well as the OS6860 FANTRAY NONPOE Fan Tray (see [page 3-40](#)).

- 1 Insert the power supply into a power supply bay at the rear of the chassis and slide it back until it is securely seated in the chassis backplane.

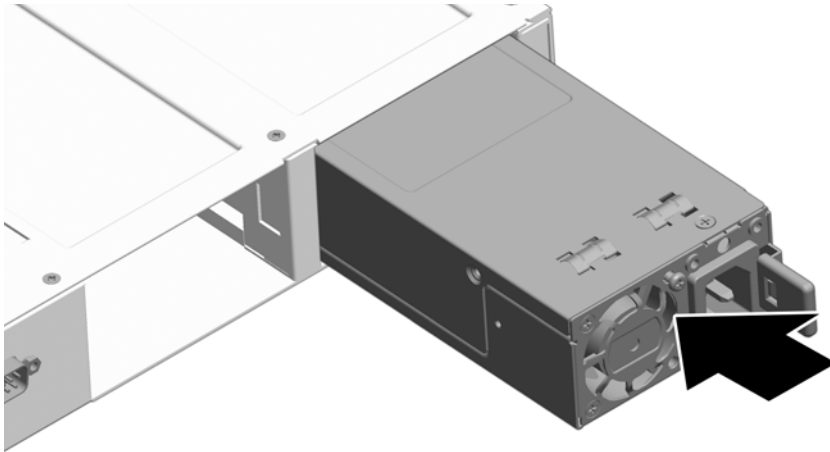

When the connector is fully seated, the lock tab will click and hold the power supply in place.

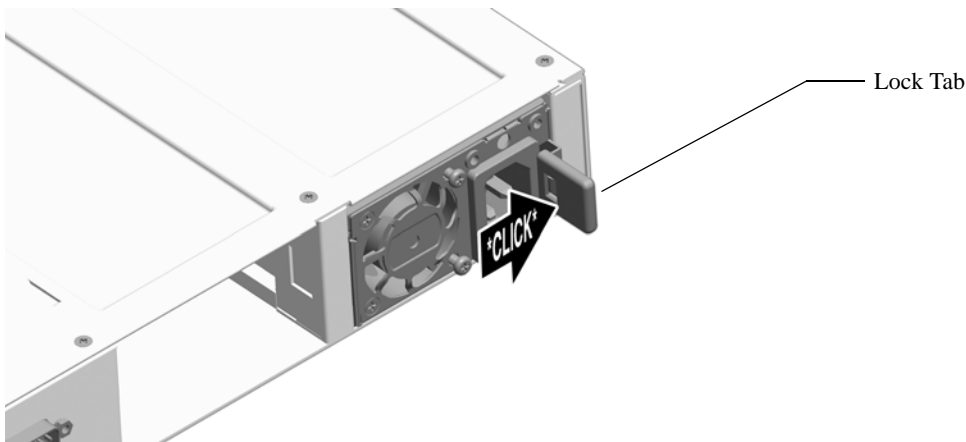

- 2 Plug the power cord (provided) into the power supply's socket.

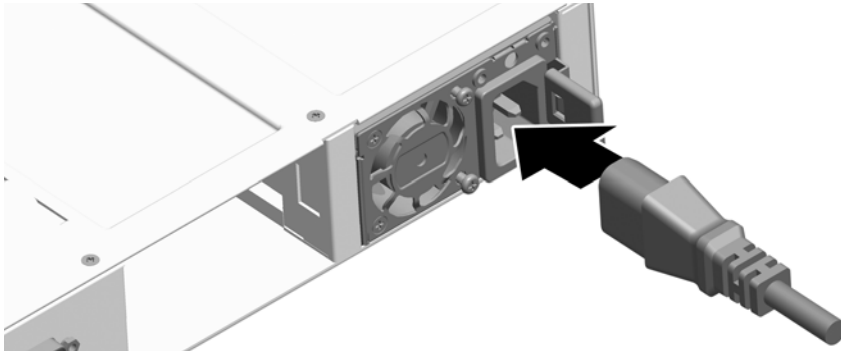

Note. The chassis *does not* provide an on/off switch. Connecting a the power supplies to a power source will boot the switch.

Removing Power Supplies

1 When removing a power supply, first disconnect the power cord from the power source. Once the power cord is disconnected, pull the power cord out of the power supply housing.

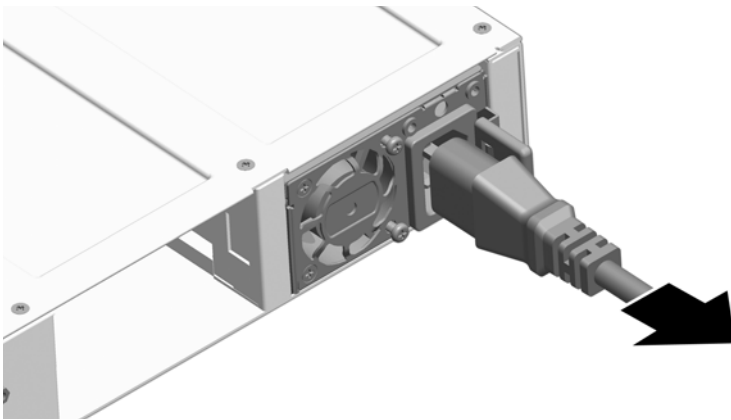

2 Pressing the lock tab toward the center of the power supply, as shown, will free the power supply from the chassis.

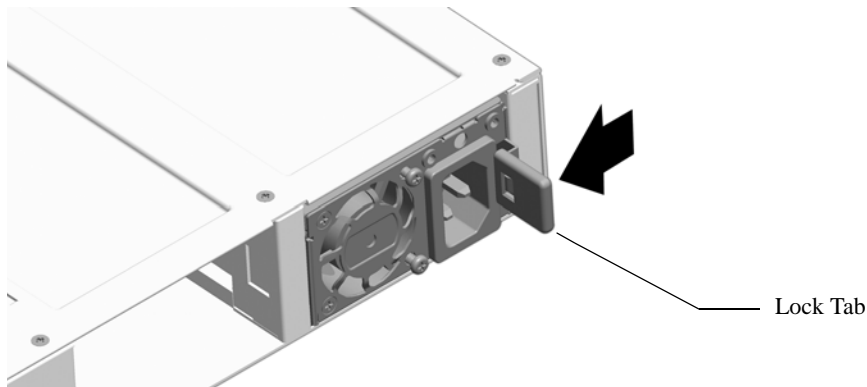

- 3 While pressing the lock tab, pull the power supply straight back and out of the chassis slot.

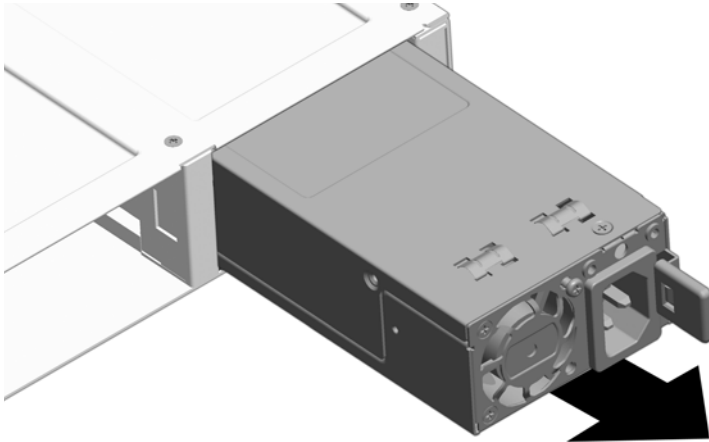

Note. If you are not replacing the power supply, be sure to install a blank cover panel over the empty power supply bay.

Grounding the Chassis

The switch has a grounding lug located on the rear of the chassis. This lug uses 10-32 screws and is surrounded by a small paint-free area, which provides metal-to-metal contact for a ground connection.

Use this connector to supplement the ground provided by the AC power cord. To do so, install a Panduit Grounding Lug (type LCD8-10A-L) using 8AWG copper conductors to the paint-free area.

Refer to the rear chassis views on [page 3-2](#) for location details.

OS6860 FANTRAY NONPOE Fan Tray

The OS6860 FANTRAY NONPOE provides supplemental system cooling for non-PoE OS6860 switches connected to the OmniSwitch Backup Power Shelf/System (BPS).

Note. For information on installing or removing the OS6860 FANTRAY NONPOE unit, follow the steps outlined for power supplies beginning on [page 3-35](#).

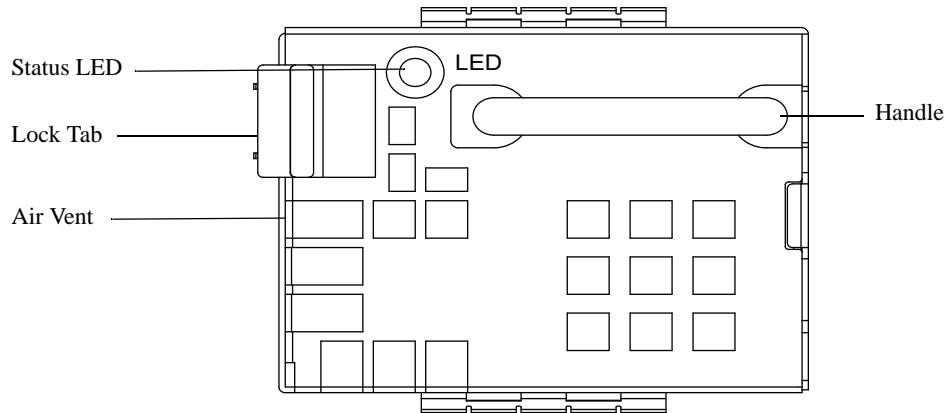

OS6860 FANTRAY NONPOE Front Panel

Model	OS6860 FANTRAY NONPOE
Models Supported	OS6860-24, OS6860E-24, OS6860-48, OS6860E-48, OS6860E-U28

OS6860 FANTRAY NONPOE LED States

LED State	Description
Solid Green	Fan tray is receiving power and operating normally
Off	The fan tray is off or a failure has occurred

Monitoring Chassis Components

Viewing Chassis Slot Information

To view basic slot information, enter the show module command at the CLI prompt:

```
-> show module
```

To view more detailed information, use the show module long command:

```
-> show module long
```

Monitoring Chassis Temperature

The operating temperature of your switch is a critical factor in its overall operability. In order to avoid a temperature-related system failure, your switch must always run at a temperature within the specified operating temperature range.

To avoid chassis over-temperature conditions, follow the important chassis airflow recommendations on [page 3-22](#).

To check the switch's current temperature status, use the **show temperature** command. For example:

```
-> show temperature
Chassis/Device | Current | Range | Danger | Thresh | Status
-----+-----+-----+-----+-----+-----
1/CMMA         | 54      | 15-93 | 93     | 96     | UNDER THRESHOLD
1/Slot1        | 54      | 15-93 | 93     | 101    | UNDER THRESHOLD
2/CMMA         | 39      | 15-85 | 85     | 88     | UNDER THRESHOLD
2/Slot1        | 39      | 15-85 | 85     | 101    | UNDER THRESHOLD
```

For more information about this command, see the “Chassis Management and Monitoring Commands” chapter in the *OmniSwitch CLI Reference Guide*.

Temperature Errors

The switch monitors the ambient air temperature at all times via an onboard sensor. If an over-temperature condition occurs, there are two different levels of error severity:

- Warning threshold has been exceeded
- Danger threshold has been exceeded

Warning Threshold

If the temperature exceeds the switch's user-configurable warning threshold, the switch sends out a trap. Traps are printed to the console in the form of text error messages.

When the warning threshold has been exceeded, switch operations remain active. However, it is recommended that immediate steps be taken to address the over-temperature condition.

Addressing warning threshold temperature conditions may include:

- Checking for a chassis airflow obstruction
- Checking the ambient room temperature
- Verifying that the warning threshold has not been manually set too low.

Temperature Danger Threshold

If the chassis ambient air temperature rises above the danger threshold, the switch will power off until the temperature conditions have been addressed and the switch is manually booted. The danger threshold is factory-set and cannot be configured by the user.

Addressing danger threshold temperature conditions may include:

- Checking for a chassis airflow obstruction
- Checking the ambient room temperature

4 Managing Power over Ethernet (PoE)

Power over Ethernet (PoE) provides inline power directly from the switch's Ethernet ports. Powered Devices (PDs) such as IP phones, wireless LAN stations, Ethernet hubs, and other access points can be plugged directly into the Ethernet. From these RJ-45 the devices receive both electrical power and data flow.

As the feature reduces devices' dependence on conventional power sources, PoE eliminates many restrictions that traditional electrical considerations have imposed on networks.

In a PoE configuration, Power Source Equipment (PSE) detects the presence of a PD and provides an electrical current that is conducted along the data cable. The PD operates using the power received via the Ethernet data cable; no connection to an additional power source (e.g., an AC wall socket) is required.

Note on Terminology. There are several general terms used to describe the feature, PoE. The terms *Power over Ethernet (PoE)*, *Power over LAN (PoL)*, *Power on LAN (PoL)*, and *Inline Power* are synonymous terms used to describe the powering of attached devices via Ethernet. For consistency, this chapter and the *CLI Command Reference Guide* refer to the feature as *Power over Ethernet (PoE)*.

Additional terms, such as *Powered Device (PD)* and *Power Source Equipment (PSE)* are not synonymous with PoE, but are directly related to the feature:

- *PD* refers to any attached device that uses a PoE data cable as its only source of power. Examples include access points, IP telephones, Ethernet hubs, wireless LAN stations, etc.
- *PSE* refers to power sourcing equipment, which provides power to a single link section. PSE main functions include searching the PD, optionally classifying the PD, supplying power to the link section only if the PD is detected, monitoring the power on the link section, and scaling power back to detect level when power is no longer requested or required.

As the switches fully support 10/100/1000 Ethernet connectivity, you may also attach non-PD equipment, such as computer workstations, printers, servers, etc. to the PoE ports.

Important. Alcatel-Lucent recommends that PoE-enabled switches with attached IP telephones should have operational power supply redundancy at all times for 911 emergency requirements. In addition, both the switch and the power supply should be plugged into an Uninterruptible Power Source (UPS).

In This Chapter

This chapter provides specifications and descriptions of hardware and software used to provide PoE for attached devices.

The chapter also provides information on configuring PoE settings on the switch through the Command Line Interface (CLI). CLI commands are used in the configuration examples; for more details about the syntax of commands, see the *OmniSwitch CLI Reference Guide*. Topics and configuration procedures described in this chapter include:

- Power over Ethernet Specifications on [page 4-3](#)
- Viewing Power Status on [page 4-3](#)
- Configuring Power over Ethernet Parameters on [page 4-3](#)
- Understanding Priority Disconnect on [page 4-8](#)
- Monitoring Power over Ethernet via the CLI on [page 4-11](#)

Note. You can also monitor all chassis components and manage many chassis features, including Power over Ethernet, with WebView, Alcatel-Lucent's embedded web-based device management application. WebView is an interactive and easy-to-use GUI that can be launched from the OmniVista or a web browser. Please refer to *WebView's Online Documentation* for more information.

Power over Ethernet Specifications

The table below lists general specifications for Alcatel-Lucent's Power over Ethernet support. For more detailed power supply and Power Source Equipment (PSE) specifications, refer to [Chapter 3, "Chassis and Power Supplies."](#)

IEEE Standards supported	IEEE 802.3; 802.af; 802.3at
PoE Class Detection	Supported
Default PoE administrative status	Enabled
Default PoE operational status	Disabled (PoE must be activated on a slot-by-slot basis via the lanpower slot service command.)
Platforms supporting PoE	OS6860-P24; OS6860-P48; OS6860E-P24; OS6860E-P48
Default inline power per port	OS6860 models: 30000 milliwatts on all ports OS6860E (Enhanced) models: 60000 milliwatts on ports 1 through 4; 30000 milliwatts on ports 5 and higher
Range of inline power per port	OS6860 models: 3000-30000 milliwatts on all ports OS6860E (Enhanced) models: 3000-60000 milliwatts on ports 1 through 4; 3000-30000 milliwatts on ports 5 and higher
Default PoE power per slot	920W power supply- 780W 600W power supply - 450W
Maximum PoE power per slot	920W power supply- 780W 600W power supply - 450W

Viewing Power Supply Status

To view the type and status for installed power supplies, use the [show powersupply](#) command:

```
-> show powersupply
      Total      PS
Chassis/PS  Power      Type      Status      Location
-----+-----+-----+-----+-----
1/1         920         AC         UP           Internal
      Total    920
```

Viewing PoE Status

To view current PoE status and settings, use the **show lanpower slot** command:

```
-> show lanpower slot 1/1
Port Maximum(mW) Actual Used(mW) Status Priority On/Off Class Type
-----+-----+-----+-----+-----+-----+-----+-----
  1      60000          0    Powered Off    Low    OFF    .
  2      60000          0    Powered Off    Low    OFF    .
  3      60000          0    Powered Off    Low    OFF    .
  4      60000          0    Powered Off    Low    OFF    .
  5      30000          0    Powered Off    Low    OFF    .
  6      30000          0    Powered Off    Low    OFF    .
  7      30000          0    Powered Off    Low    OFF    .
  8      30000          0    Powered Off    Low    OFF    .
  9      30000          0    Powered Off    Low    OFF    .
 10      30000          0    Powered Off    Low    OFF    .
...
 45      30000          0    Powered Off    Low    OFF    .
 46      30000          0    Powered Off    Low    OFF    .
 47      30000          0    Powered Off    Low    OFF    .
 48      30000          0    Powered Off    Low    OFF    .
```

```
ChassisId 1 Slot 1 Max Watts 780
0 Watts Total Power Budget Used
780 Watts Total Power Budget Available
1 Power Supplies Available
BPS power: Not Available
```

Power over Ethernet Defaults

The following table lists the defaults for PoE configuration:

Parameter Description	Command(s)	Default Value/Comments
PoE operational status	lanpower slot service	Disabled
Total power available to a port	lanpower power	OS6860 models: 30000 milliwatts on all ports OS6860E (Enhanced) models: 60000 milliwatts on ports 1 through 4; 30000 milliwatts on ports 5 and higher
Total power available to an entire slot	lanpower slot maxpower	920W power supply- 780W 600W power supply - 450W
Power priority level for a port	lanpower priority	low
Capacitor detection method	lanpower capacitor-detection	Disabled
Priority disconnect status	lanpower slot priority-disconnect	Enabled

Understanding and Modifying the Default Settings

The sections below provide information on each of the key components within the Power over Ethernet software. They include information on PoE-related CLI commands. For detailed information on PoE-related commands, refer to the *OmniSwitch CLI Reference Guide*.

Note. PoE units support different wattage power supplies. If unlike power supplies are mixed or if an unsupported power supply is used, a console message and a trap are generated.

PoE Class Detection

Powered devices can be classified into different classes as shown in the table below. Class detection allows for automatic maximum power adjustment based on the power class detected. This will prevent the switch from delivering more than the maximum power allowed based on a device's class.

During class detection, the switch will allocate the maximum amount of power allowed based on the class detected. Once powered, if the device uses less than the maximum, the remaining power will be made available for other devices.

Class	Usage Classification	Current (mA)	Power Range (Watts)	Class Description
0	Default	0-4	0.44-30.00	Unimplemented
1	Optional	9-12	0.44-3.84	Very Low Power
2	Optional	17-20	3.84-6.49	Low Power
3	Optional	26-30	6.49-12.95	Mid Power
4	Optional	36-44	12.95- 30.00	High Power

Although class-detection is disabled by default, the OS6860 still provides power to incoming PDs (if available in the power budget). However, to strictly enforce class detection as specified in the 802.3at standard, class detection must be enabled using the **lanpower slot class-detection** command.

Enabling class detection will reset all PoE ports on the chassis.

PoE Operational Status

Enabling PoE

By default, Power over Ethernet is *administratively enabled* in the switch's system software. However, in order to physically activate PoE, you must issue the **lanpower slot service** command on a slot-by-slot basis before any connected PDs will receive inline power.

To activate power to PoE-capable in a switch, enter the corresponding slot number only. For example:

```
-> lanpower slot 2/1 service start
```

If power to a particular port has been administratively disconnected, you can reactivate power to the port using the **lanpower port admin-state** command. For example:

```
-> lanpower port 2/1/1-24 admin-state enable
```

Note. You cannot use the **lanpower port admin-state** command to initially activate PoE on a port. This syntax is intended only to reactivate power to those that have been disconnected via the **lanpower slot service** command. To initially activate PoE, you must use the **lanpower slot service** command as described above.

Disabling PoE

To disable PoE on a particular port, use the **lanpower port admin-state** command. For example:

```
-> lanpower port 1/1/12 admin-state disable
```

To disable PoE for *all PoE-capable ports in a slot*, use the **lanpower slot service** command. For example:

```
-> lanpower slot 1/1 service stop
```

Configuring the Total Power Available to a Port

By default, each port is authorized by the system software to use up to a maximum amount of milliwatts to power any attached device.

You can either increase or decrease this value based on the allowed ranges.

Increasing the total power available to an individual port may provide a more demanding Powered Device (PD) with additional power required for operation. Decreasing the total power available to a port helps to preserve inline power and assists in the overall management of the switch's power budget.

To increase or decrease the total power available to an individual port, use the **lanpower power** command. Since you are setting the power allowance for an individual port, you must specify *chassis/slot/port* values in the command line. For example, the syntax

```
-> lanpower port 1/1/24 power 3000
```

reduces the power allowance on port 24 to 3000 milliwatts. This new value is now the maximum amount of power the port can use to power any attached device (until the value is modified by the user).

Configuring the Total Power Available to a slot

Like the maximum port power allowance, the system software also provides a maximum *slot-wide* power allowance. By default, each slot is authorized by the system software to use a number of watts to power all devices connected to its ports depending on which power supply is used.

As with the maximum port power allowance, the user can either increase or decrease this value based on the allowed ranges.

Important. Decreasing the slot-wide power could cause lower priority ports to lose power if the new value is less than the total PoE power currently being consumed.

To increase or decrease the total power available to a slot, use the **lanpower slot maxpower** command. Since you are setting the power allowance for an individual slot, you must specify a *chassis/slot* value in the command line. For example, the syntax

```
-> lanpower slot 3/1 maxpower 400
```

reduces the power allowance of chassis 3, slot 1 to 400 watts. This value is now the maximum amount of power the slot can use to power all attached devices (until the value is modified by the user).

Note. Changing the maximum power available to a slot or port **does not** reserve or immediately allocate that power. These settings are only used for configuring a maximum amount of power that may be used, any unused power is still available and remains a part of the overall PoE budget.

Setting Port Priority Levels

As not all Powered Devices (PDs) connected to the switch have the same priority within a network setting, the OmniSwitch allows the administrator to specify priority levels on a port-by-port basis. Priority levels include low, high, and critical. The default priority level for a port is low.

- **Low.** This default value is used for port(s) that have low-priority devices attached. In the event of a power management issue, inline power to low-priority is interrupted first (i.e., before critical and high-priority).
- **High.** This value is used for port(s) that have important, but *not* mission-critical, devices attached. If other ports in the chassis have been configured as critical, inline power to high-priority is given second priority.
- **Critical.** This value is used for port(s) that have mission-critical devices attached, and therefore require top (i.e., critical) priority. In the event of a power management issue, inline power to critical is maintained as long as possible.

To change the priority level for a particular port, use the **lanpower priority** command. Since the switch allows you to set priority levels on a port-by-port basis, be sure to specify *chassis/slot/port* information in the command line. For example, the syntax

```
-> lanpower port 1/1/6 priority critical
```

changes the priority value of port 6 to the highest priority level of critical. Now that the default value has been reconfigured, this port should be reserved for those PDs that are mission critical for network operations.

Setting the Capacitor Detection Method

By default, the capacitor detection method is disabled. To enable it, use the **lanpower capacitor-detection**. For example:

```
-> lanpower slot 3/1 capacitor-detection enable
```

Note. The capacitive detection method should only be enabled to support legacy IP phones. This feature is *not* compatible with IEEE specifications. Please contact your Alcatel-Lucent sales engineer or Customer Support representative to find out which Alcatel-Lucent IP phones models need capacitive detection enabled.

Understanding Priority Disconnect

The priority disconnect function differs from the port priority function described on [page 4-7](#) in that it applies only to *the addition of powered devices (PDs) in tight power budget conditions*. Priority disconnect is used by the system software in determining whether an incoming PD will be granted or denied power when there are too few watts remaining in the PoE power budget for an additional device. For example, if there are only 2 watts available in the current PoE power budget and a user plugs a 3.5W powered device into a PoE port, the system software must determine whether the device will be powered on. Based on priority disconnect rules, in some cases one or more existing devices may be powered down in order to accommodate the incoming device. In other cases, the incoming device will be denied power.

Priority disconnect rules involve the port priority status of an incoming device (i.e., low, high, and critical), as well as the port's physical port number (i.e., 1–24). Understanding priority disconnect rules is especially helpful in avoiding power budget deficits and the unintentional shutdown of mission-critical devices when PDs are being added in tight power budget conditions. For detailed information on how priority disconnect uses port priority and port number criteria for determining the power status of incoming PDs, refer to the illustrated examples on [pages 4-9 through 4-10](#).

Reminder. Priority disconnect applies only when there is inadequate power remaining in the power budget for an incoming device.

Note. For OS6860 switches using 920W power supplies, priority disconnect supports up to a maximum of 780W of PoE power (per power supply installed). For switches using 600W power supplies, priority disconnect supports up to a maximum of 450W of PoE power (per power supply installed).

For information on setting the priority disconnect status, refer to the section below. For information on setting the port priority status (a separate function from priority disconnect), refer to [“Setting Port Priority Levels” on page 4-7](#).

Setting Priority Disconnect Status

By default, priority disconnect is *enabled* in the switch's system software. For information on changing the priority disconnect status, refer to the information below.

Disabling Priority Disconnect

When priority disconnect is disabled and there is inadequate power in the budget for an additional device, power will be denied to *any* incoming PD, regardless of its port priority status (i.e., low, high, and critical) or physical port number (i.e., 1–24).

To disable priority disconnect, use the [lanpower slot priority-disconnect](#) command. For example:

```
-> lanpower slot 2/1 priority-disconnect disable
```

Enabling Priority Disconnect

To enable priority disconnect, use the [lanpower slot priority-disconnect](#) command. For example:

```
-> lanpower slot 2/1 priority-disconnect enable
```

Priority Disconnect is Enabled; Same Priority Level on All PD

Reminder. Priority disconnect examples are applicable only when there is inadequate power remaining to power an incoming device.

When a PD is being connected to a port with the same priority level as all other in the slot, the physical port number is used to determine whether the incoming PD will be granted or denied power. Due to the support of different PoE standards and PoE hardware on each platform the internal port priority is different for each platform. The following tables should be used to determine PoE priority:

OS6860 Physical Port - 24 Port Models	24 (Highest) -> 1 (Lowest)
OS6860 Physical Port - 48 Port Models	48 (Highest) -> 1 (Lowest)

PoE Physical Port Priority

Priority Disconnect is Enabled; Incoming PD Port has Highest Priority Level

Reminder. Priority disconnect examples are applicable only when there is inadequate power remaining to power an incoming device.

When a PD is being connected to a port with a *higher priority level* than all other in the slot, the incoming PD will automatically be granted power over the other devices, regardless of its physical port number.

In order to avoid a power budget deficit, another port in the slot is disconnected. In determining which port to power off, the system software first selects the port with the lowest configured priority level. For example, if a *critical priority* device is being added to a slot in which five existing devices are attached to *high priority* and one device is attached to a *low priority* port, the low priority port is automatically disconnected, regardless of its physical port number.

If all existing devices are attached to with the same lower priority level, the system software disconnects the port with both the lowest priority level *and* the highest priority physical port number. For example, if a critical priority device is being added to a slot in which six existing devices are attached to high priority, the high priority port with the lowest physical port priority number is automatically disconnected.

Priority Disconnect is Enabled; Incoming PD Port has Lowest Priority Level

Reminder. Priority disconnect examples are applicable only when there is inadequate power remaining to power an incoming device.

When a PD is being connected to a port with a *lower priority level* than all other in the slot, the incoming PD will be denied power, regardless of its physical port number. Devices connected to other higher-priority will continue operating without interruption.

Priority Disconnect is Disabled

Reminder. Priority disconnect examples are applicable only when there is inadequate power remaining to power an incoming device.

When priority disconnect is disabled, power will be denied to *any* incoming PD, regardless of its port priority status (i.e., low, high, and critical) or physical port number (i.e., 1–24).

Monitoring Power over Ethernet via CLI

To monitor current PoE statistics and settings, use the **show lanpower slot** command. The command output displays a list of all current PoE-capable, along with the following information for each port:

- Maximum power available to the port, in milliwatts
- Actual power used by the port
- Current port status
- Power priority status
- Power on/off status

Aggregate slot and chassis management information is also displayed. This information includes:

- Maximum watts available to the corresponding slot
- Amount of power budget remaining for PoE modules
- Total amount of power remaining for additional switch functions

When entering the **show lanpower** command, you must include a valid slot number in the command line syntax. For example:

```
-> show lanpower 1
Port Maximum(mW) Actual Used(mW) Status Priority On/Off Class
-----+-----+-----+-----+-----+-----+-----
  1      30000      12500    Powered On    Low    ON      0
  2      30000       1800    Powered On    Low    ON      1
  3      30000       3500    Powered On    Low    ON      2
  4      30000       9800    Powered On    Low    ON      3
  5      30000      25000    Powered On    Low    ON      4
  6      30000         0    Undefined    Low    ON      -
  7      30000         0    Undefined    Low    ON      -
  8      30000         0    Undefined    Low    ON      -
  9      30000         0    Undefined    Low    ON      -
```

(output truncated)

```
21      30000         0    Undefined    Low    ON      -
22      30000         0    Undefined    Low    ON      -
23      30000         0    Undefined    Low    ON      -
24      30000         0    Undefined    Low    ON      -
```

```
Slot 3 Max Watts 150
1 Power Supplies Available
```

Note. For detailed information on **show lanpower** command output, refer to the *OmniSwitch CLI Reference Guide*.

A Regulatory Compliance and Safety Information

This appendix provides information on regulatory agency compliance and safety for OmniSwitch 6860 switches.

Declaration of Conformity: CE Mark

This equipment is in compliance with the essential requirements and other provisions of Directive 2004/108/EC (EMC), 2006/95/EC (LVD), 91/263/EEC (Telecom Terminal Equipment, if applicable), 1999/5/EC (R&TTE, if applicable).

Français: Cet équipement est conforme aux exigences essentielles et aux autres provisions de la Directive 2004/108/EC (EMC), 2006/95/CE (LVD), 91/263/CEE (équipements terminaux de télécommunications, le cas échéant), 1999/5/EC (R&TTE, le cas échéant).

Deutsch: Diese Ausrüstung erfüllt die wesentlichen Anforderungen und sonstigen Bestimmungen der Richtlinien 2004/108/EG (EMV-Richtlinie), 2006/95/EG (Niederspannungsrichtlinie), 91/263/EWG (Telekommunikationsendeinrichtungen, falls zutreffend), 1999/5/EG (Funkanlagen und Telekommunikationsendeinrichtungen, falls zutreffend).

Español: Este equipo cumple los requisitos esenciales y otras disposiciones de las directivas 2004/108/CE (EMC), 2006/95/CE (LVD), 91/263/CEE (equipos terminales de telecomunicación, si procede), 1999/5/CE (R&TTE, si procede).

Waste Electrical and Electronic Equipment (WEEE) Statement

The product at end of life is subject to separate collection and treatment in the EU Member States, Norway and Switzerland and therefore marked with the following symbol:

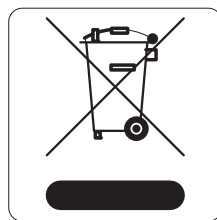

Treatment applied at end of life of the product in these countries shall comply with the applicable national laws implementing directive 2002/96/EC on waste electrical and electronic equipment (WEEE).

China RoHS: Hazardous Substance Table

部件名称 Part Name	有毒和危险品 Toxic and Hazardous Substances or Elements					
	铅 (Pb)	水银 (Hg)	镉 (Cd)	六价铬 (Cr(VI))	多溴化苯 (PBB)	多溴化二苯醚 (PBDE)
电路模块 (Circuit Boards)	X	○	○	○	○	○
电缆及电缆组件 (Cables & Cable Accessories)	X	○	○	○	○	○
金属部件 (Metal Parts)	X	○	○	○	○	○
塑料和聚合物部件 (Plastic and Polymeric parts)	○	○	○	○	○	○
可插拔模块 (Pluggable modules)	X	○	○	○	○	○
电池 (Batteries)	○	○	○	○	○	○

本表格依据 SJ/T 11364 的规定编制

○ = 表示该有害物质在该部件所有均质材料中的含量均在 GB/T 26572 规定的限量要求以下 (indicates that the content of the toxic and hazardous substance in all the Homogeneous Materials of the part is below the concentration limit requirement as described in GB/T 26572).

X = 表示该有害物质至少在该部件的某一均质材料中的含量超出 GB/T 26572 规定的限量要求 (indicates that the content of the toxic and hazardous substance in at least one Homogeneous Material of the part exceeds the concentration limit requirement as described in GB/T 26572).

California Proposition 65 Warning

WARNING: This product contains chemicals known to the State of California to cause cancer and birth defects or other reproductive harm.

Products are packaged using one or more of the following packaging materials:

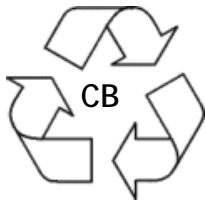

Corrugated Cardboard

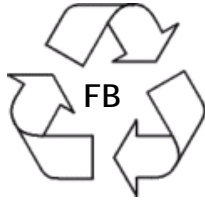

Corrugated Fiberboard



LDPE

Low-Density Polyethylene

Standards Compliance

The product bears the CE mark. In addition it is in compliance with the following other safety and EMC standards.

Note. All hardware switching modules used in an OmniSwitch 6860 switch comply with Class A standards. Modules with copper connectors meet Class A requirements using unshielded (UTP) cables.

Safety Standards

- US UL 60950-1
- IEC 60950-1 Health and Safety
- CAN/CSA-C22.2 No. 60950-1-03
- NOM-019 SCFI, Mexico
- AS/NZ TS-001 and 60950:2000, Australia
- UL-AR, Argentina
- UL-GS Mark, Germany
- CU, EAC, Russia
- EN 60825-1 Laser
- EN 60825-2 Laser
- CDRH Laser
- IEC 60950-1/EN 60950 with all country
- deviations
- IEC 60950-1:2005, Second Edition
- CCC, China*
- ANATEL, Brazil (Contact for availability)
- BSMI, Taiwan (Contact for availability)
- KCC, Korea (Contact for availability)

EMI/EMC Standards

- FCC Part 15:2012, Subpart B, Class A
- ICES-003:2012 Issue 5, Class A
- ANSI C63.4-2009
- FCC CRF Title 47 Subpart B (Class A)
- VCCI (Class A)
- AS/NZS 3548 (Class A)
- CE marking for European countries (Class A)
- EN 55022 (EMI & EMC)
- EN 61000-3-2
- EN 61000-3-3
- EN 55024 (Immunity)
 - EN 61000-4-2
 - EN 61000-4-3
 - EN 61000-4-4
 - EN 61000-4-5
 - EN 61000-4-6
 - EN 61000-4-8
 - EN 61000-4-11
- IEEE 802.3: Hi-Pot Test
(2250 V DC on all Ethernet ports)

Environmental Standards

- ETS 300 019 Storage Class 1.1
- ETS 300 019 Transportation Class 2.3
- ETS 300 019 Stationary Use Class 3.1

FCC Class A, Part 15

This equipment has been tested and found to comply with the limits for Class A digital device pursuant to Part 15 of the FCC Rules. These limits are designed to provide reasonable protection against harmful interference when the equipment is operated in a commercial environment. This equipment generates, uses, and can radiate radio frequency energy and, if not installed and used in accordance with the instructions in this guide, may cause interference to radio communications. Operation of this equipment in a residential area is likely to cause interference, in which case the user will be required to correct the interference at his own expense.

The user is cautioned that changes and modifications made to the equipment without approval of the manufacturer could void the user's authority to operate this equipment. It is suggested that the user use only shielded and grounded cables to ensure compliance with FCC Rules.

If this equipment does cause interference to radio or television reception, the user is encouraged to try to correct the interference by one or more of the following measures:

- Reorient the receiving antenna.
- Relocate the equipment with respect to the receiver.
- Move the equipment away from the receiver.
- Plug the equipment into a different outlet so that equipment and receiver are on different branch circuits.

If necessary, the user should consult the dealer or an experienced radio/television technician for additional suggestions.

Canada Class A Statement

This equipment does not exceed Class A limits per radio noise emissions for digital apparatus, set out in the Radio Interference Regulation of the Canadian Department of Communications.

Avis de conformité aux normes du ministère des Communications du Canada

Cet équipement ne dépasse pas les limites de Classe A d'émission de bruits radioélectriques pour les appareils numériques, telles que prescrites par le Règlement sur le brouillage radioélectrique établi par le ministère des Communications du Canada.

JATE

This equipment meets the requirements of the Japan Approvals Institute of Telecommunications Equipment (JATE).

CISPR22 Class A warning

This is a Class A product. In a domestic environment, this product may cause radio interference. Under such circumstances, the user may be requested to take appropriate countermeasures.

Korea Emissions Statement

A 급 기기 (업무용 방송통신 기자재)
이 기기는 업무용 (A 급) 전자파적합기기로서 판매자 또는 사용자는 이 점을 주의하시기 바라며, 가정외의 지역에서 사용하는 것을 목적으로 합니다.

Class A Equipment (Business equipment)
This equipment is registered for Electromagnetic Conformity Registration as business equipment (A), not home equipment. Sellers or users are required to take caution in this regard.

VCCI

This is a Class A product based on the standard of the Voluntary Control Council for Interference by Information Technology Equipment (VCCI). If this equipment is used in a domestic environment, radio disturbance may arise. When such trouble occurs, the user may be required to take corrective actions.

この装置は、情報処理装置等電波障害自主規制協議会（VCCI）の基準に基づくクラスA情報技術装置です。この装置を家庭環境で使用すると電波妨害を引き起こすことがあります。この場合には使用者が適切な対策を講ずるよう要求されることがあります。

Class A Warning for Taiwan and Other Chinese Markets

This is a Class A Information Product. When used in a residential environment, it may cause radio frequency interference. Under such circumstances, the user may be requested to take appropriate countermeasure.

警告使用者：
這是甲類的資訊產品，在居住的環境中使用時，可能會造成射頻干擾，在這種情況下，使用者會被要求採取某些適當的對策。

Class 1M Laser Warning

CLASS 1M LASER RADIATION WHEN OPEN. DO NOT VIEW DIRECTLY WITH OPTICAL INSTRUMENTS.

Network Cable Installation Warning

Never install exposed network cables outdoors. Install network cables per manufacturer requirements.

Translated Safety Warnings

Blank Panels Warning

Because they regulate airflow and help protect internal chassis components, blank cover plates should remain installed at empty module slots and power supply bays at all times.

Français: Les caches blancs remplissent trois fonctions importantes: ils évitent tout risque de choc électrique à l'intérieur du châssis, ils font barrage aux interférences électromagnétiques susceptibles d'altérer le fonctionnement des autres équipements et ils dirigent le flux d'air de refroidissement dans le châssis. Il est vivement recommandé de vérifier que tous les caches, modules d'alimentation et plaques de protection sont en place avant d'utiliser le système.

Deutsch: Die leeren Modulblenden schützen interne Komponenten und leiten den Luftstrom. Deshalb müssen in allen unbelegten Slots die Modulblenden immer installiert bleiben.

Español: Las tapaderas blancas regulan la circulación de aire y ayudan a proteger componentes internos del chasis y siempre deben estar instaladas en las ranuras vacías del chasis y fuentes de alimentación.

Electrical Storm Warning

To avoid a shock hazard, do not connect or disconnect any cables or perform installation, maintenance, or reconfiguration of this product during an electrical storm.

Français: Ne pas travailler sur le système ni brancher ou débrancher les câbles pendant un orage.

Deutsch: Um elektrische Schläge zu vermeiden dürfen während eines Gewitters and diesem Gerät keine Kabel angeschlossen oder gelöst werden, sowie keinerlei Installationen, Wartungen oder Konfigurationen vorgenommen werden.

Español: Para evitar peligro de descargas, no conecte o desconecte ningún cable, ni realice ninguna instalación, mantenimiento o reconfiguración de este producto durante una tormenta eléctrica.

Installation Warning

Only personnel knowledgeable in basic electrical and mechanical procedures should install or maintain this equipment.

Français: Toute installation ou remplacement de l'appareil doit être réalisée par du personnel qualifié et compétent.

Deutsch: Dieses Gerät soll nur von Personal installiert oder gewartet werden, welches in elektrischen und mechanischen Grundlagen ausgebildet ist.

Español: Estos equipos deben ser instalados y atendidos exclusivamente por personal adecuadamente formado y capacitado en técnicas eléctricas y mecánicas.

Invisible Laser Radiation Warning

Lasers emit invisible radiation from the aperture opening when no fiber-optic cable is connected. When removing cables do not stare into the open apertures. In addition, install protective aperture covers to fiber ports with no cable connected.

Français: Des radiations invisibles à l'œil nu pouvant traverser l'ouverture du port lorsque aucun câble en fibre optique n'y est connecté, il est recommandé de ne pas regarder fixement l'intérieur de ces ouvertures. Installez les caches connecteurs prévus à cet effet.

Deutsch: Die Laser strahlen an der Blendenöffnung unsichtbares Licht ab, wenn keine Glasfaserkabel angeschlossen sind. Blicken Sie nicht in die Öffnungen und installieren Sie unverzüglich die Abdeckungen über den Glasfaseranschlüssen.

Español: Debido a que la apertura del puerto puede emitir radiación invisible cuando no hay un cable de fibra conectado, procurar no mirar directamente a las aperturas para no exponerse a la radiación.

Operating Voltage Warning

To reduce the risk of electrical shock, keep your hands and fingers out of power supply bays and do not touch the backplane while the switch is operating.

Français: Pour réduire tout risque électrique, gardez vos mains et doigts hors des alimentations et ne touchez pas au fond de panier pendant que le commutateur fonctionne.

Deutsch: Um die Gefahr des elektrischen Schlages zu verringern, greifen sie bitte nicht in die Spannungsversorgung und berühren sie nicht die Rückwandplatine während das Gerät arbeitet.

Español: Para reducir el riesgo de descargas eléctricas, no meta sus manos y dedos dentro del chasis de la fuente de alimentación y no toque componentes internos mientras que el interruptor está conectado.

Power Disconnection Warning

Your switch is equipped with multiple power supplies. To reduce the risk of electrical shock, be sure to disconnect all power connections before servicing or moving the unit.

Français: Il se peut que cette unité soit équipée de plusieurs raccordements d'alimentation. Pour supprimer tout courant électrique de l'unité, tous les cordons d'alimentation doivent être débranchés.

Deutsch: Ihr Gerät ist mit mehreren Netzteilen ausgerüstet. Um die Gefahr des elektrischen Schlages zu verringern, stellen sie sicher, daß alle Netzverbindungen getrennt sind bevor das Gerät gewartet oder bewegt wird.

Español: Antes de empezar a trabajar con un sistema, asegurese que el interruptor está cerrado y el cable eléctrico desconectado.

Proper Earthing Requirement Warning

To avoid shock hazard:

- The power cord must be connected to a properly wired and earth receptacle.
- Any equipment to which this product will attached must also be connected to properly wired receptacles.

Français:

Pour éviter tout risque de choc électrique:

- Ne jamais rendre inopérant le conducteur de masse ni utiliser l'équipement sans un conducteur de masse adéquatement installé.
- En cas de doute sur la mise à la masse appropriée disponible, s'adresser à l'organisme responsable de la sécurité électrique ou à un électricien.

Deutsch:

Aus Sicherheitsgründen:

- darf das Netzkabel nur an eine Schutzkontaktsteckdose angeschlossen werden.
- dürfen für den Anschluß anderer Geräte, welche mit diesem Gerät verbunden sind, auch nur Schutzkontaktsteckdosen verwendet werden.

Español:

Para evitar peligro de descargas:

- Para evitar peligro de descargas asegurese de que el cable de alimentación está conectado a una toma de alimentación adecuadamente cableada y con toma de tierra.
- Cualquier otro equipo a cual se conecte este producto también debe estar conectado a tomas de alimentación adecuadamente cableadas.

DC Power Supply Connection Warning

For EMC/EMI, each DC/DC power supply requires that the ground wire is connected from each DC/DC power supply to Common Earth Ground.

Français: Pour EMC/EMI, pour chaque alimentation DC/DC, il est impératif que le fil de terre soit branché à la prise de terre commune.

Deutsch: Zur Erfüllung der EMV-/EMI-Anforderungen muss das Erdungskabel jedes DC/DC-Netzteils an eine gemeinsame Erde angeschlossen werden.

Español: Para EMC/EMI, cada fuente de alimentación de CC/CC requiere que el cable de tierra esté conectado desde cada fuente de alimentación de CC/CC a la conexión a tierra común.

Read Important Safety Information Warning

The *Getting Started Guide* that accompanied this equipment contains important safety information about which you should be aware when working with hardware components in this system. You should read this guide before installing, using, or servicing this equipment.

Français: Avant de brancher le système sur la source d'alimentation, consultez les directives d'installation disponibles dans le "Getting Started Guide".

Deutsch: Der Getting Started Guide, welcher diese Anlage beiliegt, enthält wichtige Sicherheitsinformationen, über die sie sich beim Arbeiten mit den Hardwareeinheiten bewußt sein sollten. Sie sollten diese Hinweise lesen, bevor sie installieren, reparieren oder die Anlage verwenden.

Español: La 'Getting Started Guide' que acompañó este equipo contiene información importante de seguridad sobre la cual usted debe estar enterado al trabajar con los componentes de dotación física en este sistema. Usted debe leer esta guía antes de instalar, usar o mantener este equipo.

Restricted Access Location Warning

This equipment should be installed in a location that restricts access. A restricted access location is one where access is secure and limited to service personnel who have a special key, or other means of security.

Français: Le matériel doit être installé dans un local avec accès limité ou seules les personnes habilitées peuvent entrer.

Deutsch: Die Anlage sollte an einem Standort mit beschränktem Zutritt installiert sein. Ein Standort mit beschränktem Zutritt stellt sicher, daß dort nur Servicepersonal mit Hilfe eines Schlüssels oder eines anderen Sicherheitssystems Zugang hat.

Español: Este equipo se debe instalar en un sitio con acceso restringido. Un sitio con el acceso restringido es uno seguro y con acceso limitado al personal de servicio que tiene una clave especial u otros medios de seguridad.

Wrist Strap Warning

Because electrostatic discharge (ESD) can damage switch components, you must follow proper procedures to eliminate ESD from your person and the surrounding area before handling switch components.

Français: Parce que les décharges électrostatiques (ESD) peuvent endommager les composants de commutation, vous devez suivre les procédures appropriées pour éliminer ESD de votre personne et la région environnante avant de manipuler les composants de commutation.

Deutsch: Da elektrostatische Entladung (ESD) Komponenten beschädigen können, müssen geeignete Verfahren getroffen werden, diese elektrostatische Entladung bedingt durch Ihre Person oder der Umgebung zu beseitigen.

Español: Debido a las descargas electrostáticas (ESD) puede dañar los componentes del interruptor, debe seguir los procedimientos adecuados para eliminar la ESD de su persona y sus alrededores antes de manipular los componentes del interruptor.

Instrucciones de seguridad en español

Advertencia sobre el levantamiento del chasis

Se requieren dos personas para levantar el chasis. Debido a su peso, la elevación del chasis sin ayuda puede causar daños corporales. También es seguro doblar sus rodillas y guardar su espalda derecho al ayudar a levantar el chasis.

Advertencia de las tapaderas en blanco

Porque regulan la circulación de aire y ayudan a proteger componentes internos del chasis, las tapaderas en blanco deben seguir instaladas en las ranuras vacías del módulo y la fuente de alimentación siempre.

Advertencia en caso de tormenta eléctrica

Para evitar peligro de descargas, no conecte o desconecte ningún cable, ni realice ninguna instalación, mantenimiento o reconfiguración de este producto durante una tormenta eléctrica.

Advertencia de instalación

Solamente el personal bien informado en procedimientos eléctricos y mecánicos básicos debe instalar o mantener este equipo.

Advertencia de radiación láser invisible

Los lasers emiten radiación invisible de la apertura abierta cuando no se conecta ningún cable de fibra óptica. Al quitar los cables no mire fijamente en las aberturas abiertas. Además, instale las cubiertas protectoras de la apertura a las salidas de la fibra sin el cable conectado.

Advertencia de la batería de litio

Hay un peligro de la explosión si la batería del litio en su chasis se substituye incorrectamente. Substituya la batería solamente por el mismo o el equivalente de tipo de batería recomendado por el fabricante. Deseche las baterías usadas según las instrucciones del fabricante. Las instrucciones del fabricante son como sigue: Devuelva el módulo con la batería del litio a Alcatel-Lucent. La batería del litio será substituida en la fábrica de Alcatel-Lucent.

Advertencia sobre la tensión de operación

Para reducir el riesgo del choque eléctrico, mantenga sus manos y dedos fuera de la fuente de alimentación y no toque la placa madre mientras que el interruptor está funcionando.

Advertencia sobre la desconexión de la fuente

Su interruptor esta equipado por fuentes de alimentación múltiples. Para reducir el riesgo de choque eléctrico, asegúrese desconectar todas las conexiones de alimentación antes de mantener o de mover la unidad.

Advertencia sobre una apropiada conexión a tierra

Para evitar peligro de descargas:

- El cable de alimentación debe estar conectado a una toma de alimentación adecuadamente cableada y con toma de tierra.

Cualquier equipo al cual se conecte este producto debe estar también conectado a tomas de alimentación adecuadamente cableadas.

Leer “información importante de seguridad”

La *Guía de “Comenzando a Usar”* que acompaña este equipo contiene información importante de seguridad sobre la cual usted debe saber al trabajar con los componentes de dotación física en este sistema. Usted debe leer esta guía antes de instalar, de usar, o de mantener este equipo.

Advertencia de acceso restringido

Este equipo se debe instalar en una ubicación que restrinja el acceso. Una ubicación con acceso restringido es una donde está seguro y limitado el acceso al personal de servicio que tiene un clave especial, u otros medios de la seguridad.

Advertencia de pulsera antiestática

Debido a que la descarga electrostática (ESD) puede dañar componentes del interruptor, usted debe conectarse a tierra correctamente antes de continuar con la instalación del equipo. Para este propósito, Alcatel-Lucent proporciona una pulsera antiestática y un terminal que pone a tierra situados cerca de la parte superior derecha del chasis. Para que la pulsera antiestática sea eficaz en la eliminación de ESD, las fuentes de alimentación se deben instalar en el chasis y enchufar en las salidas de CA con descarga a tierra.

Clase de seguridad

Cumple con 21CFR 1040.10 y 1040.11 ó sus equivalentes.

Advertencia de fuentes de poder

Las unidades OmniSwitch 6860 pueden estar equipadas con tres cordones para fuente de poder. Para reducir el riesgo de un choque eléctrico, desconecte todos los cordones de fuente de poder antes de dar servicio a la unidad.