



# AIR FORCE

Mid Tower

User Manual



# Product Video Information



**AIRFORCE Product Video**



**AIRFORCE Assembly Video**



**AIRFORCE Installation Video**



# Product Story

## Try True DIY

Admit it, you love building things, especially PCs! So, if you're feeling exceptionally crafty and are up for a new type of PC build, InWin introduces this new chassis set called AIRFORCE! Build, assemble and display with this detailed, 19-piece modular gaming chassis. There's a great feeling from building a PC, but a more satisfying feeling is building your chassis too!

# Specifications

AIR  
FORCE

## InWin AIRFORCE Chassis

<b>Model</b>	AIRFORCE
<b>Model Number</b>	IW-CS-AIRFORCE-WHI, IW-CS-AIRFORCE-BLA
<b>Colors</b>	Justice White, Phantom Black
<b>Case Type</b>	Mid Tower
<b>Materials</b>	Tempered Glass, SECC, ABS
<b>M/B Compatibility</b>	12" x 13" (305 x 330 mm) E-ATX, ATX, Micro-ATX, Mini-ITX
<b>Expansion Slots</b>	8 x PCI-E
<b>Maximum Compatibility</b>	VGA Card Length: 390mm CPU Heatsink Height: 170mm
<b>I/O Ports</b>	1 x USB 3.1 Gen 2 Type-C 2 x USB 3.0 HD Audio
<b>Internal Drive Bays</b>	4 x 2.5" 2 x 3.5"
<b>Thermal Solution Compatibility</b>	Air Cooling Fans: Front: 3 x 120mm Top: 3 x 120mm Rear: 1 x 120mm (4 InWin AL120 Fans Included)  Water Cooling Radiator: Front: 1 x 360mm Top: 1 x 360mm
<small>* Number of fans pre-installed may vary based on different regions.</small>	
<b>Power Supply Compatibility</b>	PSII: ATX12V- Length up to 180mm
<b>Product Dimensions (H x W x D)</b>	528 x 270 x 537mm 20.7 x 10.6 x 21.1"
<b>Package Dimensions (H x W x D)</b>	240 x 590 x 550mm 9.4 x 23.2 x 21.6"
<b>Net Weight</b>	6.9 kg / 15.2 lbs.
<b>Gross Weight</b>	11.2 kg / 24.7 lbs.

\* InWin's products comply with RoHS regulations.

\* Specifications may vary based on different regions.

# Specifications

## InWin Luna AL120 Fans

<b>Model</b>	Luna AL120	
<b>Quantity Included</b>	Single Pack	Triple Pack
<b>Model Number</b>	IW-FN-AL120-1PK	IW-FN-AL120-3PK
<b>Colors</b>	Black	
<b>Fan Size</b>	120 x 120 x 25mm	
<b>Materials</b>	PC, PBT	
<b>Rated Voltage</b>	DC 12V	
<b>Rated Power</b>	3.96W	
<b>Rated Current</b>	0.33A	
<b>ADD RGB Rated Voltage</b>	DC 5V	
<b>ADD RGB Rated Power</b>	1.5W	
<b>ADD RGB Rated Current</b>	0.3A	
<b>Speed Mode</b>	PWM 400-1800 +/-10% RPM	
<b>Air Flow</b>	82.96 CFM	
<b>Air Pressure</b>	2.31mm/H2O	
<b>LED</b>	Addressable RGB	
<b>Connector (Fan to Fan)</b>	Non-Modular Cables	
<b>Connector to M/B</b>	4-Pin (PWM, 12V), 3-Pin (ARGB, 5V)	
<b>Noise Level</b>	25 dB(A) (Normal)	
<b>Bearing Type</b>	Long Lifespan Sleeve Bearing	
<b>Net Weight</b>	133g	399g
<b>Gross Weight</b>	169g	484g
<b>Package Dimensions (L x W x H)</b>	185 x 125 x 30mm 7.3 x 4.9 x 1.2"	185 x 125 x 82mm 7.3 x 4.9 x 3.2"
<b>Warranty</b>	2 Years	

\* InWin's products comply with RoHS regulation.

\* Specifications may vary based on different regions.



# Package Contents

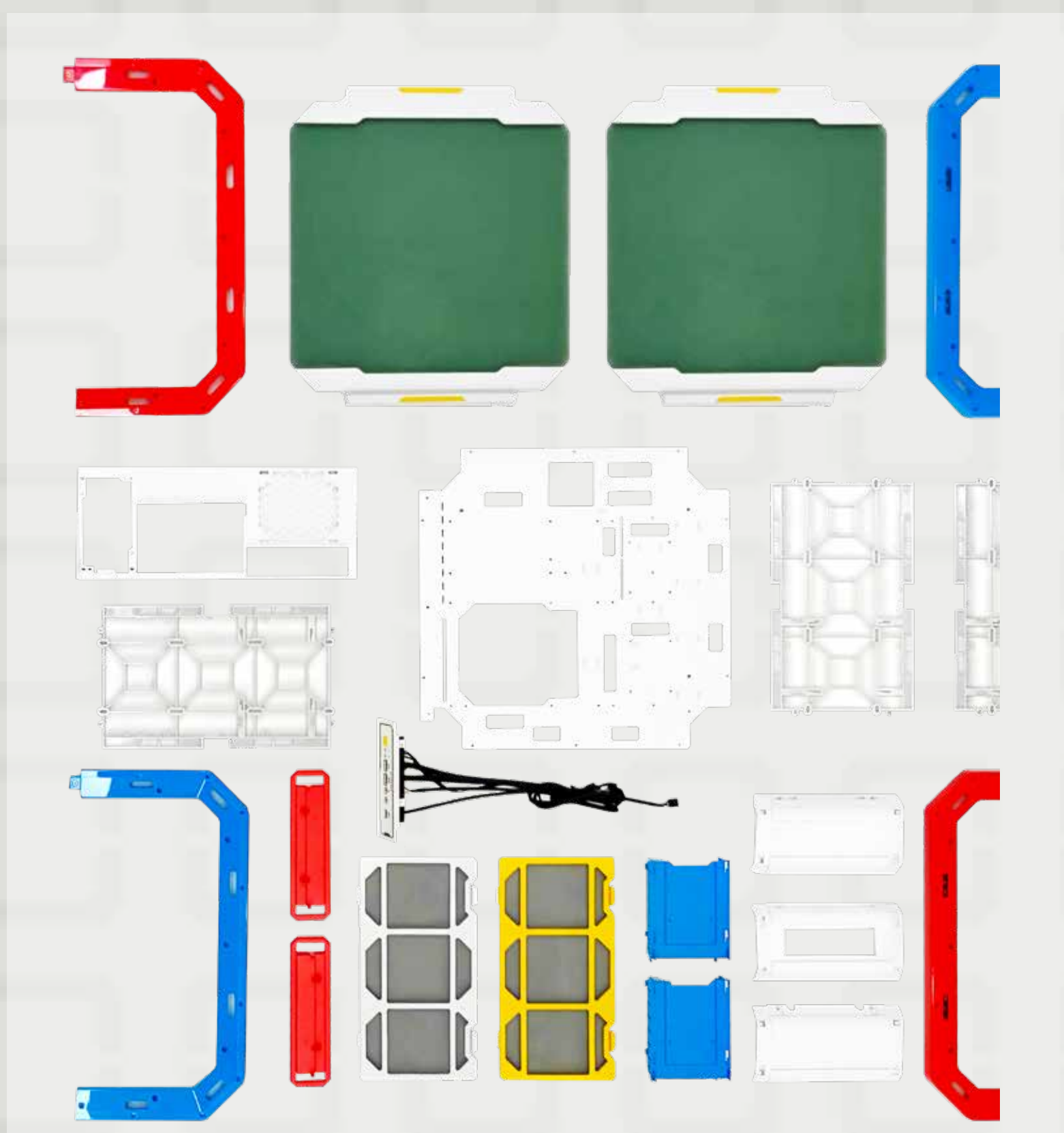

## Accessories Bag

a. S-1 Screws



x 50

b. S-2 Screws



x 5

c. Hexagon Head Screws



x 26

d. Motherboard Stand-offs



x 15

e. Motherboard Stand-off Socket



x 1

f. 2.5" HDD Screws



x 16

g. 3.5" HDD Screws



x 8

h. Cable Ties

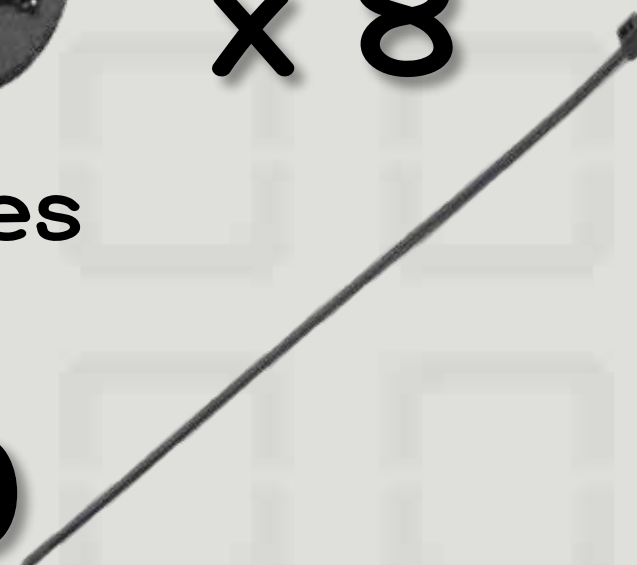

x 10

i. Graphic Cards Holder



x 1

j. PCI-E Slot Brackets



x 8

# Case Structure

**③ Tempered Glass Side Panels**

**② Anti-Dust Filters**

**① I/O Panel**



**② Anti-Dust Filters**

**④ Shock-Proof Stands**

# Case Structure

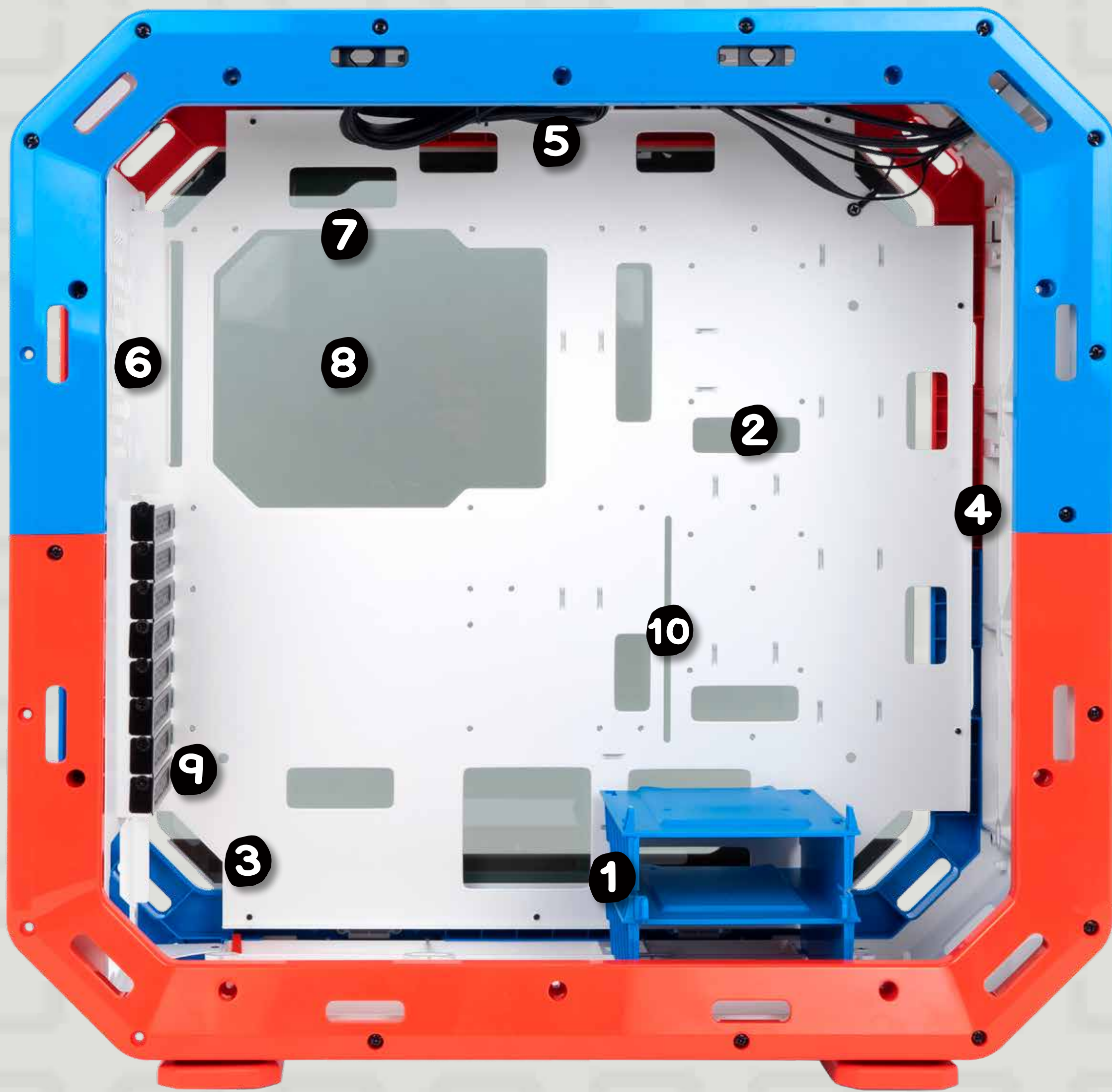

<b>1</b>	2.5"/3.5" HDD Quick Release Drive Bay
<b>2</b>	2.5" SSD Mounting Area
<b>3</b>	Power Supply Mounting Area
<b>4</b>	Front Fans/Radiator Mounting Area
<b>5</b>	Top Fans/Radiator Mounting Area
<b>6</b>	Rear Fan Mounting Area
<b>7</b>	Motherboard Mounting Area
<b>8</b>	CPU Cooler Installation Cut-Out Hole
<b>9</b>	PCI-E Expansion Slots
<b>10</b>	Graphic Cards Holder Mounting Area



# Installation Guide

- \* Please follow the related chapters to assemble.
- \* Please only use original provided accessories to avoid damage to the product.

## 1 Opening the Chassis



## 2 Motherboard Installation

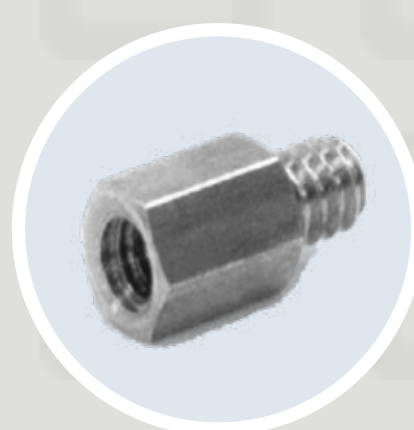
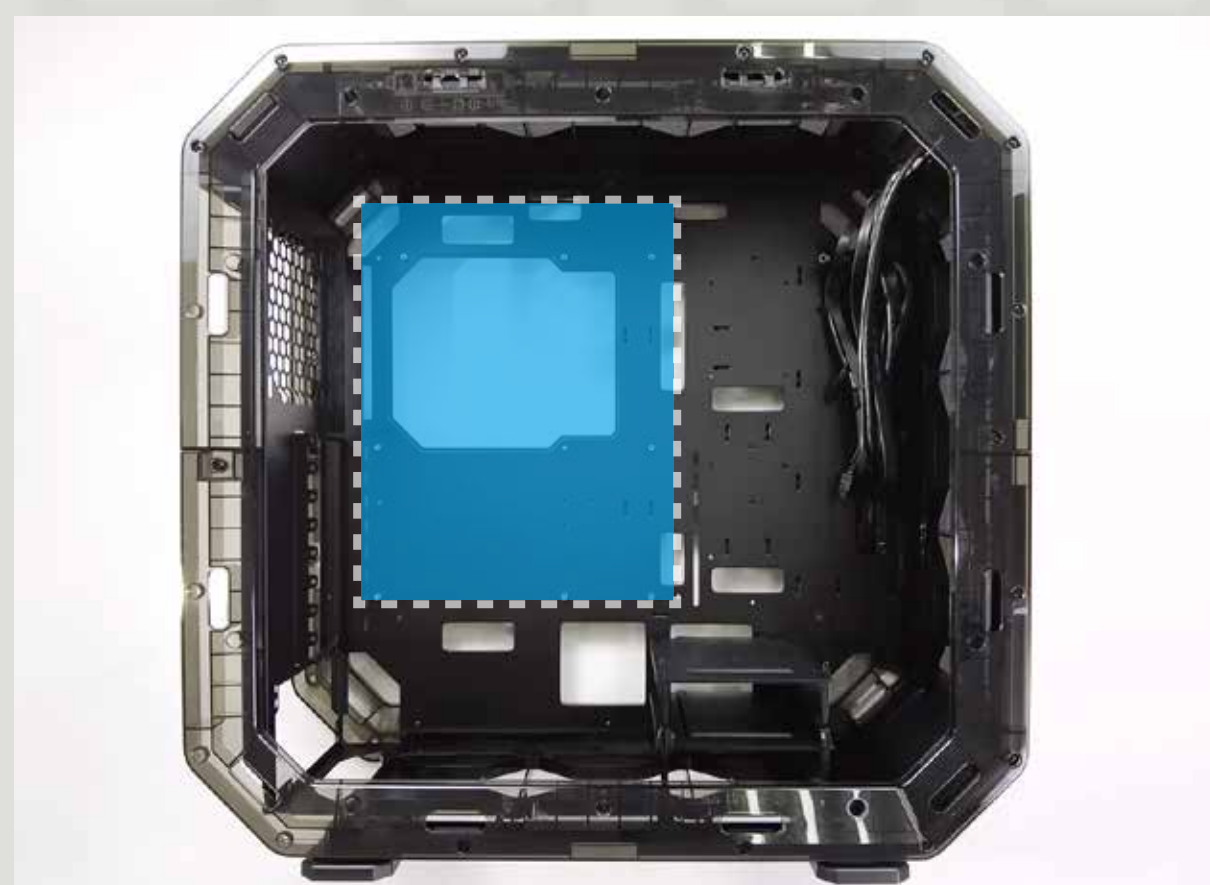

**Parts Required:**  
Motherboard Stand-Offs,  
Motherboard Stand-Off Socket  
Hexagon Head Screws



### 3 Expansion Card Installation



Parts Required: Hexagon Head Screws, Graphics Card Holder, PCI-E Slot Brackets

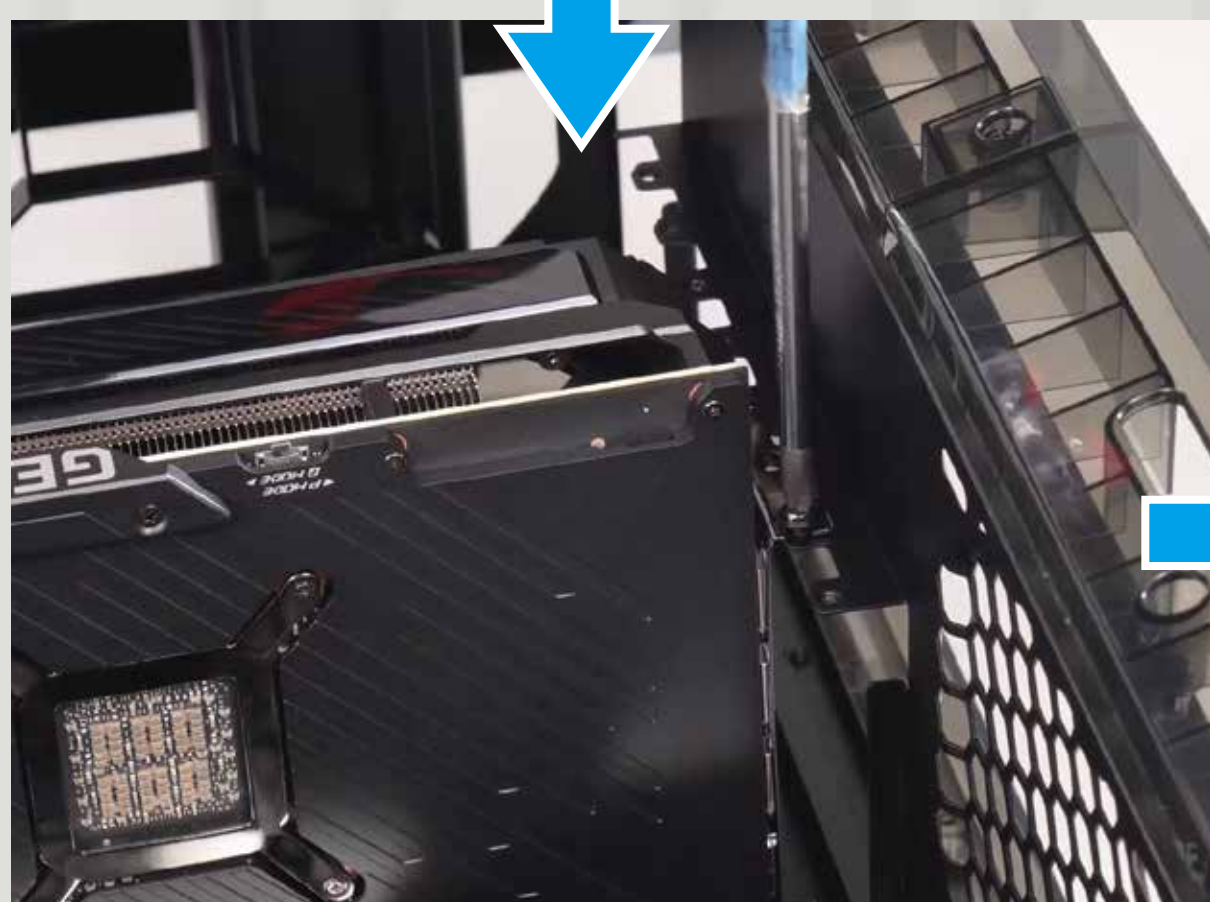

### 4 Connection Cables

#### I/O Wires

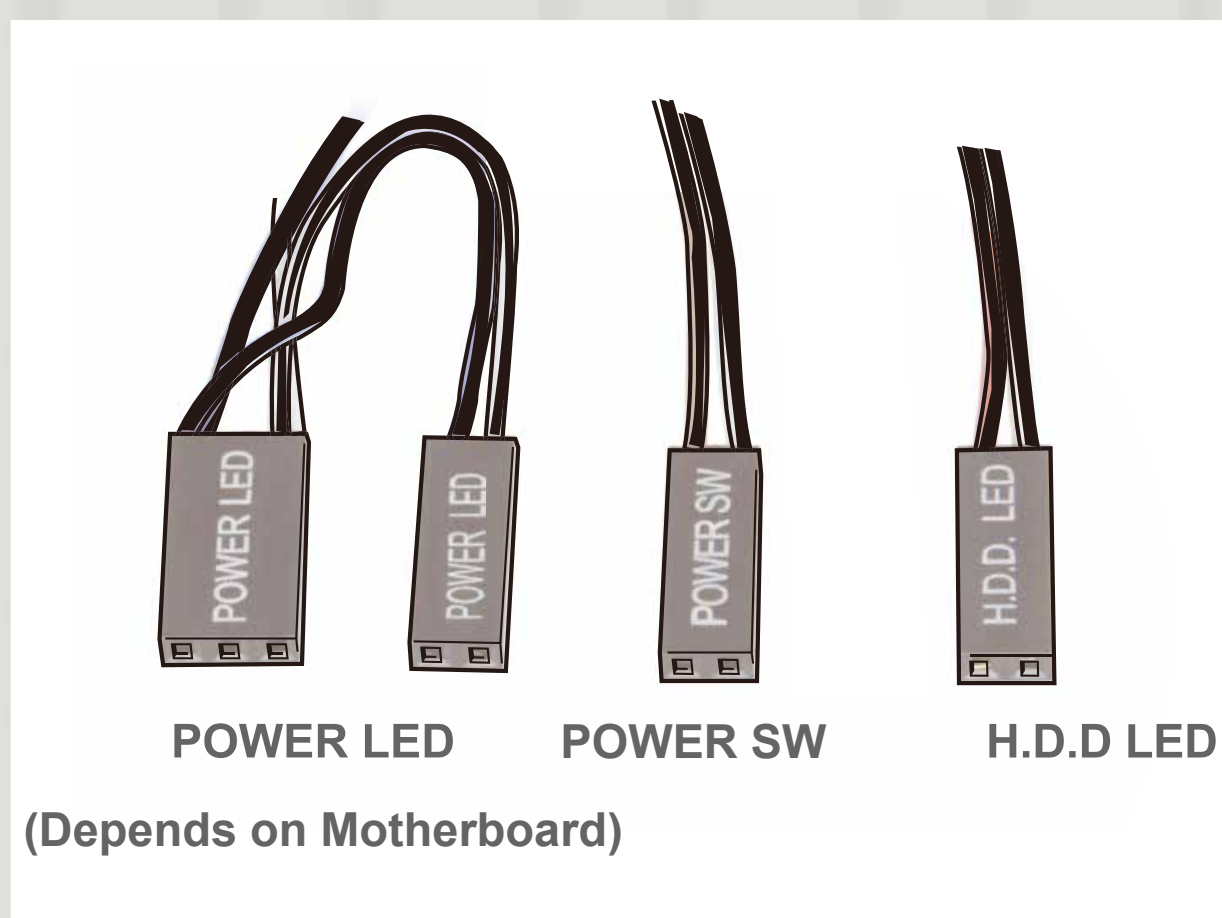

#### HD Audio Header



PORT2_L	BLUE	10	9	BROWN	SENSE2_R
SENSE_SEND	PURPLE	8	7	KEY	
PORT2_R	YELLOW	6	5	WHITE	SNAS1_R
PORT1_R	RED	4	3	ORANGE	PRESENCE#
PORT1_L	GREEN	2	1	BLACK	GND

## USB3.0 Header

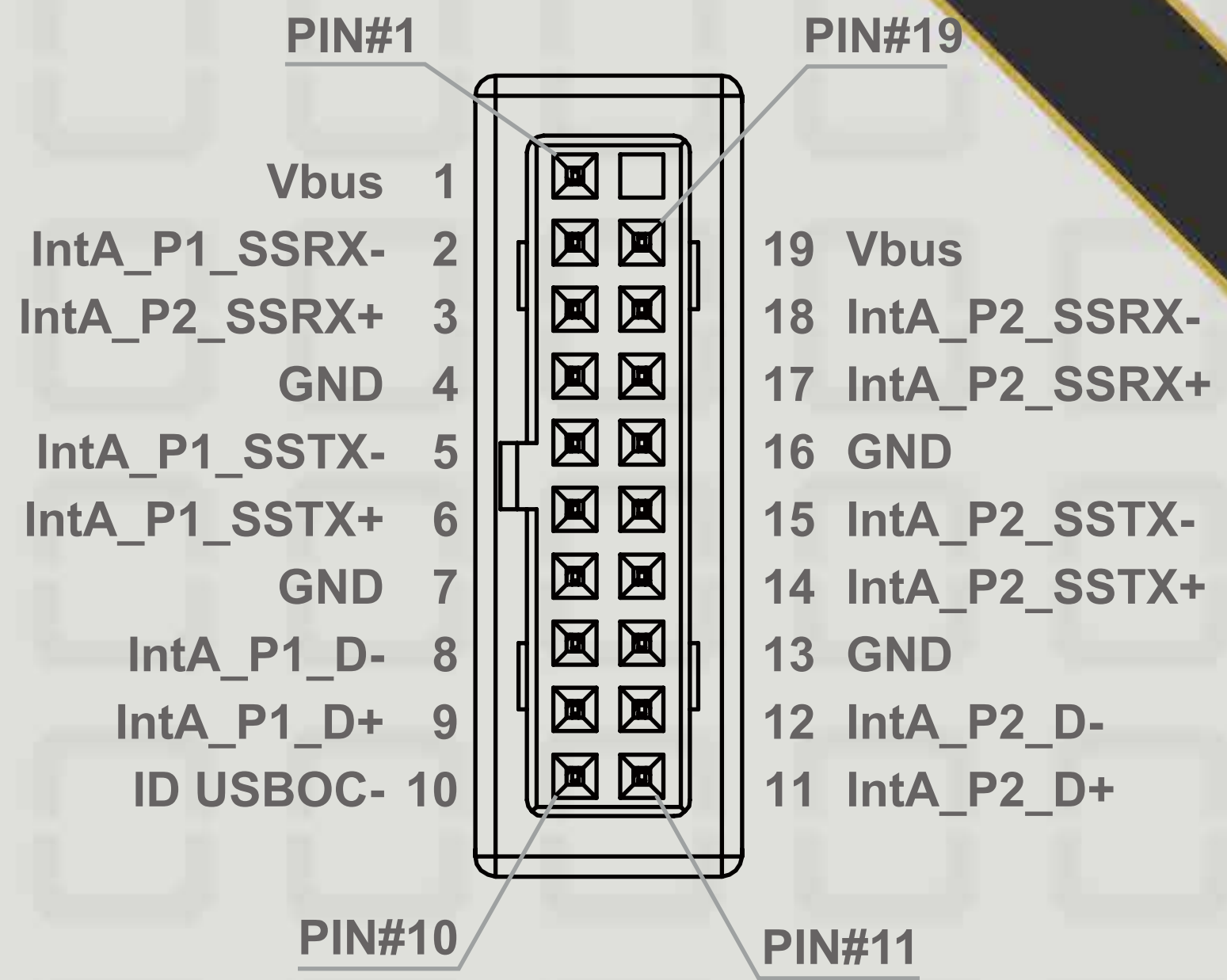
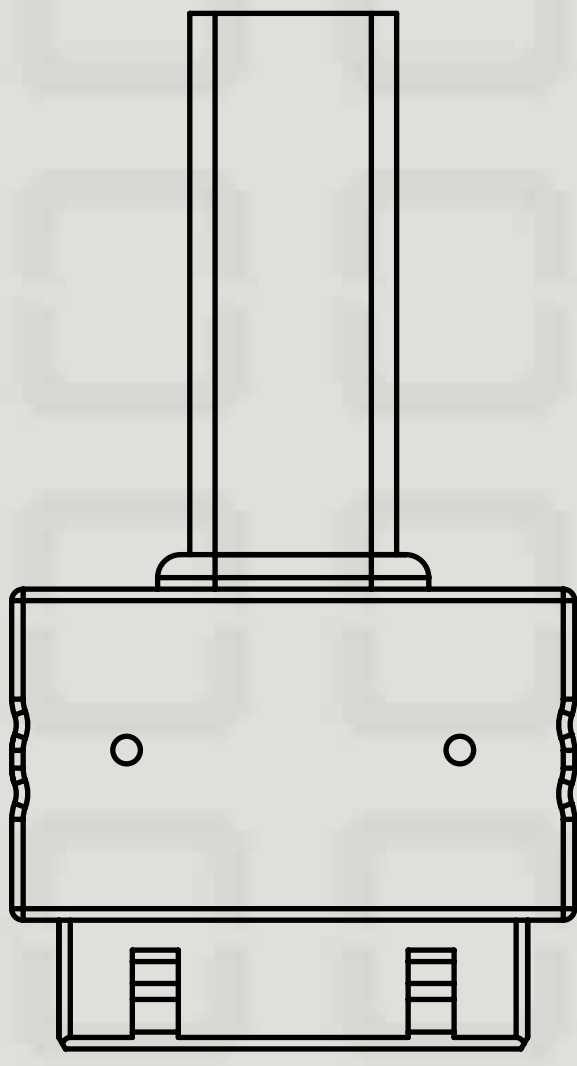

## USB 3.1 Type-C Header

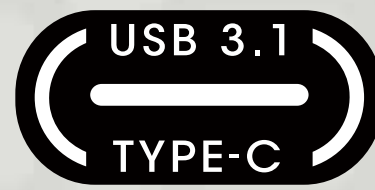
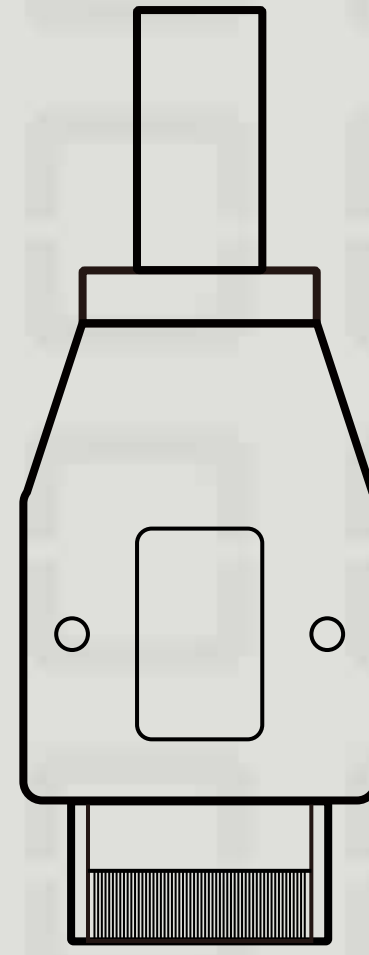

## 5 Fan / Liquid Cooling Radiator Installation



**Parts Required:**  
**Included Luna AL120 Fans**

Fan Installation Instructions: [https://youtu.be/\\_S\\_LLcqe0KI](https://youtu.be/_S_LLcqe0KI)

## 6 2.5"/ 3.5" Drive Bays Installation

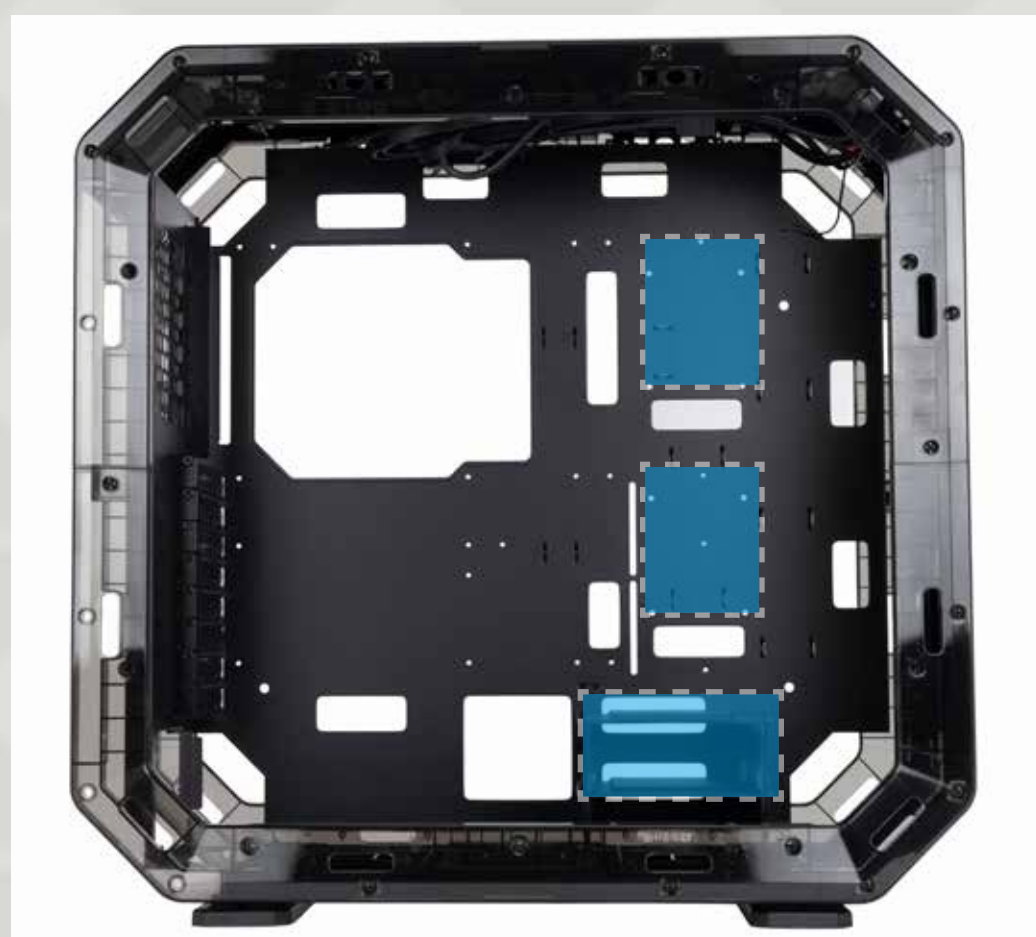

Parts Required: 2.5"/ 3.5" HDD Screws

## 7 Power Supply Installation



Parts Required: Hexagon Head Screws

## 8 Installation Complete



Parts Required: Cable Ties

# Notices and Warranty

## ■ Notices

1. Please follow the user manual for installation guidelines.
2. When installing the computer components, please use antistatic precautions to prevent ESD (electrostatic discharge) damage. Failure to take the necessary precautions may result in injury to the installer and/or damage to the machine. Incorrect installation may burnout the motherboard and other system components.
3. To avoid any damages, please do not use this product for any other purpose than its intended use.
4. Any modifications may damage the product.
5. Please remove all internal devices before shipping or moving. (Including power supply, hard drives, motherboard, CPU, etc.)
6. When storing the case, please keep this product away from high temperatures. Keep away from machines such as heaters that might cause high temperatures.

## ■ Warranty

1. For more detailed warranty information, please visit the InWin retail website at [www.in-win.com](http://www.in-win.com).
2. The actual product is subject to change without prior notice. In Win Development Inc. reserves the right to make final modifications.

**AIR  
FORCE**



**InWin**

**CONTEMPORARY & INNOVATIVE**

**w w w . i n - w i n . c o m**

