



FCC Information and Copyright

This equipment has been tested and found to comply with the limits of a Class B digital device, pursuant to Part 15 of the FCC Rules. These limits are designed to provide reasonable protection against harmful interference in a residential installation. This equipment generates, uses, and can radiate radio frequency energy and, if not installed and used in accordance with the instructions, may cause harmful interference to radio communications. There is no guarantee that interference will not occur in a particular installation.

The vendor makes no representations or warranties with respect to the contents here and specially disclaims any implied warranties of merchantability or fitness for any purpose. Further the vendor reserves the right to revise this publication and to make changes to the contents here without obligation to notify any party beforehand.

Duplication of this publication, in part or in whole, is not allowed without first obtaining the vendor's approval in writing.

The content of this user's manual is subject to be changed without notice and we will not be responsible for any mistakes found in this user's manual. All the brand and product names are trademarks of their respective companies.



Dichiarazione di conformità sintetica
Ai sensi dell'art. 2 comma 3 del D.M. 275 del
30/10/2002

Si dichiara che questo prodotto è conforme
alle normative vigenti e soddisfa i requisiti
essenziali richiesti dalle direttive
2004/108/CE, 2006/95/CE e 1999/05/CE
quando ad esso applicabili

Short Declaration of conformity

We declare this product is complying with the
laws in force and meeting all the essential
requirements as specified by the directives
2004/108/CE, 2006/95/CE and 1999/05/CE
whenever these laws may be applied

Table Of Contents

FCC Information and Copyright	1
Chapter 1: Introduction.....	3
1.1 Before You Start	3
1.2 Package Checklist.....	3
1.3 Specifications.....	4
1.4 Rear Panel Connectors.....	5
1.5 Motherboard Layout	6
Chapter 2: Hardware Installation.....	7
2.1 Install Central Processing Unit (CPU)	7
2.2 Install a Heatsink.....	9
2.3 Connect Cooling Fans	10
2.4 Install System Memory	10
2.5 Expansion Slots.....	12
2.6 Jumper & Switch Setting.....	13
2.7 Headers & Connectors.....	14
Chapter 3: UEFI BIOS & Software.....	18
3.1 UEFI BIOS Setup.....	18
3.2 BIOS Update.....	18
3.3 Software.....	22
Chapter 4: Useful Help	23
4.1 Driver Installation	23
4.2 AMI BIOS Beep Code.....	24
4.3 AMI BIOS post code	24
4.4 Troubleshooting.....	26
APPENDIX I: Specifications in Other Languages	27
Arabic.....	27
German.....	28
Russian.....	29
Spanish	30
Thai	31

Chapter 1: Introduction

1.1 Before You Start

Thank you for choosing our product. Before you start installing the motherboard, please make sure you follow the instructions below:

- Prepare a dry and stable working environment with sufficient lighting.
- Always disconnect the computer from power outlet before operation.
- Before you take the motherboard out from anti-static bag, ground yourself properly by touching any safely grounded appliance, or use grounded wrist strap to remove the static charge.
- Avoid touching the components on motherboard or the rear side of the board unless necessary. Hold the board on the edge, do not try to bend or flex the board.
- Do not leave any unfastened small parts inside the case after installation. Loose parts will cause short circuits which may damage the equipment.
- Keep the computer from dangerous area, such as heat source, humid air and water.
- The operating temperatures of the computer should be 0 to 45 degrees Celsius.
- To avoid injury, be careful of:
 - Sharp pins on headers and connectors
 - Rough edges and sharp corners on the chassis
 - Damage to wires that could cause a short circuit

1.2 Package Checklist

- Serial ATA Cable x2
- Rear I/O Panel for ATX Case x1
- User's Manual x1
- Fully Setup Driver DVD x1

Note

- » *The package contents may be different due to the sales region or models in which it was sold. For more information about the standard package in your region, please contact your dealer or sales representative.*
-

1.3 Specifications

Specifications	
CPU Support	Socket 1151 for 8th Intel® Core i7 / i5 / i3 / Pentium / Celeron processor * 8th Generation Intel® Core™ Processor Family only support 300-Series. * Please refer to www.biostar.com.tw for CPU support list.
Chipset	Intel® B360
Memory	Supports Dual Channel DDR4 1866/ 2133/ 2400/ 2666 2x DDR4 DIMM Memory Slot, Max. Supports up to 32 GB Memory Each DIMM supports non-ECC 4/ 8/ 16GB DDR4 module * Please refer to www.biostar.com.tw for Memory support list.
Storage	4x SATA III Connector (6Gb/s) 1x M.2 (M Key) Socket: Supports M.2 Type 2242/ 2260/ 2280 SSD module Support SATA III (6Gb/s) SSD
LAN	Realtek RTL8111E/ RTL8111F/ RTL8111NH (Optional) 10/ 100/ 1000 Mb/s auto negotiation, Half / Full duplex capability * The motherboard network chip depends on the motherboard purchased by the user.
Audio Codec	ALC887 7.1 Channels, High Definition Audio
USB	6x USB 3.1(Gen1) port (4 on rear I/Os and 2 via internal header) 6x USB 2.0 port (2 on rear I/Os and 4 via internal header)
Expansion Slots	11x PCIe 3.0 x1 Slot 1x PCIe 3.0 x16 Slot * Maximum VGA cards mining support are depending on VGA Driver or mining software.
Rear I/Os	1x PS/2 Mouse 1x PS/2 Keyboard 1x VGA Port 1x HDMI Port 1x LAN port 2x USB 2.0 Port 4x USB 3.1(Gen1) Port 3x Audio Jack
Internal I/Os	4x SATA III Connector (6Gb/s) 2x USB 2.0 Header (each header supports 2 USB 2.0 ports) 1x USB 3.1(Gen1) Header (each header supports 2 USB 3.1(Gen1) ports) 1x 8-Pin Power Connector 2x 24-Pin Power Connector 2 x 6-Pin PCIe Power Connector 1x CPU Fan Connector 2x System Fan Connector 1x Front Panel Header 1x Front Audio Header 1x COM Serial Header 1x Clear CMOS Header
Form Factor	ATX Form Factor, 295mm x 210mm
OS Support	Windows 10(64bit) * Biostar reserves the right to add or remove support for any OS with or without notice.

1.4 Rear Panel Connectors

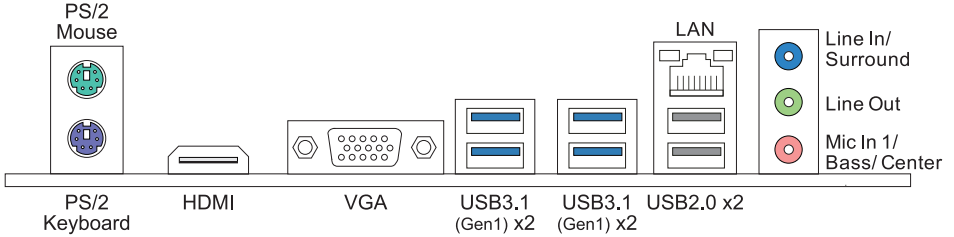

Note

- » VGA / HDMI port only works with an Intel® integrated Graphics Processor.
- » Maximum resolution
VGA: 1920 x 1200 @60Hz
HDMI: 4096 x 2160 @24Hz, compliant with HDMI 1.4
- » When using the front HD audio jack and plug in the headset, the rear sound will be automatically Disabled.
- » To configure 7.1-channel audio, you have to use a chassis with HD front panel audio module and enable the multi-channel audio feature through O.S. Audio Utility.
- » The mainboard supports two onboard display outputs at same time and the display output configuration can be selected in Intel graphics driver utility.

The 2/ 4/ 5.1/ 7.1-channel configuration

Audio Port	2-channel	4-channel	5.1 channel	7.1 channel
Blue (Rear Panel)	Line In	Line In	Line In	Side Speaker Out
Green (Rear Panel)	Line Out	Front Speaker Out	Front Speaker Out	Front Speaker Out
Pink (Rear Panel)	Mic In	Mic In	Center/Subwoofer Out	Center/Subwoofer Out
Green (Front Panel)	Headphone	Rear Speaker Out	Rear Speaker Out	Rear Speaker Out

1.5 Motherboard Layout

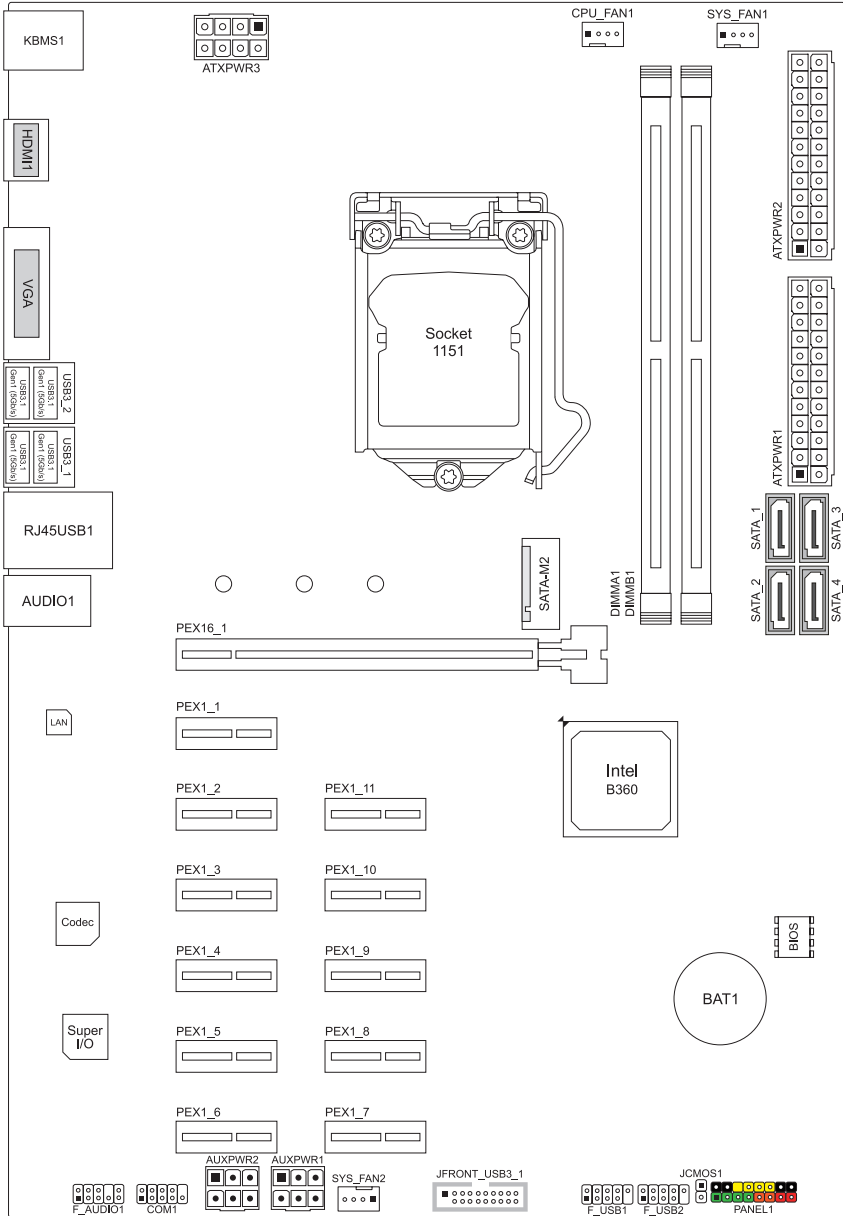

Note

» ■ represents the 1st pin.

Chapter 2: Hardware Installation

2.1 Install Central Processing Unit (CPU)

Step 1: Locate the CPU socket on the motherboard

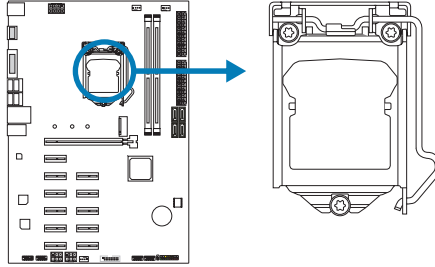

Note

- » Remove pin cap before installation, and make good preservation for future use. When the CPU is removed, cover the pin cap on the empty socket to ensure pin legs won't be damaged.
- » The motherboard might equip with two different types of pin cap. Please refer below instruction to remove the pin cap.

Step 2: Pull the socket locking lever out from the socket and then raise the lever up.

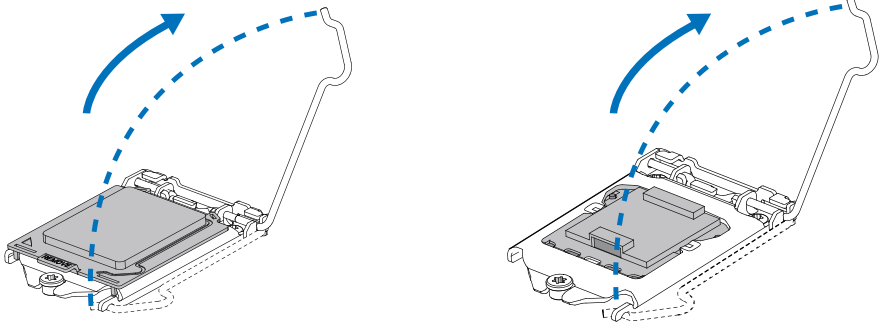

Step 3: Remove the Pin Cap.

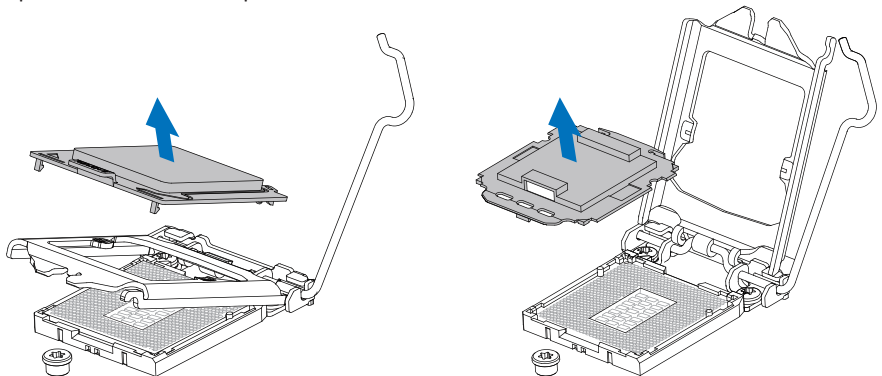

Step 4: Hold processor with your thumb and index fingers, oriented as shown. Align the notches with the socket. Lower the processor straight down without tilting or sliding the processor in the socket.

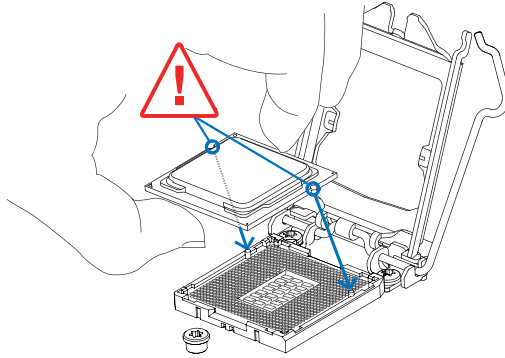

Step 5: Hold the CPU down firmly, and then lower the lever to locked position to complete the installation.

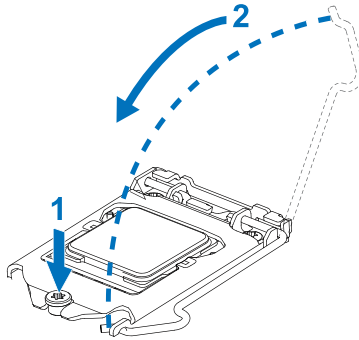

Note

- » Ensure that you install the correct CPU designed for LGA1151 socket.
 - » The CPU fits only in one correct orientation. Do not force the CPU into the socket to prevent damaging the CPU.
-

2.2 Install a Heatsink

Step 1: Place the CPU fan assembly on top of the installed CPU and make sure that the four fasteners match the motherboard holes. Orient the assembly and make the fan cable is closest to the CPU fan connector.

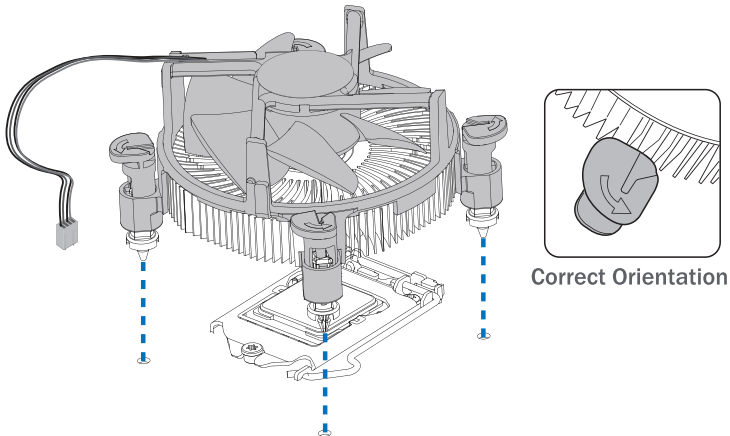

Step 2: Press down two fasteners at one time in a diagonal sequence to secure the CPU fan assembly in place. As each fastener locks into position a click should be heard.

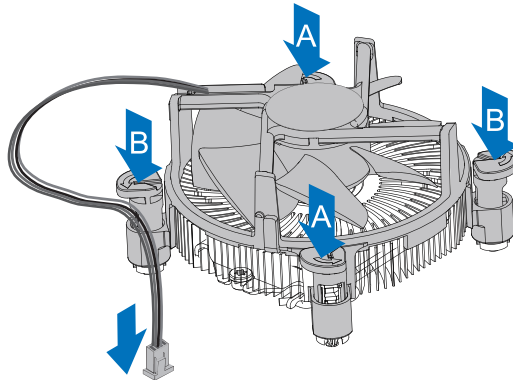

Note

- » Apply the thermal interface material on the CPU before heatsink installation, if necessary.
- » Do not forget to connect the CPU fan connector.
- » For proper installation, please kindly refer to the installation manual of your CPU heatsink.

2.3 Connect Cooling Fans

These fan headers support cooling-fans built in the computer. The fan cable and connector may be different according to the fan manufacturer.

CPU_FAN1: CPU Fan Header

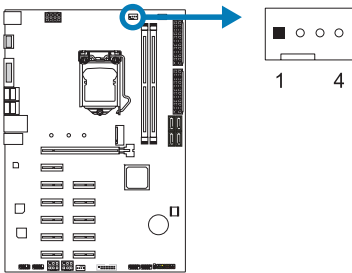

Pin	Assignment
1	Ground
2	+12V
3	FAN RPM rate sense
4	Smart Fan Control (By Fan)

SYS_FAN1/ SYS_FAN2: System Fan Header

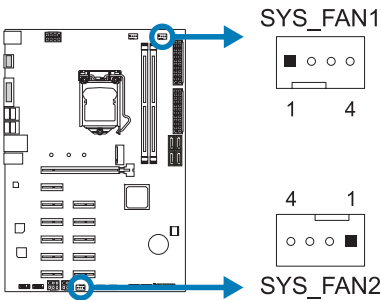

Pin	Assignment
1	Ground
2	+12V
3	FAN RPM rate sense
4	Smart Fan Control (By Fan)

Note

» CPU_FAN1, SYS_FAN1 & SYS_FAN2 support 4-pin and 3-pin head connectors. When connecting with wires onto connectors, please note that the red wire is the positive and should be connected to pin#2, and the black wire is Ground and should be connected to pin#1(GND).

2.4 Install System Memory

DDR4 Modules

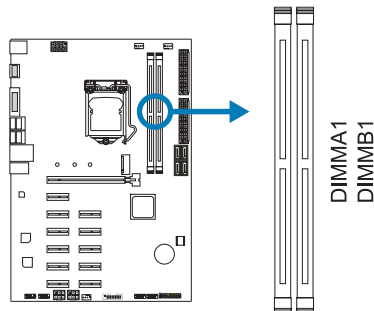

Step 1: Unlock a DIMM slot by pressing the retaining clips outward. Align a DIMM on the slot such that the notch on the DIMM matches the break on the slot.

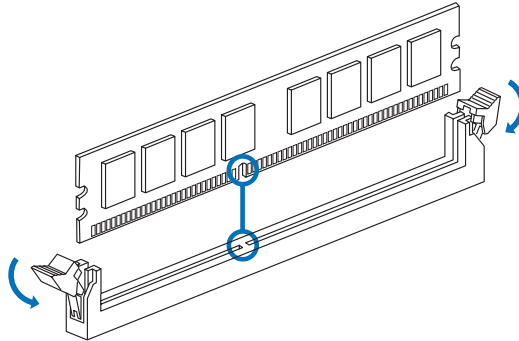

Step 2: Insert the DIMM vertically and firmly into the slot until the retaining clips snap back in place and the DIMM is properly seated.

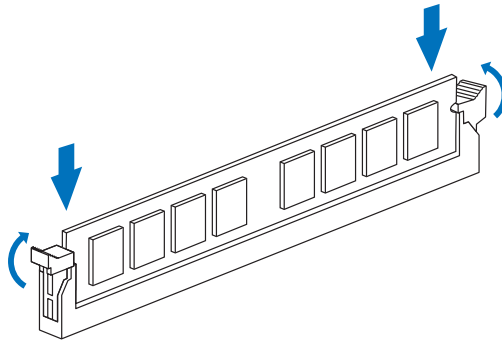

Note

» If the DIMM does not go in smoothly, do not force it. Pull it all the way out and try again.

Memory Capacity

DIMM Socket Location	DDR4 Module	Total Memory Size
DIMMA1	4GB/8GB/16GB	Max is 32GB.
DIMMB1	4GB/8GB/16GB	

Dual Channel Memory Installation

Please refer to the following requirements to activate Dual Channel function:
Install memory module of the same density in pairs, shown in the table.

Dual Channel Status	DIMMA1	DIMMB1
Disabled	O	X
Disabled	X	O
Enabled	O	O

(O means memory installed, X means memory not installed.)

Note

» When installing more than one memory module, we recommend to use the same brand and capacity memory on this motherboard.

2.5 Expansion Slots

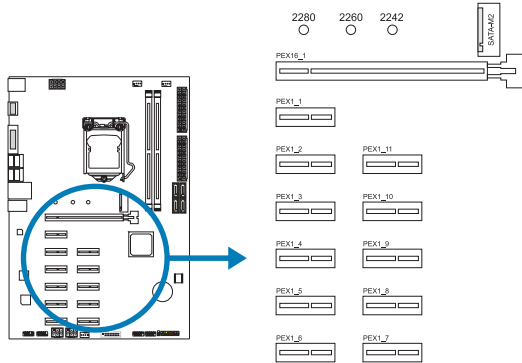

PEX16_1: PCI-Express Gen3 x16 Slot

- PCI-Express 3.0 compliant.
- Theoretical maximum bandwidth using two slots simultaneously is 16GB/s for each slot, a total of 32GB/s.

PEX1_1/ PEX1_2/ PEX1_3/ PEX1_4/ PEX1_5/ PEX1_6/ PEX1_7/ PEX1_8/ PEX1_9/ PEX1_10/ PEX1_11: PCI-Express Gen3 x1 Slots

- PCI-Express 3.0 compliant.
- Data transfer bandwidth up to 1GB/s per direction; 2GB/s in total

SATA-M2: M.2 (M Key) Slot

- The M.2 slot supports M.2 Type 2242/2260/2280 SSD module. When installing M.2 SSD module, please place the screw and hex pillar to correct position.
- Support M.2 SATA III (6.0 Gb/s) module.

Note

» Maximum VGA cards mining support are depending on VGA Driver or mining software.

Install an Expansion Card

You can install your expansion card by following steps:

- Read the related expansion card's instruction document before install the expansion card into the computer.
- Remove your computer's chassis cover, screws and slot bracket from the computer.
- Place a card in the expansion slot and press down on the card until it is completely seated in the slot.
- Secure the card's metal bracket to the chassis back panel with a screw.
- Replace your computer's chassis cover.
- Power on the computer, if necessary, change BIOS settings for the expansion card.
- Install related driver for the expansion card.

2.6 Jumper & Switch Setting

The illustration shows how to set up jumpers. When the jumper cap is placed on pins, the jumper is “close”, if not, that means the jumper is “open”.

Pin opened



Pin closed



Pin 1-2 closed



JCMOS1: Clear CMOS Jumper

The jumper allows users to restore the BIOS safe setting and the CMOS data. Please carefully follow the procedures to avoid damaging the motherboard.

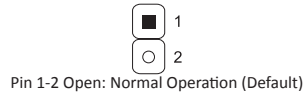
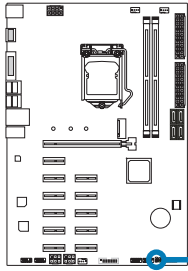

Clear CMOS Procedures:

1. Remove AC power line.
2. Set the jumper to “Pin 1-2 short”, you can use a metal object like a screwdriver to touch the two pins.
3. Wait for five seconds.
4. After clearing the CMOS values, be sure the jumper is “Pin 1-2 open”.
5. Power on the AC.
6. Load Optimal Defaults and save settings in CMOS.

2.7 Headers & Connectors

ATXPWR1/ ATXPWR2: ATX Power Source Connector

For better compatibility, we recommend to use a standard ATX 24-pin power supply for this connector. Make sure to find the correct orientation before plugging the connector.

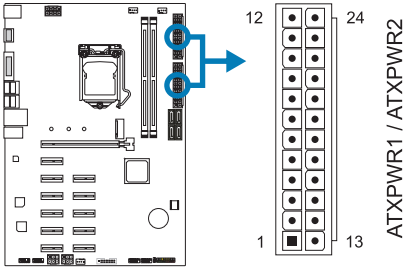

Pin	Assignment	Pin	Assignment
13	+3.3V	1	+3.3V
14	-12V	2	+3.3V
15	Ground	3	Ground
16	PS_ON	4	+5V
17	Ground	5	Ground
18	Ground	6	+5V
19	Ground	7	Ground
20	NC	8	PW_OK
21	+5V	9	Standby Voltage+5V
22	+5V	10	+12V
23	+5V	11	+12V
24	Ground	12	+3.3V

ATXPWR3: ATX Power Source Connector

The connector provides +12V to the CPU power circuit. If the CPU power plug is 4-pin, please plug it into Pin 1-2-5-6 of ATXPWR3.

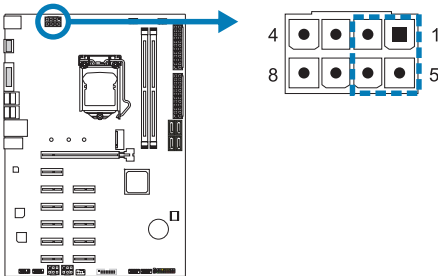

Pin	Assignment
1	+12V
2	+12V
3	+12V
4	+12V
5	Ground
6	Ground
7	Ground
8	Ground

Note

- » Before you power on the system, please make sure that both ATXPWR1/ ATXPWR2 and ATXPWR3 connectors have been plugged-in.
- » When there is only one power supply, the 24-pins ATX power connector must be connected to ATXPWR1, otherwise it will not boot.
- » When there are two power supply, please install the first power supply and connect the 24-pins ATX power connector to ATXPWR1 and the 8-pins ATX power connector to ATXPWR3. After installing the second power supply, the 24-pins ATX power connector is connected to ATXPWR2. If it is installed incorrectly, the motherboard will be damaged.
- » Insufficient power supplied to the system may result in instability or the peripherals not functioning properly. Use of a PSU with a higher power output is recommended when configuring a system with more power-consuming devices.

Install Two Power Supply Rule:

You can install your two power supply by following steps:

1. The 24-pins ATX power connector of power supply1 is connected to ATXPWR1.
2. The 8-pins or 4-pins ATX power connector of power supply1 is connected to ATXPWR3.
3. The 24-pins ATX power connector of power supply2 is connected to ATXPWR2.

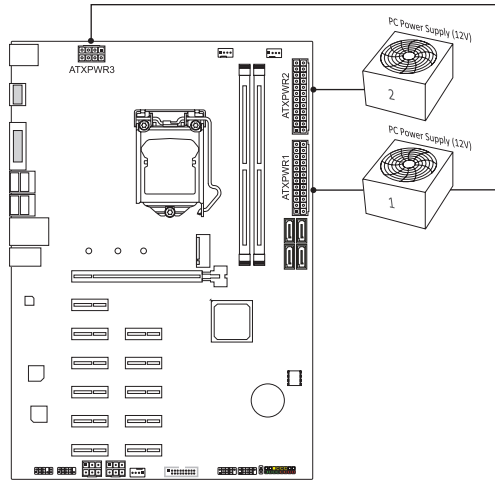

Note

» Ensure proper pin connecting to your ATX power connector, wrong connection may damage your motherboard.

AUXPWR1/ AUXPWR2: PCIe Power Source Connector

The connector provides +12V to the PCIe power circuit.

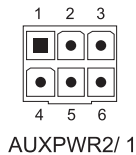
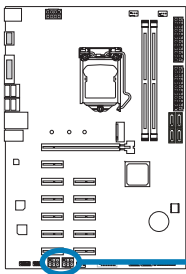

Pin	Assignment
1	+12V_Output
2	+12V_Output
3	+12V_Output
4	Ground
5	Ground
6	Ground

PANEL1: Front Panel Header

This 16-pin header includes Power-on, Reset, HDD LED, Power LED, and speaker connection.

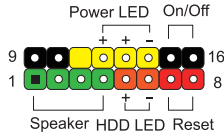
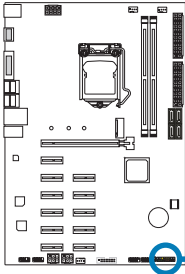

Pin	Assignment	Function	Pin	Assignment	Function
1	+5V	Speaker Connector	9	N/A	N/A
2	N/A		10	N/A	
3	N/A		11	N/A	
4	Speaker		12	Power LED (+)	Power LED
5	HDD LED (+)	13	Power LED (+)		
6	HDD LED (-)	Reset	14	Power LED (-)	Power-on button
7	Ground	button	15	Power button	
8	Reset control		16	Ground	

SATA_1/ SATA_2/ SATA_3/ SATA_4: Serial ATA Connectors

These connectors connect to SATA hard disk drives via SATA cables.

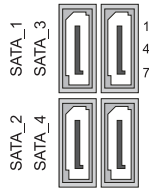
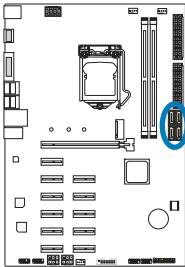

Pin	Assignment
1	Ground
2	TX+
3	TX-
4	Ground
5	RX-
6	RX+
7	Ground

JFRONT_USB3_1: Header for USB 3.1 (Gen1) Ports at Front Panel

This header allows user to add additional USB ports on the PC front panel, and also can be connected with a wide range of external peripherals.

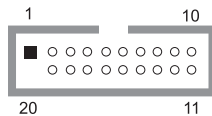
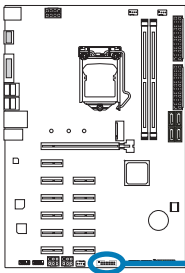

Pin	Assignment	Pin	Assignment
1	VBUS0	11	D2+
2	SSRX1-	12	D2-
3	SSRX1+	13	Ground
4	Ground	14	SSTX2+
5	SSTX1-	15	SSTX2-
6	SSTX1+	16	Ground
7	Ground	17	SSRX2+
8	D1-	18	SSRX2-
9	D1+	19	VBUS1
10	ID	20	Key

F_USB1/ F_USB2: Header for USB 2.0 Ports at Front Panel

This header allows user to add additional USB ports on the PC front panel, and also can be connected with a wide range of external peripherals.

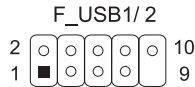
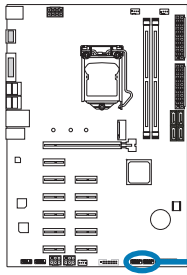

Pin	Assignment
1	+5V (fused)
2	+5V (fused)
3	USB-
4	USB-
5	USB+
6	USB+
7	Ground
8	Ground
9	Key
10	NC

F_AUDIO1: Front Panel Audio Header

This header allows user to connect the chassis-mount front panel audio I/O which supports HD and AC'97 audio standards.

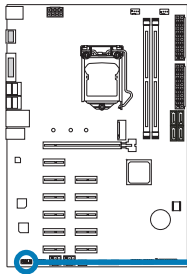

HD Audio		AC'97	
Pin	Assignment	Pin	Assignment
1	Mic Left in	1	Mic In
2	Ground	2	Ground
3	Mic Right in	3	Mic Power
4	GPIO	4	Audio Power
5	Right line in	5	RT Line Out
6	Jack Sense	6	RT Line Out
7	Front Sense	7	Reserved
8	Key	8	Key
9	Left line in	9	LFT Line Out
10	Jack Sense	10	LFT Line Out

Note

- » It is recommended that you connect a high-definition front panel audio module to this connector to avail of the motherboard's high definition audio capability.
- » Please try to disable the "Front Panel Jack Detection" if you want to use an AC'97 front audio output cable. The function can be found via O.S. Audio Utility.

COM1: Serial Port Header

The motherboard has a serial port header for connecting RS-232 Port.

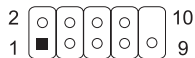
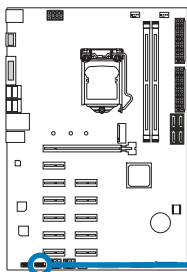

Pin	Assignment
1	Carrier detect
2	Received data
3	Transmitted data
4	Data terminal ready
5	Signal ground
6	Data set ready
7	Request to send
8	Clear to send
9	Ring indicator
10	Key

Chapter 3: UEFI BIOS & Software

3.1 UEFI BIOS Setup

- The BIOS Setup program can be used to view and change the BIOS settings for the computer. The BIOS Setup program is accessed by pressing the key after the Power-On Self-Test (POST) memory test begins and before the operating system boot begins.
- For further information of setting up the UEFI BIOS, please refer to the UEFI BIOS Manual on our website.

3.2 BIOS Update

The BIOS can be updated using either of the following utilities:

- **BIOSTAR BIOS-FLASHER:** Using this utility, the BIOS can be updated from a file on a hard disk, a USB drive (a flash drive or a USB hard drive), or a CD-ROM.
- **BIOSTAR BIOS Update Utility:** It enables automated updating while in the Windows environment. Using this utility, the BIOS can be updated from a file on a hard disk, a USB drive (a flash drive or a USB hard drive), or a CD-ROM, or from the file location on the Web.

BIOSTAR BIOS-FLASHER

Note

- » This utility only allows storage device with FAT32/16 format and single partition.
- » Shutting down or resetting the system while updating the BIOS will lead to system boot failure.

Updating BIOS with BIOSTAR BIOS-FLASHER

1. Go to the website to download the latest BIOS file for the motherboard.
2. Then, copy and save the BIOS file into a USB flash (pen) drive. (Only supported FAT/FAT32 format)
3. Insert the USB pen drive that contains the BIOS file to the USB port.
4. Power on or reset the computer and then press <F12> during the POST process.

5. After entering the POST screen, the BIOS-FLASHER utility pops out. Choose <fs0> to search for the BIOS file.



6. Select the proper BIOS file, and a message asking if you are sure to flash the BIOS file. Click “Yes” to start updating BIOS.

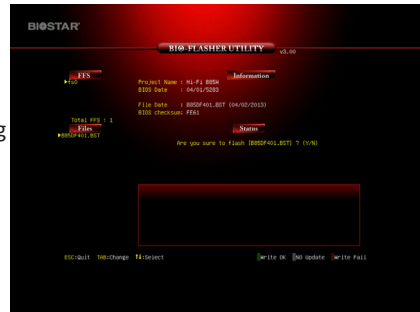

7. A dialog pops out after BIOS flash is completed, asking you to restart the system. Press the <Y> key to restart system.

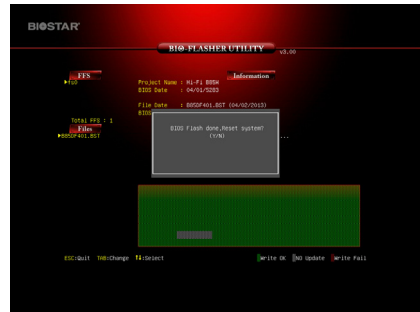

8. While the system boots up and the full screen logo shows up, press key to enter BIOS setup.

After entering the BIOS setup, please go to the <Save & Exit>, using the <Restore Defaults> function to load Optimized Defaults, and select <Save Changes and Reset> to restart the computer. Then the BIOS Update is completed.

BIOS Update Utility (through the Internet)

1. Installing BIOS Update Utility from the DVD Driver.
2. Please make sure the system is connected to the internet before using this function.

3. Launch BIOS Update Utility and click the “Online Update” button on the main screen.



4. An open dialog will show up to request your agreement to start the BIOS update. Click “Yes” to start the online update procedure.

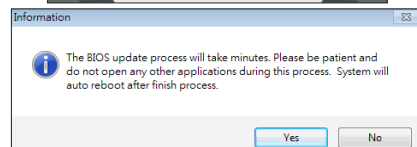

5. If there is a new BIOS version, the utility will ask you to download it. Click “Yes” to proceed.

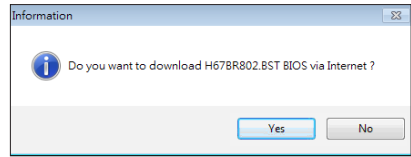

6. After the download is completed, you will be asked to program (update) the BIOS or not. Click “Yes” to proceed.

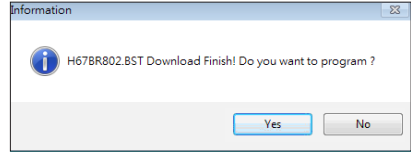

7. After the updating process is finished, you will be asked you to reboot the system. Click “OK” to reboot.

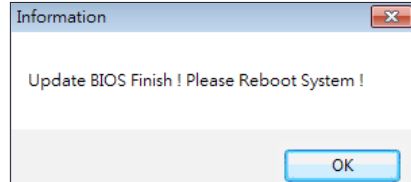

8. While the system boots up and the full screen logo shows up, press key to enter BIOS setup.

After entering the BIOS setup, please go to the <Save & Exit>, using the <Restore Defaults> function to load Optimized Defaults, and select <Save Changes> and <Reset> to restart the computer. Then, the BIOS Update is completed.

BIOS Update Utility (through a BIOS file)

1. Installing BIOS Update Utility from the DVD Driver.
2. Download the proper BIOS from <http://www.biostar.com.tw/>

3. Launch BIOS Update Utility and click the “Update BIOS” button on the main screen.



4. A warning message will show up to request your agreement to start the BIOS update. Click “OK” to start the update procedure.

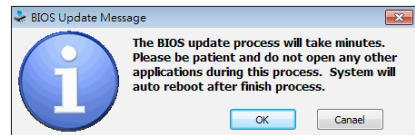

5. Choose the location for your BIOS file in the system. Please select the proper BIOS file, and then click on "Open". It will take several minutes, please be patient.

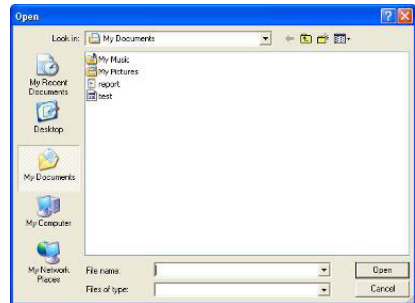

6. After the BIOS Update process is finished, click on "OK" to reboot the system.

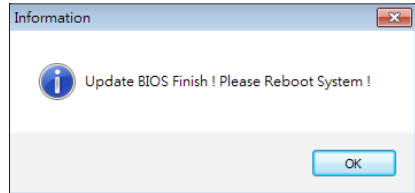

7. While the system boots up and the full screen logo shows up, press key to enter BIOS setup.

After entering the BIOS setup, please go to the <Save & Exit>, using the <Restore Defaults> function to load Optimized Defaults, and select <Save Changes and Reset> to restart the computer. Then, the BIOS Update is completed.

Backup BIOS

Click the Backup BIOS button on the main screen for the backup of BIOS, and select a proper location for your backup BIOS file in the system, and click "Save".

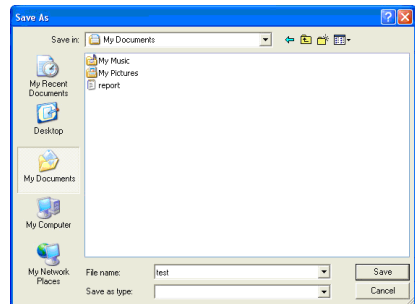

3.3 Software

Installing Software

1. Insert the Setup DVD to the optical drive. The driver installation program would appear if the Auto-run function has been enabled.
2. Select Software Installation, and then click on the respective software title.
3. Follow the on-screen instructions to complete the installation.

Launching Software

After the installation process is completed, you will see the software icon showing on the desktop. Double-click the icon to launch it.

Note

- » All the information and content about following software are subject to be changed without notice. For better performance, the software is being continuously updated.
- » The information and pictures described below are for your reference only. The actual information and settings on board may be slightly different from this manual.

BIOScreen Utility

This utility allows you to personalize your boot logo easily. You can choose BMP as your boot logo so as to customize your computer.



Please follow the step-by-step instructions below to update boot logo:

- Load Image: Choose the picture as the boot logo.
- Transform: Transform the picture for BIOS and preview the result.
- Update Bios: Write the picture to BIOS Memory to complete the update.

Chapter 4: Useful help

4.1 Driver Installation

After you installed your operating system, please insert the Fully Setup Driver DVD into your optical drive and install the driver for better system performance.

You will see the following window after you insert the DVD



The setup guide will auto detect your motherboard and operating system.

A. Driver Installation

To install the driver, please click on the Driver icon. The setup guide will list the compatible driver for your motherboard and operating system. Click on each device driver to launch the installation program.

B. Software Installation

To install the software, please click on the Software icon. The setup guide will list the software available for your system, click on each software title to launch the installation program.

C. Manual

Aside from the paperback manual, we also provide manual in the Driver DVD. Click on the Manual icon to browse for available manual.

► Note

- » *If this window didn't show up after you insert the Driver DVD, please use file browser to locate and execute the file SETUP.EXE under your optical drive.*
- » *You will need Acrobat Reader to open the manual file. Please download the latest version of Acrobat Reader software from <http://get.adobe.com/reader/>*

4.2 AMI BIOS Beep Code

Boot Block Beep Codes

Number of Beeps	Description
Continuing	Memory sizing error or Memory module not found

POST BIOS Beep Codes

Number of Beeps	Description
1	Success booting.
8	Display memory error (system video adapter)

4.3 AMI BIOS post code

Code	Description
10	PEI Core is started
11	Pre-memory CPU initialization is started
15	Pre-memory North Bridge initialization is started
19	Pre-memory South Bridge initialization is started
2B	Memory initialization. Serial Presence Detect (SPD) data reading
2C	Memory initialization. Memory presence detection
2D	Memory initialization. Programming memory timing information
2E	Memory initialization. Configuring memory
2F	Memory initialization (other).
31	Memory Installed
32	CPU post-memory initialization is started
33	CPU post-memory initialization. Cache initialization
34	CPU post-memory initialization. Application Processor(s) (AP) initialization
35	CPU post-memory initialization. Boot Strap Processor (BSP) selection
36	CPU post-memory initialization. System Management Mode (SMM) initialization
37	Post-Memory North Bridge initialization is started
3B	Post-Memory North Bridge initialization (North Bridge module specific)
4F	DXE IPL is started
60	DXE Core is started
F0	Recovery condition triggered by firmware (Auto recovery)
F1	Recovery condition triggered by user (Forced recovery)
F2	Recovery process started
F3	Recovery firmware image is found
F4	Recovery firmware image is loaded
E0	S3 Resume is started (S3 Resume PPI is called by the DXE IPL)
E1	S3 Boot Script execution
E2	Video repost
E3	OS S3 wake vector call
60	DXE Core is started
61	NVRAM initialization
62	Installation of the South Bridge Runtime Services
63	CPU DXE initialization is started
68	PCI host bridge initialization
69	North Bridge DXE initialization is started
6A	North Bridge DXE SMM initialization is started

Code	Description
70	South Bridge DXE initialization is started
71	South Bridge DXE SMM initialization is started
72	South Bridge devices initialization
78	South Bridge DXE Initialization (South Bridge module specific)
79	ACPI module initialization
90	Boot Device Selection (BDS) phase is started
91	Driver connecting is started
92	PCI Bus initialization is started
93	PCI Bus Hot Plug Controller Initialization
94	PCI Bus Enumeration
95	PCI Bus Request Resources
96	PCI Bus Assign Resources
97	Console Output devices connect
98	Console input devices connect
99	Super IO Initialization
9A	USB initialization is started
9B	USB Reset
9C	USB Detect
9D	USB Enable
A0	IDE initialization is started
A1	IDE Reset
A2	IDE Detect
A3	IDE Enable
A4	SCSI initialization is started
A5	SCSI Reset
A6	SCSI Detect
A7	SCSI Enable
A8	Setup Verifying Password
A9	Start of Setup
AB	Setup Input Wait
AD	Ready To Boot event
AE	Legacy Boot event
AF	Exit Boot Services event
B0	Runtime Set Virtual Address MAP Begin
B1	Runtime Set Virtual Address MAP End
B2	Legacy Option ROM Initialization
B3	System Reset
B4	USB hot plug
B5	PCI bus hot plug
B6	Clean-up of NVRAM
B7	Configuration Reset (reset of NVRAM settings)

4.4 Troubleshooting

Probable	Solution
<ol style="list-style-type: none"> 1. There is no power in the system. Power LED does not shine; the fan of the power supply does not work. 2. Indicator light on keyboard does not shine. 	<ol style="list-style-type: none"> 1. Make sure power cable is securely plugged in. 2. Replace cable. 3. Contact technical support.
System is inoperative. Keyboard lights are on, power indicator lights are lit, and hard drives are running.	Using even pressure on both ends of the DIMM, press down firmly until the module snaps into place.
System does not boot from a hard disk drive, but can be booted from optical drive.	<ol style="list-style-type: none"> 1. Check cable running from disk to disk controller board. Make sure both ends are securely plugged in; check the drive type in the standard CMOS setup. 2. Backing up the hard drive is extremely important. All hard disks are capable of breaking down at any time.
System only boots from an optical drive. Hard disks can be read, applications can be used, but system fails to boot from a hard disk.	<ol style="list-style-type: none"> 1. Back up data and applications files. 2. Reformat the hard drive. Re-install applications and data using backup disks.
Screen message shows "Invalid Configuration" or "CMOS Failure."	Review system's equipment. Make sure correct information is in setup.
System cannot boot after user installs a second hard drive.	<ol style="list-style-type: none"> 1. Set master/slave jumpers correctly. 2. Run SETUP program and select correct drive types. Call the drive manufacturers for compatibility with other drives.

CPU Overheated

If the system shutdown automatically after power on system for seconds, that means the CPU protection function has been activated.

When the CPU is over heated, the motherboard will shutdown automatically to avoid a damage of the CPU, and the system may not power on again.

In this case, please double check:

1. The CPU cooler surface is placed evenly with the CPU surface.
2. CPU fan is rotated normally.
3. CPU fan speed is fulfilling with the CPU speed.

After confirmed, please follow steps below to relief the CPU protection function.

1. Remove the power cord from power supply for seconds.
2. Wait for seconds.
3. Plug in the power cord and boot up the system.

Or you can:

1. Clear the CMOS data. (See "Close CMOS Header: JCMOS1" section)
2. Wait for seconds.
3. Power on the system again.

APPENDIX I: Specifications in Other Languages

Arabic

المواصفات	
المأخذ 1151 لمعالج ايه إم دي Intel® Core i7 / i5 / i3 / Pentium / Celeron (الجيل 8) * م عدد ليجلا 8 نم Intel® روك™ ملاءم ليعلمنا 300 ملسلس طقف. * يرجى الرجوع إلى الموقع www.biostar.com.tw لقائمة دعم المعالج CPU.	قاعدة وحدة المعالجة المركزية
Intel® B360	مجموعة الشرائح
م عدد نائف تتحاو DDR4 1866/2133/2400/2666 2x دي. دي. ار. DDR4 فتحات الذاكرة المزودة DIMM، تتحمل كحد أقصى 32 جيجابايت ذاكرة كل فتحة مزدوجة DIMM تتحمل دون ECC 16/8 4 DDR4 دي. دي. ار. * يرجى الرجوع إلى الموقع www.biostar.com.tw لقائمة دعم الذاكرة.	الذاكرة
صلة 4x ساتا SATA III (6Gb/s) x1 فتحة (M Key) لكيرباه قابس : م عدد تتحاو M.2 Type 2242/2260/2280 SSD ي.دع SATA III (6Gb/s) SSD	التخزين
Realtek RTL8111E /RTL8111F /RTL8111HN (اختراري) 10 / 100 / 1000 ميجابايت / الثانية ، تحديد تلقائي ، النصف / القدرة القصوى المزودة * بدمتد محيرش تكيش محوللا ملاءم محوللا ملاءم ايلا اهيرتو مدختسما	شبكة محلية LAN
ALC887 7.1 قنوات عالية الدقة	الترميز الصوتي
منافذ x6 ناقل متسلسل عام USB 3.1 (Gen1) (4 في المداخل والمخارج الخلفية و 2 من خلال الموزع الداخلي) منافذ x6 ناقل متسلسل عام USB 2.0 (2 في المداخل والمخارج الخلفية و 4 من خلال الموزع الداخلي)	ناقل متسلسل عام USB
x11 فتحة منفذ الملحقات الإضافية PCIe 3.0 x 1 x1 فتحة منفذ الملحقات الإضافية PCIe 3.0 x 16 * دطلا يصفلا م عدد تتقاطو اغف نيدعتنا بدمتد ملاءم ملاءم ليعيش اغف وأ نيدعتنا.	فتحات التوسع
x1 PS/2 لوحة المفاتيح للكمبيوتر x1 PS/2 الفأرة فتحة توصيل عدد x1 واجهة مرئية رقمية VGA فتحة توصيل عدد x1 واجهة مرئية رقمية HDMI فتحة لتوصيل عدد x1 الشبكة المحلية LAN فتحة توصيل عدد x2 ناقل متسلسل عام USB 2.0 فتحة توصيل عدد x4 ناقل متسلسل عام USB 3.1 (Gen1) فتحة توصيل عدد x3 جاك للصوت	المداخل والمخارج الخلفية
وصلة 4x ساتا SATA III (6Gb/s) موزع x2 ناقل متسلسل عام USB 2.0 (كل موزع يتحمل فتحتين ناقل متسلسل عام USB 2.0) موزع x1 ناقل متسلسل عام USB 3.1 (Gen1) (كل موزع يتحمل فتحتين ناقل متسلسل عام USB 3.1) وصلة للطاقة x1 8 دبابيس وصلة للطاقة x2 24 دبابيس وصلة للطاقة x2 PCIe 6 دبابيس وصلة x1 مروحة تبريد وحدة المعالجة المركزية وصلة x2 مراوح تبريد المنظومة موزع x1 اللوحة الأمامية موزع x1 الصوت الأمامي موزع x1 فتحة تسلسلية موزع x1 Clear CMOS	المداخل والمخارج الداخلية
عامل الشكل	عامل الشكل
م 210 م x 295 م ، ATX ، ويندوز 10(64bit)	عامل الشكل
* بيوستار BIOSTAR تحتفظ بحق إضافة أو إزالة الدعم لأي نظام تشغيل مع أو بدون انظار.	أنظمة التشغيل المدعومة

German

Spezifikationen	
CPU-Unterstützung	Anschluss-1151 für den 8. Intel® Core i7 / i5 / i3 / Pentium / Celeron Prozessor * 8. Generation Intel® Core™ Prozessor Familie unterstützt nur 300-Serie. * Bitte konsultieren Sie www.biostar.com.tw für CPU-Unterstützungsliste
Chipset	Intel® B360
Festplattenspeicher	Unterstützt zweikanaliges DDR4 1866/ 2133/ 2400/ 2666 2x DDR4 DIMM-SpeicherSlot, Max. Uterstützung bis zu 32 GB-Speicher Jedes DIMM unterstützt nicht-ECC 4/ 8/ 16 GB DDR4-Module * Bitte konsultieren Sie www.biostar.com.tw für Speicherunterstützung Liste.
Arbeitsspeicher	4x SATA III-Verbindung (6Gb/s) 1x M.2 (M Key) Slot: Unterstützt M.2 Typ 2242/ 2260/ 2280 SSD-Modul Unterstützt SATA III (6Gb/s) SSD
LAN	Realtek RTL8111E/RTL8111F/RTL8111HN(Optional) 10/ 100/ 1000 Mb Auto-Negotiation, Halb- / Voll-Duplex-fähig * Der Motherboard-Netzwerk Chip hängt vom vom Benutzer gekauften Motherboard ab.
Audio-Codec	ALC887 7.1 Kanäle, HD-Audio
USB	6x USB 3.1(Gen1)-Port (4 hintere I/Os und 2 via interne Header) 6x USB 2.0-Port (2 hintere I/Os und 4 via interne Header)
Erweiterungsanschlüsse	11x PCIe 3.0 x1-Slot 1x PCIe 3.0 x16-Slot * Maximale VGA-Karten Bergbau-Unterstützung sind abhängig von VGA-Treiber oder Bergbau-Software.
Hintere I/Os	1x PS/2-Maus 1x PS/2-Keyboard 1x VGA-Port 1x HDMI-Port 1x LAN-Port 2x USB 2.0-Port 4x USB 3.1(Gen1)-Port 3x Audio Jack
Interne I/Os	4x SATA III-Verbindung (6Gb/s) 2x USB 2.0-Header (jeder Header unterstützt 2 USB 2.0-Ports) 1x USB 3.1(Gen1)-Header (jeder Header unterstützt 2 USB 3.1(Gen1)-Ports) 1x 8-Pin-Stromverbindung 2x 24-Pin-Stromverbindung 2x 6-Pin-PCIe Stromverbindung 1x CPU-Ventilatorverbindung 2x System-Ventilatorverbindung 1x Header für Frontpanel 1x Header für Frontaudio 1x Header für Seriellen Anschluss 1x Header für klares CMOS
Formfaktor	ATX Formfaktor, 295 mm x 210mm
OS-Unterstützung	Windows 10(64bit) * Biostar reserves the right to add or remove support for any OS with or without notice.

Russian

Спецификации	
Поддержка центрального процессора	Сокет 1151 для 8-го процессоров Intel® Core i7 / i5 / i3 / Pentium / Celeron * Семейство процессоров Intel® Core™ 8-го поколения поддерживает только 300-Series. * Перечень поддержки центрального процессора смотрите на www.biostar.com.tw .
Набор микросхем	Intel® В360
Память	Поддерживает двухканальный DDR4 1866/ 2133/ 2400/ 2666 2 гнезда платы памяти DDR4 DIMM, максимальная память до 32 Гб Каждый модуль DIMM поддерживает модуль не-ECC 4/ 8/ 16 Гб DDR4 * Перечень поддержки памяти смотрите на www.biostar.com.tw .
Накопитель	Соединитель 4x SATA III (6Gb/s) 1 сокет M.2 (M Key): Поддерживает модуль SSD 2242/ 2260/ 2280 типа M.2 Поддерживает SATA III (6Gb/s) SSD
Локальная сеть	Realtek RTL8111E/RTL8111F/RTL8111HN(Необязательный) Автосогласование 10/ 100/ 1000 Мб/с, работает в полно/полудуплексном режиме * Сетевой чип материнской платы зависит от материнской платы, купленной пользователем.
Аудиокодек	ALC887 Каналы 7.1, высококачественное аудио
USB	6 порта USB 3.1(Gen1) (4 сзади ввода-вывода и 2 через внутренние контакты) 6 порта USB 2.0 (2 сзади ввода-вывода и 4 через внутренние контакты)
Гнезда расшир.	11x PCIe 3.0 x1 гнездо 1x PCIe 3.0 x16 гнездо * Поддержка максимальной поддержки VGA-карт зависит от драйвера VGA или программного обеспечения для горнодобывающей промышленности.
Задняя плата ввода-вывода	1 мышь PS/2 1 клавиатура PS/2 1 порт VGA 1 порт HDMI 1 порт локальной сети 2 порта USB 2.0 4 порта USB 3.1(Gen1) 3 гнезд для подключения наушников
Внутр. Плата ввода-вывода	Соединитель 4x SATA III (6Gb/s) 2 контакта USB 2.0 (каждый контакт поддерживает 2 порта USB 2.0) 1 контакт USB 3.1(Gen1) (каждый контакт поддерживает 2 порта USB 3.1(Gen1)) 1 8-выводный разъем питания 2 24-выводный разъем питания 2 6-выводный PCIe разъем питания 1 разъем вентилятора ЦП 2 разъема вентилятора системы 1 контакт передней панели 1 контакт передней аудиопанели 1 контакт последовательного порта 1 контакт микросхемы Clear CMOS
Конструктив	Форм-фактор ATX, 295мм x 210мм Windows 10(64bit)
Поддержка ОС	* Biostar оставляет за собой право добавлять или удалять поддержку любой ОС, с уведомлением или без.

Spanish

Especificaciones	
Compatibilidad con el procesador	Ranura 1151 para el 8º procesador Intel® Core i7 / i5 / i3 / Pentium / Celeron * La familia de procesadores Intel® Core™ de 8ª generación sólo admite la serie 300. *Por favor consultar con www.biostar.com.tw para la lista de compatibilidad con el procesador.
Tipo de Placa	Intel® B360
Memoria	Soporta DDR4 1866/ 2133/ 2400/ 2666 Doble Canal 2x DDR4 DIMM Ranura de memoria Soporta hasta 32 GB Memoria Cada DIMM soporta un modulo non-ECC 4/ 8/ 16 GB DDR4 * Por favor consultar con www.biostar.com.tw para la lista de compatibilidad con el memoria.
Almacenamiento de información	Conector 4x SATA III (6Gb/s) 1x M.2 (M Key) Espacio: Soporta módulo M.2 tipo 2242/ 2260/ 2280 SSD Soporta SATA III (6Gb/s) SSD
LAN	Realtek RTL8111E/RTL8111F/RTL8111HN(Opcional) 10/ 100/ 1000 Mb/s auto negociación, capacidad dúplex Mitad/Completo * El chip de red de la placa base depende de la placa base comprada por el usuario.
Códec Audio	ALC887 Canales Audio de Alta Definición 7.1
USB	Ranura 6x USB 3.1(Gen1) (4 en las entrada/salidas posteriores y 2 por los distribuidores internos) Ranura 6x USB 2.0 (2 en las entrada/salidas posteriores y 4 por los distribuidores internos)
Ranuras de Extinción	Ranura 11x PCIe 3.0 x1 Ranura 1x PCIe 3.0 x16 * El soporte de minería de tarjetas VGA máximo depende del controlador VGA o del software de minería.
Panel trasero de E/S	Ratón 1x PS/2 Teclado 1x PS/2 Ranura 1x VGA Ranura 1x HDMI Ranura 1x LAN Ranura 2x USB 2.0 Ranura 4x USB 3.1(Gen1) Socket audio 3x
Conectores en placa	Conector 4x SATA III Distribuidor 2x USB 2.0 (cada distribuidor soporta 2 ranuras USB 2.0) Distribuidor 1x USB 3.1(Gen1) (cada distribuidor soporta 2 ranuras USB 3.1(Gen1)) Conector con 8 patillas x1 Conector con 24 patillas x2 Conector con 6 patillas x2 (para PCIe) Conector Ventilador procesador x1 Conector Ventilador Sistema x2 Distribuidor Panel Frontal x1 Distribuidor Audio Frontal x1 Distribuidor Ranura Serie x1 Distribuidor CMOS Directo x1
Factor de Forma	Factor de Forma ATX, 295mm x 210mm
Soporte OS	Windows 10(64bit) * Biostar reserva su derecho de añadir o retirar el soporte para cada OS con o sin notificación.

Thai

คุณสมบัติ	
ซีพียู	ซีพียู 1151 สำหรับโปรเซสเซอร์ 8th Intel® Core i7 / i5 / i3 / Pentium / Celeron * ตระกูลโปรเซสเซอร์ Intel® Core™ รุ่นที่ 8 รองรับเฉพาะ 300-Series * เข้าชมได้ที่ www.biostar.com.tw สำหรับรายการซีพียูที่สนับสนุน
ชิพเซ็ต	Intel® B360
หน่วยความจำ	สนับสนุน Dual Channel DDR4 1866/2133/2400/2666 รองรับหน่วยความจำ 2 สล็อต DDR4 DIMM สูงสุดถึง 32 GB ทุก DIMM สนับสนุนโมดูล non-ECC 4/8/16GB DDR4 * เข้าชมได้ที่ www.biostar.com.tw สำหรับรายการหน่วยความจำที่สนับสนุน
กราฟฟิก	รวมกราฟฟิกอยู่ในซีพียู
สต่อระจ	4x SATA III พอร์ตเชื่อมต่อ (6Gb/s) 1x M.2 (M Key) ซีพียู สนับสนุน M.2 ชนิด 2242/ 2260/ 2280 SSD โมดูล สนับสนุน SATA III (6Gb/s) SSD
แลน	Realtek RTL8111E/ RTL8111F/ RTL8111HN(ไม่จำเป็น) 10/ 100/ 1000 Mb/s การเจรจาอัตโนมัติ, ความสามารถในการเพิกซ์ Half / Full * ชิพเครือข่ายเมนบอร์ดขึ้นอยู่กับเมนบอร์ดที่ผู้ใช้ซื้อ
ออดิโอ โคเดก	ALC887 7.1 Channels, High Definition Audio
ยูเอสบี	6x USB 3.1(Gen1) พอร์ต (4 พอร์ตด้านหลัง I/O และ 2 พอร์ต ผ่านพอร์ตเชื่อมต่อด้านใน) 6x USB 2.0 พอร์ต (2 พอร์ตด้านหลัง I/O และ 4 พอร์ต ผ่านพอร์ตเชื่อมต่อด้านใน)
สล็อตขยายเพิ่มเติม	11x PCIe 3.0 x1 สล็อต 1x PCIe 3.0 x16 สล็อต * การสนับสนุนการทำเหมืองข้อมูลการ์ด VGA สูงสุดขึ้นอยู่กับไดรเวอร์ VGA หรือซอฟต์แวร์การทำเหมืองแร่
พอร์ต I/O ด้านหลัง	1x PS/2 เมาส์ 1x PS/2 คีย์บอร์ด 1x VGA พอร์ต 1x HDMI พอร์ต 1x LAN พอร์ต 2x USB 2.0 พอร์ต 4x USB 3.1(Gen1) พอร์ต 3x Audio Jack
พอร์ต I/O ด้านใน	4x SATA III พอร์ตเชื่อมต่อ (6Gb/s) 2x USB 2.0 พอร์ตเชื่อมต่อ (หัวเชื่อมต่อทุกตัวรองรับ 2 พอร์ต USB 2.0) 1x USB 3.1(Gen1) พอร์ตเชื่อมต่อ (หัวเชื่อมต่อทุกตัวรองรับ 2 พอร์ต USB 3.1(Gen1)) 1x 8-Pin Power พอร์ตเชื่อมต่อ 2x 24-Pin Power พอร์ตเชื่อมต่อ 2x 6-Pin PCIe Power พอร์ตเชื่อมต่อ 1x พอร์ตเชื่อมต่อ CPU Fan 2x พอร์ตเชื่อมต่อระบบ Fan 1x พอร์ตเชื่อมต่อแผงด้านหน้า 1x พอร์ตเชื่อมต่อออดิโอด้านหน้า 1x พอร์ตเชื่อมต่อ Serial Port 1x พอร์ต Clear CMOS
รูปแบบจากโรงงาน	ขนาด ATX จากโรงงาน, 210 มม. x 295 มม.
สนับสนุน OS	Windows 10(64bit) * Biostar ขอสงวนสิทธิ์ในการเพิ่มหรือลดการสนับสนุนสำหรับระบบปฏิบัติการ OS ต่างๆ โดยไม่ต้องแจ้งให้ทราบล่วงหน้า

this page intentionally left blank



FCC条款

依照FCC条款第15部分的规定，本装置已经通过测试并且符合Class B级数字装置的限制。此条款限制了在安装过程中可能造成的有害射频干扰并提供了合理的防范措施。本装置在使用时会产生无线射频辐射，如果没有依照本手册的指示安装和使用，可能会与无线通讯装置产生干扰。然而，并不保证在特定的安装下不会发生任何干扰。

如果关闭和重新开启本设备后，仍确定本装置造成接收广播或电视的干扰，用户可以使用以下列表中的一种或多种方法来减少干扰：

- 重新安装或调整接收天线。
- 增加本设备与接收设备之间的距离。
- 连接设备连接到不同的插座以便于两个设备使用不同的回路。
- 咨询经销商或富有经验的无线电工程师，以获得更多资讯。

本用户手册内容的变更，恕不另行通知，制造商没有解释的义务。

本用户手册的所有内容若有任何错误，制造商没有义务为其承担任何责任。所有商标和产品名称均有其各自所有权。

未经过书面许可，不得以任何形式（部分或全部）复制此手册信息。

免责声明

本手册内容系BIOSTAR®知识产权，版权归BIOSTAR®所有。我们本着对用户负责的态度，精心地编写该手册，但不保证本手册的内容完全准确无误。BIOSTAR®有权在不知会用户的前提下对产品不断地进行改良、升级及对手册内容进行修正，实际状况请以产品实物为准。本手册为纯技术文档，无任何暗示及影射第三方之内容，且不承担排版错误导致的用户理解歧义。本手册中所涉及的第三方注册商标所有权归其制造商或品牌所有人。



CE符合性简短声明

我们声明此产品符合现行标准，并满足2004/108/CE、2006/95/CE 和1999/05/CE指令规定的所有基本要求。

防静电操作规则

静电可能严重损坏您的设备，在处理主板以及其它的系统设备的时候要特别注意，避免和主板上的系统组件的不必要接触，保证在抗静电的环境下工作，避免静电放电可能对主板造成损坏，当在您的机箱中插入或者移除设备时，请保证电源处于断开状态，厂商对于不遵照本操作规则或者不遵守安全规范而对主板造成的损坏不负责。



警告
主板易受静电损坏
请遵守操作规则



目录

第一章: 主板介绍	3
1.1 前言	3
1.2 包装清单	3
1.3 主板特性	4
1.4 后置面板接口	5
1.5 主板布局图	6
第二章: 硬件安装	7
2.1 中央处理器(CPU)	7
2.2 散热片	9
2.3 风扇接头	10
2.4 系统内存	10
2.5 扩展槽	12
2.6 跳线设置	13
2.7 接口和插槽	14
第三章: UEFI BIOS和软件	18
3.1 UEFI BIOS设置	18
3.2 刷新BIOS	18
3.3 软件	22
第四章: 帮助信息	23
4.1 驱动程序安装注意事项	23
4.2 AMI BIOS 哔声代码	24
4.3 AMI BIOS 开机自检代码	24
4.4 问题解答	26
附录I : 产品中有毒有害物质或元素的名称及含量	27

第一章: 主板介绍

1.1 前言

感谢您选购我们的产品，在开始安装主板前，请仔细阅读以下安全指导说明：

- 选择清洁稳定的工作环境。
- 操作前请确保计算机断开电源。
- 从防静电袋取出主板之前，先轻触安全触地器或使用触地手腕带去除静电以确保安全。
- 避免触摸主板上的零件。手持电路板的边缘，不要弯曲或按压电路板。
- 安装之后，确认没有任何小零件置于机箱中，一些小的零件可能引起电流短路并可能损坏设备。
- 确保计算机远离危险区域，如：高温、潮湿、靠近水源的地方。
- 计算机的工作温度应保持在0-45°C之间
- 为避免受伤，请注意以下幾點：
主板或連接器上尖銳的針腳
机箱上的粗糙边缘和尖角
破损的线缆可能引起短路

1.2 包装清单

- Serial ATA数据线 x2
- ATX机箱后置I/O面板 x1
- 用户手册 x1
- 驱动光盘 x1 (包括安装驱动)

注意

» 此清单可能因销售区域或主板型号不同而异，相关标配详情请咨询当地经销商。

1.3 主板特性

规格	
CPU支援	Socket 1151 · 第8代Intel® Core i7 / i5 / i3 / Pentium / Celeron处理器 * 第8代Intel® Core™ 处理器系列仅支持300系列 * 请访问 www.biostar.com.tw 获取CPU的支持列表
芯片组	Intel® B360
内存	支持双通道DDR4 1866/ 2133/ 2400/ 2666 2个DDR4 DIMM插槽 · 最大内存容量为32GB 每个DIMM支持非ECC 4/ 8/ 16 GB DDR4内存模组 * 请访问 www.biostar.com.tw 获取内存的支持列表
存储器	4个 SATA III 接口 (6Gb/s) 1个M.2 (M Key)插槽: 支持 M.2 Type 2242/ 2260/ 2280 SSD模块 支持 SATA III (6.0Gb/s) SSD
网络	Realtek RTL8111E/RTL8111F/RTL8111HN(选配) 10/ 100/ 1000 Mb/s自适应传输模式 · 半双工/全双工工作模式 * 主板网络芯片取决于用户购买的主板。
音效	ALC887 7.1声道音频输出 · 支持高清音频
USB	6个USB 3.1(Gen1)端口(背板4个端口 · 板载接头支持2个端口) 6个USB 2.0端口 (背板2个端口 · 板载接头支持4个端口)
扩展槽	11个PCIe 3.0 x1插槽 1个PCIe 3.0 x16插槽 * 最大的VGA卡采矿数量支持取决于VGA驱动程序或采矿软件。
背板接口	1个PS/2鼠标接口 1个PS/2键盘接口 1个VGA端口 1个HDMI端口 1个LAN端口 2个USB2.0端口 4个USB3.1(Gen1)端口 3个音频插孔
板载接口	4个SATA III接口 (6Gb/s) 2个USB2.0接头(每个接头支持2个USB2.0端口) 1个USB3.1(Gen1)接头(每个接头支持2个USB3.1(Gen1)端口) 1个电源接口(8针) 1个电源接口(24针) 2个PCIe电源接口(6针) 1个CPU风扇接头 2个系统风扇接头 1个前置面板接头 1个前置音频接头 1个串行端口接头 1个清空CMOS数据接头
主板尺寸	ATX Form Factor, 295 mm x 210 mm
操作系统支持	Windows 10(64bit) * 如有增加或减少任何OS支持 · Biostar保留不预先通知的权利。

1.4 后置面板接口

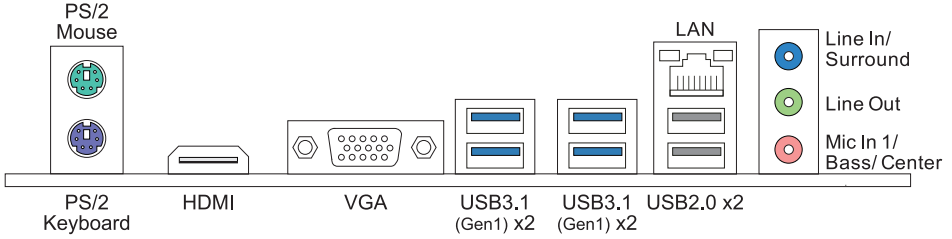

注意

- » 仅Intel集成显卡处理器支持VGA/HDMI端口。
- » 最高分辨率：
VGA: 1920 x 1200 @60Hz
HDMI: 4096 x 2160 @24Hz·符合HDMI 1.4规范
- » 当使用前置HD音频插孔并插入耳机/麦克风时，后置声音将自动禁用。
- » 如需配置7.1声道，需要使用到一个HD前置音源输出模组，并且在系统音频工具中设置多声道功能。
- » 主板同时支持2个板载显示端口输出。显示输出的配置可以在英特尔图形驱动程序工具中进行选择。

2/ 4/ 5.1/ 7.1-声道模式配置

音频接口	2 声道模式	4 声道模式	5.1 声道模式	7.1 声道模式
蓝色 (背部面板)	线性输入	线性输入	线性输入	侧边声道输出
绿色 (背部面板)	线性输出	前置声道输出	前置声道输出	前置声道输出
粉红色 (背部面板)	麦克风输入	麦克风输入	中置/重低音声道输出	中置/重低音声道输出
草绿色 (前置面板)	耳机	后置声道输出	后置声道输出	后置声道输出

1.5 主板布局图

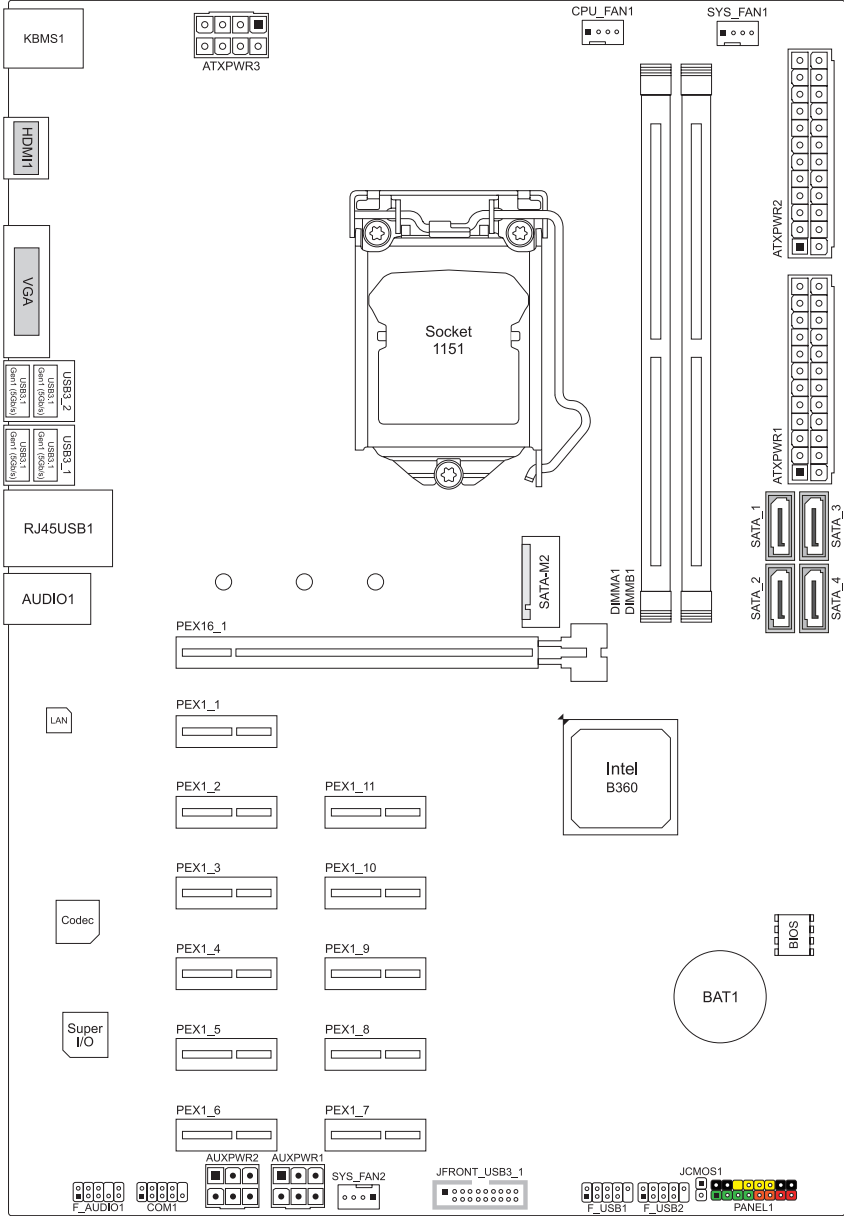

注意

» ■ 标示为针脚1

第二章: 硬件安装

2.1 中央处理器(CPU)

步骤1: 找到主板上的CPU插槽。

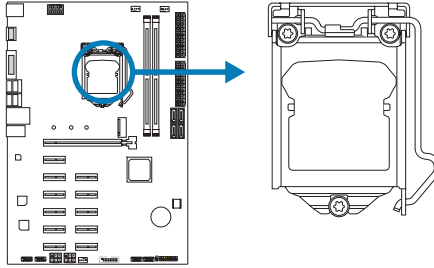

注意

- » 安装前请取掉针脚保护盖，并妥善保管以备后用。移开CPU后，请盖上保护盖以确保针脚不被损坏。
- » 主板可能配有两种不同的针脚保护盖，请参照以下指示取掉保护盖。

步骤2: 将拉杆从插槽移出并向上抬起

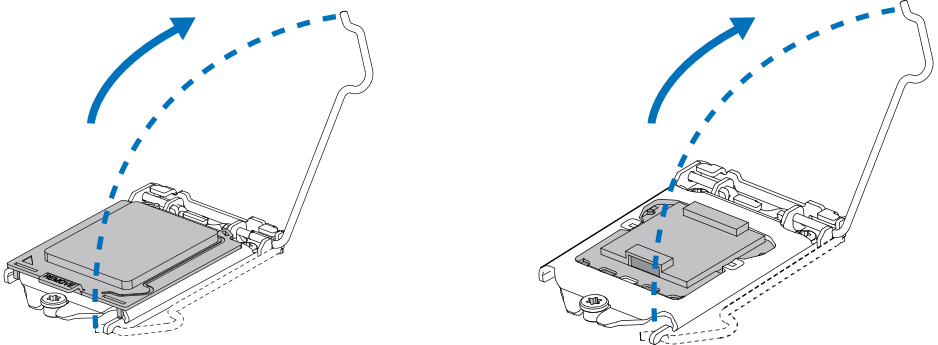

步骤3: 取掉针脚保护盖

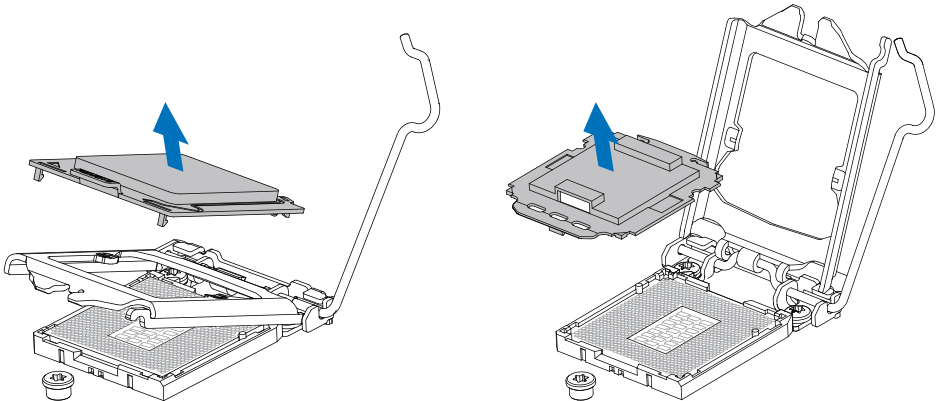

步骤4: 按照箭头的指示方向，将CPU上的切口对准插槽上相应的位置，然后将CPU放入插槽处

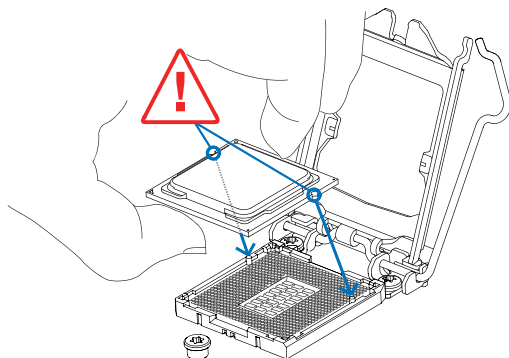

步骤5: 固定CPU，将拉杆闭合。

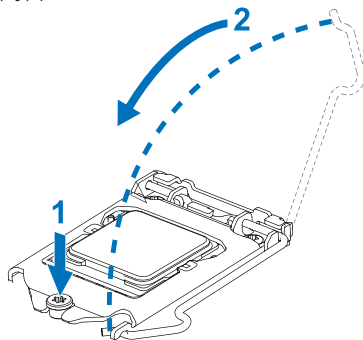

注意

- » 请确保安装专为LGA1151插座设计的CPU。
- » CPU必须按正确的方向放入，不要强行将CPU放进插槽以免损坏CPU。

2.2 散热片

步骤1: 请将CPU风扇组件置于CPU顶部，确保四个钉钩对齐主板上的插孔，调整其方位，使风扇电线与CPU风扇接口间距最近。确保钉钩插槽垂直指向散热片。

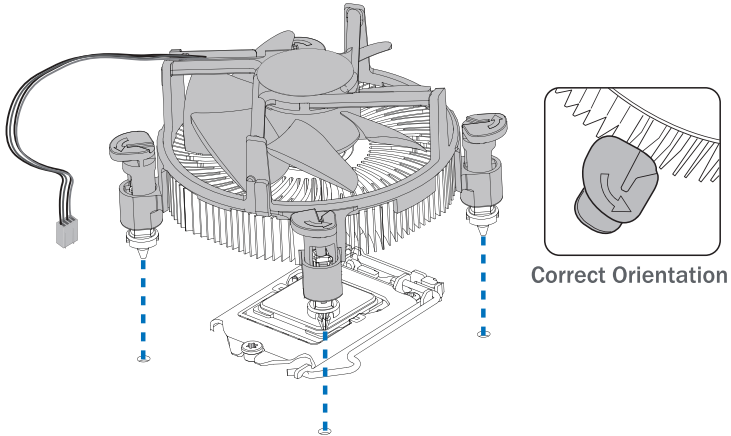

步骤2: 依次把对角2个钉钩同时向下按，以固定风扇，完成CPU安装。

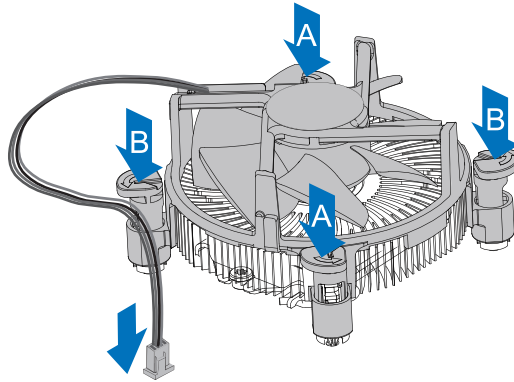

注意

- » 如有必要，在安装散热风扇前请先涂抹散热膏于CPU表面。
- » 请务必连接CPU风扇接口。
- » 请参照CPU散热片的安装手册获取正确的安装信息。

2.3 风扇接头

此风扇接头支持电脑内置的冷却风扇，风扇引线和插头可能因制造商而异。

CPU_FAN1: CPU 风扇接头

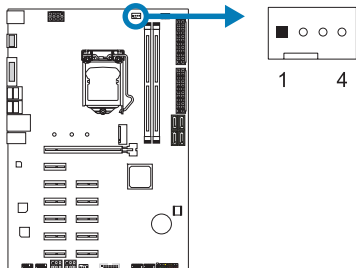

Pin	Assignment
1	接地
2	+12V
3	FAN RPM rate sense
4	Smart Fan Control (By Fan)

SYS_FAN1/ SYS_FAN2: 系统风扇接头

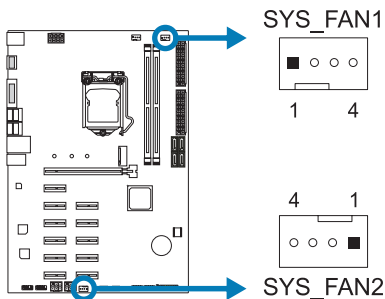

Pin	Assignment
1	接地
2	+12V
3	FAN RPM rate sense
4	Smart Fan Control (By Fan)

注意

» CPU_FAN1·SYS_FAN1·SYS_FAN2支持4针脚和3针脚接口；接线时请注意红线是正极需接到第二个针脚，黑线接地需接到GND针脚。

2.4 系统内存

DDR4内存模组

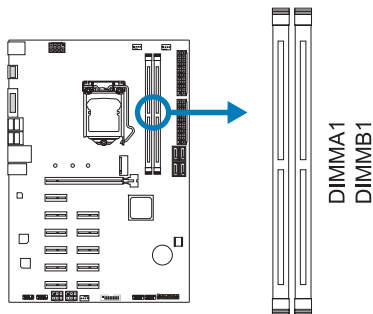

步骤1: 向外推开固定夹，打开DIMM插槽。将DIMM按顺序放在插槽上，DIMM上的切口须与插槽凹口匹配。

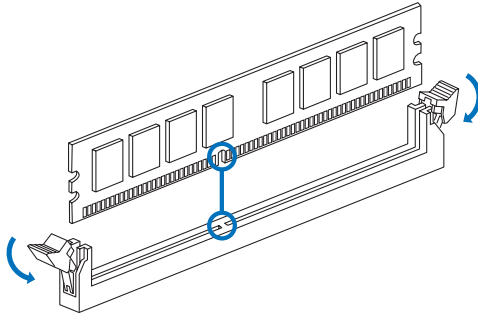

步骤2: 垂直插入DIMM并固定好，直到固定夹跳回原位，DIMM就位。

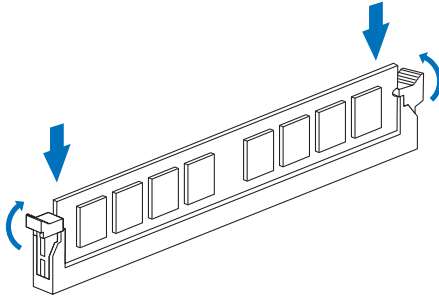

注意

» 如果DIMM未顺利插入，请勿强行按压。将DIMM拔出，再重插一次。

内存容量

DIMM插槽位置	DDR4模组	最大内存容量
DIMMA1	4GB/8GB/16GB	32GB
DIMMB1	4GB/8GB/16GB	

双通道内存安装

为激活主板双通道功能，使用内存模组必须符合以下要求：成对安装相同密度的内存模组。如下表所示

双通道状态	DIMMA1	DIMMB1
Disabled	○	X
Disabled	X	○
Enabled	○	○

(“○”表示内存已安装，“X”表示内存未安装。)

注意

» 当安装多个内存模块时，我们建议使用相同品牌和容量的内存安装于主板上。

2.5 扩展槽

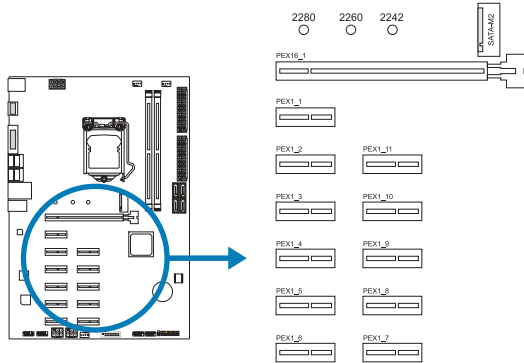

PEX16_1: PCI-Express Gen3 x16 插槽

- 符合PCI-Express 3.0规范。
- 同步单向最大理论带宽为16GB/s·总带宽为32GB/s。

PEX1_1/ PEX1_2/ PEX1_3/ PEX1_4/ PEX1_5/ PEX1_6/ PEX1_7/ PEX1_8/ PEX1_9/ PEX1_10/ PEX1_11: PCI-Express Gen3 x1 插槽

- 符合PCI-Express 3.0规范。
- 同步单向最大理论带宽为1GB/s·总带宽为2GB/s。

SATA-M2: M.2 (M Key) 插槽

- M.2插槽支持M.2 Type 2242/2260/2280 SSD模块。安装M.2模块前请将六角柱放到正确的位置。
- 支持M.2 SATA III (6.0 Gb/s)模块。

注意

» 最大的VGA卡采矿数量支持取决于VGA驱动程序或采矿软件。

安装扩展卡

请参照以下步骤安装扩展卡：

- 安装扩展卡前请阅读扩展卡的相关指示说明。
- 打开电脑机箱后盖，移除螺丝和插槽支架。
- 将扩展卡按照正确的方向插入插槽，直到扩展卡完全就位。
- 用螺丝将扩展卡的金属支架固定到机箱后置面板。
- 还原电脑机箱后盖。
- 开机。如有必要，可为扩展卡更改BIOS设置。
- 安装扩展卡的驱动。

2.6 跳线设置

下图展示如何设置跳线。当跳帽放置在针脚上时，跳线为闭合(close)状态。否则跳线为断开(open)状态。

Pin 打开



Pin 闭合



Pin 1-2 闭合



JCMOS1: 清空CMOS 跳线

用户可清空CMOS数据并恢复BIOS安全设置，请按照以下步骤操作以免损坏主板。

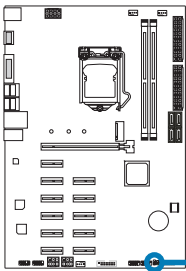

Pin 1-2 打开: 正常操作(默认)



Pin 1-2 闭合: 清空CMOS数据

清空CMOS数据过程:

1. 断开AC电源。
2. 将跳线设置成1-2接脚闭合，建议可以使用一个金属物体如螺丝刀触碰1-2接脚。
3. 等待5秒钟。
4. 清空CMOS数据後，请确认跳线设置成1-2接脚打开。
5. 接通AC电源。
6. 开机然后按下键进入BIOS设置。

2.7 接口和插槽

ATXPWR1/ ATXPWR2: ATX电源接口

为了更好的兼容性，我们建议使用标准的ATX24-pin电源供应此接口的电源。

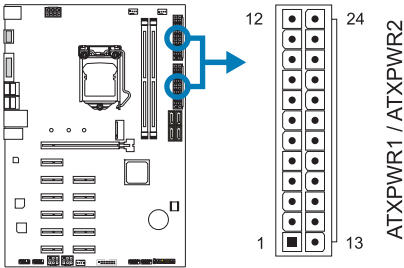

针	定义	针	定义
13	+3.3V	1	+3.3V
14	-12V	2	+3.3V
15	接地	3	接地
16	PS_ON	4	+5V
17	接地	5	接地
18	接地	6	+5V
19	接地	7	接地
20	NC	8	PW_OK
21	+5V	9	唤醒电压+5V
22	+5V	10	+12V
23	+5V	11	+12V
24	接地	12	+3.3V

ATXPWR3: ATX电源接口

此接口给CPU电路提供+12V电压。若CPU电源插头为4针脚，请将其插入ATXPWR3的1-2-5-6针脚。

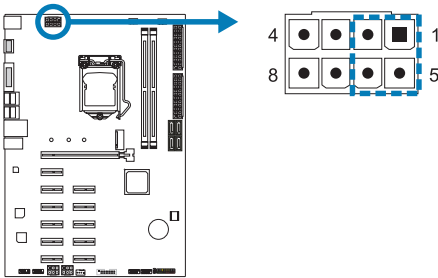

针	定义
1	+12V
2	+12V
3	+12V
4	+12V
5	接地
6	接地
7	接地
8	接地

注意

- » 开机前，请确保ATXPWR1/ ATXPWR2和ATXPWR3接口都已插上电源。
- » 当只有一个电源时，24针ATX电源连接器必须连接到ATXPWR1，否则将无法启动。
- » 当有两个电源时，请先安装第一个电源，并将24针ATX电源连接器连接到ATXPWR1，将8针ATX电源连接器连接到ATXPWR3。之后再安装第二个电源，将24针ATX电源连接器连接到ATXPWR2。如果安装不正确，将会造成主板损坏。
- » 电压不足可能导致系统不稳或者外围设备不能正常运行。当配置使用大功率设备的系统时，建议您使用带有大功率输出的电源。

安装两个电源规则

请参照以下步骤安装两个电源：

1. 电源1的24针ATX电源连接器连接到ATXPWR1。
2. 电源1的8针或4针ATX电源连接器连接到ATXPWR3。
3. 电源2的24针ATX电源连接器连接到ATXPWR2。

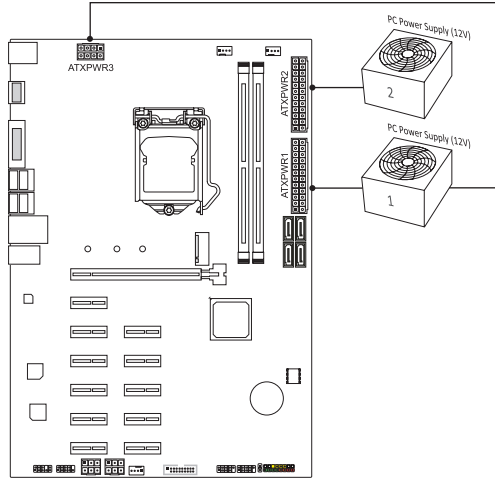

注意

» 确保适当的引脚连接到ATX电源连接器·错误的连接可能会损坏您的主板。

AUXPWR1/ AUXPWR2: PCIe电源接口

此接口给PCIe电路提供+12V电压。

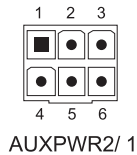
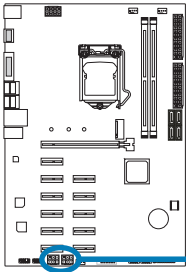

针	定义
1	+12V_Output
2	+12V_Output
3	+12V_Output
4	接地
5	接地
6	接地

PANEL1: 前置面板接头

此16针脚接口包含开机·重启·硬盘指示灯·电源指示灯和扬声器接口。

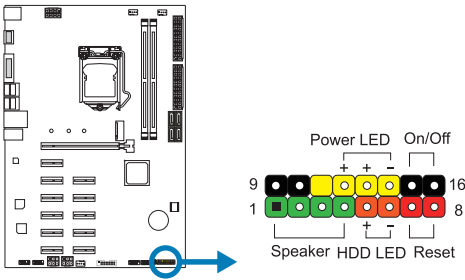

针	定义	功能	针	定义	功能
1	+5V	扬声器接口	9	N/A	电源指示灯
2	N/A		10	N/A	
3	N/A		11	N/A	
4	扬声器	硬盘指示灯	12	Power LED (+)	电源指示灯
5	HDD LED (+)		13	Power LED (+)	
6	HDD LED (-)	重启按钮	14	Power LED (-)	开机按钮
7	接地		15	电源按钮	
8	Reset control	16	接地		

SATA_1/ SATA_2/ SATA_3/ SATA_4: 串行ATA接口

此接口通过SATA数据线连接SATA硬盘。

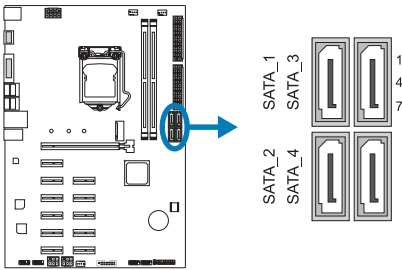

针	定义
1	接地
2	TX+
3	TX-
4	接地
5	RX-
6	RX+
7	接地

JFRONT_USB3_1: 前置面板USB 3.1(Gen1)接头

PC前置面板支持附加的USB数据线·也可连接即插即用外围设备。

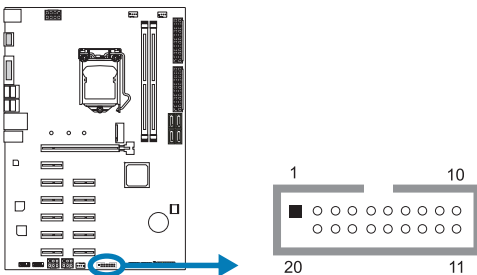

针	定义	针	定义
1	VBUS0	11	D2+
2	SSRX1-	12	D2-
3	SSRX1+	13	接地
4	接地	14	SSTX2+
5	SSTX1-	15	SSTX2-
6	SSTX1+	16	接地
7	接地	17	SSRX2+
8	D1-	18	SSRX2-
9	D1+	19	VBUS1
10	ID	20	Key

F_USB1/ F_USB2: 前置面板USB 2.0接头

PC前置面板支持附加的USB数据线，也可连接即插即用外围设备。

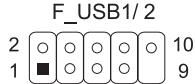
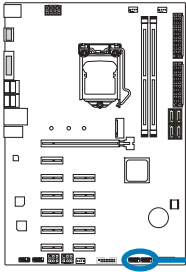

针	定义
1	+5V (fused)
2	+5V (fused)
3	USB-
4	USB-
5	USB+
6	USB+
7	接地
8	接地
9	Key
10	NC

F_AUDIO1: 前置面板音频接头

此接头可连接音频输出数据线，支持HD(高清)音频和AC' 97。

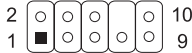
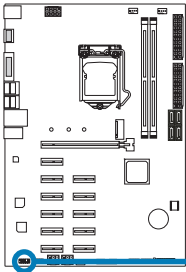

HD Audio		AC' 97	
针	定义	针	定义
1	Mic Left in	1	Mic In
2	接地	2	接地
3	Mic Right in	3	Mic Power
4	GPIO	4	Audio Power
5	Right line in	5	RT Line Out
6	Jack Sense	6	RT Line Out
7	Front Sense	7	Reserved
8	Key	8	Key
9	Left line in	9	LFT Line Out
10	Jack Sense	10	LFT Line Out

注意

- » 建议您连接前置高清音频插孔，享用主板高清音频功能。
- » 如果要连接AC' 97前置音频输出数据线，请关闭“前置面板插孔检测功能”。此功能在系统音频工具中可见。

COM1: 串行端口

此主板有一串行端口，可连接至RS-232端口。

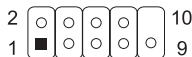
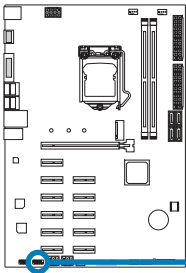

针	定义
1	Carrier detect
2	Received data
3	Transmitted data
4	Data terminal ready
5	Signal ground
6	Data set ready
7	Request to send
8	Clear to send
9	Ring indicator
10	Key

第三章: UEFI BIOS和软件

3.1 UEFI BIOS设置

- BIOS设置程序可用于查看和更改计算机的BIOS设置。开机自检时，按键可进入BIOS设置程序。
- 更多相关UEFI BIOS设置信息，请参考网站上的UEFI BIOS手册。

3.2 刷新BIOS

以下任意一种工具都可以刷新BIOS:

- BIOSTAR BIOS Flasher: 使用此工具，BIOS可通过硬盘上的文件刷新，USB驱动刷新，或者CD-ROM刷新。
- BIOSTAR BIOS刷新工具: 能够在Windows环境下自动刷新。使用此工具，BIOS可通过硬盘上的文件刷新，USB驱动刷新，CD-ROM刷新或者从网站上的文件地址刷新。

BIOSTAR BIOS Flasher

注意

- » 此工具仅允许可使用FAT32/16格式化或单个分区的存储设备。
- » 刷新BIOS时如关机或重启系统将导致系统引导失败。

使用BIOSTAR BIOS Flasher刷新BIOS

1. 进入网站下载与主板相匹配的最新BIOS文件。
2. 然后保存BIOS文件到U-盘。(仅支持FAT/FAT32格式)
3. 插入包含BIOS文件的U-盘到USB接口
4. 开机或重启后，在自检过程中按<F12>键。

5. 进入自检后，屏幕会弹出BIOS-FLASHER工具。选择<fs0>搜索BIOS文件。

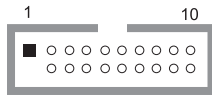
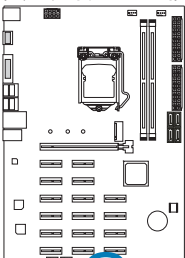

6. 选择合适的BIOS文件，并按“ Yes” 执行BIOS刷新程序。



7. BIOS刷新后会弹出是否重启系统的对话框。按<Y>重启系统

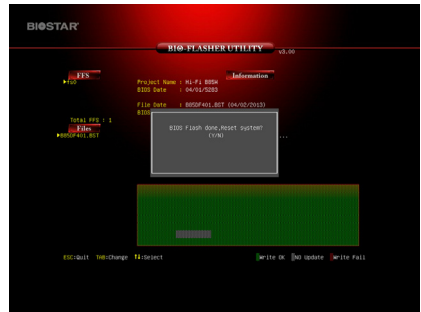

8. 系统引导并出现相关标识信息时，按键进入BIOS设置。选择<Save & Exit>，使用<Restore Defaults>功能加载系统默认值，然后选择<Save Changes and Reset>来重启系统，完成BIOS刷新。

BIOS刷新工具（通过网络）

1. 用DVD驱动安装BIOS Update Utility。
2. 使用此功能时，请确保电脑联网。

3. 打开BIOS刷新工具，然后点击“Online Update”按钮。



4. 屏幕弹出是否执行刷新BIOS程序的对话框，点击“ Yes”开始刷新BIOS。

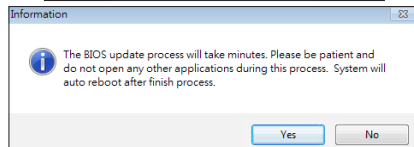

5. 如果BIOS有新版本，屏幕会弹出提示您下载最新版本的对话框。点击“ Yes”下载。

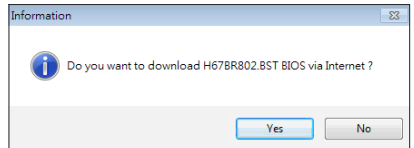

6. 完成下载后，屏幕弹出提示您刷新BIOS的对话框，点击“ Yes”开始刷新。

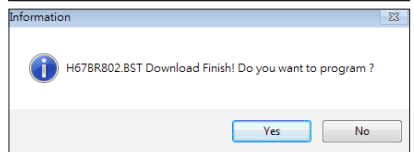

7. 刷新程序结束后，屏幕弹出提示您重启系统的对话框。点击“OK”重启系统。

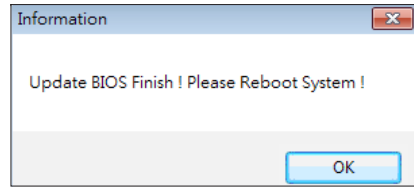

8. 系统引导并出现相关标识信息时，按键进入BIOS设置。选择<Save & Exit>，使用<Restore Defaults>功能加载系统默认值，然后选择<Save Changes and Reset>来重启系统，完成BIOS刷新。

BIOS刷新工具（通过BIOS文件）

1. 用DVD驱动安装BIOS刷新工具。
2. 从我们的网站www.biostar.com.tw 下载合适的BIOS。

3. 在主页面打开BIOS Updat Utility，然后点击“Update BIOS”按钮。



4. 屏幕弹出是否执行刷新BIOS程序的对话框，点击“OK”开始刷新BIOS。

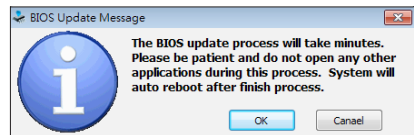

5. 选择BIOS文件的存放目录。然后选择合适的BIOS文件，点击“Open”。刷新BIOS要花几分钟时间，请耐心等待。

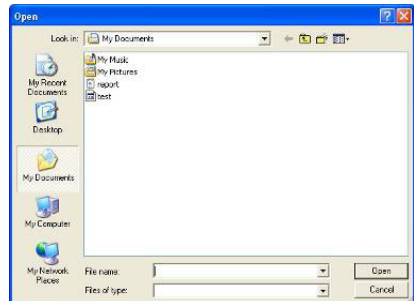

6. BIOS刷新过程结束后，点击“OK”重启系统。

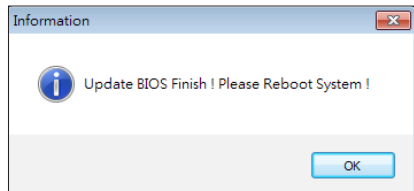

7. 系统引导并出现相关标识信息时，按键进入BIOS设置。
选择<Save & Exit>，使用<Restore Defaults>功能加载系统默认值，然后选择<Save Changes and Reset>来重启系统，完成BIOS刷新。

BIOS备份

点击BIOS备份按钮，选择存储备份文件的合适目录，然后点击“ Save”。

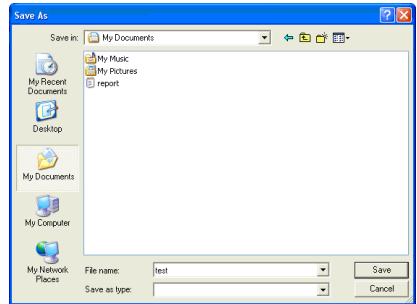

3.3 软件

安装软件

1. 将光盘放入光驱，若Autorun功能已激活，驱动安装程序将会出现。
2. 选择Software Installation，然后点击各软件图标。
3. 根据屏幕上的指令完成安装。

启动软件

安装程序完成后，桌面上将出现软件图标。请双击图标启动软件工具。

注意

- » 所有软件的相关信息和内容若有变更，恕不另行通知。为使系统性能更佳，软件会不断升级。
- » 下面的图片和信息仅供参考，此主板的实际信息和设置可能与手册稍有差异。

BIOScreen 工具

此实用工具可以将开机画面个性化。您可以选择BMP格式来自定义计算机开机画面。



请参照以下步骤来更新开机画面：

- 加载画面(Load Image)：选择图片作为开机画面。
- 转换(Transform)：转换图片并预览。
- 更新BIOS(Update Bios)：将图片写入BIOS内存，然后完成更新。

第四章:帮助信息

4.1 驱动程序安装注意事项

为获得更好的系统性能，在操作系统安装完成后，请插入您的系统驱动到光驱并安装。插入DVD后，将出现如下所示窗口。



此设置向导将自动检测您的主板和操作系统。

A. 驱动程序安装

安装驱动程序，请点击驱动器图标。设置向导将列出主板兼容驱动和操作系统。点击各设备驱动程序，以开始安装进程。

B. 软件安装

安装软件，请点击软件图标。设置向导将列出系统可用软件，点击各软件名称，以开始安装进程。

C. 使用手册

除了书本形式的手册，我们也提供光盘形式的使用指南。点击Manual图标，浏览可用相关使用指南。

注意

- » 在插入驱动之后，如此窗口未出现，请用文件浏览器查找并执行SETUP.EXE文件。
- » 若需要Acrobat Reader打开manual文件，请从网站<http://get.adobe.com/reader/>下载最新版本的Acrobat Reader软件。

4.2 AMI BIOS 哔声代码

引导模块哔声代码

哔声次数	含义
持续哔声	持续哔声

BIOS 开机自检哔声代码

哔声次数	含义
1	系统引导成功
8	显存错误(系统视频适配器)

4.3 AMI BIOS 开机自检代码

代码	含义
10	PEI核心启动
11	CPU Pre-memory初始化启动
15	北桥Pre-memory初始化启动
19	南桥Pre-memory初始化启动
2B	内存初始化·读取SPD数据
2C	内存初始化·检测Memory presence
2D	内存初始化·编程内存时序信息
2E	内存初始化·配置内存
2F	内存初始化(其他)
31	内存安装完成
32	CPU post-memory初始化启动
33	CPU post-memory初始化·Cache初始化
34	CPU post-memory初始化·应用处理器初始化
35	CPU post-memory初始化·选择BSP
36	CPU post-memory初始化·系统管理模式初始化
37	北桥Post-Memory初始化启动
3B	北桥Post-Memory初始化
4F	DXE IPL启动
60	DXE核心启动
F0	固件引起的恢复条件(自动恢复)
F1	用户引起的恢复条件(强制恢复)
F2	恢复进程启动
F3	找到固件恢复图象
F4	加载固件恢复图象
E0	S3唤醒启动
E1	执行S3启动脚本
E2	重新发送影像
E3	系统S3待机导向
60	DXE内核启动
61	NVRAM初始化
62	安装南桥运行期
63	CPU DXE初始化启动
68	PCI HB初始化
69	北桥DXE初始化
6A	北桥DXE SMM初始化启动

代码	含义
70	南桥DXE初始化启动
71	南桥DXE SMM初始化启动
72	南桥设备初始化
78	南桥DXE初始化
79	ACPI模组初始化
90	引导设备选择阶段启动
91	驱动连接启动
92	PCI总线初始化启动
93	PCI总线热拔插控制器初始化
94	PCI总线列举
95	PCI总线请求资源
96	PCI总线分配资源
97	控制台输出设备连接
98	控制台输入设备连接
99	高级IO初始化
9A	USB初始化启动
9B	USB复位
9C	USB检测
9D	USB启用
A0	IDE初始化启动
A1	IDE复位
A2	IDE检测
A3	IDE启用
A4	SCSI初始化启动
A5	SCSI复位
A6	SCSI检测
A7	SCSI启用
A8	设置校对密码
A9	设置开始
AB	设置输入等待
AD	准备启动环境
AE	传统启动环境
AF	退出启动环境
B0	虚拟地址图开始
B1	虚拟地址图结束
B2	传统可选ROM初始化
B3	系统复位
B4	USB热拔插
B5	PCI总线热拔插
B6	清理NVRAM
B7	配置复位(NVRAM设置复位)

注意

» 如此窗若出现表格未列出的代码，请联系我们的技术支持。

4.4 问题解答

问题	解决方法
1. 系统没有电，电源指示灯不亮，电源风扇不转动。 2. 键盘上的指示灯不亮。	1. 确定电源线是否接好。 2. 更换线材。 3. 联系技术支持。
系统不起作用。键盘指示灯亮，电源指示灯亮，硬盘正常运作。	用力按压内存两端，确保内存安置于插槽中。
系统不能从硬盘启动，能从光盘启动。	1. 检查硬盘与主板的连线，确定各连线是否确实接好，检查标准CMOS设置中的驱动类型。 2. 硬盘随时都有可能坏掉，所以备份硬盘数据是很重要的。
系统只能从光盘启动。硬盘能被读，应用程序能被使用，但是不能从硬盘启动。	1. 备份数据和应用程序。 2. 重新格式化硬盘。用后备盘重新安装应用程序和数据。
屏幕提示“Invalid Configuration”或“CMOS Failure”。 再次检查系统设备，确定设定是否正确安装了第二个硬盘	再次检查系统设备，确定设定是否正确
安装了第二个硬盘后，系统不能启动。	1. 正确设置主/从硬盘跳线。 2. 运行安装程序，选择正确的驱动类型。与驱动器厂商联系，寻求驱动兼容性的技术支持。

CPU过热保护系统

在开启系统数秒后如有自动关机的现象，这说明CPU保护功能已被激活。CPU过热时，防止损坏CPU，主机将自动关机，系统则无法重启。

此种情况下，请仔细检查。

1. CPU 散热器平放在CPU表面。
2. CPU风扇能正常旋转。
3. CPU风扇旋转速度与CPU运行速度相符。

确认后，请按以下步骤缓解CPU保护功能。

1. 切断电源数秒。
2. 等待几秒钟。
3. 插上电源开启系统。

或是：

1. 清除CMOS数据。(查看“Close CMOS Header: JCMOS1”部分)
2. 等待几秒钟。
3. 重启系统。

附录I：产品中有毒有害物质或元素的名称及含量

部件名称	有毒有害物质或元素					
	铅 (Pb)	汞 (Hg)	镉 (Cd)	六价铬 (Cr(VI))	多溴联苯 (PBB)	多溴二苯醚 (PBDE)
PCB板	○	○	○	○	○	○
结构件	○	○	○	○	○	○
芯片及其它主动零件	X	○	○	○	○	○
连接器	X	○	○	○	○	○
被动电子元器件	X	○	○	○	○	○
焊接金属	○	○	○	○	○	○
线材	○	○	○	○	○	○
助焊剂·散热膏·标签及其它耗材	○	○	○	○	○	○

○：表示该有毒有害物质在该部件所有均质材料中的含量在SJ/T11363-2006标准规定的限量要求以下。

X：表示该有毒有害物质至少在该部件的某一均质材料中的含量超出SJ/T11363-2006标准规定的限量要求。

备注：在芯片及其它主动零件、连接器、被动电子元器件Pb栏位中有打X，表示Pb在该部件的某一均质材料中的含量超出SJ/T11363-2006标准规定的限量要求，但均符合欧盟ROHS指令豁免条款。